

Actuator/control for shutter

MX5220 - MX5220C - Y4672M2S

Description

Flush mounted two-module shutter actuator/control with 2 internal 2A 250 VA relays. In addition to the monostable and bistable functionality, it allows the management of the specific shutter position (preset). The device can also be configured to manage a remote actuator.

To be completed with 1 or 2-module covers.

In case of management of groups of lights, this device support the return state (please check the production date starting from 26W17).

Technical data

Operating temperature: 0 – 40 °C
 Voltage: 110 – 230 Vac
 Operating frequency: 50/60 Hz
 Cable section: 2 x 1,5 m² or 1 x 2,5 m²
 Power supply from SCS Bus: 18 – 27 Vdc
 Absorption (max. LED intensity): 9 mA (stand-by)
 17 mA max (max one load)
 26 mA (max two loads)

Loads	Reducer motors for shutters	
230 Vac	460 W	2 A
110 Vac	250 W	2 A

Dimensional data

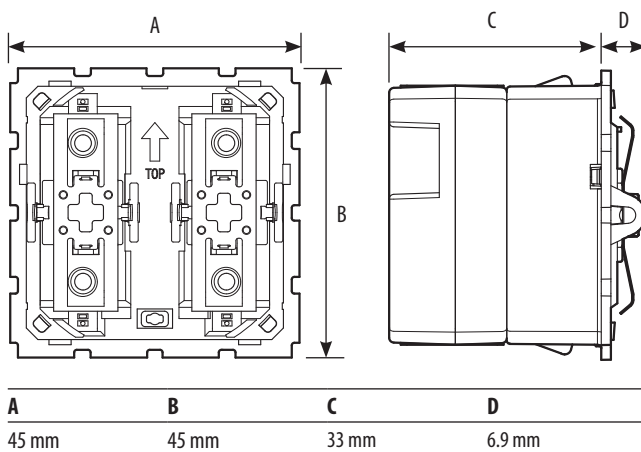

Control module

Front view

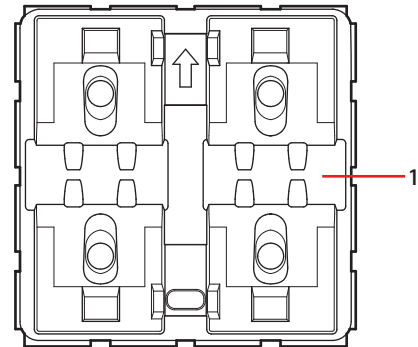

Front view without protective shell

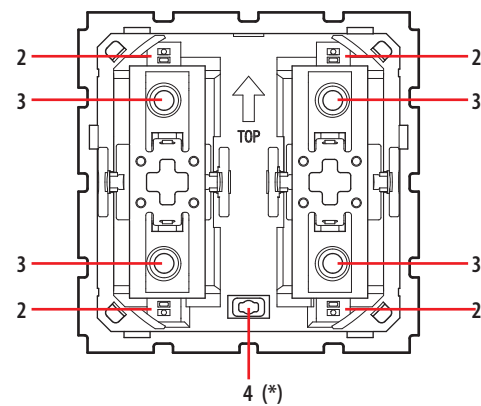

Legend

1. Protective shell
2. Status notification LED:
Y4672M2S:
 Blue steady = load ON
 White steady = load OFF
 Blue flashing = object not configured
MX5220/MX5220C:
 Purple steady = load ON
 Blue steady = load OFF
 Purple flashing = object not configured
3. Control pushbutton
4. LED pushbutton (*)

(*) With the device configured, by pressing the LED button it is possible to set whether the LEDs should always be on (maximum level, medium level or minimum level) or off. Starting from MEDIUM LEVEL, when the pushbutton is kept pressed, every 2 seconds the LED lights will switch from MINIMUM, to OFF, to MAXIMUM, to MEDIUM level.

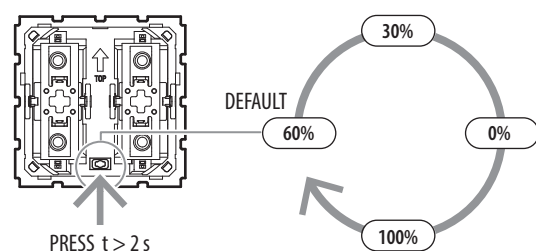

Control module

Rear view

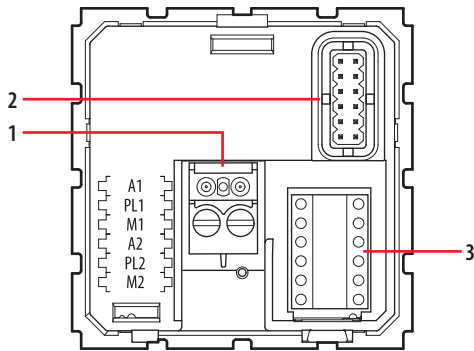

Legend

- 1. BUS clamp
- 2. Connector for connection to the actuator module
- 3. Configurator socket:
 - A1 = actuator area
 - PL1 = actuator light point
 - M1 = actuator mode
 - A2 = general command area
 - PL2 = general command light point
 - M2 = general command mode

Actuator module

Rear view

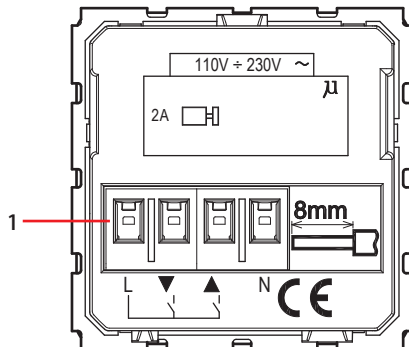

Front view

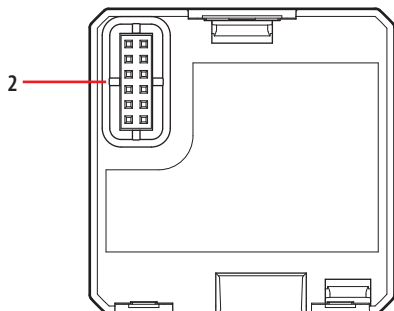

Legend

- 1. Load connection clamps
- 2. Connector for connection to the control module

List of functions

The device create the following functions:

- Actuator mode for shutter automation with local control
- 1 load actuator (shutter automation) with local control using the left button and remote actuator or scenario control using the right button
- Right key control operating mode
- Plus programmed scenario activation

Configuration

For device configuration and installation and for any other information, refer to the App or documentation that can be downloaded from the on-line catalogue of the device.

Download App



Home + Control



Home + Project

The apps can be downloaded from their respective stores. It is recommended to update the smartphone or tablet operating systems to the latest available version.

In addition, PHYSICAL CONFIGURATION will continue to be guaranteed by inserting the configurators in the appropriate housings (*).

The configuration using Home + Project has the advantage of offering many more options when compared with the physical configuration.

For the list of modes and the corresponding meanings refer to the indications of this technical sheet and the Home + Project app.

(*) Physical configuration

1. Actuator mode for shutter automation with local control

Configure A1, PL1 and M1 to define the address and mode of the local actuator.

1.1 Addressing

Address type		Configurators
Apartment	Room	A1=1 – 9
	Light point	PL1=1 – 9

1.2 Automation

Function	Configurators	
	Standard motor	Pulse motor
Shutter UP/DOWN with STOP. The actuator ignores Room and General controls	M1= PUL	M1= 6
Shutter UP/DOWN with STOP in slave mode	M1= SLA	M1= 7
Monostable UP/DOWN	M1= ↑↓M	M1= 4
Bistable UP/DOWN	M1= ↑↓ or 0	M1= 3
UP/DOWN monostable short pressure bistable long pressure	M1= 1	M1= 5

2. 1 load actuator (shutter automation) with local control using the left button and remote actuator or scenario control using the right button

2.1 Addressing

Configure A1, PL1 and M1 to define the address and mode of operation of the local actuator (controlled by the left key) as stated in sections 1.1 and 1.3.
Configure A2 and PL2 to define the address of the remote actuator to manage, as per the table below:

Address type		Configurators
Point-to-point	Room	A2= 1 – 9
	Light point	PL2= 1 – 9
Room		A2= AMB, PL2= 1 – 9
Group		A2= GR, PL2= 1 – 9
General		A2= GEN

2.2 Remote control operating mode

See chapter 3.

3. Right key control operating mode

3.1 ON/OFF control:

Function		Configurators
Cyclical		M2=0
ON		M2=ON
OFF		M2=OFF
Pushbutton		M2=PUL
Timed ON	0,5 sec	M2=8
	30 sec	M2=7
	1 min	M2=1
	2 min	M2=2

3.1.1 ON/OFF control and ADJUSTMENT (Point-to-Point only):

Function	Configurators
Cyclical ON/OFF and ADJUSTMENT. ON/OFF when pressing briefly and adjustment when holding down.	M2=0
ON with upper button, OFF with lower button and DIMMER when held down	M2=0/1

3.2. Automation control

3.2.1 Addressing

Address type	Configurators
Point-to-point	Room Light point
Room	A1, A2=1-9 PL1, PL2=1-9
Group	A1, A2=AMB, PL1, PL2=1-9
General	A1, A2=GR, PL1, PL2=1-9
	A1, A2=GEN

3.2.2 Mode

Function	Configurators
Bistable control	M1, M2=↑↓
Monostable control	M1, M2=↑↓M
Bistable control and blades control	M1, M2=6

4. Video door entry functions

4.1 Door lock release control

4.1.1 Addressing

Addressing type	Configurators
Entrance panel address	A=1-9 PL=1-9 ¹⁾

Note ¹⁾: Set the P address (two digits) of the entrance panel from which to control the door lock using the bottom left module. The bottom right module controls the door lock of entrance panel P+1 se A2=PL2=M2=0.

Type of function

Function	Configurators
Door lock release control	M1, M2=3

4.2 Floor call control

4.2.1 Addressing

Define the address (two digits) of the internal unit to be called using the control device.

Addressing type	Configurators
Internal unit address	A=1-9 PL=1-9
General	A=GEN A/PL=0

Type of function:

Function	Configurators
Floor call control	M=4

4.3 Staircase lights control

4.3.1 Addressing

The device takes on the function of pushbutton for switching on the lights of the internal unit identified by its own address (two digits).

Addressing type	Configurators
Internal unit address	A=1-9 PL=1-9

Type of function:

Function	Configurators
Staircase lights control	M=5

Calibration of the shutter position

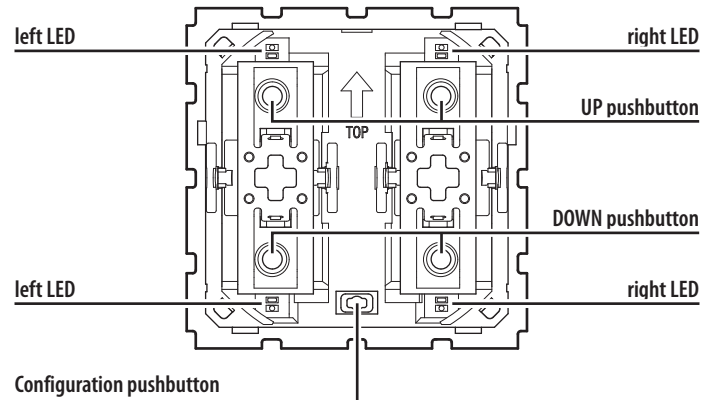

Manual calibration of the shutter position

This operation ensures that the actuator saves the shutter opening and closing positions.

1. Press the configuration pushbutton for at least 3 seconds. All the LEDs will come on blue.
2. Release the configuration pushbutton. The left LED will flash quickly.
3. Press and release the "UP" pushbutton. The shutter will move upwards, and the left LED will flash slowly.
4. Once the shutter has reached the maximum opening position, press the "DOWN" pushbutton. The shutter will move downwards, and the left LED will flash slowly. During this stage, the actuator measures and saves the time it takes the shutter to close.
5. When the shutter is fully closed, press and release the "UP" pushbutton. The shutter will move upwards to enable the actuator to measure and save the time it takes the shutter to open.
6. When the shutter maximum opening position is reached, press the "DOWN" pushbutton again to complete the calibration procedure. The left LED will return to white steady.

WARNING: the calibration precision, and therefore the control of the shutter position, depends on the accuracy with which the limit switch positions are manually detected during the calibration itself.

Saving the new shutter position (Preset)

The Preset function gives the possibility of setting the shutter in one of the 9 positions that can be selected through the configurator in the Pre socket. It is also possible to set a different position as required by the user. The procedure, which can be performed from the control device, or the actuator, is as follows:

7. Press the "UP" and "DOWN" pushbuttons to move the shutter to the desired position.
 8. Press the STOP pushbutton for at least 10 seconds. The actuator saves the position of the shutter.
 9. To confirm that the position has been saved correctly, the left LED will turn blue for 2 seconds.
- Irrespective of the shutter position, once this has been stopped by pressing the STOP pushbutton, it will be possible to move it to the preset position

Wiring diagrams

Wiring diagram for shutter connection

