

Actuator - Control for lights and generic loads

Description

Flush mounted two-module actuator / command with 2 independent relays and neutral for "zero crossing" function" - for single or double loads.

The actuator can also be configured to simultaneously handle the load connected to it and to act as a "control device" to manage one or more remote actuators, with typical operating modes of the 2-module base control. More specifically, after the configuration, it is possible to set the following modes of operation:

1. Actuator for single load (lighting) with local control.
2. Actuator for 2 independent loads (lighting) with 2 local controls.
3. Actuator for 1 load (lighting) with local control by the left button and remote actuator or scenario control by the right button.

The device consists of two separable parts: one part of contacts and one of control, in this way it is possible to wire them separately.

To be completed with 1 or 2-module covers.

In case of management of groups of lights, it is possible to configure the return state (please check the production date strating from 25W49).

Technical data

Operating voltage:	110 – 230 Vac
Operating power supply with SCS BUS:	22 – 27 Vdc
Power consumption at maximum LED intensity:	8.7 mA (stand-by) 17 mA (max – single load) 25.4 mA (max – double load)
Clamp dimension:	2 x 2,5 mm ²
Operating temperature:	0 – 40 °C

	Loads	Filament lamp or halogen lamp		LED (***)	
		Power (W)	Current (A)	Power (W)	Current (A)
A (*)	230 Vac	1380 W	6 A	250 W	1 A
	110 Vac	660 W	6 A	110 W	1 A
B (**)	230 Vac	460 W	2 A	-	-
	110 Vac	220 W	2 A	-	-

	Loads	Fluorescent compact		Electronic transformer		Ferromagnetic transformer	
		Power (W)	Current (A)	Power (W)	Current (A)	Power (Va)	Current (A) cosφ 0,5
A (*)	230 Vac	250 W	1 A	460 W	2 A	460 Va	2 A cosφ 0,5
	110 Vac	110 W	1 A	220 W	2 A	220 Va	2 A cosφ 0,5
B (**)	230 Vac	-	-	-	-	460 Va	2 A cosφ 0,5
	110 Vac	-	-	-	-	220 Va	2 A cosφ 0,5

(*) To use with connected neutral.

(**) To use without neutral (see paragraph 8).

(***) Or 10 maxi. lamps For good lighting comfort, we recommend the use of lamps of the same type and from the same supplier.

(****) **Caution:**

- Ferromagnetic transformers must be charged at over 60% of their rated power.
- During the calculation of the permitted power, take into account the performance of ferromagnetic transformers.
- A load must be connected before programming and using the product.

Control module front view

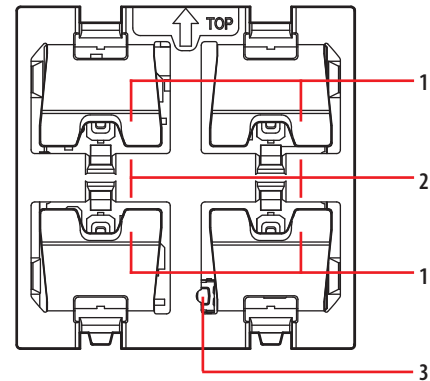

Control module rear view

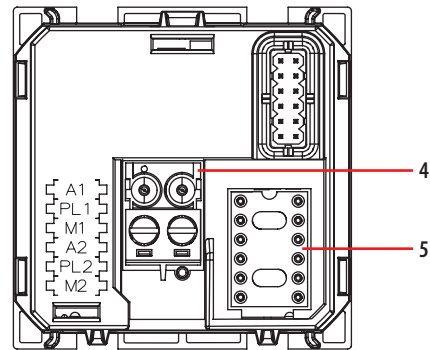

Relay module rear view

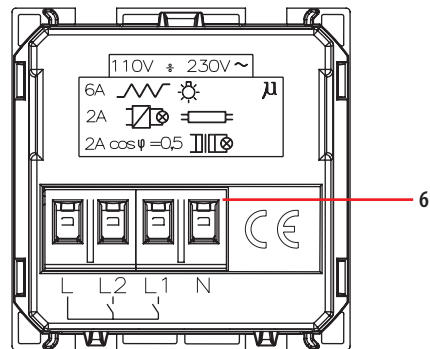

Legend

1. Control pushbuttons
2. Status notification LED
Blue steady: load ON
White steady: load OFF
Flashing: object not configured or no neutral
3. LED pushbutton
4. BUS connector
5. Configurator socket
6. Clamps (2 x 2.5 mm²) connection to the load

Actuator - Control for lights and generic loads

Dimensional data

Size: 2 flush mounted modules.

LED adjustment

After configuration, use the LED pushbutton to set the LED in the “always on” or “always off” status.

Press and hold down the pushbutton more than 2 seconds to change the status every 2 seconds. Release to confirm the desired status.

List of functions

The device performs the following functions:

1. LIGHTING ACTUATOR MODE (1 LOAD)
2. LIGHTING ACTUATOR MODE (2 SEPARATE LOADS) WITH LOCAL CONTROLS
3. ACTUATOR FOR 1 LOAD (LIGHTING) WITH LOCAL CONTROL BY THE LEFT BUTTON AND REMOTE ACTUATOR OR SCENARIO CONTROL BY THE RIGHT BUTTON
4. MODE OF OPERATION OF THE CONTROL BY THE RIGHT BUTTON
5. PLUS PROGRAMMED SCENARIO ACTIVATION
6. VIDEO DOOR ENTRY SYSTEM CONTROLS
7. COMMANDS ONLY AVAILABLE WITH VIRTUAL CONFIGURATION USING MyHOME_Suite AND MyHOME_Up
8. USE OF AN ACTUATOR WITHOUT NEUTRAL

See the following pages for the configuration procedures.

Configuration

For device configuration and installation and for any other information, refer to the App or documentation that can be downloaded from the on-line catalogue of the device.

Download App



Home + Project

Android: it is recommended the use of the latest version of Android with access to Google Play



iOS: it is recommended the use of the latest version of iOS or iPadOS



Apple, the Apple logo, Apple TV, Apple Watch, HomeKit, Apple Home, HomePod, HomePod mini, iPad, iPad Air, iPad mini, iPadOS, iPad Pro, iPhone, iPod, Mac, and Siri are trademarks of Apple Inc., registered in the U.S. and other countries. Multi-Touch and tvOS are trademarks of Apple Inc. App Store, iCloud+, and iTunes Store are service marks of Apple Inc., registered in the U.S. and other countries. IOS is a trademark or registered trademark of Cisco in the U.S. and other countries and is used under license. Other product and company names mentioned herein may be trademarks of their respective companies. Google, Google Home, Google Play, Android, and related marks and logos are trademarks of Google LLC. Amazon, Alexa and all related logos are trademarks of Amazon.com, Inc. or its affiliates.

In addition, you can configure the device using the MyHOME_Suite software, to have many more options of configuration, or physical configurators connected to the appropriate sockets.

1. Lighting Actuator Mode (1 load)

Configure A1, PL1 and M1 to define the address and mode of the local actuator, A2, PL2, M2=0.

1.1 Addressing

Address type		Virtual configuration (MyHOME_Suite)*	Physical configuration
Apartment	Room	0 – 10	A1=1 – 9
	Lighting point	0 – 15	PL1=1 – 9

*To configure the group address (1-10) from 0 to 255 use the MyHOME_Suite virtual configuration.

Actuator - Control for lights and generic loads

1.2 Lighting

Virtual configuration (MyHOME_Suite)*		Physical configuration	
Function	Parameter / setting		
Master Actuator - cyclic ON/OFF	Master	M1= 0	
ON with top button, OFF with bottom button	-	M1= 0/I	
Actuator as Slave. Receives a control sent by a Master actuator which has the same address	Slave		
Master Actuator - cyclic ON/OFF ignores Room and General controls	Master PUL Delay OFF = 0	M1= PUL	
Master Actuator with OFF control delayed on the corresponding Slave actuator. ¹⁾	Master PUL Delay OFF = 1 – 255	M1= 1	1 minute
		M1= 2	2 minutes
		M1= 3	3 minutes
		M1= 4	4 minutes

*To define the type of load (lamp, solenoid valve etc.) use the MyHOME_Suite virtual configuration.

Note: only for point-to-point control. With the OFF control the Master actuator is disabled, the Slave actuator is disabled after the time set in the Master actuator has elapsed. A function commonly used in windowless bathrooms, where the ON control simultaneously switches on the light (Master actuator) and the ventilation fan (Slave actuator). The following OFF control immediately switches off the light and keeps the fan on for the period of time set by the configurator 1÷4 inserted in M of the Master actuator as shown in the table.

2. Lighting Actuator Mode (2 separate loads) with local controls

In this mode, the actuator manages two separate loads, connected to the contacts C – L1 and C – L2 of the two relays, locally controlled with both front buttons, right (load connected in C – L2) and left (load connected in C – L1).

2.1 Addressing

Address type		Virtual configuration (MyHOME_Suite)*	Physical configuration
Apartment	Room	0 – 10	A1, A2= 1 – 9
	Lighting point	0 – 15	PL1, PL2= 1 – 9

*To configure the group address (1-10) from 0 to 255 use the MyHOME_Suite virtual configuration.

2.2 Lighting

Virtual configuration (MyHOME_Suite)*		Physical configuration		
Function	Parameter / setting			
Master Actuator - cyclic ON/OFF	Master	M2=0	M1=CEN	
ON with top button, OFF with bottom button	-	M2=0/I	M1=CEN	
Actuator as Slave. Receives a control sent by a Master actuator which has the same address	Slave	M2=SLA	M1=CEN	
Master Actuator - cyclic ON/OFF ignores Room and General controls	Master PUL Delay OFF = 0	M2=PUL	M1=CEN	
Master Actuator with OFF control delayed on the corresponding Slave actuator. ¹⁾	Master PUL Delay OFF = 1 – 255	M2=1	M1=CEN	1 minute
		M2=2	M1=CEN	2 minutes
		M2=3	M1=CEN	3 minutes
		M2=4	M1=CEN	4 minutes

*To define the type of load (lamp, solenoid valve etc.) use the MyHOME_Suite virtual configuration.

Note: only for point-to-point control. With the OFF control the Master actuator is disabled, the Slave actuator is disabled after the time set in the Master actuator has elapsed. A function commonly used in windowless bathrooms, where the ON control simultaneously switches on the light (Master actuator) and the ventilation fan (Slave actuator). The following OFF control immediately switches off the light and keeps the fan on for the period of time set by the configurator 1 – 4 inserted in M of the Master actuator as shown in the table.

Actuator - Control for lights and generic loads

3. Actuator for 1 load (lighting) with local control by the left button and remote actuator or scenario control by the right button

3.1 Addressing

Configure A1, M1 and PL1 to define the local actuator address and mode of operation (controlled by the left button) as specified in paragraphs 1.1 and 1.2. Configure A2 PL2 to define the address of the remote actuator to be managed, according to the following table:

Address type		Virtual configuration (MyHOME_Suite)	Physical configuration
Point-to-point	Room	0 – 10	A2= 1 – 9
	Lighting point	0 – 15	PL2= 1 – 9
Room		0 – 10	A2= AMB, PL2= 1 – 9
Group		1 – 255	A2= GR, PL2= 1 – 9
General		General	A2= GEN

4. Mode of operation of the control by the right button

4.1 ON/OFF control:

Virtual configuration (MyHOME_Suite)		Physical configuration
Function	Parameter / setting	
	Cyclic	M2=0
	ON	M2=ON
	OFF	M2=OFF
	Button	M2=PUL
Timed ON*	0,5 sec	M=8
	30 sec	M=7
	1 min	M=1
	2 min	M=2

* For other timing functions complete the virtual configuration using MyHOME_Suite.

4.1.1 ON/OFF Control and ADJUSTMENT (Point-to-Point only):

Virtual configuration (MyHOME_Suite)		Physical configuration
Parameter / setting		
ON/OFF and cyclic ADJUSTMENT. ON/OFF when pressing briefly and adjustment when holding down.		M1, M2=0
ON with top button, OFF with bottom button and DIMMER when held down		M1, M2=0/1

For the “ON/OFF with adjustment” function, “Cyclic with custom point-to-point adjustment”, “ON/OFF with custom point-to-point adjustment”, “Cyclic with custom adjustment” and “Custom cyclic dimmer with no adjustment” use virtual configuration via MyHOME_Suite.

With the virtual configuration, for the room, group or general controls, you can set a lighting point address for the return of the load status.

Actuator - Control for lights and generic loads

4.2. Automation control

4.2.1 Addressing

Address type		Virtual configuration (MyHOME_Suite)	Physical configuration
Point-to-point	Room	0-10	A1, A2=1-9
	Lighting point	0-15	PL1, PL2=1-9
Room		0-10	A1, A2=AMB, PL1, PL2=1-9
Group		1-255	A1, A2=GR, PL1, PL2=1-9
General		general	A1, A2=GEN

Note: With the virtual configuration, for the room, group or general controls, you can set a lighting point address for the return of the load status.

4.2.2 Mode

Virtual configuration (MyHOME_Suite) Parameter / setting	Physical configuration
Bistable control	M1, M2=↑↓
Monostable control	M1, M2=↑↓M
Bistable control and lath control	M1, M2=6

5. Plus programmed scenario activation

To configure address 1 - 2047 of the scenario and number 0 - 31 use MyHOME_Suite virtual configuration.

6. Video door entry system controls

6.1 Unlocking control

6.1.1 Addressing

Addressing type	Virtual configuration (MyHOME_Suite)	Physical configuration
Address of the external unit	0-95	A=1-9 PL=1-9 ¹⁾

Note ¹⁾: Set the P address (two digits) of the entrance panel from which to control the door lock using the left module. The right module controls the door lock of entrance panel P+1 if A2=PL2=M2=0.

Type of function

Virtual configuration (MyHOME_Suite)	Physical configuration
Door lock release control	M1, M2=3

6.2 Floor call control

6.2.1 Addressing

Define the address (two digits) of the internal unit to call by using the control device.

Addressing type	Virtual configuration (MyHOME_Suite)	Physical configuration
Address of the internal unit	0-99	A=1-9 PL=1-9
General	General	A=GEN A/PL=0

Type of function:

Virtual configuration (MyHOME_Suite)	Physical configuration
Function	
Floor call control	M=4

Actuator - Control for lights and generic loads

6.3 Control for stair lighting

6.3.1 Addressing

The device takes on the function of the stair lights power button of the internal unit identified by its address (two digits).

Addressing type	Virtual configuration (MyHOME_Suite)	Physical configuration
Address of the internal unit	0-99	A=1-9 PL=1-9

Type of function:

Virtual configuration (MyHOME_Suite)	Physical configuration
Function	
Staircase lights control	M=5

7. Commands only available with virtual configuration using MyHOME_Suite and MyHOME_Up

- Rolling shutter command with position control.
- Device lock/unlock command.
- Display of load control actuator.

8. Use of an actuator without neutral

Correct use of the product requires the connection of the neutral wire (see connection diagram). If the neutral is not connected the LEDs flash and the device will no longer perform any commands.

When the neutral cannot be brought to the product it will be used without neutral, with reduction of the outputs (see table of loads on page 1).

When configuring with MyHOME_Suite the product can be configured to work without neutral.

With a physical configuration, the actuator connected without neutral does not work (flashing LED). Unblock it as follows:

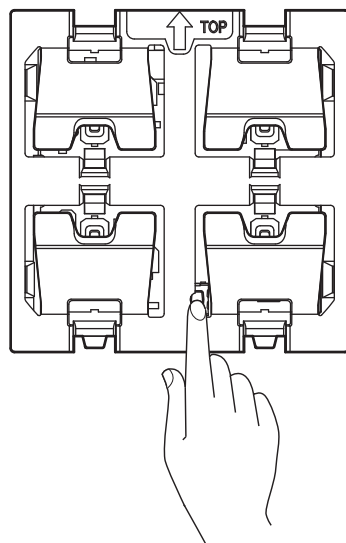

Within five minutes from switching on the product press the key indicated in the figure three times: the actuator stops flashing and unblocks.

Actuator - Control for lights and generic loads

Wiring diagrams

Wiring diagram for light connection

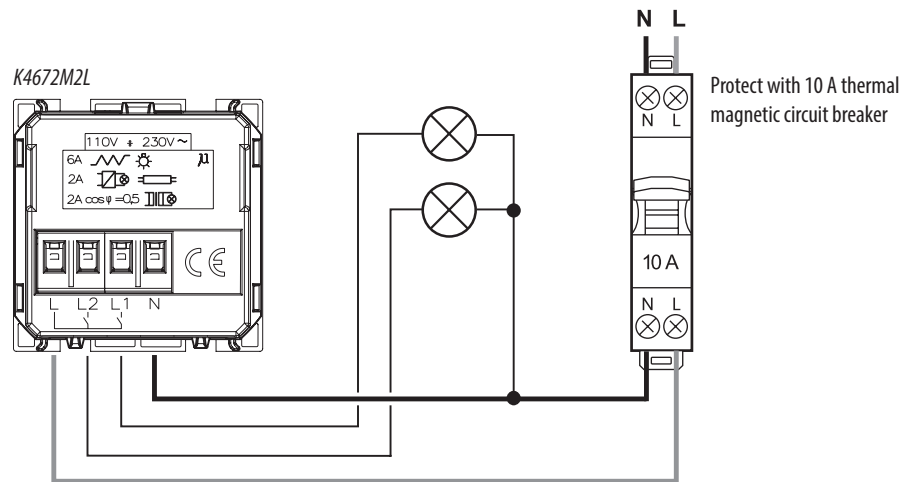

Wiring diagram for light without neutral connection

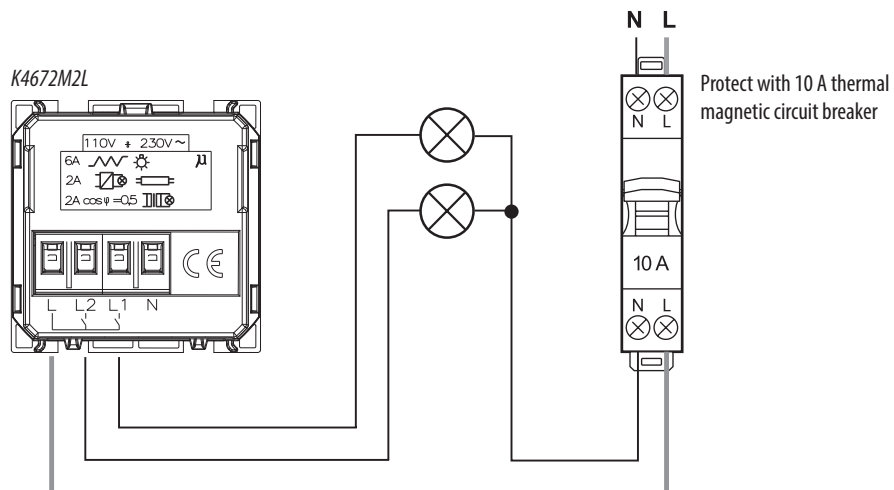

Note: to use without neutral (see paragraph 8).