

**CONTENTS**

Page

1. Description .....	1
2. Installation .....	2
3. Operation .....	3
4. Connection .....	4
5. Maintenance .....	5
6. Compliance and approvals .....	6
7. Equipment and accessories .....	6

**1. DESCRIPTION**

Background/emergency evacuation spotlight units IP 65 - IK 07 - Class II

Cat. No.	Flux/Battery life	Mode	NM pwr cons. (W)	Batteries	Product weight (kg)
6 614 60	1000 lm/1 hr	NM	0.7	LiFePO4	1.62

**• Dimensions**

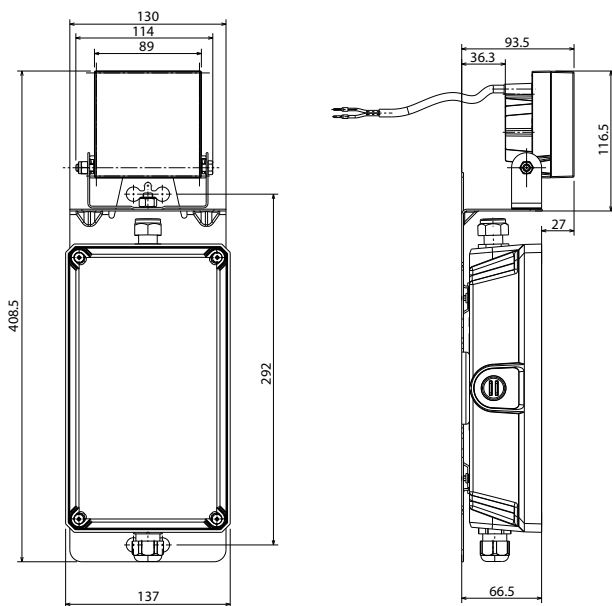

Product volume: 5 dm<sup>3</sup>

**• Technical characteristics**

Product for surface mounting on walls or ceilings  
 LED spotlight unit  
 Fitted with 1x2.5 mm<sup>2</sup> automatic connection terminals  
 Remote control input terminals protected against connection errors  
 Power supply: 230 V $\pm$  - 50/60 Hz  
 Operating temperature: 0°C to +35°C  
 Built-in remote control function allows it to be set to rest mode from the electrical panel if the lighting circuit is switched off intentionally.

**• Materials**

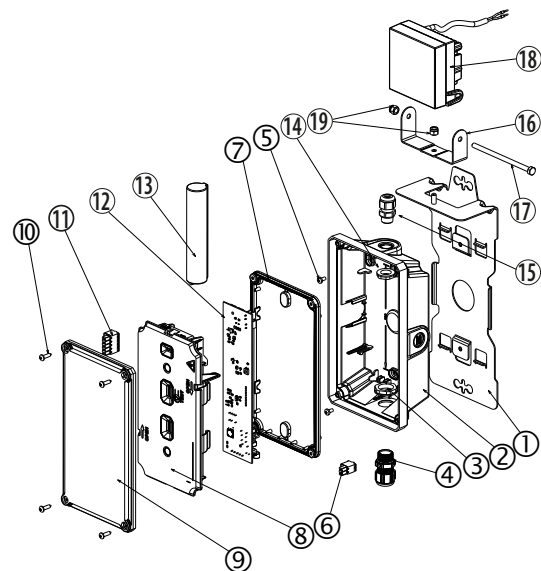

- ① Metal plate
- ② Weatherproof box: Black polycarbonate, self-extinguishing 850°C 30 s
- ③ PG13.5 cable gland locknut, black
- ④ Cable gland: polyamide self-extinguishing 850°C 30 s
- ⑤ M4x8 screw
- ⑥ Connector
- ⑦ Transparent seal: UV SEBS
- ⑧ Reflector: black polycarbonate, self-extinguishing 850°C 30 s
- ⑨ Diffuser: transparent polycarbonate, self-extinguishing 850°C 30 s
- ⑩ Pozidrive screw
- ⑪ Connector
- ⑫ Circuit board
- ⑬ Battery
- ⑭ PG9 cable gland locknut, black
- ⑮ Cable gland: polyamide self-extinguishing 850°C 30 s
- ⑯ Metal clamp
- ⑰ M6 x 110 screw
- ⑱ Spotlight

**1. DESCRIPTION (CONTINUED)**

• **Technical characteristics (continued)**

All plastic parts weighing more than 50 g are marked with their material type so that the materials can be recycled at the product's end of life.

• **Calorific value**

Thermal load of the plastic components of the casing: 14.3 MJ.

**2. INSTALLATION**

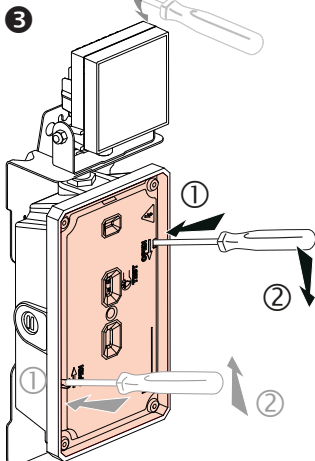
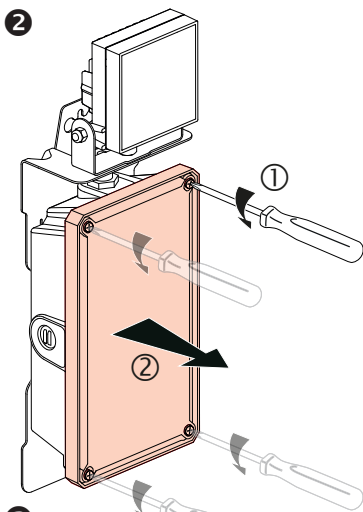
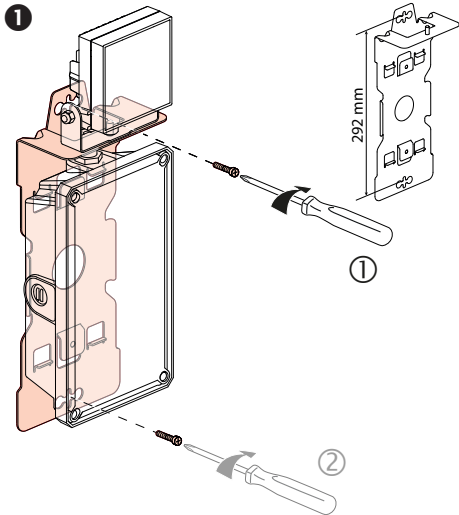

**2. INSTALLATION (CONTINUED)**

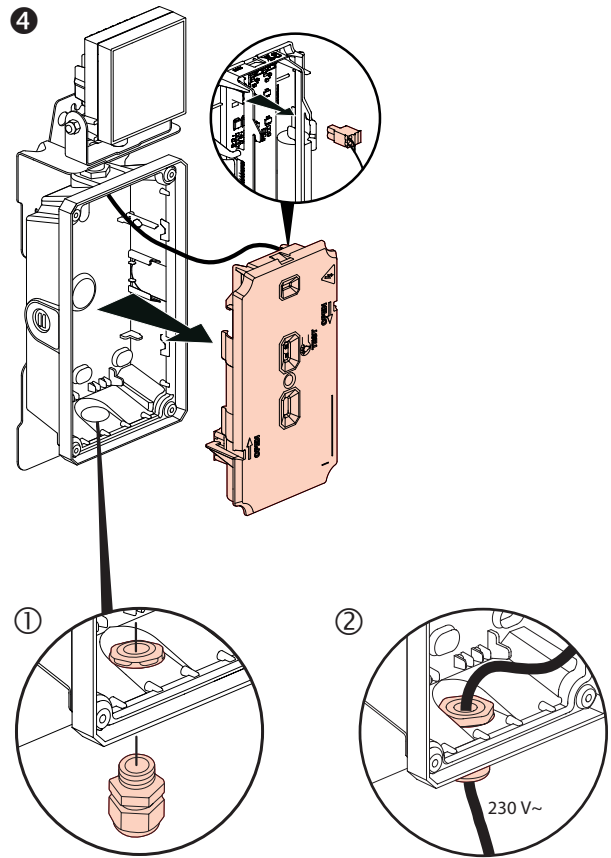

• **Connection**

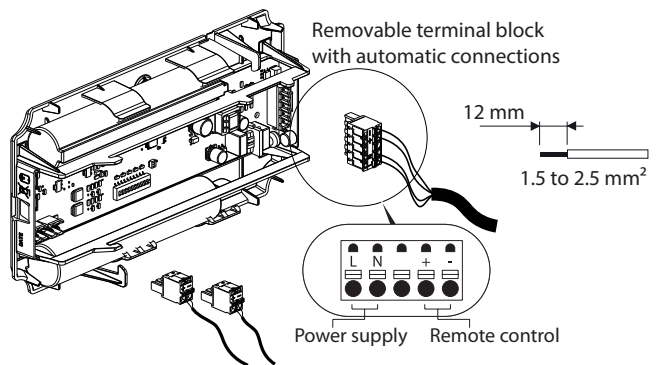

• **Ensuring the IP protection**

To ensure IP 65 protection, it is essential to use the cable gland and nut provided for the cable entry and to attach the diffuser using the 4 fixing screws provided.

As soon as installation is complete, attach a maintenance label Cat. No. 0 609 00 and write the commissioning date on it.

• **Ensuring the IK protection**

To ensure IK 07 protection, it is essential to fix the diffuser using the 4 fixing screws provided.

To ensure IK10 protection, add the protective grille Cat. No. 0 626 83 (see section 7. "Equipment and accessories").

**2. INSTALLATION (CONTINUED)**

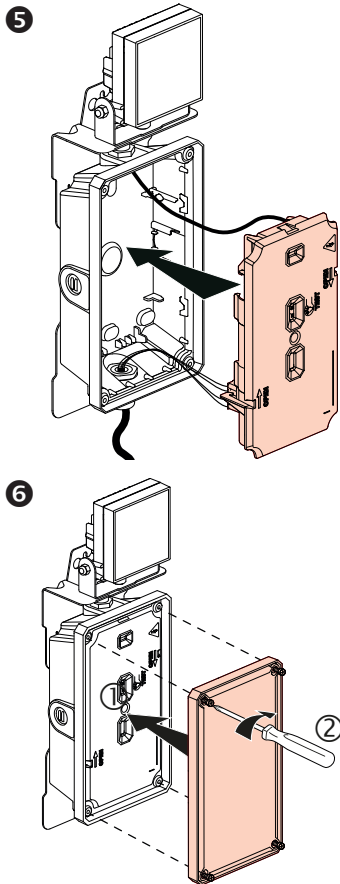

**3. OPERATION**

▪ **3.1 Switch-on/standby state**

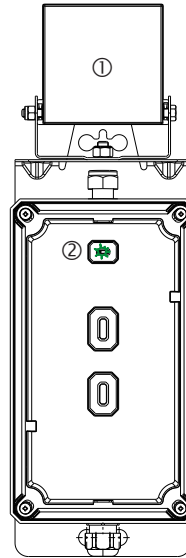

The spotlight is off ①  
 The green unit status LED comes on (flashing while the batteries are charging; 28 hours max.) ②

▪ **3.2 Mains supply break/emergency operation**

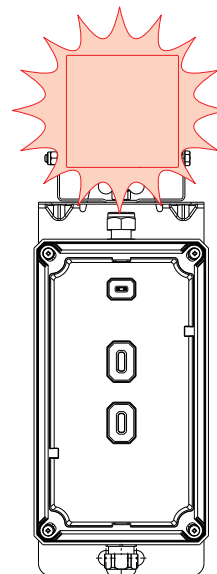

The spotlight comes on at the declared flux  
 The green unit status LED goes off

▪ **3.3 Setting to rest mode using remote controls 0 039 00/01**

**After the normal lighting is switched off intentionally:**

Pressing the Off  button sets the luminaire to rest mode to prevent the battery discharging.

**Normal lighting switched back on:**

The unit automatically returns to standby.

**3. OPERATION (CONTINUED)**

**3.4 Testing the units**

They can be tested by disconnecting the main power supply:  
 - They are working correctly if the spotlights come on.  
 - The rated standby power is correct if the spotlights stay on for the whole of the rated standby power time.

**3.5 Checking the spotlight**

**3.5.1 Checking the connection**

The spotlight operation and connection can be checked by pressing the "Test" button on the front.

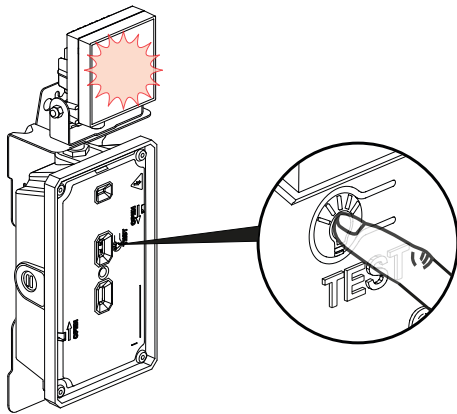

**3.5.2 Spotlight orientation**

The "Test" button can also be used to turn the spotlight light beam towards the installation without needing to power up the unit.

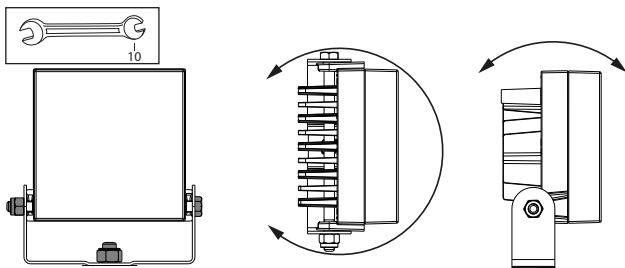

**4. CONNECTION**

**4.1 Connecting the units to the mains**

The branch can be joined in the electrical cabinet, on the switch or in a junction box.  
 The rules concerning the power supply are the same for emergency lighting as for any other type of luminaire.

**4. CONNECTION (CONTINUED)**

**4.1 Connecting the units to the mains (continued)**

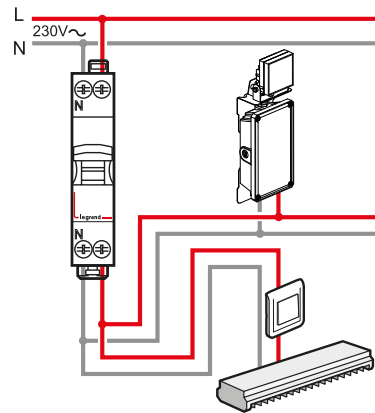

**4.2 Operation with remote control unit**

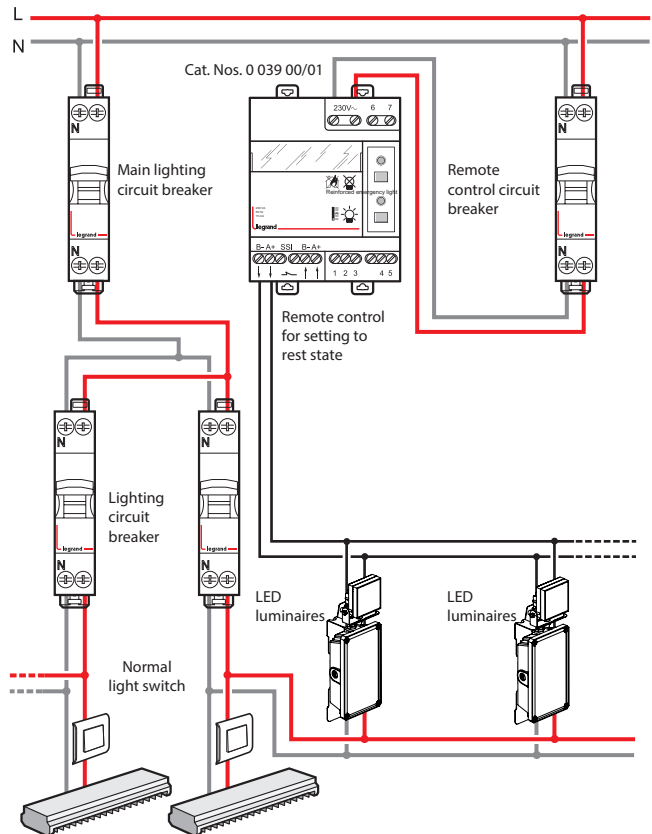

**Note:**  
 If performing a mains power present test (by pressing the ALL button on remote control 0 039 00/01), the units will follow the remote control commands:  
 1 s ON/4 s OFF/1 s ON; no need to press the EXT button to reset them to standby state.  
 If nothing happens, check the polarity of the remote control.  
 For the other catalogue numbers in this technical data sheet, the EXT button needs to be pressed to reset them to standby state.  
 In the event of interference on the remote control line or unwanted switching on of the self-contained emergency lighting units: add a 1K Ohm resistor between the A+ and B- terminals on remote control 0 039 00/01 (this resistor is supplied with the remote control).

**5. MAINTENANCE**

▪ 5.1 Troubleshooting

**Steady yellow LED:**

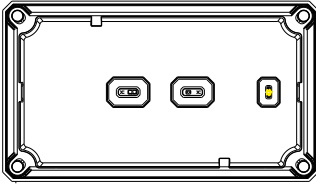

Check whether at least one of these faults is present:

- The battery is disconnected
- The battery has a voltage fault
- The battery has a standby power fault

▪ 5.2 Replacing the batteries

LifePO4 battery Type 6.4 V - 3.2 Ah Cat. No. 6 609 76

▪ 5.2 Replacing the batteries (continued)

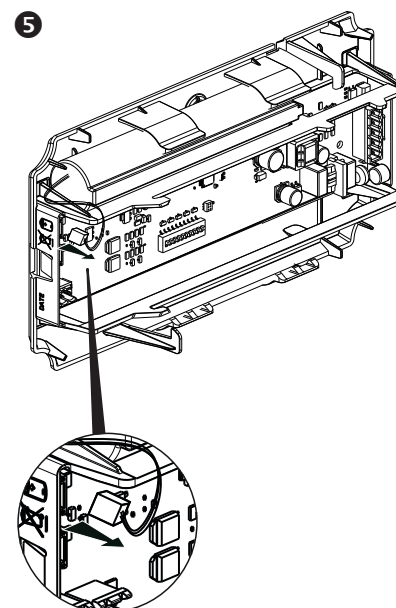
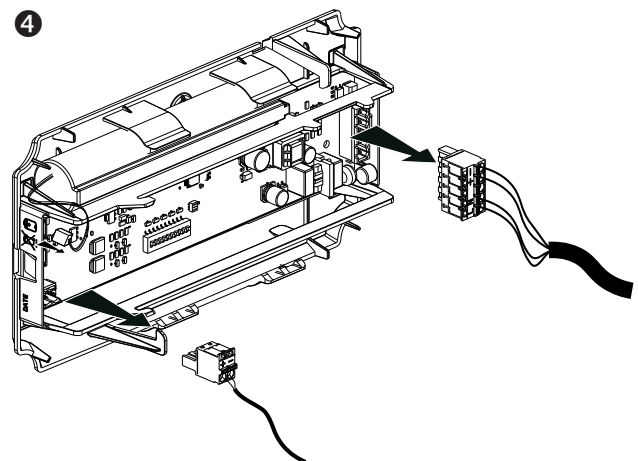
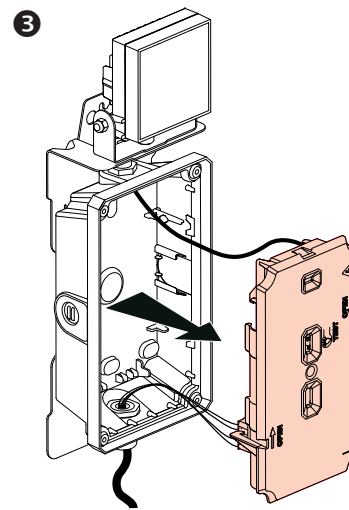
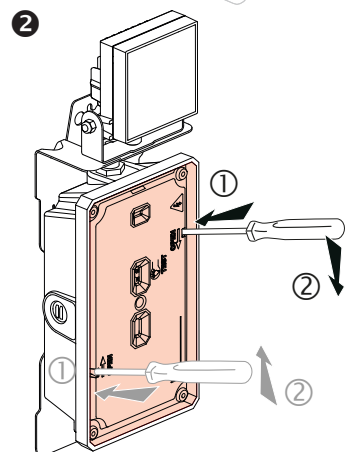
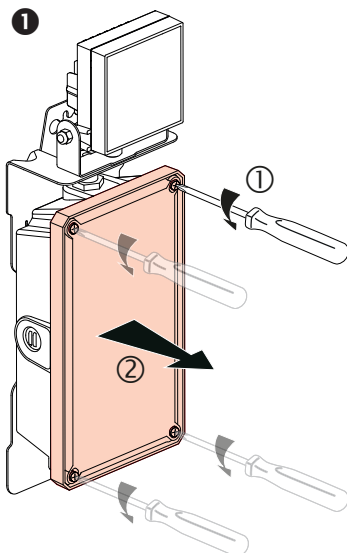

**5. MAINTENANCE (CONTINUED)**

▪ 5.2 Replacing the batteries (continued)

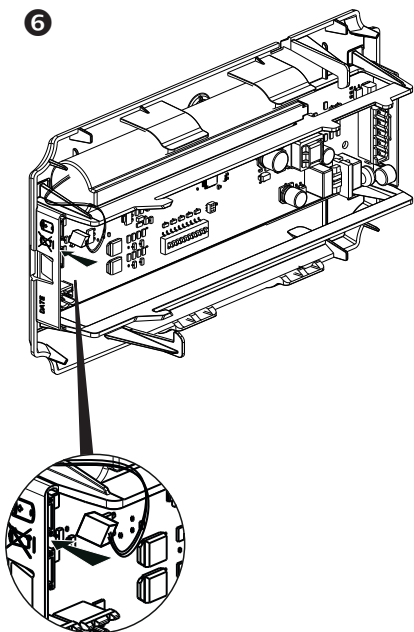
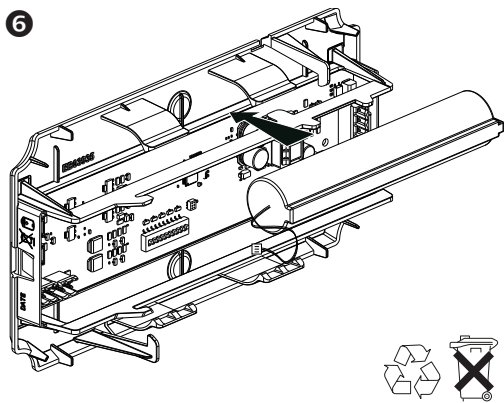
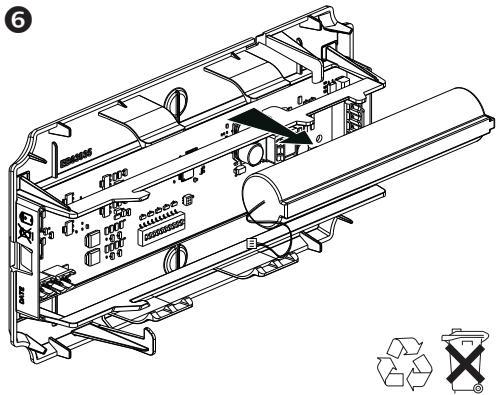

**5. MAINTENANCE (CONTINUED)**

▪ 5.2 Replacing the batteries (continued)

The batteries must be replaced when the self-contained unit can no longer provide its rated operating time (yellow LED on continuously).

**Important:** The product must be powered off before dismantling.

Legrand distribution partners take back used lighting units and batteries. When the batteries have been changed, replace the maintenance label, marking on it the date on which the unit was returned to service.

**6. COMPLIANCE AND APPROVALS**

EN IEC 60598-2-22: 2022: European standard "Luminaires: Particular requirements. Luminaires for emergency lighting"

EN IEC 60598-1 2021 + A1 2022: European standard "Luminaires"

EN IEC 62034: European standard "Automatic test systems for battery-powered emergency escape lighting".

Products certified with the AENOR N mark

Directives

- LV directive 2014/35/EU of 26/02/2014 and 2011/65/EU of 08/06/2011 amended by 2015/863 of 31/03/2015 (ROHS 2)

- EMC directive 2014/30/EU of 26/02/2014

**7. EQUIPMENT AND ACCESSORIES**

▪ 7.1 Standard protective grille Cat. No. 0 626 83

Impact resistance: IK 10 - 20 joules

Fixes over 4 holes on all sides

