

**KNX-Mallia Senses command 4/6/8 push with thermostat**

**Cat.No(s): 281027MW/DS/BB  
 281028MW/DS/BB  
 281029MW/DS/BB**

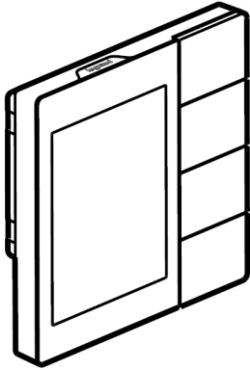

281027MW/DS/BB

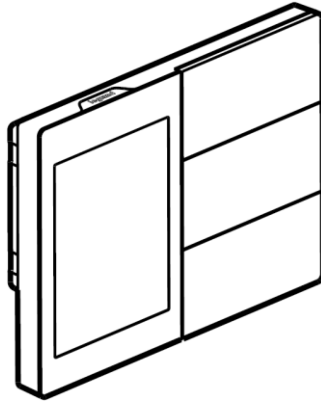

281028MW/DS/BB

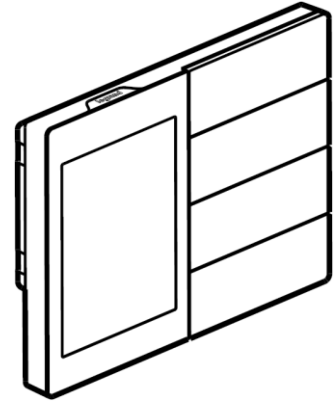

281029MW/DS/BB

<b>1. SUMMARY</b> .....	<b>3</b>
<b>2. TECHNICAL SPECIFICATINS AND DIMENSIONS, WIRING DIAGRAM</b> .....	<b>4</b>
<b>2.1. TECHNICAL PARAMETERS</b> .....	<b>4</b>
<b>2.2. DIMENSION AND WIRING DIAGRAM</b> .....	<b>5</b>
2.2.1. Dimensional drawing .....	5
2.2.2. Wiring diagram .....	5
<b>3. PARAMETER SETTING DESCRIPTION IN ETS</b> .....	<b>6</b>
<b>3.1. SUMMARY</b> .....	<b>6</b>
<b>3.2. GENERAL &gt; GENERAL SETTING</b> .....	<b>6</b>
<b>3.3. GENERAL &gt; PROXIMITY SETTING</b> .....	<b>7</b>
<b>3.4. BUTTON &gt; BUTTON SETTING</b> .....	<b>7</b>
<b>3.5. BUTTON &gt; BUTTON X</b> .....	<b>8</b>
3.5.1. Parameter setting interface "Disable" .....	8
3.5.2. Parameter setting interface "Switch" .....	8
3.5.3. Parameter setting interface "Dimming" .....	9
3.5.4. Parameter setting interface "Blind" .....	9
3.5.5. Parameter setting interface "Value output" .....	10
3.5.6. Parameter setting interface "Scene control" .....	10
<b>3.6. BUTTON &gt; LED FUNCTION</b> .....	<b>11</b>
<b>3.7. INTERNAL SENSOR &gt; MEASUREMENT SETTING</b> .....	<b>12</b>
<b>3.8. CONTROLLER &gt; CONTROLLER SETTING</b> .....	<b>12</b>
<b>3.9. HVAC CONTROLLER &gt; FCU SETTING</b> .....	<b>12</b>
3.9.1. HVAC controller >FCU setting>Setpoint.....	15
3.9.2. HVAC controller >FCU setting> Heating control .....	15
3.9.3. HVAC controller >FCU setting> Cooling control .....	17

3.9.4. HVAC controller >FCU setting>Heating /Cooling control.....	18
3.9.5. HVAC controller>FCU setting>Fan.....	18
3.9.6. HVAC controller>FCU setting>Scene.....	19
3.10. HVAC CONTROLLER>AC SETTING .....	20
3.10.1. HVAC controller > AC setting >Fan .....	22
3.10.2. HVAC controller>AC setting>Mode .....	22
3.10.3. HVAC controller>AC setting > Scene .....	23
3.11. HVAC CONTROLLER>VENTILATION SETTING .....	24
3.11.1. HVAC controller> Ventilation setting>Fan .....	25
3.11.2. HVAC controller > Ventilation setting > Mode .....	26
3.11.3. HVAC controller > Ventilation setting > Scene .....	26
3.12. HVAC CONTROLLER>FLOOR HEATING SETTING .....	27
3.12.1. HVAC controller>Floor heating setting > Scene.....	28
<b>4. COMMUNICATION OBJECT .....</b>	<b>29</b>
4.1. "GENERAL" COMMUNICATION OBJECT .....	29
4.2. "PROXIMITY FUNCTION" COMMUNICATION OBJECT .....	29
4.3. "BUTTON X- SWITCH" COMMUNICATION OBJECTS.....	30
4.4. "BUTTON X-DIMMING" COMMUNICATION OBJECTS.....	31
4.5. "BUTTON X-BLIND" COMMUNICATION OBJECT.....	32
4.6. "BUTTON X-VALUE OUTPUT" COMMUNICATION OBJECTS .....	33
4.7. "BUTTON X-SCENE CONTROL" COMMUNICATION OBJECT .....	34
4.8."LED X" COMMUNICATION OBJECTS.....	35
4.9. "INTERNAL SENSOR" COMMUNICATION OBJECT .....	35
4.10."FCU" COMMUNICATION OBJECTS .....	35
4.11."AC" COMMUNICATION OBJECTS .....	38
4.12."VENTILATION" COMMUNICATION OBJECT .....	40
4.13. "FLOOR HEATING" COMMUNICATION OBJECT.....	42

**1. SUMMARY**

KNX-Mallia Senses command push with thermostat series product is mainly used in the building control system, wall-mounted installation, which can be mounted on a conventional 86 junction boxes. These products are used to display status and control a variety of KNX devices, by common button and touching the icons in the interface to perform the preset function. Such as sending switch command, scene command, blind, Air conditioner control command, floor heating control command, fresh air control command, FCU control command to bus system, control other devices on the bus.

This manual provides users with detailed technical information about the panel, including installation and programming details, and explains how to use the key panel in connection with practical examples.

KNX-Mallia Senses command push with thermostat series product powered from KNX bus and need a 24-30V DC auxiliary supply voltage. It is available to assign the physical address and configure the parameters by engineering design tools ETS with .knxprod file( support edition ETS5.7 or higher )

The main functions of KNX-Mallia Senses command push with thermostat series product is shown as below:

- HVAC control
  - FCU control
    - ◆ Work mode
    - ◆ Setpoint or Actual temperature
    - ◆ Room temperature control mode
    - ◆ Room temperature operation mode
    - ◆ Fan speed
    - ◆ Timer
    - ◆ Scene
  - AC control
    - ◆ Support IR Split Unit air conditioning
    - ◆ Gateway Integrate controls
    - ◆ Setpoint
    - ◆ AC mode
    - ◆ Fan speed
    - ◆ Timer
    - ◆ Scene
  - Ventilation control
    - ◆ Fan speed

**1. SUMMARY (continues)**

- ◆ Mode
- ◆ Timer
- ◆ Scene
- ◆ Filter timer counter
- Floor Heating control
  - ◆ Setpoint
  - ◆ Timer
  - ◆ Scene
- Common button functions:
  - Switch
  - Dimming
  - Blind
  - Value output
  - Scene control
- The dual color LED indicator light of the button.
  - Cool white
  - Warm white
- Screen
  - LCD display
  - Capacitive touch buttons
  - Buzzer
- Proximity sensing, screen brightness adjustment.
- Built-in temperature sensor.

**2. TECHNICAL SPECIFICATIONS AND DIMENSIONS WIRING DIAGRAM****2.1. Technical parameters**

<b>Voltage</b>	KNX	21-30VDC, obtained via the KNX bus		
	Auxiliary	24-30VDC		
<b>Current (Consumption max)</b>	Reference	KNX (mA)	Auxiliary (mA)	Total (mA)
	281027MW/DS/BB	4	58	62
	281028MW/DS/BB	4	62	66
	281029MW/DS/BB	4	67	71
<b>Power consumption (Consumption max)</b>	Reference	KNX (W)	Auxiliary (W)	Total (W)
	281027MW/DS/BB	0.12	1.74	1.86
	281028MW/DS/BB	0.12	1.86	1.98
	281029MW/DS/BB	0.12	2.01	2.13
<b>The connection</b>	KNX	Bus connection terminal (diameter 0.8mm)		
	Auxiliary	Auxiliary connection terminal (diameter 0.8mm)		
<b>Operation and instructions</b>	Red LED and keys	Assign physical address		
	Each switch corresponds to one LED indicator, two indicator colors			
<b>Number of key operations</b>	>20000			
<b>Temperature range</b>	Operation	-5°C... +45°C		
	Storage	-25°C... +55°C		
	Transport	-25°C... +70°C		
<b>Environmental conditions</b>	Humidity	<93%, except for condensation		
<b>Proximity sensing distance</b>	10 cm. <b>Note:</b> Proximity sensing is based on infrared technology, and the distance of proximity sensing is affected by the volume and speed of the sensing object, which may become shorter or longer. If the usage environment is not suitable or this feature is not needed, please disable the proximity sensing function.			
<b>The installation</b>	Wall mount, first install the iron sheet bracket on the 86 boxes, then install the panel on the iron sheet bracket.			
<b>Color</b>	White, Silver and Brushed black totally 3 color available. <b>MW:</b> White, <b>DS:</b> Silver, <b>BB:</b> Brushed black			
<b>Size</b>	281027MW/DS/BB: 86mm×86mm×36.1mm			
	281028MW/DS/BB: 86mm×116mm×36.1mm			
	281029MW/DS/BB: 86mm×116mm×36.1mm			
<b>Weight</b>	281027MW/DS/BB: 0.125Kg			
	281028MW/DS/BB: 0.142Kg			
	281029MW/DS/BB: 0.142Kg			
<b>Certification</b>	Meet CE and KNX standards			

**2. TECHNICAL SPECIFICATINS AND DIMENSIONS WIRING**

**DIAGRAM (continues)**

■ **2.2. Dimension and wiring diagram**

■ **2.2.1. Dimensional drawing**

281027 MW/DS/BB (same as 281024MW/DS/BB) :

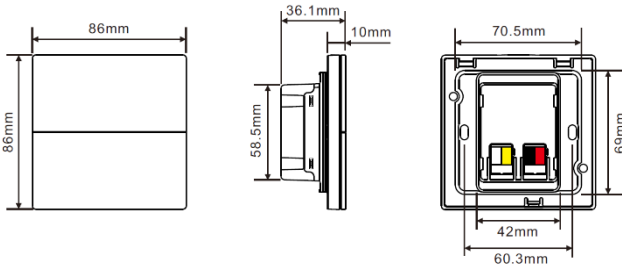

281028MW/DS/BB, 281029MW/DS/BB :

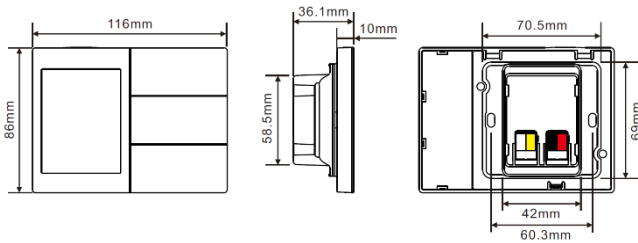

■ **2.2.2. Wiring diagram**

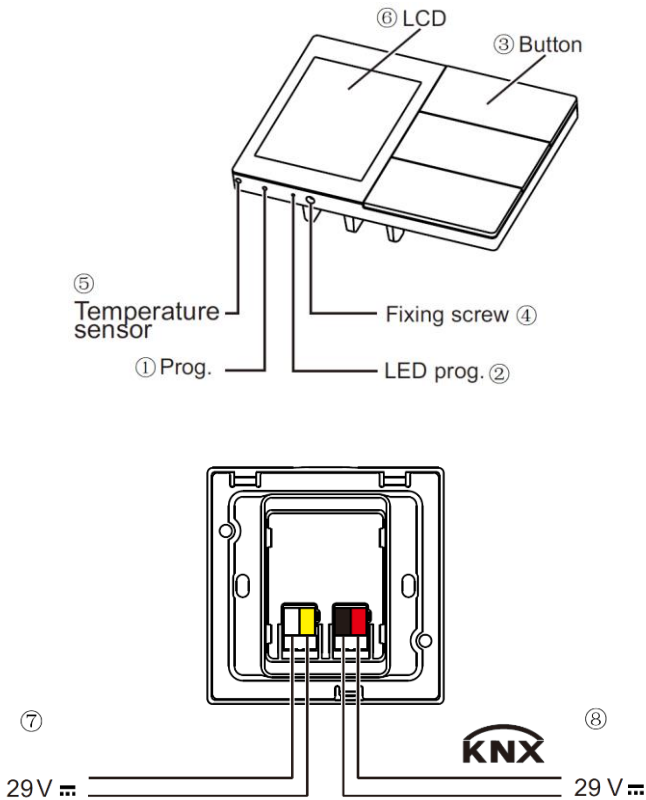

① Programming buttons

**2. TECHNICAL SPECIFICATINS AND DIMENSIONS WIRING**

**DIAGRAM (continues)**

- ② A red LED indicates to enter the physical address programming state and a green LED flashing indicates that the application layer of the device is working properly.
- ③ Button
- ④ Fixing screw
- ⑤ Temperature sensing element
- ⑥ LCD display screen
- ⑦ Auxiliary power connection terminals
- ⑧ KNX bus connection terminals

■ **2.3. Installation**

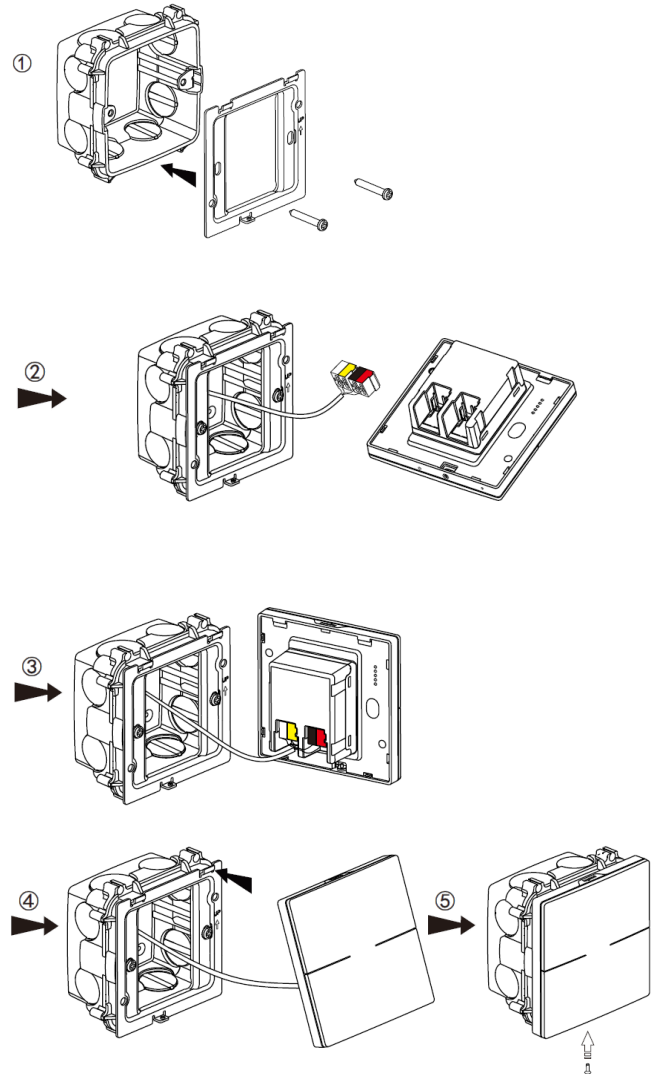

**3. PARAMETER SETTING DESCRIPTION IN ETS**

**3.1. Summary**

**General Features**

General features include backlight Settings for normal or standby working mode, press or touch volume Settings, proximity sensing function Settings, etc.

**Air conditioning controls**

There are two types of air conditioning control: split type infrared control and air conditioning gateway.

The split infrared function control is similar to the function on the air conditioning remote control. This function of the panel is to control the air conditioning through the infrared emission module on the bus. For example, the panel sends the control message to the infrared emission module, and the infrared emission module sends the function code given by the message to the air conditioning, so as to control the switch, mode, air volume and so on.

Air conditioning gateway control is suitable for control such as VRV air conditioning system, need to cooperate with the KNX to VRV air conditioning gateway control.

**Floor heating control**

Automatically switch the floor heating on and off according to the temperature difference. In addition, the floor heating scene function can be set, and the temperature setting value can be adjusted to the range of Settings.

**Fresh Air control system**

Support fresh air inlet and exhaust outlet configuration at the same time.

Support three speed adjustment.

Automatic control according to PM2.5 or CO2 concentration, In addition, scene function can also be set.

The following are common button functions:

**Switch**

This application is used for switch lighting, such as actuators, dimmers, etc. You can send a switch command by operating the switch button,

**Switch/dimmer**

This application is used for dimming lighting, distinguishing between long press and short press operation, two dimming modes are available, start and stop dimming and step dimming. Through this application, when operating the button of the switch, short press can send a switch command, long press can send a dimming command.

**3. PARAMETER SETTING DESCRIPTION IN ETS (continues)**

**Blinds control**

This application is used to trigger blinds or blackout curtains to move or adjust, distinguishing between long press and short press operation, sending different commands, such as: Switch short press operation sends a move command, long press operation sends an adjust or stop command.

**Value Output**

This application is used to send different values, the types of values are Options: 1bit,4bit,1byte,2byte, operation switch to send, each key can be set by short press and long press to send different values.

**Scenario Control**

Through this application, you can trigger or save the scene, such as: switch short press operation to activate scene, long press operation to save scene.

**LED function**

LED features are used for status indication or function indication. At the same time, it can indicate in different colors.

**3.2. General> General setting**

The "General setting" parameter setting interface shown as Figure 3.1

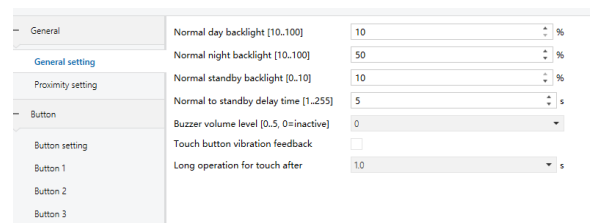

Figure 3.1 "General> General setting" parameter setting interface.

**Parameter "Normal day backlight [10..100] "**

This parameter for setting the screen backlight brightness of the day.

Options: 10...100

**Parameter "Normal night backlight [10..100] "**

This parameter for setting the screen backlight brightness at night.

Options: 10...100

**Parameter "Normal standby backlight [0..10] "**

This parameter for setting standby screen backlight brightness.

Options: 0...10

**3. PARAMETER SETTING DESCRIPTION IN ETS (continues)**

**Parameter "Normal to standby delay time [0..255,0=inactive]"**

This parameter for setting the delay time to enter the standby mode of screen.

Options: 0...255, 0= inactive

**Parameter "Buzzer volume level [0..5, 0=inactive]"**

This parameter for setting the volume of touch.

Options:0...5, 0=inactive

**Parameter "Touch button vibration feedback"**

For setting whether to enable vibration feedback when touched.

**Parameter "Long operation for touch after"**

Defines long operation time

Options:

- 1.5
- 1.0
- 2.0
- 3.0

**3.3. General>Proximity setting**

The Proximity setting interface shown as Figure 3.2. On the Proximity setting interface, you can configure the proximity Setting for the device.

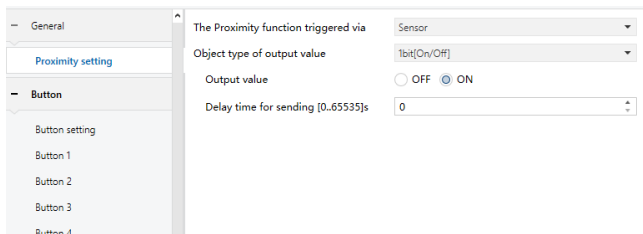

Figure 3.2 The "General>Proximity setting" parameter setting interface.

**Parameter "The Proximity function triggered via"**

Setting for screen wake up mode.

Options:

- Disable
- Sensor
- Proximity object
- Sensor or Proximity object

**Note 1:** 281027BB, 281028BB, 281029BB These three devices not have this funtion.

**Parameter "Object type output value":**

For setting the object type of output value to the bus when proximity approaching.

Options:

**3. PARAMETER SETTING DESCRIPTION IN ETS (continues)**

No reaction

1bit(On/Off)

1byte(sence control)

When parameter "Object type output value" set as "1bit(On/Off)" or "1byte(sence control)", set next parameter

**Parameter "Output value"**

The "Object type output value" parameter jointly determines the value of the Proximity output of an object.

When parameter "Object type output value" set as "1bit(On/Off)"

Options:

- OFF
- ON

When parameter "Object type output value" set as "1byte(sence-control)"

Options:

- Sense NO.1: Output value "1"
- Sense NO.2: Output value "2"
- ...
- Sense NO.63: Output value "63"
- Sense NO.64: Output value "64"

**parameter "Delay time for sending [0..65535]s"**

This parameter setting the delay time for sending telegram.

Options: 0...255.

**3.4. Button>Button setting**

The parameter setting interface of "Button setting" shown as Figure 3.3. The settings of this screen are applied to all keys of the device. In the introduction below, "Button X" means the one key button of the device. Each button on the device has the same parameter setting interface and communication object.

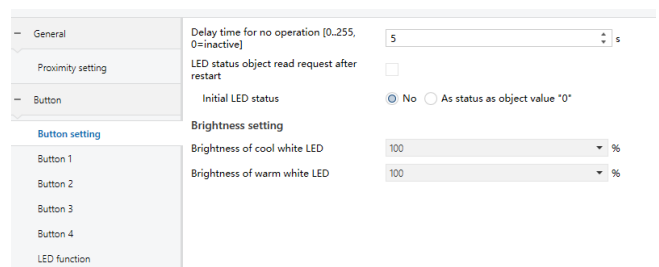

Figure 3.3 "Button setting" parameter setting interface

**Parameter "Delay time for no operation [0..255, 0=inactive]"**

Setting the delay time to enter the standby mode of button.

Options: 0...255, 0=inactive

**3. PARAMETER SETTING DESCRIPTION IN ETS (continues)**

**Parameter "LED status object read request after restart"**

Setting whether to read LED status after device restart.  
If not need to read. Set next parameter.

**Parameter "Initial LED status"**

Setting the Initial LED status.

Options:

- NO
- As status as object value "0"
- Brightness setting
- Parameter "Brightness of cool white LED"
- Parameter "Brightness of warm white LED"

These two parameters for Setting the Brightness of LED.

Options:

- 0
- 10
- 20
- ...
- 100

**3.5. Button > Button X**

Parameter setting interface "Button X" shown as Figure 3.4, it is mainly for setting specific parameters of button. The setting interface of all button is the same.

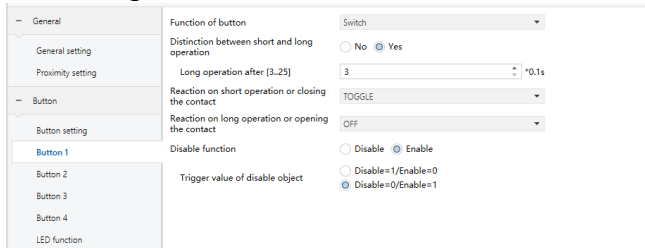

Figure 3.4 "Button X" parameter setting interface

**Parameter "Function of button"**

Setting function of button X

Options:

- Disable
- Switch
- Dimming
- Blind
- Value output
- Scene control

**3. PARAMETER SETTING DESCRIPTION IN ETS (continues)**

**3.5.1. Parameter setting interface "Disable"**

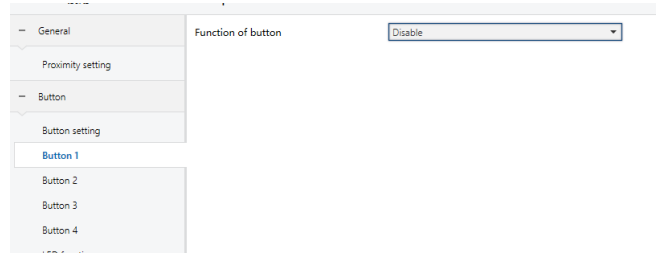

Figure 3.5 "Button X-Disable" parameter setting interface

When the parameter "Function of button" selection set as "Disable", the "Disable" setting interface shown as Figure 3.5 will appear, with the key button set to no function.

**3.5.2. Parameter setting interface "Switch"**

When the parameter "Function of button" set as "Switch", the "Button X-Switch" parameter setting interface is visible shown as Figure 3.6

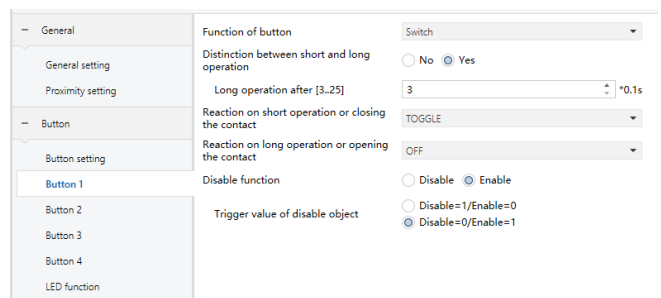

Figure 3.6 "Button X-Switch" parameter setting interface

**Parameter "Distinction between short and long operation"**

Setting whether to distinguish between short and long operation.

Options:

- NO
- YES

When parameter "Distinction between short and long operation" set as "YES", set next parameter.

**Parameter "Long operation after [3..25]"**

Setting for how long to press button is defined as a long operation.

Options: 3...25

**Parameter "Reaction on short operation or closing the contact"**

**Parameter "Reaction on long operation or opening the contact"**

These two parameters are setting the reaction of button operation for switch.



**3. PARAMETER SETTING DESCRIPTION IN ETS (continues)**

Options:

- No action
- ON
- OFF
- TOGGLE

**Parameter “ Disable function ”**

Setting whether to enable or disable switch function of button through object.

If enable set next parameter.

**Parameter “Trigger value of disable object”**

Setting to disabled switch function of button.

Options:

- Disable=1/Enable=0
- Disable=0/Enable=1

**3.5.3. Parameter setting interface “Dimming”**

When the parameter "Function of button" selection set as "Dimming", set the relative parameter of "Dimming" on the "Button X- Dimming" parameter setting interface shown as Figure 3.7

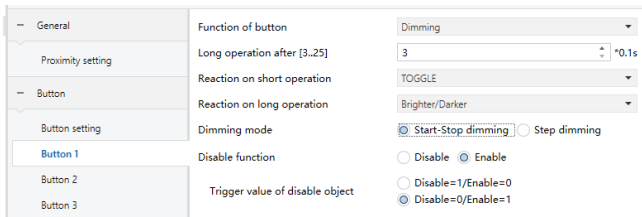

Figure 3.7 “Button X- Dimming” Parameter setting interface

**Parameter “ Long operation after [3..25] ”**

Setting for how long to press button is defined as a long operation.

Options: 3...25

**Parameter “ Reaction on short operation ”**

Setting the reaction of button short operation

Options:

- No action
- ON
- OFF
- TOGGLE

**Parameter “ Reaction on long operation ”**

**3. PARAMETER SETTING DESCRIPTION IN ETS (continues)**

Setting the reaction of button long operation

Options:

- No action
- Brighter
- Darker
- Brighter/darker

**Parameter “Dimming mode”**

Setting the dimming mode.

Options:

- Start-stop dimming
- Step dimming

When Parameter “Dimming mode” set as “Step dimming”, set next two parameters.

**Parameter “Step size”**

Setting the step value of. Step dimming

Options:

- 1/1 100%
- 1/2 50%
- 1/4 25%
- 1/8 12%
- 1/16 6%
- 1/32 3%
- 1/64 1%

**Parameter “Interval of tele. cyclic send [0..25,0-send once]”**

Setting the time for cyclical sending telegram in step dimming mode when long operation

Options: 0...25, 0-send once

**3.5.4. Parameter setting interface “Blind”**

When the parameter "Function of button" selection set as "Blind", set the relative parameter of " Blind " on the "Button X- Blind " parameter setting interface shown as Figure 3.8

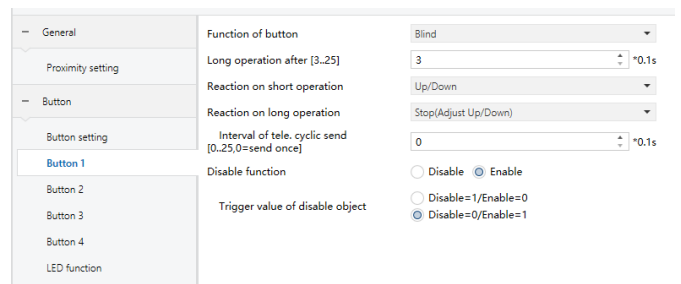

Figure 3.8 “Button X- Blind “Parameter setting interface.

**3. PARAMETER SETTING DESCRIPTION IN ETS (continues)**

**Parameter“ Long operation after [3..25]”**

Setting for how long to press button is defined as a long operation.

Options: 3...25

**Parameter“ Reaction on short operation”**

Setting the reaction of button short operation

Options:

- No action
- Up
- Down
- Up/Down

**Parameter“ Reaction on long operation”**

Setting the reaction of button long operation

Options:

- No reaction
- Up
- Down
- Up/Down
- Stop(Adjust Up)
- Stop(Adjust Down)
- Stop(Adjust Up/Down)

**Parameter “Interval of tele. cyclic send [0..25,0-send once] ) ”**

Setting the time for cyclical sending telegram of blind function when long operation

Options: 0...25, 0-send once.

**■ 3.5.5. Parameter setting interface “Value output”**

When the parameter "Function of button" selection set as "Value output", set the relative parameter of " Value output "on the "Button X- Value output " parameter setting interface shown as Figure 3.9

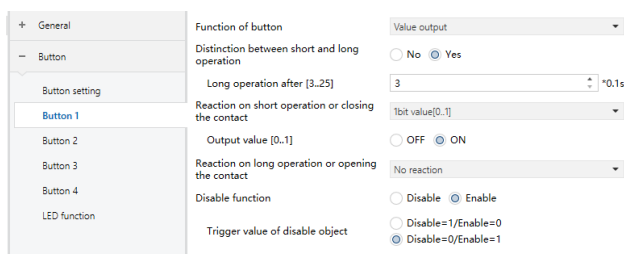

Figure 3.9“Button X- Value output “Parameter setting interface

**3. PARAMETER SETTING DESCRIPTION IN ETS (continues)**

**Parameter“Distinction between short and long operation”**

Setting whether to distinguish between short and long operation.

Options:

- No
- YES

When parameter "Distinction between short and long operation" set as "YES", set next parameter.

**Parameter “Long operation after [3..25]”**

Setting for how long to press button is defined as a long operation.

Options: 3...25

**Parameter“Reaction on short operation or closing the contact”**

**Parameter“Reaction on long operation or closing the contact”**

These two parameters are setting the output value of button operation for value output.

Options:

- No reaction
- 1bit value[0..1]
- 4bit value [0..15]
- 1byte value[0..255]
- 2byte value[0..6535]

**Parameter“Output value [0..1]”**

**Parameter“Output value [0..15] ”**

**Parameter“Output value [0..255] ”**

**Parameter“Output value [0..6535] ”**

Setting the output value for parameter “Reaction on short operation or closing the contact” and parameter “Reaction on long operation or closing the contact”.

Options:

- 0...1
- 0...15
- 0...255
- 0...6535

**■ 3.5.6. Parameter setting interface “Scene control”**

When the parameter "Function of button" selection set as "Scene control", set the relative parameter of "Scene control" on the "Button X- Scene control " parameter setting interface shown as Figure 3.10.

3. PARAMETER SETTING DESCRIPTION IN ETS (continues)

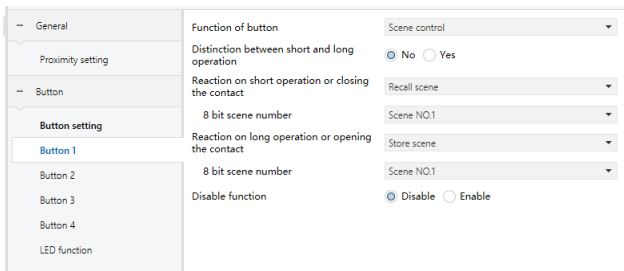

Figure 3.10 "Button X-Scene control" Parameter setting interface

**Parameter "Distinction between short and long operation"**

Setting whether to distinguish between short and long operation.

Options:

- No
- YES

When parameter "Distinction between short and long operation" set as "YES", set next parameter.

**Parameter "Long operation after [3..25]"**

Setting for how long to press button is defined as a long operation.

Options: 3...25

**Parameter "Reaction on short operation or closing the contact"**

**Parameter "Reaction on long operation or closing the contact"**

These two parameters are setting the reaction of button operation for scene control.

Options:

- No reaction
- Recall scene
- Store scene

**Parameter "8 bit scene number"**

Setting the scene number.

Options:

- Scene NO.1
- Scene NO.2
- Scene NO.3
- ...
- Scene NO.6
- Scene NO.7
- Scene NO.8

3. PARAMETER SETTING DESCRIPTION IN ETS (continues)

■ 3.6. Button > LED function

Parameter setting interface "Button > LED function" shown as Figure 3.11, it is mainly for setting related parameters of LED function.

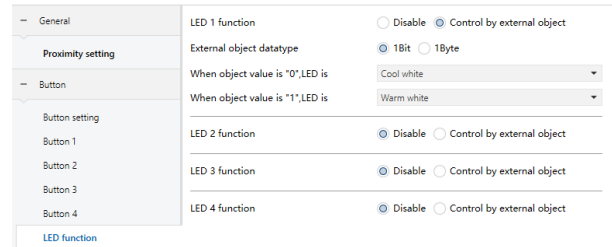

Figure 3.11 Button > LED function Parameter setting interface

**Parameter "LED X function"**

Setting whether enable the LED indicator function.

Options:

- Disable
- Control by external object

**Parameter "External object datatype"**

This parameter setting the datatype of external object.

Options:

- 1Bit
- 1Byte

When parameter "External object datatype" set as "1Bit", set the next two parameters

**Parameter "When object value is "0", LED is"**

Setting the LED indication status after receive telegram "0" from bus.

Options:

- OFF
- Warm white
- Cool white

**Parameter "When object value is "1", LED is"**

Setting the LED indication status after receive telegram "0" from bus.

Options:

- OFF
- Warm white
- Cool whitefour

When parameter "External object datatype" set as "1Byte", set the next four parameters

**3. PARAMETER SETTING DESCRIPTION IN ETS (continues)**

Parameter “Threshold value is”

Parameter “If object value < threshold value, LED is”

Parameter “If object value = threshold value LED is”

Parameter “If object value > threshold value, LED is”

These four parameters setting the threshold value for LED indicate status switcher.

Options:

- OFF
- Warm white
- Cool white

**■ 3.7. Internal sensor > Measurement setting**

Parameter setting interface “Internal sensor > Measurement setting” shown as Figure 3.12, it is mainly for setting related parameters of internal sensor detection, such as temperature.

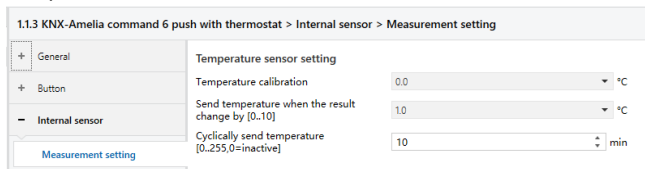

Figure 3.12 Internal sensor > Measurement setting Parameter setting interface

Temperature sensor setting

Parameter “Temperature calibration”

This parameter for setting the temperature calibration value of the internal sensor, that is, to calibrate the measured value of internal sensor to make it closer to the current ambient temperature.

Options:

- 5°C
- ...
- 0°C
- ...
- 5°C

Parameter “Send temperature when the result change by [0..10]”

This parameter for setting when temperature turns to a certain value, send the actual temperature value to the bus.

Options: 1...20

Parameter “Cyclically send temperature [0.255.0-inactive]”

Setting the time for cyclically sending the temperature detection value to the bus.

Options: 0...255min

**3. PARAMETER SETTING DESCRIPTION IN ETS (continues)**

**■ 3.8. Controller > Controller setting**

HVAC is mainly used to control the room temperature, automatically and optimally control the heating and cooling according to the use of the room or the needs of the occupants.

Supports manually switching of heating/cooling control, support options for three-level fan speed and auto fan speed, four operation modes: comfortable, standby, economy and protection mode.

The setting temperature supports absolute and relative settings, as well as adjustable temperature range settings.

Supports 2-point and PI control.

The “Controller setting” parameter setting interface shown as Figure 3.12

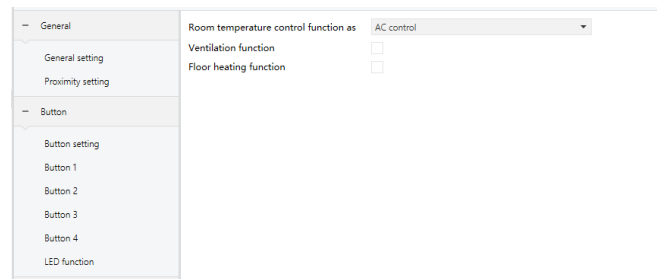

Figure 3.12 HVAC controller > Controller setting interface

Parameter “Room temperature control function as”

Temperature control function selection

Options:

- Disable
- FCU control
- AC control

Parameter “Ventilation function”

Whether the Ventilation function is enabled.

Parameter “Floor heating function”

Whether the Floor heating function is enabled.

**■ 3.9. HVAC controller > FCU setting**

Parameter setting interface “FCU setting” shown as Figure 3.13, it is mainly for setting related parameters of FCU, such as Work mode . Room temperature control mode and so on. Before setting this interface “Room temperature control function as” set as “FCU control” on the “Controller setting” setting interface.

**3. PARAMETER SETTING DESCRIPTION IN ETS (continues)**

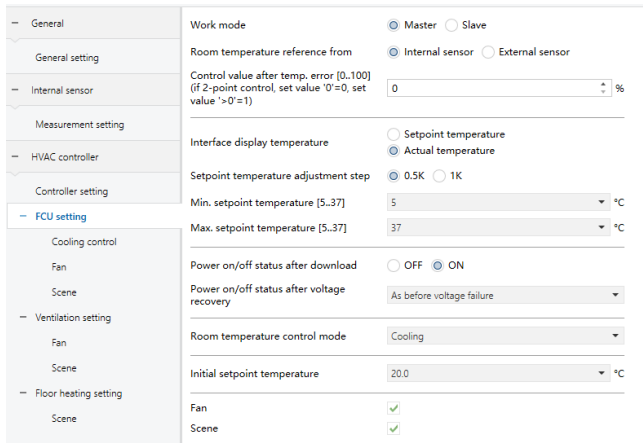

Figure 3.13 HVAC controller > FCU setting Parameter setting interface.

**Parameter “Work mode”**

Choice the FCU Work mode.

Options:

- Master
- Slave

**Parameter “Room temperature reference from”**

Setting room temperature of FCU from external or internal sensor detection.

Options:

- Internal sensor
- External sensor

**Parameter “Control value after temp. error [0..100] (if 2-point control, set value '0'=0, set value '>0'=1) ”**

Setting Control value of FCU when temperature detection wrong, Options: 0...100

After the temperature is powered on, an error message is returned. If the device is a two-pipe device, the switch is ON/OFF, and the PI algorithm controls “set value.”

**Parameter “Interface display temperature”**

Setting which show on the device.

Options:

- Setpoint temperature
- Actual temperature

**Parameter “Setpoint temperature adjustment step”**

Setting the temperature step value

Options:

- 0.5K
- 1K

**3. PARAMETER SETTING DESCRIPTION IN ETS (continues)**

**Parameter “Min. setpoint temperature [5..37] ”**

**Parameter “Max. setpoint temperature [5..37] ”**

These two parameters setting the adjustment range for limiting the setting temperature. The setting minimum value should be less than the maximum value.

If the setting temperature beyond the range, then output the limited value.

Options: 0...37

**Parameter “Power on/off status after download”**

Setting for the power on/off status of FCU interface after application downloaded.

Options:

- Off
- On

**Parameter “Power on/off status after voltage recovery”**

Setting for the power on/off status of floor heating interface after the bus recovery.

Options:

- Off
- On

**Parameter “Room temperature control mode”**

This parameter for setting FCU control mode.

Options:

- Heating
- Cooling
- Heating and Cooling

When “Room temperature control mode” set as “Heating”.

Set the parameters shown as Figure 3.14

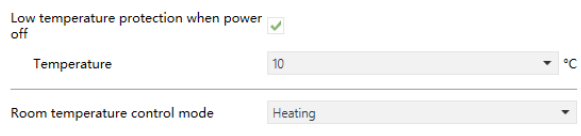

Figure 3.14

**Parameter “Low temperature protection when power off”**

Setting for sending setpoint temperature to Heat when FCU power on if ambient temperature is lower than “Low temperature protection” when FCU power off.

Temperature:5...10

When “Room temperature control mode” set as “Heating and Cooling” Set the parameters shown as Figure 3.15

**3. PARAMETER SETTING DESCRIPTION IN ETS (continues)**

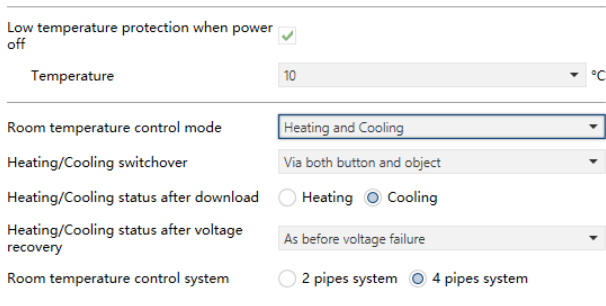

Figure 3.15

**Parameter “Low temperature protection when power off”**

Setting for sending setpoint temperature to heat when FCU power on if ambient temperature is lower than “Low temperature protection” when FCU power off.

Temperature:5...10

**Parameter “Heating/Cooling switchover”**

Setting how to make switchover for “Heating/Cooling.”

Options:

- Only via button
- Only via object
- Via both button and object
- Automatic changeover

**Parameter “Heating/Cooling status after download”**

Setting Heating or Cooling of FCU after download”

Options:

- Heating
- Cooling

**Parameter “Heating/Cooling status after voltage recovery”**

Setting Heating or Cooling of FCU after voltage recovery”

Options:

- Heating
- Cooling
- As before voltage failure

**Parameter “Room temperature control system”**

Setting Room temperature control system

Options:

- 2pipes system
- 4pipes system

**Parameter “Room temperature operation mode”**

Enable Room temperature operation mode or not.

**3. PARAMETER SETTING DESCRIPTION IN ETS (continues)**

When Enable Room temperature operation mode. Set the parameters shown as Figure 3.16

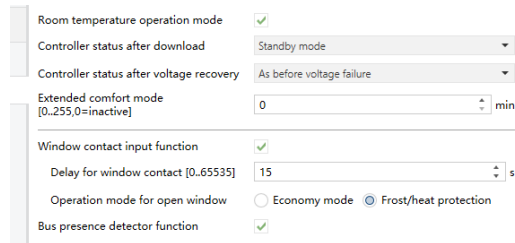

Figure 3.16

**Parameter “Controller status after download”**

Setting status of FCU after download

Options:

- Standby mode
- Economy mode
- Comfort mode

**Parameter “Controller status after voltage recovery”**

Setting status of FCU after voltage recovery

Options:

- Standby mode
- Comfort mode
- Economy mode
- Frost/heat protection
- As before voltage failure

**Parameter “Extended comfort mode**

**[0..255,0=inactive] ”**

Room temperature operation mode Switch to comfort after the time set by this parameter back to the original state.

Options: 0...255, 0= inactive

**Parameter “Setting interface contact input function”**

**Parameter “Delay for setting interface contact**

**[0..65535] ”**

Options: 0...65535

**Parameter “Operation mode for open setting interface”**

Options:

- Economy mode
- Frost/heat protection mode

These three Parameters show on above use to setting for setting interface mode. Enable Parameter “Setting interface contact input function” To use this mode. After time set by Parameter “Delay for setting interface contact [0.65535]” switch to Operation mode set by Parameter “Operation mode for open setting interface”.

**3. PARAMETER SETTING DESCRIPTION IN ETS (continues)**

**Parameter “Bus presence detector function”**

Setting for enable bus presence detector function.

**Parameter “Initial setpoint temperature”**

Setting for the initial setpoint temperature displayed on the screen for FCU power on.

Options: 10.0...35.0

**Parameter “Fan”**

Setting for enable fan function.

**Parameter “Scene”**

Setting for enable Scene function.

**■ 3.9.1. HVAC controller >FCU setting>Setpoint**

Parameter setting interface “Setpoint” shown as Figure3.18, it is mainly for setting related parameters of FCU setpoint, such as Setpoint method. Temperature in comfort/ standby/ economy frost protection mode and so on. Before setting this interface enable “Room temperature operation mode” on the “FCU setting” setting interface.

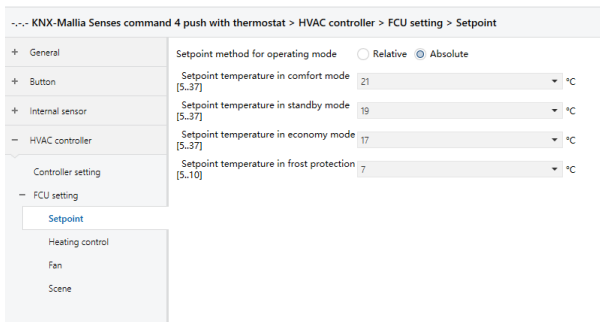

Figure 3.18. HVAC controller >FCU setting > Setpoint Parameter setting interface

**Parameter “Setpoint method for operating mode”**

Setting for Setpoint method for operating mode

Options:

Relative

Absolute

“Setpoint method for operating mode” set as “Relative”. Set the parameters shown as Figure 3.17

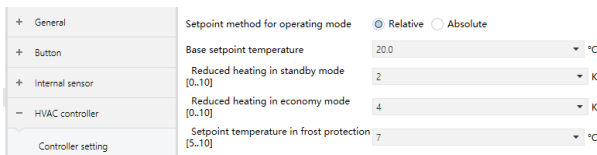

Figure 3.17

**Parameter “ Base setpoint temperature”**

Setting for Base setpoint temperature for comfort mode.

Options: 10.0...35.0

**3. PARAMETER SETTING DESCRIPTION IN ETS (continues)**

**Parameter “ Reduced heating in standby mode [0..10]”**

Setting for the setpoint temperature of standby mode how much less than “Base setpoint temperature”

Options: 0...10

**Parameter “ Reduced heating in economy mode [0..10]”**

Setting for the setpoint temperature of economy mode how much less than “Base setpoint temperature”

Options: 0...10

**Parameter “Setpoint temperature in frost protection mode [5..10]”**

Setting for the setpoint temperature of frost protection mode

Options: 5...10

“Setpoint method for operating mode” set as “Absolute” set the parameters shown as Figure 3.19

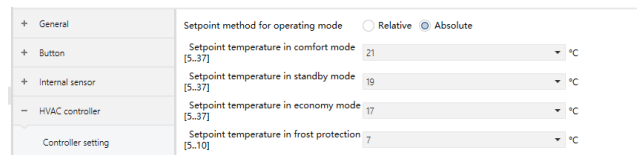

Figure 3.19

**Parameter “Setpoint temperature in comfort mode [5..37]”**

Setting for the setpoint temperature of comfort mode

Options: 5...37

**Parameter “Setpoint temperature in standby mode [5..37]”**

Setting for the setpoint temperature of standby mode

Options: 5...37

**Parameter “Setpoint temperature in economy mode [5..37]”**

Setting for the setpoint temperature of economy mode

Options: 5...37

**Parameter “Setpoint temperature in frost protection mode [5..10]”**

Setting for the setpoint temperature of frost protection mode

Options: 5...10

**■ 3.9.2. HVAC controller >FCU setting> Heating control**

Parameter setting interface “Heating control” shown as Figure3.20, it is mainly for setting related parameters of heating control. Before setting this interface “Room temperature control mode” set as “Heating” on the “FCU

**3. PARAMETER SETTING DESCRIPTION IN ETS (continues)**

setting” setting interface.

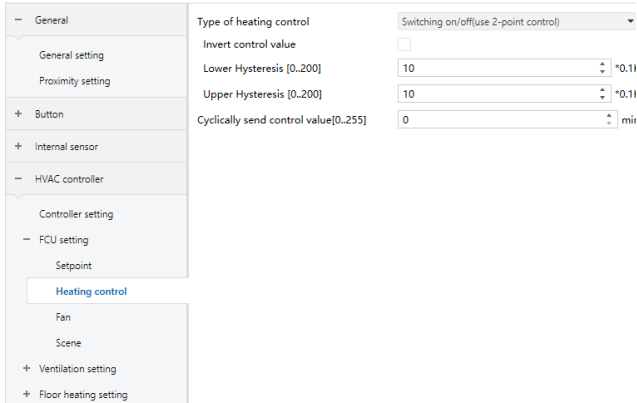

Figure 3.20 HVAC controller >FCU setting> Heating control Parameter setting interface

**Parameter “Type of heating control”**

Setting for heating mode use which type to control.

Options:

- Switching on/off (use 2-point control)
- Switching PWM (use PI control)
- Continuous control (use PI control)

**Parameter “Invert control value”**

Set to enable Invert control value.

Parameter “Type of heating control” set as“Switching on/off(use 2-point control) ”set below:

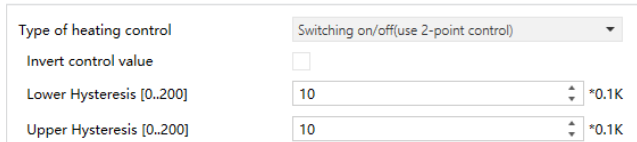

**Parameter “Lower Hysteresis [0..200] ”**

**Parameter “Upper Hysteresis [0..200] ”**

These two parameters for setting the lower/upper hysteresis temperature in HVAC Heating

When the actual temperature(T) > the setting temperature + the upper hysteresis temperature, then will stop heating.

When the actual temperature(T) < the setting temperature - the lower hysteresis temperature, then will start heating.

Options: 0...200

Parameter “Type of heating control” set as“Switching PWM(use PI control) ”set below:

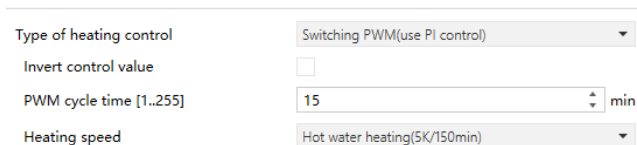

**3. PARAMETER SETTING DESCRIPTION IN ETS (continues)**

**Parameter “PWM cycle time [1..255] ”**

For setting the period of the control object cycle to send the switch value, the object sends the switch value according to the duty cycle of the control value.

Options: 1...255

**Parameter “Heating speed”**

Setting the response speed of the heating PI controller.

Different response speeds apply to different environments.

Options:

- Hot water heating(5K/150min)
- Underfloor heating(5K/240min)
- Electrical heating(4K/100min)
- Split unit(4K/90min)
- Fan coil unit(4K/90min)
- User defined

Parameter “Type of heating control” set as“Continuous control(use PI control)”set below

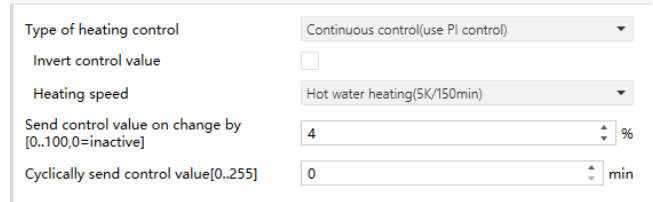

**Parameter “Heating speed”**

Setting the response speed of the heating PI controller.

Different response speeds apply to different environments.

Options:

- Hot water heating(5K/150min)
- Underfloor heating(5K/240min)
- Electrical heating(4K/100min)
- Split unit(4K/90min)
- Fan coil unit(4K/90min)
- User defined.

**Parameter “Send control value on change by [0..100,0=inactive] ”**

This parameter is visible when control type is “Continuous control (use PI control)”, for setting the changing value of the control value to be sent to the bus.

Options: 0...100, 0=inactive

**Parameter “Cyclically send control value[0..255] ”**

Setting the period of cyclically sending control value to the bus.

Options: 0...255



**3. PARAMETER SETTING DESCRIPTION IN ETS (continues)**

**■ 3.9.3. HVAC controller >FCU setting> Cooling control**

Parameter setting interface “Cooling control” shown as Figure3.21, it is mainly for setting related parameters of cooling control. Before setting this interface “Room temperature control mode” set as “Cooling” on the “FCU setting” setting interface.

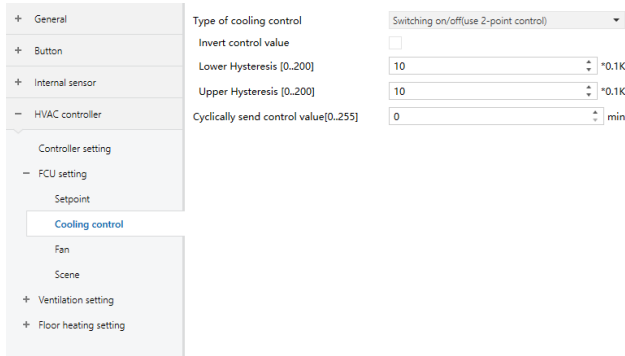

Figure 3. 21.HVAC controller >FCU setting> Cooling control interface

**Parameter “Type of Cooling control”**

Setting for cooling mode use which type to control.

Options:

- Switching on/off (use 2-point control)
- Switching PWM (use PI control)
- Continuous control (use PI control)

**Parameter “Invert control value”**

Set to enable Invert control value.

Parameter “Type of heating control” set as “Switching on/off(use 2-point control) ”set below:

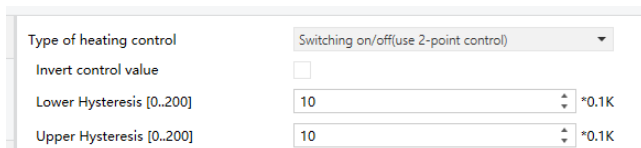

**Parameter “Lower Hysteresis [0..200] ”**

**Parameter “Upper Hysteresis [0..200] ”**

These two parameters for setting the lower/upper hysteresis temperature in HVAC Cooling

When the actual temperature (T) < the setting temperature - the lower hysteresis temperature, then will stop cooling.

When the actual temperature (T) > the setting temperature +the upper hysteresis temperature, then will start cooling.

Options: 0...200

Parameter “Type of heating control” set as” Switching PWM(use PI control)”set below:

**3. PARAMETER SETTING DESCRIPTION IN ETS (continues)**

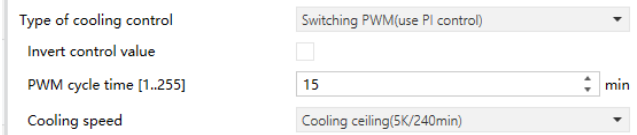

**Parameter “PWM cycle time [1..255] ”**

For setting the period of the control object cycle to send the switch value, the object sends the switch value according to the duty cycle of the control value.

Options: 1...255

**Parameter “ Cooling speed”**

Setting the response speed of the cooling PI controller.

Different response speeds apply to different environments.

Options:

- Cooling ceiling(5K/240min)
- Split unit(4K/90min)
- User defined.
- Fan coil unit(4K/90min)

Parameter “Type of heating control” choose “Continuous control(use PI control)”set below

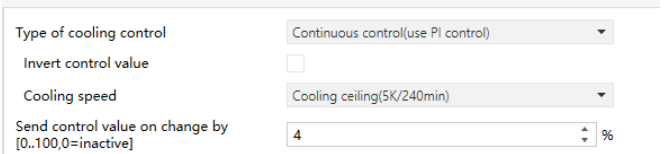

**Parameter “ Cooling speed”**

Setting the response speed of the cooling PI controller.

Different response speeds apply to different environments.

Options:

- Cooling ceiling(5K/240min)
- Split unit(4K/90min)
- User defined.
- Fan coil unit(4K/90min)

**Parameter “Send control value on change by [0..100,0=inactive] ”**

This parameter is visible when control type is “Continuous control (use PI control)”, for setting the changing value of the control value to be sent to the bus.

Options: 0...100, 0=inactive

**Parameter “Cyclically send control value[0..255] ”**

Setting the period of cyclically sending control value to the bus.

Options: 0...255

**3. PARAMETER SETTING DESCRIPTION IN ETS (continues)**

**3.9.4. HVAC controller >FCU setting>Heating /Cooling control**

Parameter setting interface “Heating /Cooling control” shown as Figure3.22, it is mainly for setting related parameters of heating and cooling control. Before setting this interface “Room temperature control mode” set as “Heating /Cooling control” on the “FCU setting” setting interface.

The parameter settings are the same as 3.9.2and3.9.3

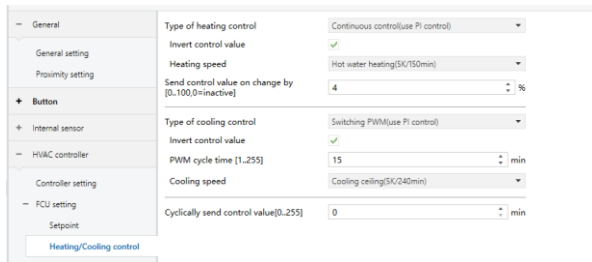

Figure 3.22 HVAC controller >FCU setting> Heating /Cooling control Parameter setting interface

**3.9.5. HVAC controller>FCU setting>Fan**

Parameter setting interface “Fan” of “FCU setting” shown as Figure3.23, it is mainly for setting related parameters of Fan, such as “Output value for Fan speed”. “Status feedback for Fan speed” and so on.

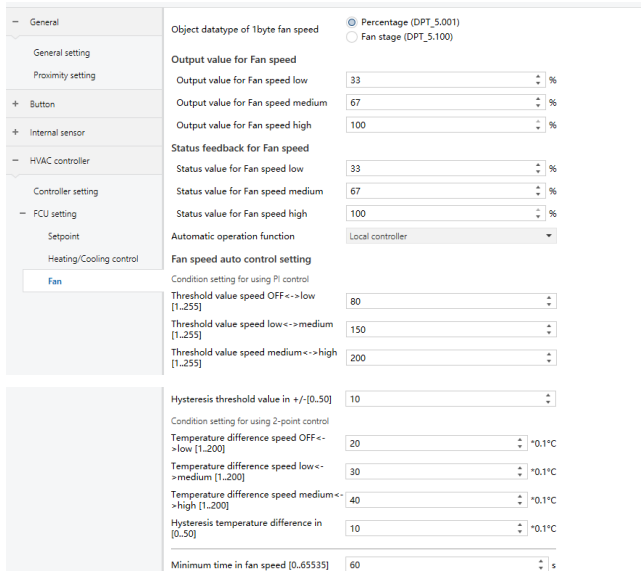

Figure 3.23. HVAC controller>FCU setting>Fan

**Parameter “Object datatype of 1byte fan speed”**

This parameter setting for the object datatype of 1byte fan speed.

**3. PARAMETER SETTING DESCRIPTION IN ETS (continues)**

Options:

- Percentage (DPT 5.001)
- Fan stage (DPT\_5.100)

**Output value for Fan speed**

**Parameter “Output value for Fan speed low”**

**Parameter “Output value for Fan speed medium”**

**Parameter “Output value for Fan speed high”**

These parameters setting the switching value that sent by each fan speed.

Options:

- 1...100(“Object datatype of 1byte fan speed “set as” Percentage (DPT 5.001)”)
- 1...255(“Object datatype of 1byte fan speed “set as” Fan stage (DPT\_5.100)”)

**Status feedback for Fan speed”**

**Parameter “Status value for Fan speed low”**

**Parameter “Status value for Fan speed medium”**

**Parameter “Status value for Fan speed high”**

These parameters are setting for the status feedback value of each fan speed. The device will update and display the fan speed according to the feedback value.

Options:

- 1...100(“Object datatype of 1byte fan speed “set as” Percentage (DPT 5.001)”)
- 1...255(“Object datatype of 1byte fan speed “set as” Fan stage (DPT\_5.100)”)

**Parameter “Automatic operation function”**

Setting for Automatic operation function

Options:

- Disable
- Local controller
- External controller

“Automatic operation function “set as” Local controller”, set below

**Fan speed auto control setting**

**Condition setting for using PI control.**

**Parameter “Threshold value speed OFF<->low [1..255]”**

Define threshold value for off-fan and low-level fan speeds. If the control value is greater than this setting threshold value, low-level fan speed will start running.

Options:1...255

**3. PARAMETER SETTING DESCRIPTION IN ETS (continues)**

**Parameter "Threshold value speed low<->medium [1..255] "**

Define the threshold value for switching the fan speed to medium fan speed.

If the control value is greater than this setting threshold, the medium fan speed will start running.

Options: 1...255

**Parameter "Threshold value speed medium<->high [1..255] "**

Define the threshold for switching the fan speed to high fan speed.

If the control value is greater than this setting threshold, the high fan speed will start running.

Options: 1...255

**Parameter "Hysteresis threshold value in +/-[0..50] "**

Setting the hysteresis value of the threshold value, which can avoid the unnecessary action of the fan when the control value fluctuates near the threshold.

Options: 0..50

**Condition setting for using 2-point control**

**Parameter "Temperature difference speed OFF<>low [1..200] "**

Define the Temperature for off-fan and low-level fan speeds. If the control value is greater than this setting temperature value, low-level fan speed will start running.

Options: 1...200

**Parameter "Temperature difference speed low<>medium [1..200] "**

Define the Temperature for off-fan and low-level fan speeds. If the control value is greater than this setting temperature value, medium fan speed will start running.

Options: 1....200

**Parameter "Temperature difference speed medium< >high [1..200] "**

Define the Temperature for off-fan and low-level fan speeds. If the control value is greater than this setting temperature value, high fan speed will start running.

Options: 1....200

**Parameter "Hysteresis temperature difference in [0..50] "**

Setting the hysteresis value of the temperature value, which can avoid the unnecessary action of the fan when the control value fluctuates near the temperature.

**3. PARAMETER SETTING DESCRIPTION IN ETS (continues)**

Options: 0..50

**Parameter "Minimum time in fan speed [0..65535] "**

Defines the residence time of the fan from the current fan speed to a higher fan speed or lower fan speed, that is, the minimum time for a fan speed operation.

If you need to switch to another fan speed, you need to wait for this period before switching.

If the current fan speed has been running long enough, the fan speed can be changed quickly.

Options: 0..65535

0: there is no minimum running time, but the delay switching time of fan speed still needs to be considered.

**■ 3.9.6. HVAC controller>FCU setting>Scene**

Parameter setting interface "Scene" shown as Figure3.24, it is mainly for setting related parameters of scene control.

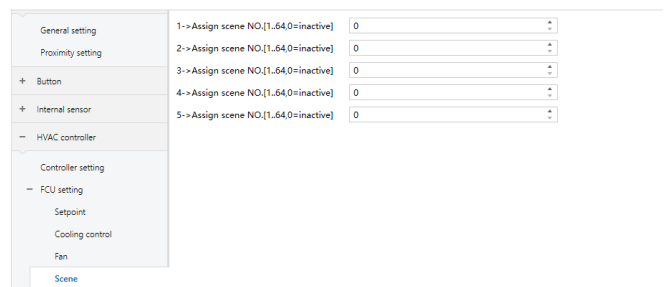

Figure 3.24 HVAC controller > AC setting Parameter setting interface

**Parameter "1->Assign scene NO.[1..64,0=inactive] "**

**Parameter "2->Assign scene NO.[1..64,0=inactive] "**

**Parameter "3->Assign scene NO.[1..64,0=inactive] "**

**Parameter "4->Assign scene NO.[1..64,0=inactive] "**

**Parameter "5->Assign scene NO.[1..64,0=inactive] "**

These parameters setting for the scene number.

Options: 0..64, 0=inactive

When these parameters not zero, set the parameters shown as Figure 3.25

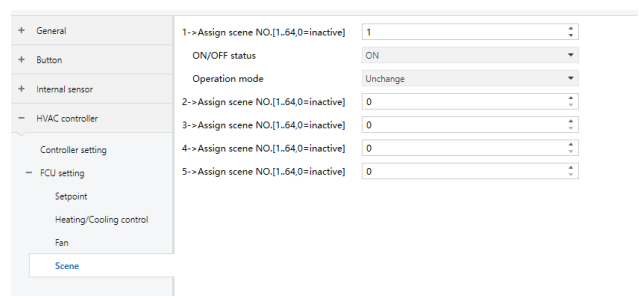

Figure 3.25

**3. PARAMETER SETTING DESCRIPTION IN ETS (continues)**

**Parameter “ON/OFF status”**

This parameter for setting on/off status of FCU, when scene recall.

Options:

- OFF
- ON
- Unchange

**Parameter “Operation mode”**

This parameter for setting operation mode of FCU, when scene recall.

Options:

- Standby mode
- Comfort mode
- Economy mode
- Frost/heat protection
- Unchange

**■ 3.10. HVAC controller>AC setting**

Parameter setting interface “HVAC controller>AC setting” shown as Figure3.26, it is mainly used for setting related parameters of AC setting. Before setting this interface “Room temperature control function as” set as “AC control” on the “Controller setting” setting interface.

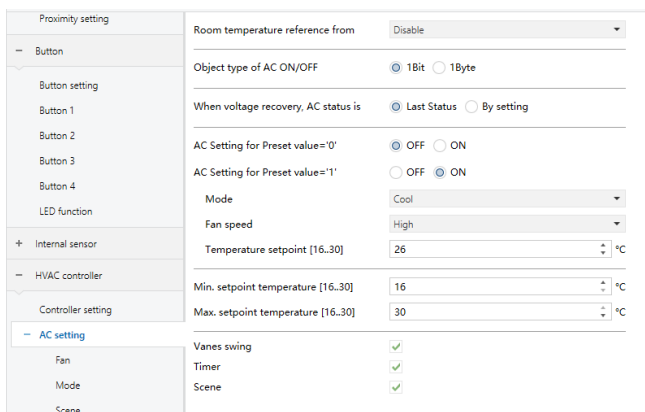

Figure 3.26 HVAC controller > AC setting Parameter setting interface

**Parameter “Room temperature reference from”**

This parameter for setting the resource of the AC function temperature reference.

Options:

- Disable
- FCU control
- AC control

Parameter “Room temperature reference from” set as “AC control”, set parameters shown as Figure 3.27.

**3. PARAMETER SETTING DESCRIPTION IN ETS (continues)**

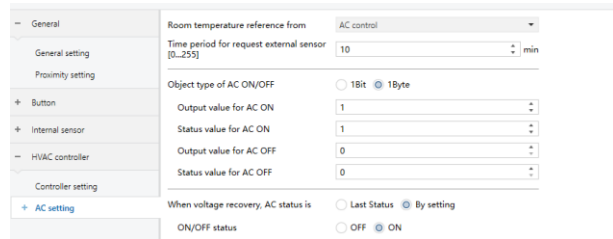

Figure 3.27

**Parameter “Time period for request external sensor [0..255] ”**

This parameter for setting the period for request that the device sends to the external sensor.

Options: 0..255

**Parameter “Object type of AC ON/OFF”**

Setting the object type of AC ON/OFF.

Options:

- 1 Bit
- 1Byte

Parameter “Object type of AC ON/OFF” set as “1Byte”, set parameters shown as Figure 3.28.

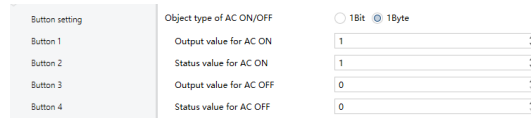

Figure 3.28

**Parameter “Output value for AC ON”**

**Parameter “Status value for AC ON”**

**Parameter “Output value for AC OFF”**

**Parameter “Status value for AC OFF”**

These parameter for setting the output and status value of AC on/off sent to the bus.

Options: 0..255

**Parameter “When bus recovery,AC status is”**

Setting AC status after bus recovery.

Options:

- Last Status
- By setting

Parameter “When bus recovery status is” set as “By setting”, set parameters shown as Figure 3.29.”

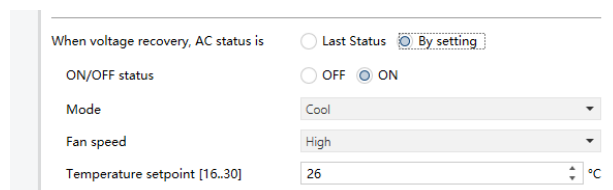

Figure 3.29

**3. PARAMETER SETTING DESCRIPTION IN ETS (continues)****Parameter "ON/OFF status "**

Setting for ON/OFF status of the AC function after the bus recovery

Options:

OFF

ON

Parameter "ON/OFF status "set as" ON", set below:

**Parameter "Mode "**

Setting for mode of the AC function after the bus recovery.

Options:

Auto

Cool

Heat

Dry

Fan

**Parameter "Fan speed "**

Setting for fan speed of the AC function after the bus recovery.

Options:

Auto

Low

Mediu

High

**Parameter "Temperature setpoint [16..30] "**

Setting for temperature setpoint of the AC function after the bus recovery.

Options:16...30

**Parameter "AC Setting for Preset value='0' "**

When receiving the value '0' from the bus through the object "Preset 1Bit, in", call the preset state of the air conditioner controller.

Options:

OFF

ON

Parameter "AC Setting for Preset value='0' "set as"ON ",set below:

**Parameter "Mode"**

Setting for the mode of ac function after the object "Preset 1Bit, in" resive '0'

Options:

Auto

Cool

Heat

**3. PARAMETER SETTING DESCRIPTION IN ETS (continues)**

Dry

Fan

**Parameter "Fan speed"**

Setting for the fan speed level of ac function after the object "Preset 1Bit, in" resive '0'

Options:

Auto

Low

Mediu

High

**Parameter "Temperature setpoint [16..30] "**

Setting for Temperature setpoint of ac function after the object "Preset 1Bit, in" resive '0'.

Options: 16...30

**Parameter "AC Setting for Preset value='1' "**

When receiving the value '1' from the bus through the object "Preset 1Bit, in", call the preset state of the air conditioner controller.

Options:

OFF

ON

Parameter "AC Setting for Preset value='1' "set as" ON ",set below:

**Parameter "Mode"**

Setting for the mode of ac function after the object "Preset 1Bit, in" resive '1':

Auto

Cool

Heat

Dry

Fan

**Parameter "Fan speed"**

Setting for the fan speed level of ac function after the object "Preset 1Bit, in" resive '1'.

Options:

Auto

Low

Mediu

High

**3. PARAMETER SETTING DESCRIPTION IN ETS (continues)**

**Parameter“Temperature setpoint [16..30] ”**

Setting for Temperature setpoint of ac function after the object "Preset 1Bit, in" reside '0'.

Options: 16...30

**Parameter“Min. setpoint temperature [16..30] ”**

**Parameter“Max. setpoint temperature [16..30] ”**

These two parameters setting the adjustment range for limiting the setting temperature. The setting minimum value should be less than the maximum value.

If the setting temperature beyond the range, then output the limited value.

Options: 16...30

**Parameter“Timer”**

This parameter setting whether to enable timer.

**Parameter“Scene”**

This parameter setting whether to enable scene.

**■ 3.10.1. HVAC controller > AC setting > Fan**

Parameter setting interface “ HVAC controller> AC setting>Fan” shown as Figure3.30, it is mainly for setting related parameters of Fan, such as “Output value for Fan speed”. “Status feedback for Fan speed” and so on.

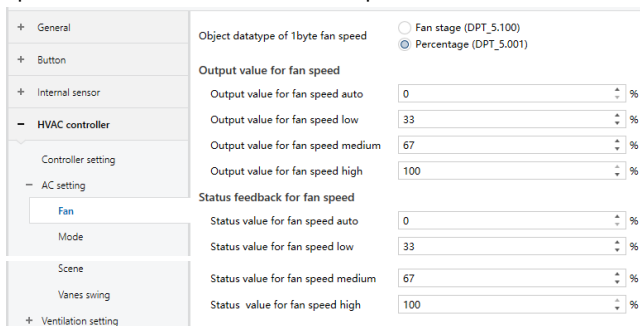

Figure 3.30 HVAC controller > AC setting>Fan Parameter setting interface.

**Parameter“Object datatype of 1 byte fan speed”**

This parameter setting for the object datatype of fan speed.

Options:

Fan stage (DPT\_5.100)

Percentage (DPT 5.001)

**Output value for fan speed**

**Parameter“Output value for fan speed auto”**

**Parameter“Output value for fan speed low”**

**Parameter“Output value for fan speed medium”**

**Parameter“Output value for fan speed high”**

These parameters setting the switching value that sent by each fan speed.

**3. PARAMETER SETTING DESCRIPTION IN ETS (continues)**

Options:

1...100(“Object datatype of 1byte fan speed” set as“ Percentage (DPT 5.001)“)

1...255(“Object datatype of 1byte fan speed “set as“ Fan stage (DPT\_5.100)“)

**Status feedback for fan speed**

**Parameter“Status value for fan speed auto”**

**Parameter“Status value for fan speed low”**

**Parameter“Status value for fan speed medium”**

**Parameter“Status value for fan speed high”**

These parameters are setting for the status feedback value of each fan speed. The device will update and display the fan speed according to the feedback value.

Options:

1...100(“Object datatype of 1byte fan speed” set as“ Percentage (DPT 5.001)“)

1...255(“Object datatype of 1byte fan speed “set as“ Fan stage (DPT\_5.100)“)

**■ 3.10.2. HVAC controller>AC setting>Mode**

Parameter setting interface “HVAC controller>AC setting>Mode” shown as Figure3.31, t is mainly for setting related parameters of each Mode, such as Auto mode output value, Auto mode status value and so on.

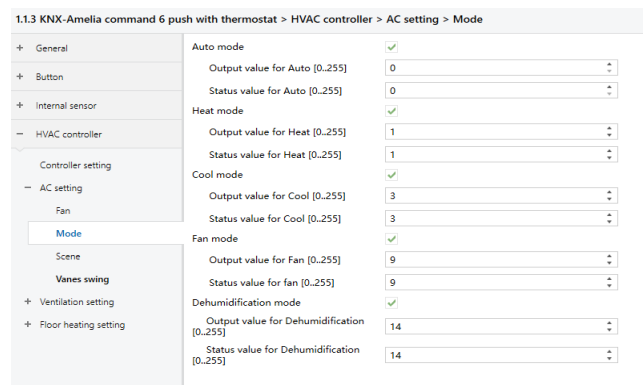

Figure3.31 HVAC controller>AC setting>Mode

**Parameter“Auto mode”**

This parameter for setting whether to enable Auto control mode of Air-conditioner

**Parameter“Output value for Auto [0..255] ”**

This parameter is to define to switch to the value sent by auto mode.

Options: 0...255

**3. PARAMETER SETTING DESCRIPTION IN ETS (continues)**

**Parameter“Status value for Auto [0..255] ”**

Set the status feedback value of auto mode, the device will update the icon status according to the feedback value received.

Options: 0...255

**Parameter“Heat mode”**

This parameter for setting whether to enable Heat mode of Air-conditioner.

**Parameter“Output value for Heat [0..255] ”**

This parameter is to define to switch to the value sent by Heat mode.

Options: 0...255

**Parameter “Status value for Heat [0..255]”**

Set the status feedback value of heating mode. The panel will update the icon status of the mode according to the received feedback value.

Options: 0...255

**Parameter“Cool mode”**

This parameter for setting whether to enable Cool mode of Air-conditioner.

**Parameter“Output value for Cool [0..255] ”**

This parameter is to define to switch to the value sent by Cool mode.

Options: 0... 255

**Parameter “Status value for Cool [0..255]”**

Set the status feedback value of **heating** mode. The panel will update the icon status of the mode according to the received feedback value.

Options: 0...255

**Parameter“Fan mode”**

This parameter for setting whether to enable Fan mode of Air-conditioner.

**Parameter“Output value for Fan [0..255] ”**

This parameter is to define to switch to the value sent by Fan l mode.

Options: 0...255

**Parameter “Status value for fan [0..255]”**

Set the status feedback value of Fan mode. The panel will update the icon status of the mode according to the received feedback value.

Options: 0...255

**3. PARAMETER SETTING DESCRIPTION IN ETS (continues)**

**Parameter“Dehumidification mode”**

This parameter for setting whether to enable Dehumidification mode of Air-conditioner.

**Parameter“Output value for Dehumidification [0..255] ”**

This parameter is to define to switch to the value sent by Dehumidification mode.

Options: 0...255

**Parameter “Status value for Dehumidification [0..255] ”**

Set the status feedback value of Dehumidification mode. The panel will update the icon status of the mode according to the received feedback value.

Options: 0...255

**■ 3.10.3. HVAC controller>AC setting > Scene**

Parameter setting interface “HVAC controller>AC setting>Scene” shown as Figure3.32, it is mainly for setting related parameters of AC scene.

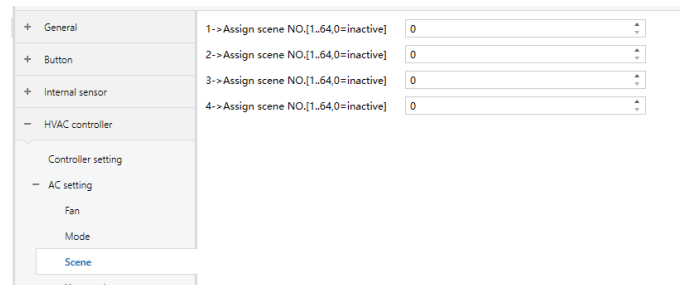

Figure 3.32 HVAC controller > AC setting>Scene Parameter setting interface.

**Parameter“1->Assign scene NO.[1..64,0=inactive]”**

**Parameter“2->Assign scene NO.[1..64,0=inactive]”**

**Parameter“3->Assign scene NO.[1..64,0=inactive]”**

**Parameter“4->Assign scene NO.[1..64,0=inactive]”**

These parameters setting for the scene number.

Options: 1..64, 0 is unavailable

When these parameters not zero,set the parameters shown as Figure 3.33.

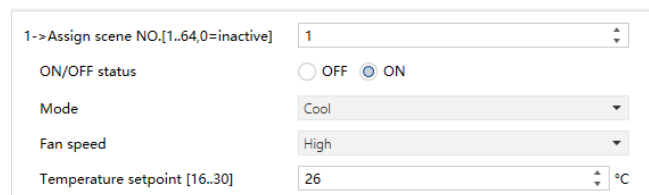

Figure 3.33.

**3. PARAMETER SETTING DESCRIPTION IN ETS (continues)**

**Parameter "ON/OFF status"**

This parameter for setting on/off status of Air-conditioner when scene recall.

Options:

OFF

ON

When set as "ON", the following parameters are visible:

**Parameter "Mode"**

This parameter for setting the mode of Air-conditioner,when scene recall.

Options:

Auto

Cool

Heat

Dry

Fan

**Parameter "Fan speed"**

This parameter for setting fan speed of Air-conditioner,when scene recall.

Options:

Auto

Low

Mediu

High

**Parameter "Temperature setpoint [16..30]"**

This parameter for setting temperature setpoint of Air-conditioner when scene recall.

Options: 16..30

**3.11. HVAC controller > Ventilation setting**

Parameter setting interface "Ventilation setting" shown as Figure 3.34, it is mainly for setting related parameters of Ventilation.

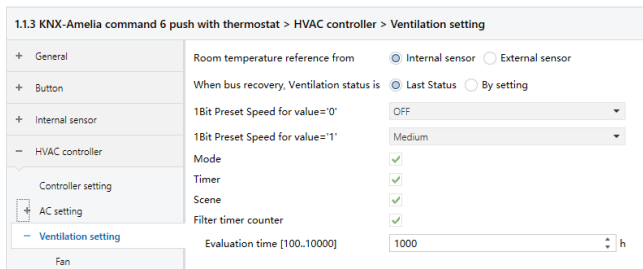

Figure 3.34 HVAC controller > Ventilation setting Parameter setting interface.

**3. PARAMETER SETTING DESCRIPTION IN ETS (continues)**

**Parameter "Room temperature reference from"**

This parameter for setting the resource of the Ventilation function temperature reference

Options:

Internal sensor

External sensor

When parameter "Room temperature reference from" set as "External sensor", set parameters shown as below.

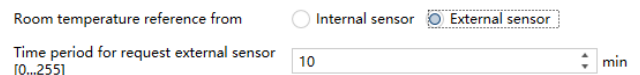

**Parameter "Time period for request external sensor[0..255]"**

This parameter for setting the time period for read request external sensor.

Options: 0..255

**Parameter "When bus recovery, Ventilation status is"**

Setting ventilation status after bus recovery

Options:

Last Status

By setting

When parameter "When bus recovery, Ventilation status is" set as "By setting", set parameters shown as Figure 3.35

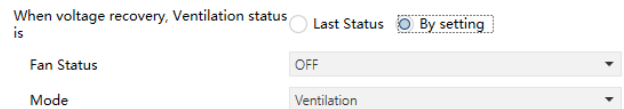

Figure 3.35

**Parameter "Fan Status"**

Setting fan status of ventilation after bus recovery

Options:

OFF

Low

Mediu

High

**Parameter "Mode"**

Setting ventilation mode after bus recovery

Options:

Internal circulation

Air supply

Ventilation



**3. PARAMETER SETTING DESCRIPTION IN ETS (continues)**

**Parameter“1Bit Preset Speed for value= '0' ”**

**Parameter“1Bit Preset Speed for value= '1' ”**

These two parameters setting preset value of fan speed,when receive telegram '0' or '1' from bus.

Options:

- OFF
- Low
- Mediu
- High

**Parameter“Mode ”**

This parameter for setting whether to enable mode control of ventilation.

**Parameter“Timer ”**

This parameter for setting whether to enable timer funtion of ventilation.

**Parameter“Scene ”**

This parameter for setting whether to enable Scene control of ventilation.

**Parameter“Filter timer counter ”**

Setting whether to enable filter timer counter function.

Options:

- Disable
- Enable

When enable, the following parameter is visible.

**Parameter“Evaluation time [100.10000] ”**

Setting the service life of the filter. If the filter takes longer than the setting time, the filter will send an alarm and prompt to clean the filter.

Options: 100...10000

**3. PARAMETER SETTING DESCRIPTION IN ETS (continues)**

**■ 3.11.1. HVAC controller> Ventilation setting>Fan**

Parameter setting interface “Fan” shown as Figure3.36, it is mainly for setting related parameters of Fan. such as “Output value for Fan speed”. “Status feedback for Fan speed” and so on.

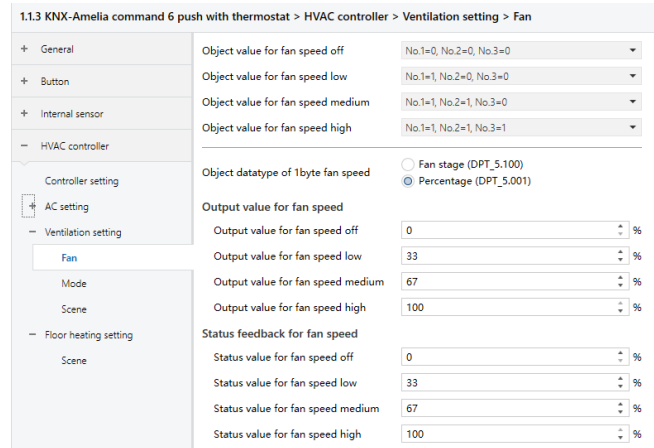

Figure 3.36 HVAC controller > Ventilation setting>Fan Parameter setting interface

**Parameter“Object value for fan speed off ”**

**Parameter“Object value for fan speed low ”**

**Parameter“Object value for fan speed medium ”**

**Parameter“Object value for fan speed high ”**

These parameters defining the switching value sent by each fan speed, the value is sent by three 1bit objects at the same time.

Options:

- No.1=0, No.2=0, No.3=0
- No.1=1, No.2=0, No.3=0
- No.1=0, No.2=1, No.3=0
- No.1=1, No.2=1, No.3=0
- No.1=0, No.2=0, No.3=1
- No.1=1, No.2=0, No.3=1
- No.1=0, No.2=1, No.3=1
- No.1=1, No.2=1, No.3=1

**Parameter“Object datatype of 1byte fan speed”**

This parameter setting for the object datatype of the setpoint:

Options:

- Fan stage (DPT\_5.100)
- Percentage (DPT5.001)

**Output value for fan speed**

**Parameter“Output value for fan speed off ”**

**Parameter“Output value for fan speed low ”**

**3. PARAMETER SETTING DESCRIPTION IN ETS (continues)**

**Parameter“Output value for fan speed medium ”**

**Parameter“Output value for fan speed high ”**

The following parameters setting the output value of each fan speed

Options:

- 0~255(“Object datatype of 1byte fan speed” set as “Fan stage (DPT\_5.100)“)
- 0~100(“Object datatype of 1byte fan speed” set as “Percentage (DPT5.001)“)

**Status feedback for fan speed**

**Parameter“Status value for fan speed off ”**

**Parameter“Status value for fan speed low ”**

**Parameter“Status value for fan speed medium ”**

**Parameter“Status value for fan speed high ”**

The following parameters setting the status value of each fan speed

Options:

- 0~255(“Object datatype of 1byte fan speed” set as “Fan stage (DPT\_5.100)“)
- 0~100(“Object datatype of 1byte fan speed” set as “Percentage (DPT5.001)“)

**■ 3.11.2. HVAC controller > Ventilation setting > Mode**

Parameter setting interface“Mode” of ventilation shown as Figure3.37, it is mainly for setting related parameters of ventilation mode.

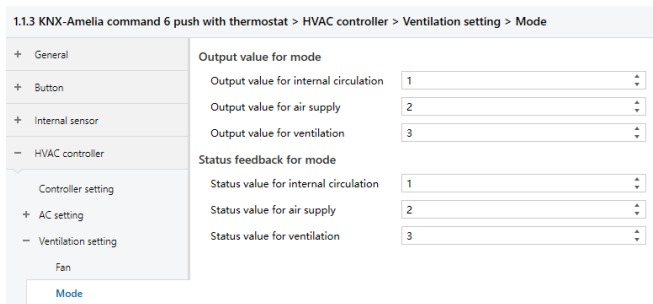

Figure 3.37 HVAC controller > Ventilation setting>Mode Parameter setting interface.

**Output value for mode**

**Parameter“Output value for internal circulation”**

**Parameter“Output value for air supply”**

**Parameter“Output value for ventilation”**

These four parameters for setting the switching value that sent by each mode of Ventilation.

Options: 0...255

**Status feedback for mode**

**3. PARAMETER SETTING DESCRIPTION IN ETS (continues)**

**Parameter“Status value for internal circulation”**

**Parameter“Status value for air supply”**

**Parameter“Status value for ventilation”**

These parameters are used to set the status feedback value from each mode. The screen will update the display content according to the received feedback value.

Options: 0..255

**■ 3.11.3. HVAC controller > Ventilation setting > Scene**

Parameter setting interface“Scene” of Ventilation shown as Figure3.38, it is mainly for setting related parameters of Ventilation scene.

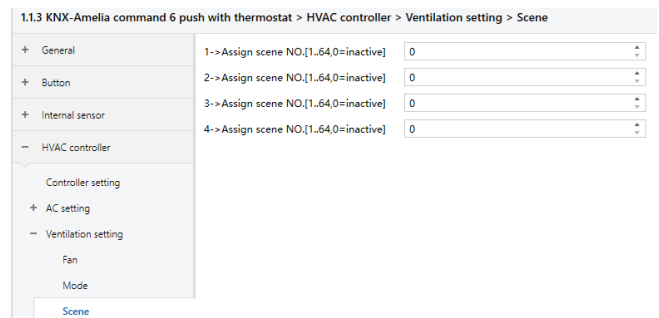

Figure 3.38 HVAC controller > Ventilation setting>Scene Parameter setting interface.

**Parameter“1->Assign scene NO.[1..64,0=inactive] ”**

**Parameter“2->Assign scene NO.[1..64,0=inactive] ”**

**Parameter“3->Assign scene NO.[1..64,0=inactive] ”**

**Parameter“4->Assign scene NO.[1..64,0=inactive] ”**

These parameters for setting the scene number.

Options: 1..64, 0 is unavailable

When these parameters not zero, set the parameters shown as Figure 3.39.

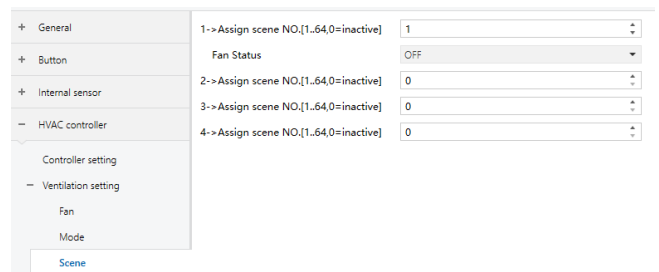

Figure 3.39

**3. PARAMETER SETTING DESCRIPTION IN ETS (continues)**

**Parameter “Fan Status”**

This parameter for setting fan speed of Air-conditioner,when scene recall.

Options:

- OFF
- Low
- Medium
- High

**■ 3.12. HVAC controller>Floor heating setting**

Parameter setting interface “Floor heating setting” shown as Figure3.40, it is mainly for setting related parameters of Floor heating.

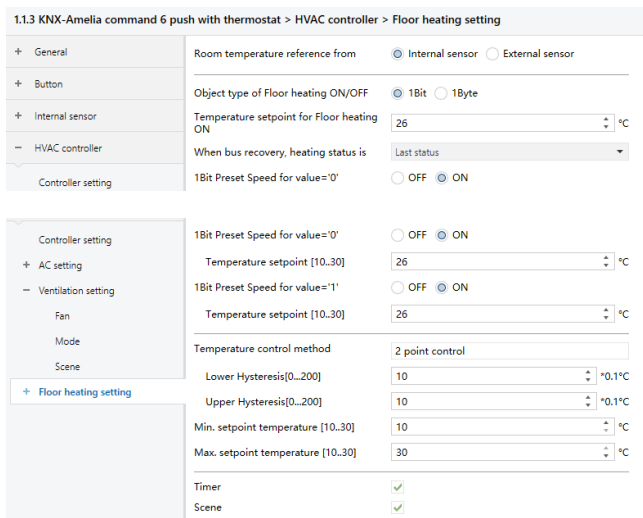

Figure 3.40 HVAC controller > Floor heating setting Parameter setting interface.

**Parameter “Room temperature reference from”**

Setting room temperature of FCU from external or internal sensor detection.

Options:

- Internal sensor
- External sensor

When parameter “Room temperature reference from” set as “External sensor ” ,set parameters shown as below.

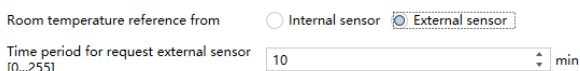

**Parameter “Time period for request external sensor[0..255] ”**

This parameter for setting the time period for read request external sensor.

Options: 0...255

**3. PARAMETER SETTING DESCRIPTION IN ETS (continues)**

**Parameter “Object type of Floor heating ON/OFF”**

This parameter for setting the object type of Floor heating to the bus when Floor heating ON/OFF

Options:

- 1 Bit
- 1Byte

When parameter “Object type of Floor heating ON/OFF” set as “1Byte”, set parameters shown as below.

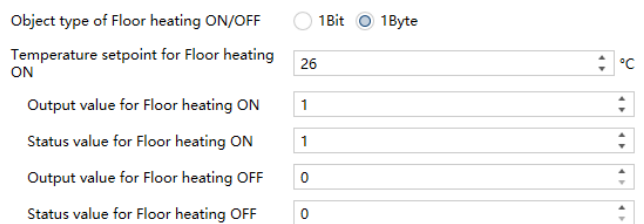

**Parameter “Output value for Floor heating ON”**

**Parameter “Status value for Floor heating ON”**

**Parameter “Output value for Floor heating OFF”**

**Parameter “Status value for Floor heating OFF”**

These parameters for setting the output and feckback value of Floor heating ON/OFF.

Options: 0...255

**Parameter “When bus recovery, heating status is”**

This parameter for setting heating status of floor heating after bus recovery.

Options:

- OFF
- ON
- Last status

Parameter “When bus recovery, heating status is” set as “ON”, set parameters shown as below.

**Parameter “Temperature setpoint [10..30] ”**

Setting temperature setpoint for after bus recovery.

**Parameter “1Bit Preset Speed for value='0'”**

Options:

- OFF
- ON

**Parameter “Temperature setpoint [10.. 30] ”**

Options: 10...30

**3. PARAMETER SETTING DESCRIPTION IN ETS (continues)**

**Parameter“1Bit Preset Speed for value='1'”**

Options:

OFF

ON

**Parameter“Temperature setpoint [10.. 30] ”**

Options: 10...30

1Bit Preset Speed for value='0'  OFF  ON

Temperature setpoint [10..30]  °C

1Bit Preset Speed for value='1'  OFF  ON

Temperature setpoint [10..30]  °C

These four parameters setting preset value of temperature setpoint,when receive telegram '0' or '1' from bus.

Options: 10...30

**Temperature control method--2 point control**

**Parameter“Lower Hysteresis[0.. 200] ”**

**Parameter“Upper Hysteresis [0..200] ”**

These two parameters for setting the lower/upper hysteresis temperature in Floor heating.

When the actual temperature(T) > the setting temperature + the upper hysteresis temperature, then will stop heating;

When the actual temperature(T) < the setting temperature - the lower hysteresis temperature, then will start heating.

Options: 0...200

**Parameter“Min. setpoint temperature [10..30] ”**

**Parameter“Max. setpoint temperature [10..30] ”**

These two parameters setting the adjustment range for limiting the setting temperature. The setting minimum value should be less than the maximum value.

If the setting temperature beyond the range, then output the limited value.

Options: 10...30

**Parameter“Timer”**

This parameter for setting whether to enable timer funtion of Floor heating

**Parameter“Scene”**

This parameter for setting whether to enable Scene control of Floor heating.

**3. PARAMETER SETTING DESCRIPTION IN ETS (continues)**

**■ 3.12.1. HVAC controller>Floor heating setting > Scene**

Parameter setting interface “Scene” of “ Floor heating setting” shown as Figure3.41, it is mainly for setting related parameters of Floor heating scene.

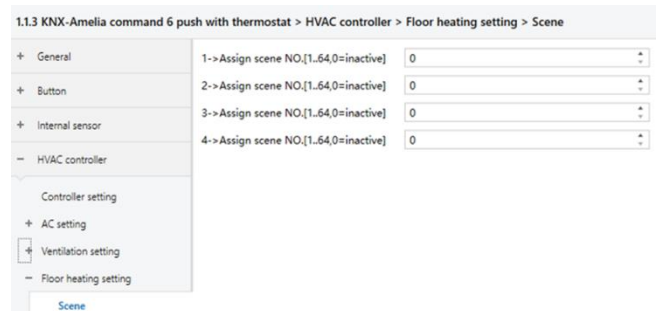

Figure 3.41 HVAC controller > Floor heating setting>Scene Parameter setting interface.

**Parameter“1->Assign scene NO.[1..64,0=inactive] ”**

**Parameter“2->Assign scene NO.[1..64,0=inactive] ”**

**Parameter“3->Assign scene NO.[1..64,0=inactive] ”**

**Parameter“4->Assign scene NO.[1..64,0=inactive] ”**

These parameters for setting the scene number.

Options:1...64, 0 is unavailable

When these parameters not zero, set the parameters shown as Figure 3.42.

1->Assign scene NO.[1..64,0=inactive]

ON/OFF status  OFF  ON

Temperature setpoint [10..30]  °C

Figure 3.42.

**Parameter“ON/OFF status”**

This parameter for setting ON/OFF status of Floor heating when scene recall.

Options:

OFF

ON

When these parameters set as “ON”, set the parameters shown as below.

1->Assign scene NO.[1..64,0=inactive]

ON/OFF status  OFF  ON

Temperature setpoint [10..30]  °C

**Parameter “ Temperature setpoint[10..30]”**

This parameter for setting Temperature setpoint of Floor heating when scene recall.

Options: 10...30

**4. COMMUNICATION OBJECT**

The communication object is the medium to communicate other device on the bus, namely only the communication object can communicate with the bus.

**NOTE:** "C" in "Flag" column in the below table means enable the communication function of the object; "W" means value of object can be written from the bus; "R" means the value of the object can be read by the other devices; "T" means the object has the transmission function; "U" means the value of the object can be updated

■ **4.1. "General" communication object**

	Name ^	Number	Object Function	Group Address	Length	C	R	W	T	U	Data Type	Priority
🔌	General	36	Day/Night		1 bit	C	-	W	-	-	day/night	Low
🔌	General	37	Screen locking		1 bit	C	-	W	-	-	enable	Low

Figure 4.1 General Communication object

NO	Function	Name	Data length	Attribute	Data type DPT
36	Day/Night	General	1bit	C, W	day/night
This communication object is used to receive the status value of day/night status from the bus. Telegram value: Day Night					
37	Screen locking	General	1bit	C, W	enable
This communication object is used to receive telegram value from bus to lock the screen of device. Telegram value: Disable Enable					

Table 4.1 "General" Communication object table

■ **4.2. "Proximity function" Communication object**

	Name	Number ^	Object Function	Group Address	Length	C	R	W	T	U	Data Type	Priority
🔌	Proximity function	33	Dis/En Proximity function	5123	1 bit	C	-	W	-	-	enable	Low
🔌	Proximity function	34	Proximity input	5124	1 bit	C	-	W	-	-	switch	Low
🔌	Proximity function	35	Proximity output	5126	1 byte	C	-	-	T	-	scene number	Low

Figure 4.2 "Proximity function" communication object

NO.	Function	Name	Data length	Attribute	Data type DPT
33	Dis/En Proximity function	Proximity function	1bit	C, W	enable
This communication object is used to receive telegram value from bus to disable or enable proximity function. Telegram value: Disable Enable					
34	Proximity input	Proximity function	1bit	C, W	switch
This communication object is used to receive the status value of proximity function from the bus. Telegram value: ON OFF					
35	Proximity output	Proximity function	1bit/ 1 byte	C, T	Witch scene number

**4. COMMUNICATION OBJECT (continues)**

This communication object is used to send telegram value to bus after promoting to device.  
 The telegram value can be set by parameter " Object type of output value"and " Output value " together.  
 Telegram value:  
 Disable  
 Enable  
 Or  
 Scene NO.1.....Scene NO.64

Table 4.2 "Proximity function" communication objects

**4.3. "Button X- Switch" communication objects**

	Name	Number ^	Object Function	Group Address	Length	C	R	W	T	U	Data Type	Priority
■	Button 1	1	Short/Close, Swtich		1 bit	C	-	W	T	-	switch	Low
■	Button 1	2	Long/Open, Swtich		1 bit	C	-	W	T	-	switch	Low
■	Button 1	3	Disable		1 bit	C	-	W	-	-	enable	Low
■	Button 2	4	Short/Close, Swtich		1 bit	C	-	W	T	-	switch	Low
■	Button 2	5	Long/Open, Swtich		1 bit	C	-	W	T	-	switch	Low
■	Button 2	6	Disable		1 bit	C	-	W	-	-	enable	Low
■	Button 3	7	Short/Close, Swtich		1 bit	C	-	W	T	-	switch	Low
■	Button 3	8	Long/Open, Swtich		1 bit	C	-	W	T	-	switch	Low
■	Button 3	9	Disable		1 bit	C	-	W	-	-	enable	Low
■	Button 4	10	Short/Close, Swtich		1 bit	C	-	W	T	-	switch	Low
■	Button 4	11	Long/Open, Swtich		1 bit	C	-	W	T	-	switch	Low
■	Button 4	12	Disable		1 bit	C	-	W	-	-	enable	Low
■	Button 5	13	Short/Close, Swtich		1 bit	C	-	W	T	-	switch	Low
■	Button 5	14	Long/Open, Swtich		1 bit	C	-	W	T	-	switch	Low
■	Button 5	15	Disable		1 bit	C	-	W	-	-	enable	Low
■	Button 6	16	Short/Close, Swtich		1 bit	C	-	W	T	-	switch	Low
■	Button 6	17	Long/Open, Swtich		1 bit	C	-	W	T	-	switch	Low
■	Button 6	18	Disable		1 bit	C	-	W	-	-	enable	Low
■	Button 7	19	Short/Close, Swtich		1 bit	C	-	W	T	-	switch	Low
■	Button 7	20	Long/Open, Swtich		1 bit	C	-	W	T	-	switch	Low
■	Button 7	21	Disable		1 bit	C	-	W	-	-	enable	Low
■	Button 8	22	Short/Close, Swtich		1 bit	C	-	W	T	-	switch	Low
■	Button 8	23	Long/Open, Swtich		1 bit	C	-	W	T	-	switch	Low
■	Button 8	24	Disable		1 bit	C	-	W	-	-	enable	Low

Figure 4.3 " Button X- Switch " communication object

NO.	Function	Name	Data length	Attribute	Data type DPT
1/4/7/10/13/16/19/22	Short/Close, Switch	Button X	1bit	C, W, T	switch
This communication is used to send telegram value to bus after short press on button. It also can be used to receive telegram value from bus to change Button status. The telegram value can be set by parameter "Reaction on short operation or closing the contact." Telegram value: ON OFF					
2/5/8/11/14/17/20/23	Long/Open, Switch	Button X	1bit	C, W, T	switch
This communication is used to send telegram value to bus after long press on button. It also can be used to receive telegram value from bus to change Button status. The telegram value can be set by the parameter "Reaction on long operation or closing the contact". Telegram value: ON OFF					

4. COMMUNICATION OBJECT (continues)					
3/6/9/12/14/18/21/24	Disable	Button X	1bit	C, W	enable
This communication is used to receive telegram value from bus to enable or disable button function. telegram value is set by the parameter "Trigger value of disable object". Telegram value: Disable Enable					

Table 4.3" Button X- Switch " communication object

■ 4.4. "Button X-Dimming" communication objects

	Name	Number ^	Object Function	Group Address	Length	C	R	W	T	U	Data Type	Priority
■	Button 1	1	Short, Switch		1 bit	C	-	W	T	-	switch	Low
■	Button 1	2	Long, Dimming		4 bit	C	-	W	T	-	dimming control	Low
■	Button 1	3	Disable		1 bit	C	-	W	-	-	enable	Low
■	Button 2	4	Short, Switch		1 bit	C	-	W	T	-	switch	Low
■	Button 2	5	Long, Dimming		4 bit	C	-	W	T	-	dimming control	Low
■	Button 2	6	Disable		1 bit	C	-	W	-	-	enable	Low
■	Button 3	7	Short, Switch		1 bit	C	-	W	T	-	switch	Low
■	Button 3	8	Long, Dimming		4 bit	C	-	W	T	-	dimming control	Low
■	Button 3	9	Disable		1 bit	C	-	W	-	-	enable	Low
■	Button 4	10	Short, Switch		1 bit	C	-	W	T	-	switch	Low
■	Button 4	11	Long, Dimming		4 bit	C	-	W	T	-	dimming control	Low
■	Button 4	12	Disable		1 bit	C	-	W	-	-	enable	Low
■	Button 5	13	Short, Switch		1 bit	C	-	W	T	-	switch	Low
■	Button 5	14	Long, Dimming		4 bit	C	-	W	T	-	dimming control	Low
■	Button 5	15	Disable		1 bit	C	-	W	-	-	enable	Low
■	Button 6	16	Short, Switch		1 bit	C	-	W	T	-	switch	Low
■	Button 6	17	Long, Dimming		4 bit	C	-	W	T	-	dimming control	Low
■	Button 6	18	Disable		1 bit	C	-	W	-	-	enable	Low
■	Button 7	19	Short, Switch		1 bit	C	-	W	T	-	switch	Low
■	Button 7	20	Long, Dimming		4 bit	C	-	W	T	-	dimming control	Low
■	Button 7	21	Disable		1 bit	C	-	W	-	-	enable	Low
■	Button 8	22	Short, Switch		1 bit	C	-	W	T	-	switch	Low
■	Button 8	23	Long, Dimming		4 bit	C	-	W	T	-	dimming control	Low
■	Button 8	24	Disable		1 bit	C	-	W	-	-	enable	Low

Figure 4.4 " Button X-Dimming " communication object

NO.	Function	Name	Data length	Attribute	Data type DPT
1/4/7/10/13/16 /19/22	Short, Switch	Button X	1bit	C, W, T	switch
This communication is used to send telegram value to bus after short press on button. It also can be used to receive telegram value from bus to change Button status. The telegram value can be set by parameter "Reaction on short operation or closing the contact." Telegram value: ON OFF					
2/5/8/11/14/17/ 20/23	Long, Dimming	Button X	4bit	C, W, T	dimming control
The communication object is used to send telegram value of dimming to bus after long press on button. It also can use for receiving telegram value from bus to change dimming status. The telegram value can be set by parameter "Reaction " on long operation or closing the contact." And parameter "Dimming mode." together. Telegram value: Decrease, Break, Decrease, 100 %, Decrease, 50 %... Decrease, 1%, Increase, 1%... Increase, 50 %, Increase, 100 %, Increase, Break					

Table 4.4"Button X-Dimming" communication object

**4. COMMUNICATION OBJECT (continues)**

**■ 4.5. "Button X-Blind" communication object**

	Name	Number ^	Object Function	Group Address	Length	C	R	W	T	U	Data Type	Priorit
■	Button 1	1	Up/Down, Blind		1 bit	C	-	-	T	-	up/down	Low
■	Button 1	2	Stop/Adjust, Blind		1 bit	C	-	-	T	-	step	Low
■	Button 1	3	Disable		1 bit	C	-	W	-	-	enable	Low
■	Button 2	4	Up/Down, Blind		1 bit	C	-	-	T	-	up/down	Low
■	Button 2	5	Stop/Adjust, Blind		1 bit	C	-	-	T	-	step	Low
■	Button 2	6	Disable		1 bit	C	-	W	-	-	enable	Low
■	Button 3	7	Up/Down, Blind		1 bit	C	-	-	T	-	up/down	Low
■	Button 3	8	Stop/Adjust, Blind		1 bit	C	-	-	T	-	step	Low
■	Button 3	9	Disable		1 bit	C	-	W	-	-	enable	Low
■	Button 4	10	Up/Down, Blind		1 bit	C	-	-	T	-	up/down	Low
■	Button 4	11	Stop/Adjust, Blind		1 bit	C	-	-	T	-	step	Low
■	Button 4	12	Disable		1 bit	C	-	W	-	-	enable	Low
■	Button 5	13	Up/Down, Blind		1 bit	C	-	-	T	-	up/down	Low
■	Button 5	14	Stop/Adjust, Blind		1 bit	C	-	-	T	-	step	Low
■	Button 5	15	Disable		1 bit	C	-	W	-	-	enable	Low
■	Button 6	16	Up/Down, Blind		1 bit	C	-	-	T	-	up/down	Low
■	Button 6	17	Stop/Adjust, Blind		1 bit	C	-	-	T	-	step	Low
■	Button 6	18	Disable		1 bit	C	-	W	-	-	enable	Low
■	Button 7	19	Up/Down, Blind		1 bit	C	-	-	T	-	up/down	Low
■	Button 7	20	Stop/Adjust, Blind		1 bit	C	-	-	T	-	step	Low
■	Button 7	21	Disable		1 bit	C	-	W	-	-	enable	Low
■	Button 8	22	Up/Down, Blind		1 bit	C	-	-	T	-	up/down	Low
■	Button 8	23	Stop/Adjust, Blind		1 bit	C	-	-	T	-	step	Low
■	Button 8	24	Disable		1 bit	C	-	W	-	-	enable	Low

Figure 4.5 "Button X-Blind" communication object

NO.	Function	Name	Data length	Attribute	Data type DPT
1/4/7/10/13/16/19/22	Up/Down, Blind	Button X	1bit	C, T	up/down
The communication object is used to send telegram value of blind to bus after short press on button. The telegram value can be set by parameter "Reaction on short operation or closing the contact." And parameter "Dimming mode." together. Telegram value: UP Down					
2/5/8/11/14/17/20/23	Stop/Adjust, Blind	Button X	1bit	C, T	step
The communication object is used to send telegram value of blind to bus after long press on button. The telegram value can be set by parameter "Reaction on long operation or closing the contact." And parameter "Dimming mode." together. Telegram value: Decrease Increase					

Table 4.5 "Button X-Blind" communication object



4. COMMUNICATION OBJECT (continues)

■ 4.6. "Button X-Value output" communication objects

	Name	Number ^	Object Function	Group Address	Length	C	R	W	T	U	Data Type	Priority
■	Button 1	1	Short/Close, Value		1 bit	C	-	-	T	-	switch	Low
■	Button 1	2	Long/Open, Value		2 bytes	C	-	-	T	-	pulses	Low
■	Button 1	3	Disable	6146	1 bit	C	-	W	-	-	enable	Low
■	Button 2	4	Short/Close, Value		1 bit	C	-	-	T	-	switch	Low
■	Button 2	5	Long/Open, Value		2 bytes	C	-	-	T	-	pulses	Low
■	Button 2	6	Disable		1 bit	C	-	W	-	-	enable	Low
■	Button 3	7	Short/Close, Value		1 bit	C	-	-	T	-	switch	Low
■	Button 3	8	Long/Open, Value		2 bytes	C	-	-	T	-	pulses	Low
■	Button 3	9	Disable		1 bit	C	-	W	-	-	enable	Low
■	Button 4	10	Short/Close, Value		1 bit	C	-	-	T	-	switch	Low
■	Button 4	11	Long/Open, Value		2 bytes	C	-	-	T	-	pulses	Low
■	Button 4	12	Disable		1 bit	C	-	W	-	-	enable	Low
■	Button 5	13	Short/Close, Value		1 bit	C	-	-	T	-	switch	Low
■	Button 5	14	Long/Open, Value		2 bytes	C	-	-	T	-	pulses	Low
■	Button 5	15	Disable		1 bit	C	-	W	-	-	enable	Low
■	Button 6	16	Short/Close, Value		1 bit	C	-	-	T	-	switch	Low
■	Button 6	17	Long/Open, Value		2 bytes	C	-	-	T	-	pulses	Low
■	Button 6	18	Disable		1 bit	C	-	W	-	-	enable	Low
■	Button 7	19	Short/Close, Value		1 bit	C	-	-	T	-	switch	Low
■	Button 7	20	Long/Open, Value		2 bytes	C	-	-	T	-	pulses	Low
■	Button 7	21	Disable		1 bit	C	-	W	-	-	enable	Low
■	Button 8	22	Short/Close, Value		1 bit	C	-	-	T	-	switch	Low
■	Button 8	23	Long/Open, Value		2 bytes	C	-	-	T	-	pulses	Low
■	Button 8	24	Disable		1 bit	C	-	W	-	-	enable	Low

Figure 4.6. " Button X-Value output" communication objects

NO.	Function	Name	Data length	Attribute	Data type DPT
1/4/7/10/13/16/19/22	Shor/Close, Value	Button X	1 bit 4 bit 1 byte 2 byte	C, T	switch dimming control counter pulses (0..255) pulses
<p>This communication object is used to send telegram value to bus after short press on button.                      The telegram value can be set by parameter "Reaction on short operation or closing the contact." And parameter "Output value [0...XX]." together. Telegram value:</p> <p>OFF/ON                      Or 0...15                      Or 0...255                      Or 0...65535</p>					
2/5/8/11/14/17/20/23	Long/Open, Value	Button X	1 bit 4 bit 1 byte 2 byte	C, T	switch dimming control counter pulses (0..255) pulses
<p>This communication object is used to send telegram value to bus after long press on button.                      The telegram value can be set by parameter "Reaction on long operation or closing the contact." And parameter "Output value [0...XX]." together. Telegram value:</p> <p>OFF/ON                      Or 0...15                      Or 0...255                      Or 0...65535</p>					

Table 4.6."Button X-Value output"communication objects

**4. COMMUNICATION OBJECT (continues)**

**■ 4.7. "Button X-Scene control" communication object**

	Name	Number ^	Object Function	Group Address	Length	C	R	W	T	U	Data Type	Priority
■	Button 1	1	Short/Close, Scene		1 byte	C	-	-	T	-	scene number	Low
■	Button 1	2	Long/Open, Scene		1 byte	C	-	-	T	-	scene number	Low
■	Button 1	3	Disable		1 bit	C	-	W	-	-	enable	Low
■	Button 2	4	Short/Close, Scene		1 byte	C	-	-	T	-	scene number	Low
■	Button 2	5	Long/Open, Scene		1 byte	C	-	-	T	-	scene number	Low
■	Button 2	6	Disable		1 bit	C	-	W	-	-	enable	Low
■	Button 3	7	Short/Close, Scene		1 byte	C	-	-	T	-	scene number	Low
■	Button 3	8	Long/Open, Scene		1 byte	C	-	-	T	-	scene number	Low
■	Button 3	9	Disable		1 bit	C	-	W	-	-	enable	Low
■	Button 4	10	Short/Close, Scene		1 byte	C	-	-	T	-	scene number	Low
■	Button 4	11	Long/Open, Scene		1 byte	C	-	-	T	-	scene number	Low
■	Button 4	12	Disable		1 bit	C	-	W	-	-	enable	Low
■	Button 5	13	Short/Close, Scene		1 byte	C	-	-	T	-	scene number	Low
■	Button 5	14	Long/Open, Scene		1 byte	C	-	-	T	-	scene number	Low
■	Button 5	15	Disable		1 bit	C	-	W	-	-	enable	Low
■	Button 6	16	Short/Close, Scene		1 byte	C	-	-	T	-	scene number	Low
■	Button 6	17	Long/Open, Scene		1 byte	C	-	-	T	-	scene number	Low
■	Button 6	18	Disable		1 bit	C	-	W	-	-	enable	Low
■	Button 7	19	Short/Close, Scene		1 byte	C	-	-	T	-	scene number	Low
■	Button 7	20	Long/Open, Scene		1 byte	C	-	-	T	-	scene number	Low
■	Button 7	21	Disable		1 bit	C	-	W	-	-	enable	Low
■	Button 8	22	Short/Close, Scene		1 byte	C	-	-	T	-	scene number	Low
■	Button 8	23	Long/Open, Scene		1 byte	C	-	-	T	-	scene number	Low
■	Button 8	24	Disable		1 bit	C	-	W	-	-	enable	Low

NO.	Function	Name	Data length	Attribute	Data type DPT
1/4/7/10/13/16/19/22	Short/Close, Scene	Button X	1Byte	C, T	scene number
This communication object is used to send control telegram to recall or store scene NO.X after short press on the button. Telegram value: Scene NO.1 Scene NO.2 ... Scene NO.63 Scene NO.64					
2/5/8/11/14/17/20/23	Long/Open, Scene	Button X	1Byte	C, T	scene number
This communication object is used to send control telegram to recall or store scene NO.X after long press on the button. Telegram value: Scene NO.1 Scene NO.2 ..... Scene NO.63 Scene NO.64					

**4. COMMUNICATION OBJECT (continues)**

**■ 4.8. "LED X" communication objects**

	Name	Number ^	Object Function	Group Address	Length	C	R	W	T	U	Data Type	Priority
■	LED 1	25	Status		1 bit	C	-	W	T	U	switch	Low
■	LED 2	26	Status		1 bit	C	-	W	T	U	switch	Low
■	LED 3	27	Status		1 bit	C	-	W	T	U	switch	Low
■	LED 4	28	Status		1 bit	C	-	W	T	U	switch	Low
■	LED 5	29	Status		1 bit	C	-	W	T	U	switch	Low
■	LED 6	30	Status		1 bit	C	-	W	T	U	switch	Low
■	LED 7	31	Status		1 bit	C	-	W	T	U	switch	Low
■	LED 8	32	Status		1 bit	C	-	W	T	U	switch	Low

NO.	Function	Name	Data length	Attribute	Data type DPT
25/26/27/28/29/30/31/32	Status	LED X	1bit 1byte	C, W, T, U	switch counter pulses (0..255)

This communication object is used to receive control telegram value of LED status to control led status on device.

It is also used to send telegram value of LED status to bus.

The led status and telegram value are set by parameter "External object datatype.", parameter "When object value is "0",LED is" and parameter "When object value is "1",LED is" together or set by parameter "External object datatype.", parameter "Threshold value is", parameter "If object value<threshold value, LED is", parameter "If object value=threshold value, LED is", and parameter "If object value>threshold value, LED is" together.

Telegram value:

OFF/ON

Or 1...255

**■ 4.9. "Internal sensor" communication object**

	Name	Number ^	Object Function	Group Address	Length	C	R	W	T	U	Data Type	Priority
■	Internal sensor	38	Temperature value		2 bytes	C	R	-	T	-	temperature (°C)	Low

NO.	Function	Name	Data length	Attribute	Data type DPT
38	Temperature value	Internal sensor	2 bytes	C, R, T	temperature (°C)

The communication object is used to send telegram value of temperature detected by the built-in temperature sensor of the device to the bus.

**■ 4.10. "FCU" communication objects**

	Name	Number ^	Object Function	Group Address	Length	C	R	W	T	U	Data Type	Priority
■	FCU	78	ON/OFF status, In		1 bit	C	-	W	-	U	switch	Low
■	FCU	79	External temperature, In		2 bytes	C	-	W	T	U	temperature (°C)	Low
■	FCU	80	Base temperature setpoint, In		2 bytes	C	-	W	-	U	temperature (°C)	Low
■	FCU	82	Operation mode, In		1 byte	C	-	W	-	U	HVAC mode	Low
■	FCU	83	Fan speed, In		1 byte	C	-	W	T	U	percentage (0..100%)	Low
■	FCU	84	Fan automatic operation, In		1 bit	C	-	W	T	U	enable	Low
■	FCU	86	Window contact, In		1 bit	C	-	W	T	U	window/door	Low
■	FCU	87	Presence detector, In		1 bit	C	-	W	T	U	occupancy	Low
■	FCU	89	Scene, In		1 byte	C	-	W	-	-	scene control	Low
■	FCU	90	ON/OFF, Out		1 bit	C	R	-	T	-	switch	Low
■	FCU	92	Current base setpoint temperature, Out		2 bytes	C	-	-	T	-	temperature (°C)	Low
■	FCU	93	Current setpoint adjustment, Out		2 bytes	C	R	-	T	-	temperature (°C)	Low
■	FCU	95	Operation mode, Out		1 byte	C	R	-	T	-	HVAC mode	Low
■	FCU	96	Heating control value, Out		1 bit	C	R	-	T	-	switch	Low
■	FCU	98	Fan speed, Out		1 byte	C	R	-	T	-	percentage (0..100%)	Low
■	FCU	99	Fan Automatic operation, Out		1 bit	C	R	-	T	-	enable	Low

**4. COMMUNICATION OBJECT (continues)**

NO.	Function	Name	Data length	Attribute	Data type DPT
78	ON/OFF status, In	FCU	1 bit	C, W, U	switch
The communication object is used to receive the feedback telegram value of FCU on/off status. Telegram value: ON OFF					
80	Base temperature setpoint, In	FCU	2 bytes	C, W, U	temperature (°C)
This communication object is used to receive telegram value of FCU setpoint temperature from bus, and the setpoint temperature on the device displayed will be updated. Telegram value:10...35					
81	Heating/Cooling mode, In	FCU	1 bit	C, W, U	cooling/heating
The communication object is used to receive telegram value of FCU Heating/Cooling mode status from bus, and the screen will update the icon display according to the received telegram value. Telegram value: Heating Cooling					
82	Operation mode, In	FCU	1byte	C, W, U	HVAC mode
This communication object is used to receive the telegram value of FCU operation mode status. Telegram value: Auto Comfort Standby Economy Building Protection					
83	Fan speed, In	FCU	1 byte	C, W, T, U	percentage (0..100%)
					fan stage (0..255)
This communication object is used to receive the telegram value of FCU fan speed from bus. Telegram value: 0%...100% Or 0...255					
84	Fan automatic operation, In	FCU	1 bit	C, W, T, U	enable
This communication object is used to receive the telegram value of FCU fan automatic operation status from bus. Telegram value: Set Automatic Cancel automatic					
86	Setting interface contact, In	FCU	1bit	C, W, T, U	setting interface/door
This communication object is used to receive the telegram value of FCU Setting interface contact status from bus. Telegram value: Open Close					

<b>4. COMMUNICATION OBJECT (continues)</b>					
87	Presence detector, In	FCU	1 bit	C, W, T, U	occupancy
This communication object is used to receive the telegram value of FCU Presence detector status. Telegram value: Presence detector mode Cancel presence detector mode					
89	Scene, In	FCU	1 byte	C, W	scene control
This communication object is used to recall the scene control of FCU. The parameter is set to the scene No.1~64, and the actual corresponding telegram value is 0~63.					
90	ON/OFF, Out	FCU	1 bit	C, R, T	switch
This communication object is used to send control telegram value of FCU on/off to bus. Telegram value: OFF ON					
91	Current base setpoint temperature, Out	FCU	2 bytes	C, T	temperature (°C)
This communication object is used to send the telegram value of FCU current base setpoint temperature to bus. Telegram value: 10°C...35°C					
92	Current setpoint adjustment, Out	FCU	2 bytes	C, R, T	temperature (°C)
This communication object is used to send telegram value of FCU current setpoint temperature to bus. Telegram value: 10°C...35°C					
93	Heating/Cooling mode, Out	FCU	1bit	C, R, T	cooling/heating
The communication object is used to send control telegram value of FCU Heating/Cooling mode to bus. Telegram value: Heating Cooling					
94	Operation mode, Out	FCU	1 byte	C, R, T	HVAC mode
This communication objects are used to send control telegram value of FCU operation mode to bus. Telegram value: Auto mode Comfort mode Standby mode Economy mode Frost protection/ over-heat protection					
95	Heating control value, Out	FCU	1bit	C, R, T	switch
96	Heating/cooling control value, Out	FCU	1bit	C, R, T	switch
These communication objects are used send control telegram value of FCU Heating or Heating/cooling to bus. Telegram value: Heating Cooling/ Cancel Heating					

4. COMMUNICATION OBJECT (continues)					
97	Cooling control value, Out	FCU	1 byte	C, R, T	percentage (0..100%)
This communication object is used send control telegram value of FCU Heating Cooling to bus. Telegram value: Cooling Cancel Cooling					
98	Fan speed, Out	FCU	1 byte	C, R, T	percentage (0..100%)
This communication is used to send telegram value of FCU fan speed to the bus. Telegram value: 0..100%					
99	Fan Automatic operation, Out	FCU	1 bit	C, R, T	enable
This communication object is used to send the automatic control telegram of FCU fan speed to the bus. Telegram value: Automatic Cancel automatic					

■ 4.11. "AC" communication objects

	Name	Number ^	Object Function	Group Address	Length	C	R	W	T	U	Data Type	Priority
■	AC	39	External temperature, In		2 bytes	C	-	W	T	U	temperature (°C)	Low
■	AC	40	ON/OFF, Out		1 bit	C	-	-	T	-	switch	Low
■	AC	41	ON/OFF Status, In		1 bit	C	-	W	-	-	switch	Low
■	AC	42	Preset 1Bit, In		1 bit	C	-	W	-	-	scene	Low
■	AC	43	Mode, Out		1 byte	C	-	-	T	-	HVAC control mode	Low
■	AC	44	Mode status, In		1 byte	C	-	W	-	-	HVAC control mode	Low
■	AC	45	Fan speed, Out		1 byte	C	-	-	T	-	percentage (0..100%)	Low
■	AC	46	Fan speed status, In		1 byte	C	-	W	-	-	percentage (0..100%)	Low
■	AC	47	Setpoint temperature, Out		2 bytes	C	-	-	T	-	temperature (°C)	Low
■	AC	48	Setpoint temperature, In	6153	2 bytes	C	-	W	-	-	temperature (°C)	Low
■	AC	49	Vanes swing (1-swing,0-stop), Out		1 bit	C	-	-	T	-	start/stop	Low
■	AC	50	Vanes swing (1-swing,0-stop), In		1 bit	C	-	W	-	-	start/stop	Low
■	AC	51	Vanes position 1..4, Out		1 byte	C	-	-	T	-	counter pulses (0..255)	Low
■	AC	52	Vanes position 1..4 status, In		1 byte	C	-	W	-	-	counter pulses (0..255)	Low
■	AC	53	Scene, In		1 byte	C	-	W	-	-	scene number	Low

NO.	Function	Name	Data length	Attribute	Data type DPT
39	External temperature, In	AC	2 bytes	C,W, T, U	temperature (°C)
This communication object is used to receive the temperature value from bus, and the temperature value on the device will be updated.					
40	ON/OFF, Out	AC	1 bit 1byte	C, T	Switch counter pulses (0..255)
This communication object is used to send control telegram value of AC on/off status. Telegram value: ON OFF					
41	ON/OFF Status, In	AC	1 bit 1byte	C, W	Switch counter pulses (0..255)
The communication object is used to receive returning to the preset state command from bus. Telegram value: 0 1					

4. COMMUNICATION OBJECT (continues)					
42	Mode, Out	AC	1 bit	C, W	scene
The communication object is used to receive returning to the preset state command from bus. Telegram value: 0 1					
43	Mode, Out	AC	1 byte	C, T	HVAC control mode
This communication object is used to send the control telegram of AC each mode to bus. Telegram value: Cool Heat Fan only Auto					
44	Mode status, In	AC	1 byte	C, W	HVAC control mode
This communication object is used to receive status feedback of AC each mode. Telegram value: Cool Heat Fan only Auto					
45	Fan speed, Out	AC	1byte	C, T	percentage (0..100%) fan stage (0..255)
This communication object is used to send the control telegram of AC fan speed to bus. Telegram value: 0%...100% Or 0...255					
46	Fan speed status, In	AC	1byte	C, W	percentage (0..100%) fan stage (0..255)
This communication object is used to receive status feedback of AC fan speed status. Telegram value: 0%...100% Or 0...255					
47	Setpoint temperature, Out	AC	2 bytes	C, T	temperature (°C)
This communication object is used to send the control telegram of AC setpoint temperature to bus. Telegram value: 16°C...30°C					
48	Setpoint temperature, In	AC	2 bytes	C, W	temperature (°C)
The communication object is used to receive the temperature setting value from bus, and the temperature setting value on the device will be updated. Telegram value: 16°C...30°C					

**4. COMMUNICATION OBJECT (continues)**

49	Vanes swing (1-swing.0-stop), Out	AC	1 bit	C, T	start/stop
This communication object is used to send the control telegram of AC Vanes swing to bus. Telegram value: Stop Start					
50	Vanes swing (1-swing,0-stop), In	AC	1 bit	C, W	start/stop
This communication object is used to receive status feedback of AC vanes swing. Telegram value: Stop Start					
51	Vanes position 1..4, Out	AC	1 byte	C, T	counter pulses (0..255)
This communication object is used to send the control telegram of AC vanes position to bus. Telegram value: Stop Start					
52	Vanes position 1..4 status, In	AC	1 byte	C, W	counter pulses (0..255)
This communication object is used to receive status feedback of AC vanes position. Telegram value: Stop Start					
53	Scene, In	AC	1 byte	C, W	scene number
This communication object is used to recall the scene control of air conditioning. The parameter is set to the scene No.1~64, and the actual corresponding telegram value is 0~63.					

■ **4.12. "Ventilation" communication object**

	Name	Number ^	Object Function	Group Address	Length	C	R	W	T	U	Data Type	Priority
■	Ventilation	55	ON/OFF, Out		1 bit	C	-	-	T	-	switch	Low
■	Ventilation	56	ON/OFF Status, In		1 bit	C	-	W	-	-	switch	Low
■	Ventilation	57	Fan speed No.1 1Bit, Out		1 bit	C	-	-	T	-	switch	Low
■	Ventilation	58	Fan speed No.2 1Bit, Out		1 bit	C	-	-	T	-	switch	Low
■	Ventilation	59	Fan speed No.3 1Bit, Out		1 bit	C	-	-	T	-	switch	Low
■	Ventilation	60	Fan speed, Out		1 byte	C	-	-	T	-	percentage (0..100%)	Low
■	Ventilation	61	Fan speed status, In		1 byte	C	-	W	-	-	percentage (0..100%)	Low
■	Ventilation	62	Preset 1Bit, In		1 bit	C	-	W	-	-	scene	Low
■	Ventilation	63	Fan mode, Out		1 byte	C	-	-	T	-	counter pulses (0..255)	Low
■	Ventilation	64	Fan mode status, In		1 byte	C	-	W	-	-	counter pulses (0..255)	Low
■	Ventilation	65	Filter alarm, Out		1 bit	C	-	-	T	-	alarm	Low
■	Ventilation	66	Filter timer counter change, In		2 bytes	C	-	W	-	-	time (h)	Low
■	Ventilation	67	Filter timer reset, Out		1 bit	C	-	-	T	-	reset	Low
■	Ventilation	68	Scene, In		1 byte	C	-	W	-	-	scene number	Low



**4. COMMUNICATION OBJECT (continues)**

NO.	Function	Name	Data length	Attribute	Data type DPT
55	ON/OFF, Out	Ventilation	1 bit	C, T	Switch
<p>The communication object is used to send control command of Ventilation on/off status to bus.                      Telegram value:                          ON                          OFF</p>					
56	ON/OFF Status, in	Ventilation	1 bit	C, W	switch
<p>The communication object is used to receive the status feedback value of Ventilation on/off status.                      Telegram value:                          ON                          OFF</p>					
57	Fan speed No.1 1Bit, Out	Ventilation	1 bit	C, T	switch
58	Fan speed No.2 1Bit, Out	Ventilation	1 bit	C, T	switch
59	Fan speed No.3 1Bit, Out	Ventilation	1 bit	C, T	switch
<p>These three communication objects are used to send telegram value to bus at same time.                      These values are used to control fan speed together that set by the parameters shown as below.                      "Object value for fan speed off."                      "Object value for fan speed low"                      "Object value for fan speed medium"                      "Object value for fan speed high"                      Telegram value:                          ON                          OFF</p>					
60	Fan speed, Out	Ventilation	1 byte	C, T	fan stage (0..255)
					percentage (0..100%)
<p>This communication object is used to send the control telegram of Ventilation fan speed to bus.                      Telegram value:                          0%...100%                          Or 0...255</p>					
61	Fan speed status, in	Ventilation	1byte	C, W	fan stage (0..255)
<p>This communication object is used to receive status feedback of Ventilation fan speed.                      Telegram value:                          0%...100%                          Or 0...255</p>					
62	Preset 1Bit, In	Ventilation	1 bit	C, W	scene
<p>The communication object is used to receive returning to the preset state command from bus.                      Telegram value:                          0                          1</p>					

**4. COMMUNICATION OBJECT (continues)**

**■ 4.13. "Floor Heating" communication object**

	Name	Number ^	Object Function	Group Address	Length	C	R	W	T	U	Data Type	Priority
↕	Floor Heating	69	External temperature, In		2 bytes	C	-	W	T	U	temperature (°C)	Low
↕	Floor Heating	70	ON/OFF, Out		1 bit	C	-	-	T	-	switch	Low
↕	Floor Heating	71	ON/OFF status, In		1 bit	C	-	W	-	-	switch	Low
↕	Floor Heating	72	Preset 1Bit, In		1 bit	C	-	W	-	-	scene	Low
↕	Floor Heating	73	Setpoint temperature, Out		2 bytes	C	-	-	T	-	temperature (°C)	Low
↕	Floor Heating	74	Setpoint temperature, In		2 bytes	C	-	W	-	-	temperature (°C)	Low
↕	Floor Heating	75	Scene, In		1 byte	C	-	W	-	-	scene number	Low
↕	Floor Heating	76	Heating ON/OFF, Out		1 bit	C	-	-	T	-	switch	Low

NO.	Function	Name	Data length	Attribute	Data type DPT
69	External temperature, In	Floor Heating	2 bytes	C, W	temperature (°C)
This communication object is used to receive the temperature value from bus, and the temperature value on the device will be updated.					
70	ON/OFF, Out	Floor Heating	1 bit	C, T	Switch
			1 byte		counter pulses (0..255)
This communication object is used to send control command of Floor Heating on/off status to bus. Telegram value: ON OFF					
71	ON/OFF status, In	Floor Heating	1 bit	C, W	Switch
			1 byte		counter pulses (0..255)
The communication object is used to receive the status feedback value of Floor Heating on/off status. Telegram value: ON OFF					
72	Preset 1Bit, In	Floor Heating	1 bit	C, T	scene
The communication object is used to receive returning to the preset state command from bus. Telegram value: 0 1					
73	Setpoint temperature, Out	Floor Heating	2 bytes	C, T	temperature (°C)
This communication object is used to send the control telegram of Floor Heating setpoint temperature to bus. Telegram value: 16°C...30°C					
74	Setpoint temperature, In	Floor Heating	2 bytes	C, W	temperature (°C)
The communication object is used to receive the temperature setting value from bus, and the temperature setting value on the device will be updated. Telegram value: 16°C...30°C					
75	Scene, In	Floor Heating	1 byte	C, T	scene number
This communication object is used to recall the scene control of floor Heating. The parameter is set to the scene No.1~64, and the actual corresponding telegram value is 0~63.					
76	Heating ON/OFF, Out	Floor Heating	1bit	C,T	switch
This communication object is used to send the control telegram of Floor Heating ON or OFF to bus. Telegram value: ON OFF					