

230 V standard

CONTENTS

Page

1. Description	1
2. Installation	2
3. Operation	3
4. Connection	3
5. Maintenance	4
6. Compliance and approvals.....	5
7. Equipment and accessories	5

1. DESCRIPTION

IP 42 - IK 07 emergency lighting luminaires with LEDs
Class II: 

Cat. No.	Flux/ standby power	Mode	M pwr cons. (W)	NM pwr cons. (W)	Batteries	No. of LEDs
6 600 51	70 lm/1 hr	NM	-	1.45	Ni-Cd	2
6 600 52	100 lm/1 hr	NM	-	1.45	Ni-Cd	2
6 600 53*	100 lm/1 hr	NM	-	1.45	Ni-Cd	2
6 600 54	200 lm/1 hr	NM	-	2.2	Ni-Cd	4
6 600 57	200 lm/2 hrs	NM	-	0.4	Ni-MH	6
6 600 59	100 lm/3 hrs	NM	-	1.9	Ni-Cd	4
6 600 60*	100 lm/3 hrs	NM	-	1.9	Ni-Cd	4
6 600 72	100 lm/1 hr	M/NM	2.2	0.8	Ni-Cd	4
6 600 74	200 lm/1 hr	M/NM	2.4	1	Ni-Cd	4
6 600 75	350 lm/1 hr	M/NM	1.9	0.4	Ni-MH	8
6 600 77	200 lm/2 hrs	M/NM	1.9	0.4	Ni-MH	6
6 600 79	100 lm/3 hrs	M/NM	2.5	1	Ni-Cd	4
6 600 80*	100 lm/3 hrs	M/NM	2.5	1	Ni-Cd	4

* products supplied with label

1. DESCRIPTION (CONTINUED)

• Dimensions

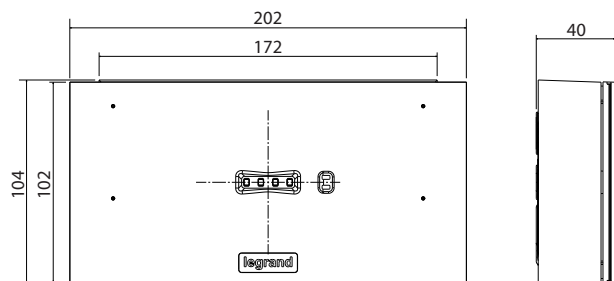

• Technical characteristics

Power supply: 230 V~ - 50/60 Hz
Equipped with screw terminals 2.5 mm² max. (draw-out connector).
Class II: 
Operating temperature: 0°C to +40°C
Connection to remote control 0 039 00/01 for setting to rest mode during intentional mains power breaks.
Remote control input terminals protected against connection errors.

Conforming to standards: UNE EN 60598-2-22: 2014 + AMD: 2020
Awarded ENEC EN 60 598 2-22 quality mark and AENOR quality mark
(Made in Spain only).
Product for surface mounting on walls or ceilings and flush mounting in ceilings with accessory 6 601 95/95BK.

1. DESCRIPTION (CONTINUED)

• **Materials**

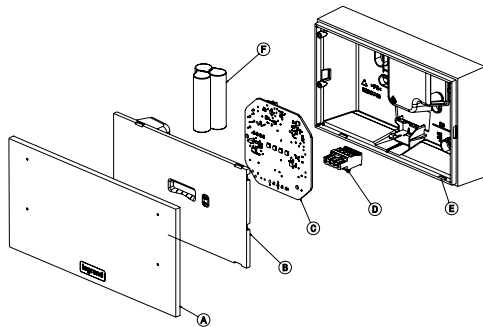

- (A) Diffuser: opal polycarbonate, self-extinguishing 850° 30 s
- (B) Reflector: white polycarbonate, self-extinguishing 850° 30 s
- (C) Circuit board
- (D) Power supply and remote control connector
- (E) Base: white polycarbonate, self-extinguishing 850° 30 s
- (F) Battery pack

All plastic parts weighing more than 50 g are marked with their material type so that the materials can be recycled at the product's end of life.

2. INSTALLATION

• **Opening the unit**

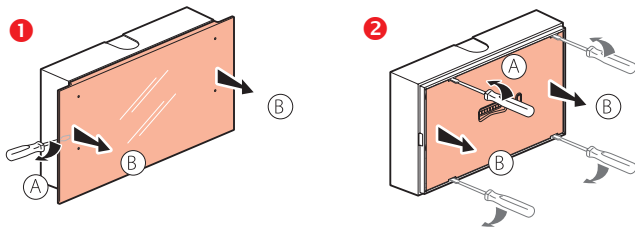

• **Fixing the base**

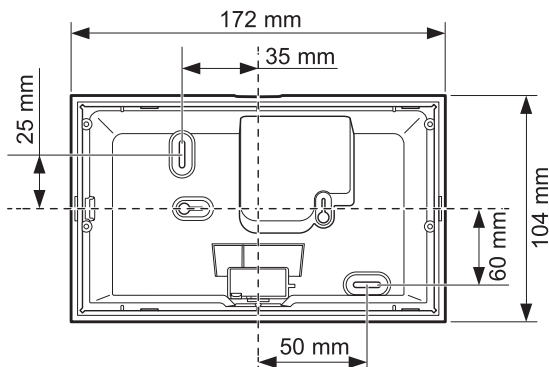

2. INSTALLATION (CONTINUED)

• **Wiring**

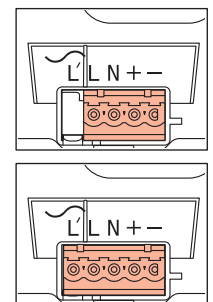
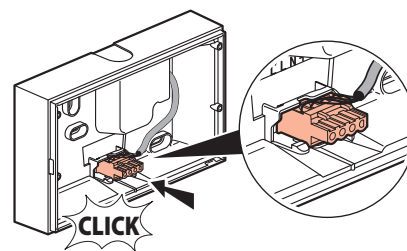
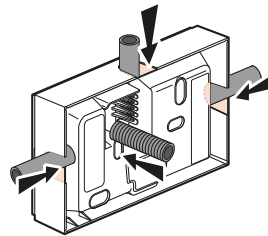
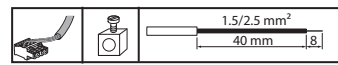

TELEC - Connection terminals: direction of connection with Legrand remote control Cat. No. 0 039 00/01 must be complied with.
 Terminal capacity: 2.5 mm² max

• **Wiring up NM products**

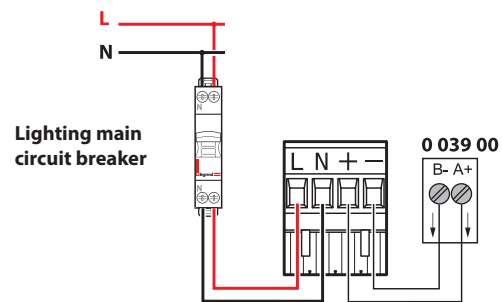

• **Wiring up M-NM products**

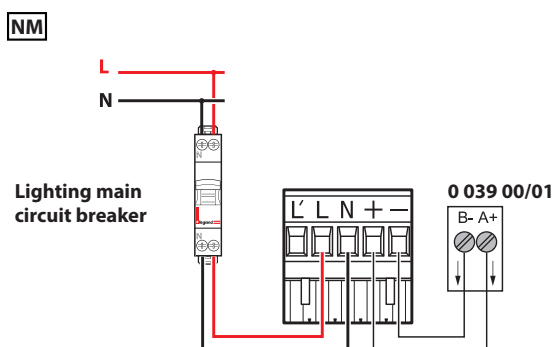

2. INSTALLATION (CONTINUED)

• Wiring up M-NM products (continued)

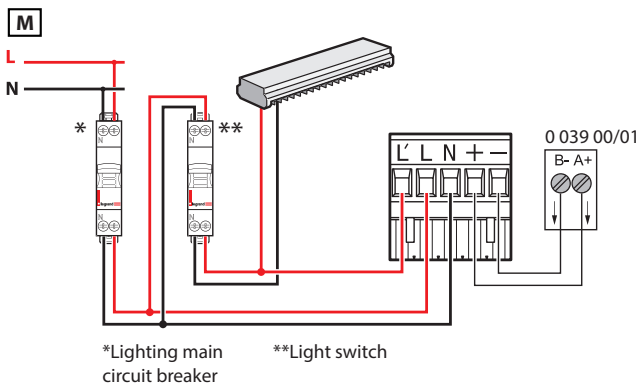

Note: Although self-contained emergency lighting units do not consume much power, you must check that the line dedicated to these lighting units can deliver the necessary current. You will find below the current the line needs to withstand for 100 installed lighting units according to the catalogue number (for simplicity, we have assumed just one type of lighting unit is installed per line):
 100 x 6 600 54/59/60 current = 7 A; 100 x 6 600 51/52/53 current = 5 A;
 100 x 6 600 24/72/74/75/77/79/80 current = 1 A

3. OPERATION

■ 3.1 Switch-on/standby state

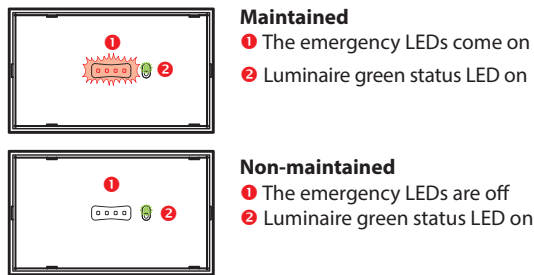

■ 3.2 Mains supply break/emergency operation

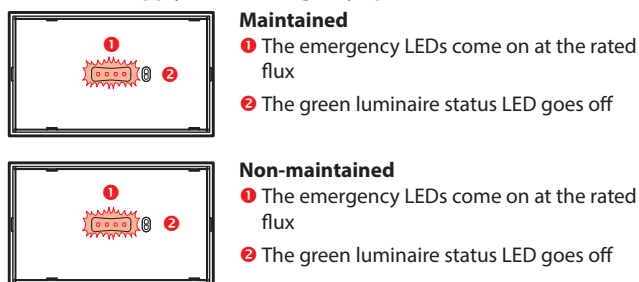

■ 3.3 Setting to rest state via the remote control Cat. No. 0 039 00/01

After the lighting is switched off intentionally:
Pressing the button sets the luminaire to rest state to prevent the battery discharging.

Lighting switched back on:
The luminaire automatically returns to standby in its initial operating mode.

■ 3.4 Testing emergency lighting luminaires

They can be tested by disconnecting the main power supply:
 - they are working correctly if the emergency LEDs come on.
 - the rated standby power is correct if the emergency LEDs stay on for the whole of the rated standby power time.

4. CONNECTION

■ 4.1 Connection of emergency lighting luminaires to the mains power

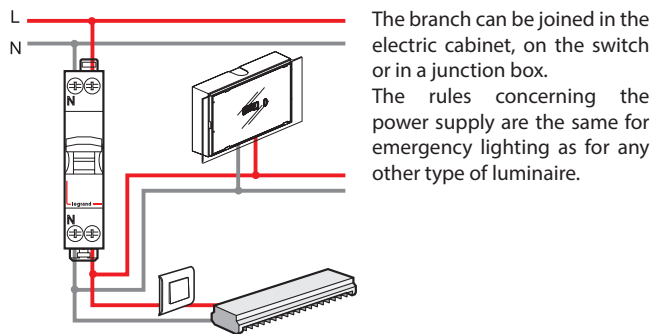

The branch can be joined in the electric cabinet, on the switch or in a junction box. The rules concerning the power supply are the same for emergency lighting as for any other type of luminaire.

■ 4.2 Connecting the remote control

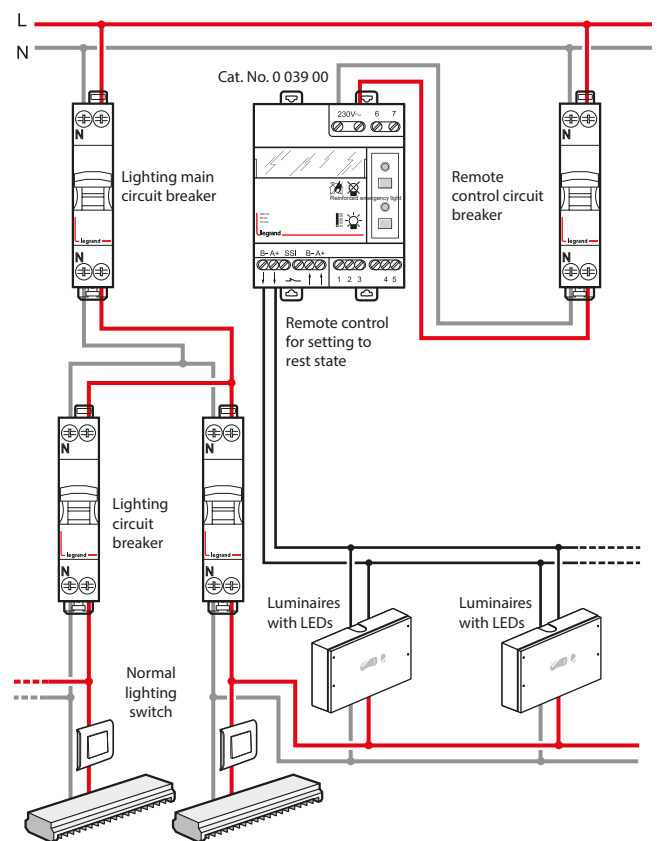

Note:
 If performing a mains power present test (press the ALL button on remote control 0 039 00), catalogue numbers 6 600 51/52/53/54/72/74 will follow the remote control commands: 1 s ON/4 s OFF/1 s ON; no need to press the EXT button to reset them to standby state.
 If nothing happens, check the polarity of the remote control.
 For the other catalogue numbers in this technical data sheet, the EXT button needs to be pressed to reset them to standby state.
 In the event of interference on the remote control line or unwanted switching on of the self-contained emergency lighting units: add a 1 kohm resistor between the A+ and B- terminals on remote control 0 039 00 (this resistor is supplied with the remote control).

5. MAINTENANCE

■ 5.1 Spare parts

Luminaire Cat. No.	Battery	Spare battery Cat. No.
6 600 51/52/53/72	3.6 V 0.7 Ah Ni-Cd	6 601 80
6 600 54/59/60/74/79/80	3.6 V 1.1 Ah Ni-Cd	6 601 81
6 600 57/75/77	3.6 V 1.5 Ah Ni-MH	6 601 84

■ 5.2 Replacing the batteries

The batteries must be replaced when the self-contained luminaire can no longer stay on for its rated operating time.

Caution: The product must be switched off before dismantling.

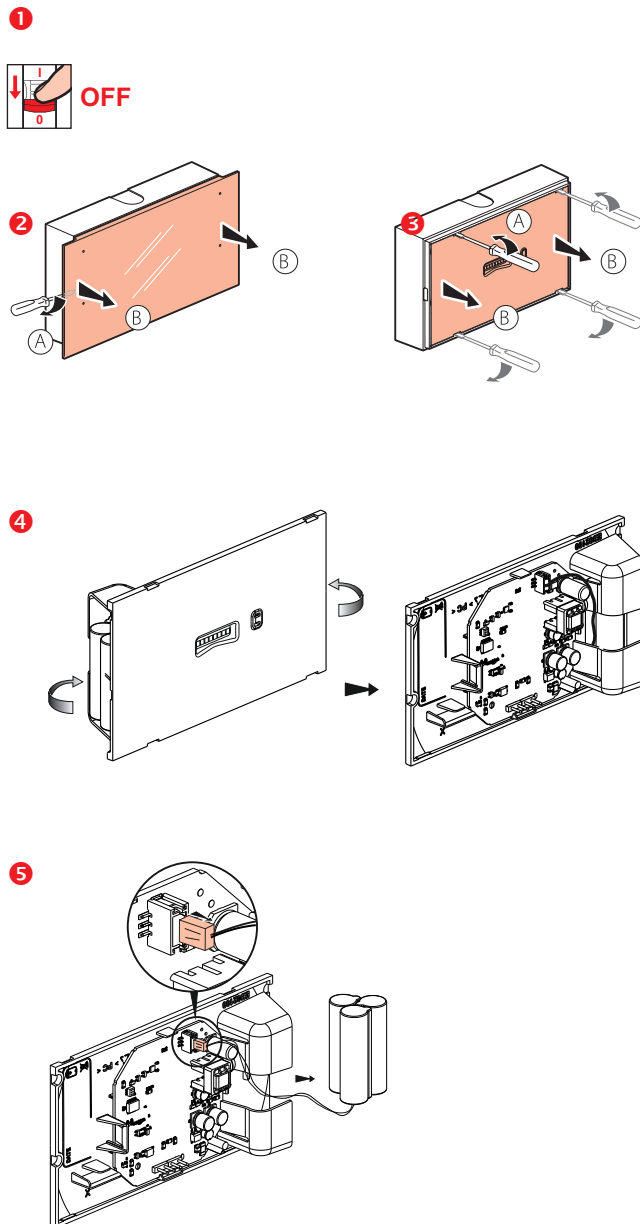

5. MAINTENANCE (CONTINUED)

■ 5.2 Replacing the batteries (continued)

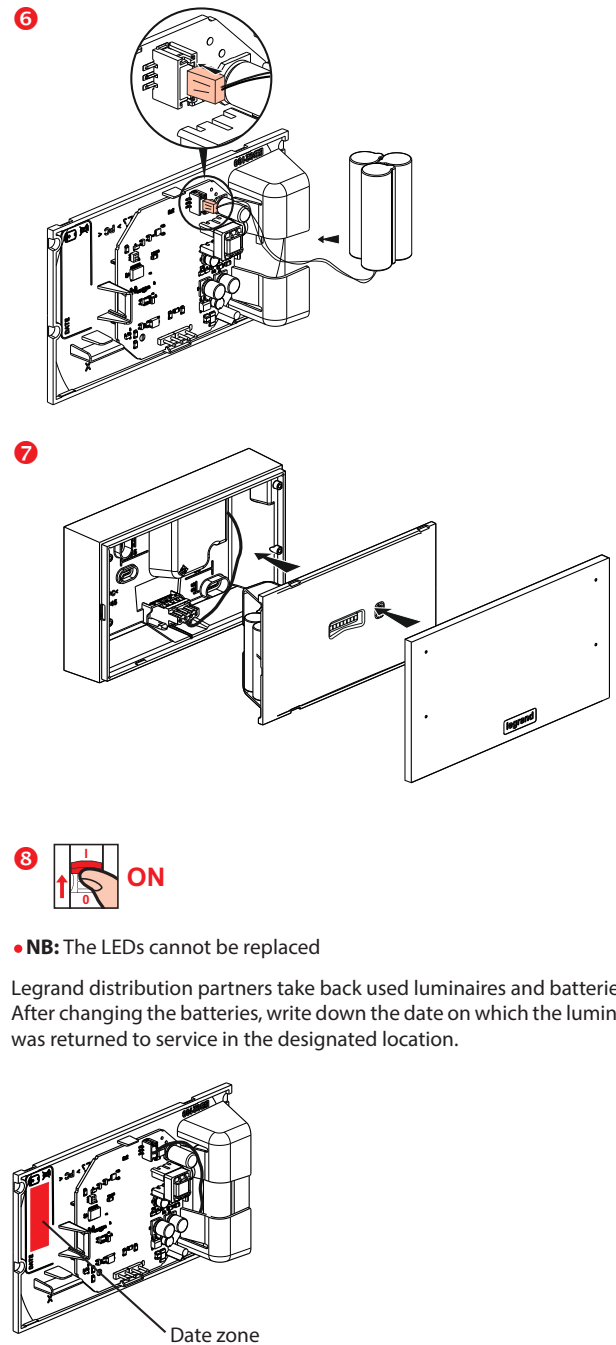

5. MAINTENANCE (CONTINUED)

■ 5.3 Troubleshooting

All the LEDs are off:



Check whether at least one of these faults is present:

- The battery is disconnected
- The battery has a voltage fault
- The charger and/or the electronics have a fault
- The light source has a fault

Recommendations:

For catalogue numbers with Ni-Cd batteries, we recommend completely discharging the self-contained emergency lighting units by manually disconnecting the power supply every 3 months in order to optimise the performance of the self-contained units.

6. COMPLIANCE AND APPROVALS

EN 60598-2-22: 2014 + AMD: 2020: European standard "Luminaires: specific rules. Luminaires for emergency lighting"
EN 60598-1 2015 + A1 2018: European standard "Luminaires".
EN 50172: European standard "Emergency lighting systems"
EN 1838: European standard "Lighting applications – Emergency lighting"
Products certified with the AENOR N mark (Made in Spain only).

Electromagnetic effects: EMC

Emission

- EN 55015 (disturbance voltages)
- EN 61000-3-2 (harmonic measurements) class C
- EN 55022 (radiated interference) class B

Immunity

- EN 61000-4-2 (electrostatic discharges)
- EN 61000-4-3 (radiated fields)
- EN 61000-4-4 (fast transients/bursts)
- EN 61000-4-5 (lightning impulses)
- EN 61000-4-6 (radiated fields)
- EN 61000-4-8 (magnetic fields)
- EN 61000-4-11 (voltage dips and short interruptions)

7. EQUIPMENT AND ACCESSORIES (CONTINUED)

IP 66/IK 10 weatherproof box, 6 601 91

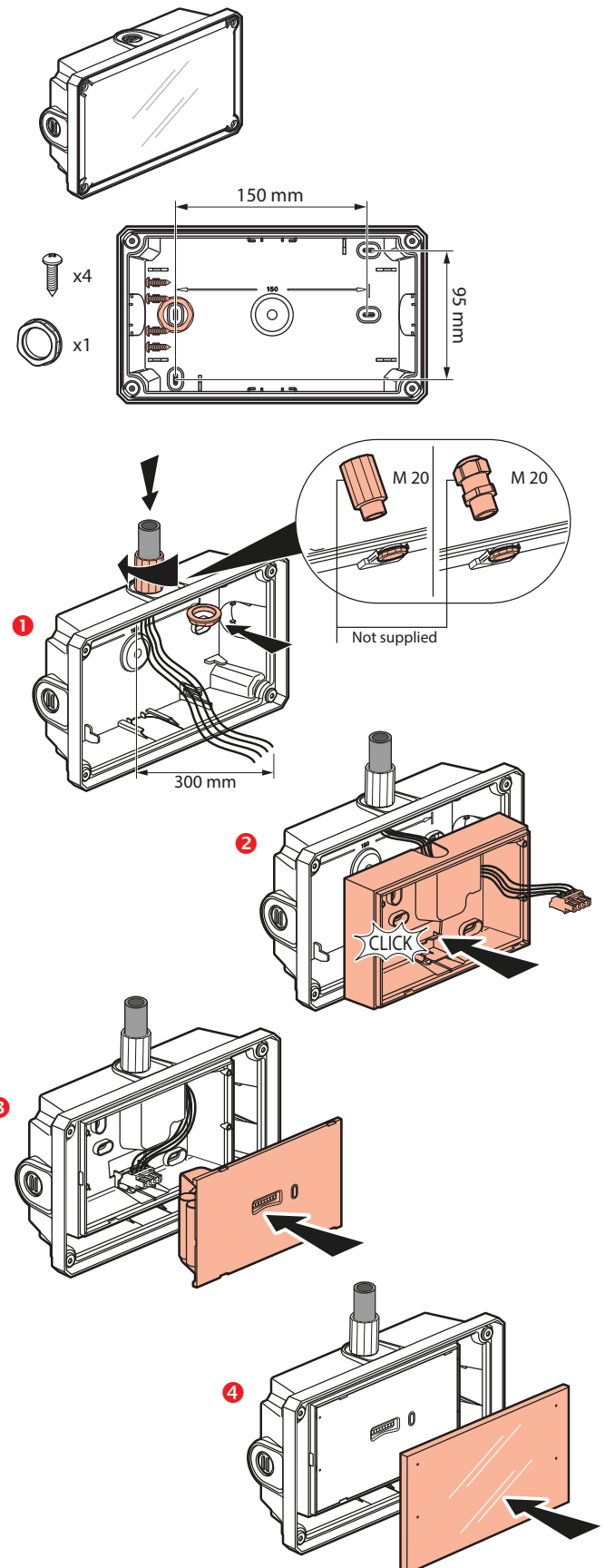

7. EQUIPMENT AND ACCESSORIES (CONTINUED)

IP 66/IK 10 weatherproof box, 6 601 91 (continued)

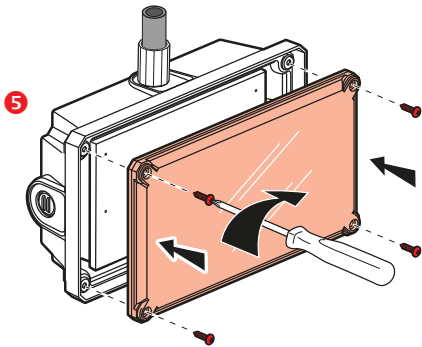

Vertical sign plate Cat. No. 6 601 93

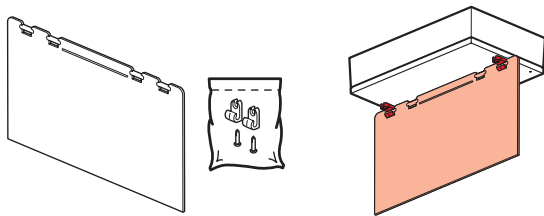

Legend stickers (not supplied):

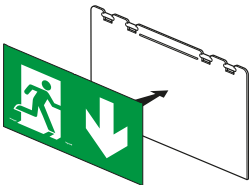

- Conforming to standard EN ISO 7010:



6 616 70

- Other available solutions:

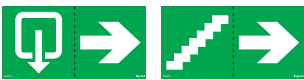

6 616 71

6 616 72



6 616 80

6 616 82

6 616 83

6 616 85



6 616 88

6 616 89

6 616 90

6 616 91

7. EQUIPMENT AND ACCESSORIES (CONTINUED)

Flush-mounting box Cat. No. 6 601 95 - 6 601 95BK

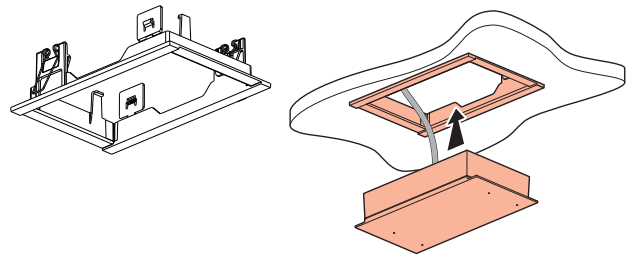

Adaptor for replacing U21 units, 6 601 92

