



CONTENTS	Page
1. Use	1
2. Technical characteristics	1
3. Dimensions	2
4. Connection	2
5. Installation	4
6. Operation	4
7. Parameter setting	5
8. Troubleshooting	8
9. Performance	9
10. Care	9
11. Standards	9

1. USE

This microwave presence detector provides automatic control of lighting loads with optional manual control. It detects movement using a highly sensitive microwave detector. This works by emitting low-power microwave signals and measuring the reflections as the signals bounce off moving objects.

Output channel 1 comprises a mains voltage relay capable of simple on/off switching, while output channel 2 provides dimmable control of either DALI or DSI type ballasts and turns the load on. When an area is no longer occupied, the load will switch off after an adjustable timeout period.

These units come complete with accessories allowing flush mounting in suspended ceilings or surface mounting on ceilings, or side mounting on a luminaire.

The unit can turn lights on when a room is occupied and off when the room is empty. Optional settings allow lights to be turned off in response to ambient daylight.

The flexibility of having two output channels and two switch inputs allows the following example scenarios:

- Dimming an outside row of luminaires whilst internal fittings are switched
- Providing absence detection for two separate channels
- Installing a maintained illuminance system with manual override controls for dimming

This detector has an adjustable sensor head that allows the detection area to be optimised for the application.

All functionality is fully programmable using an infrared configurator.

2. TECHNICAL CHARACTERISTICS

Microwave sensor

Detects movement within the unit's detection range, allowing load control in response to changes in occupancy.

IR receiver

Receives control and programming commands from the infrared configurator.



2. TECHNICAL CHARACTERISTICS (CONTINUED)

Light level sensor

Measures the overall Lux level in the detection area.

LED status

The LED flashes red to indicate the following:

Walk test LED active		<i>When movement is detected</i>
Valid setting received		

Power input & switched output connector (channel 1)

Used to connect mains power to the unit and to connect a switched load

Dimmable control output connector (channel 2)

Used to connect DALI/DSI controllable ballasts for dimmable loads.

Switch input connector

Two input terminals can be used to manually override the dimming levels and override the lights on or off.

Dimensions	See dimensions section
Weight	0.15 kg
Power supply	230 VAC +/-10%
Frequency	50 Hz
Power consumption	ON 1500 mW, OFF 961 mW
Terminal capacity	1.5 mm ²
Dimming outputs	Basic insulation only. Although low voltage, this is not a SELV output and should be treated as if it were mains voltage. Use mains rated wiring.
Operating temperature	-10°C to +50°C
Operating humidity	5 to 95% non-condensing
Material	Flame-retardant ABS and PC/ABS
Type	Class 2
Protection class	IP40

2. TECHNICAL CHARACTERISTICS (CONTINUED)

	①	②	③	④	⑤	1 - Halogen lamps 2 - ELV halogen lamps with separate ferromagnetic ballast 3 - Fluorescent tubes with separate ferromagnetic ballast 4 - Compact fluorescent lamps with separate ferromagnetic ballast 5 - ELV halogen lamps with separate electronic ballast
						6 - Fluorescent tubes with separate electronic ballast 7 - Compact fluorescent lamps with built-in electronic ballast 8 - Compact fluorescent lamps with separate electronic ballast 9 - LED lamps with separate electronic ballast 10 - LED lamps with built-in electronic ballast
230 V~	10 A	10 A	10 A	10 A	10 A	
	⑥	⑦	⑧	⑨	⑩	
230 V~	10 A	10 A	10 A	10 A	10 A	

3. DIMENSIONS

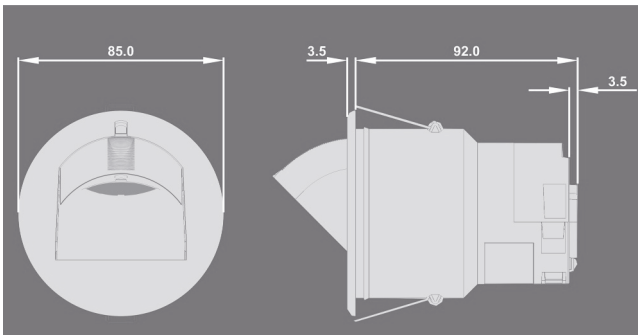

4. CONNECTION

Channel 1 (switched output) can either be used to switch a set of luminaires, or to isolate the mains supply of DALI/DSI dimming ballasts (saving on the standby consumption of the ballasts). Multiple loads can be connected in parallel as long as the maximum total load is not exceeded.

Channel 2 (dimnable output) can be used to dim DALI/DSI ballasts or dimming transformers. The ballasts/transformers can be connected in parallel as long as the maximum number is not exceeded.

The wiring examples below show common installations using this detector.

4. CONNECTION (CONTINUED)

Single channel dimming with manual dimming control

Functions: Switching the luminaire according to occupancy and maintaining a defined lighting level. Override dimming and switching using a centre-biased retractive switch.

Configured for presence detection: Turns on automatically when occupancy is detected. Maintains the lighting level. Press and release the down button to turn off, press and release the up button to turn back on. Press and hold the down button to dim down, press and hold the up button to dim up. Turns off automatically when occupancy is no longer detected.

Configured for absence detection: Press and release the up button to turn on. Maintains the lighting level. Press and release the down button to turn off, press and release the up button to turn back on.

Press and hold the down button to dim down, press and hold the up button to dim up. Turns off automatically when occupancy is no longer detected.

Channel mode: Set to "Switch and dim together".

Manual control mode: Set to "Synchronised 1-position push-button".

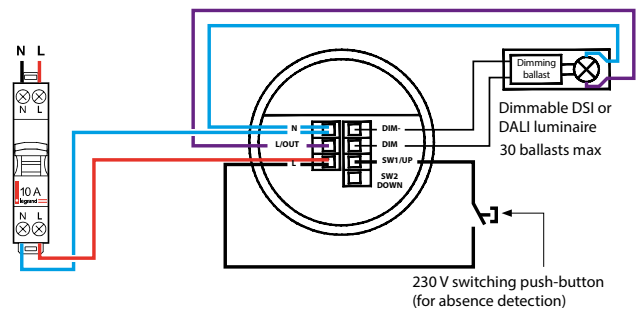

4. CONNECTION (CONTINUED)

Two channels (switch & dim) with two dedicated manual controls

Functions: Switching the luminaire according to occupancy and maintaining a defined lighting level. Override dimming using a single push-button and switching using a second single push-button.

Configured for presence detection: Turns on automatically when occupancy is detected. Maintains the lighting level (dimming channel only). Press and release the switch to toggle on and off (switching channel only). Press and release the switch to toggle on and off, press and hold the switch to dim up and down (dimming channel only). Both channels turn off automatically when occupancy is no longer detected.

Configured for absence detection: Press and release the up button to turn on. Maintains the lighting level (dimming channel only). Press and release the switch to toggle on and off (switching channel only). Press and release the switch to toggle on and off, press and hold the switch to dim up and down (dimming channel only). Both channels turn off automatically when occupancy is no longer detected.

Channel mode: Set to "Switch and dim separately".

Manual control mode: Set to "Separate 1-position push-button".

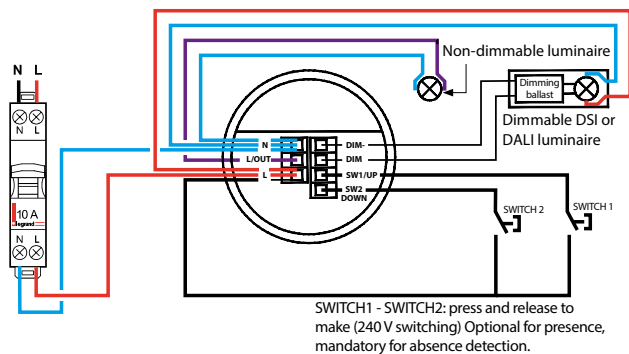

Two channels (switch & dim) with a single manual control for dimming

Functions: Switching the two lighting outputs according to occupancy and maintaining a defined lighting level for the dimming channel. Override dimming and switching using a centre-biased retractable dimming for the dimming channel only.

Configured for presence detection: Turns on automatically when occupancy is detected. Maintains the lighting level (switching channel only). Press and release the down button to turn off, press and release the up button to turn back on (dimming channel only). Press and hold down the down button to dim down, press and hold the up button to dim up (dimming channel only). Both channels turn off automatically when occupancy is no longer detected.

4. CONNECTION (CONTINUED)

Two channels (switch & dim) with a single manual control for dimming (continued)

Configured for absence detection: Press and release the up button to turn on. Maintains the lighting level (dimming channel only). Press and release the down button to turn off, press and release the up button to turn back on (dimming channel only). Press and hold down the down button to dim down, press and hold the up button to dim up (dimming channel only). Both channels turn off automatically when occupancy is no longer detected.

Channel mode: Set to "Switch and dim together".

Manual control mode: Set to "Synchronised 1-position push-button".

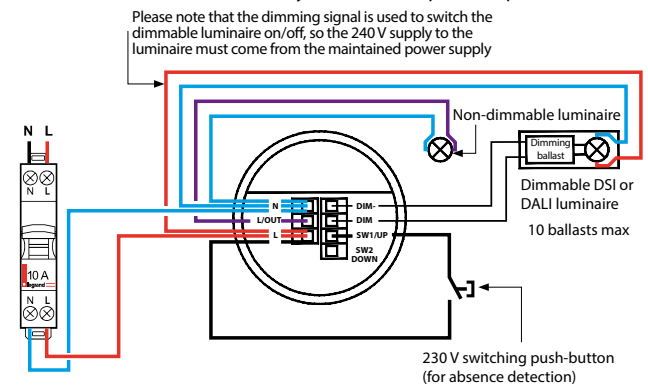

5. INSTALLATION

The product is designed to be flush-mounted in the ceiling.

The detector should be sited so that the occupants of the room are inside the detection area.

- Avoid direct sunlight entering the sensor.
- Do not site within 1 m of forced air heating or ventilation.
- Do not fix to a vibrating surface.
- Avoid having any metal objects positioned directly in front of the sensor head.

Flush mounting:

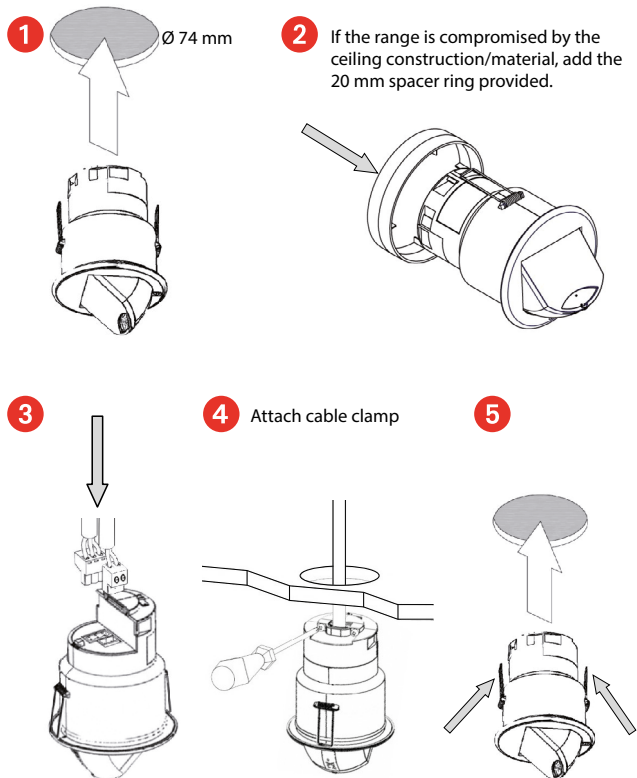

5. INSTALLATION (CONTINUED)

Locking the directional head:

- 1 Remove metal locking clip from rear of unit.
- 2 Adjust head to required position. Push clip into the position shown below to lock head. To remove clip, lever out with a small screwdriver.

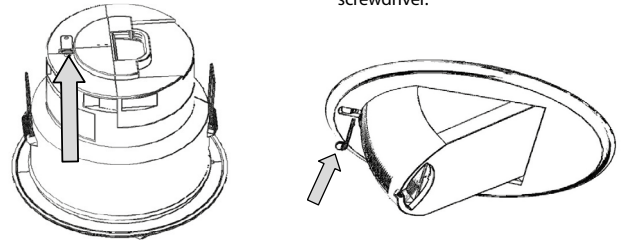

Power-up test procedure

When power is applied to the unit, the load will switch on immediately. Set the timeout to 10 seconds, vacate the room or remain very still and wait for the load to switch off.

Check that the load switches on when movement is detected.

The unit is now ready for programming.

6. OPERATION

Detection mode

Presence: When movement is detected, the load will automatically switch on. When an area is no longer occupied, the load will switch off automatically after an adjustable time period.

Absence: The load is manually switched on. When an area is no longer occupied, the load will switch off automatically after the adjustable time period has elapsed.

In either case, Presence/Absence, sensitivity to movement of the PIR sensor can be adjusted using the Sensitivity parameter.

HINT: To assist in setting the sensitivity, turn on the Walk test LED which will flash red when movement is detected.

6. OPERATION (CONTINUED)

Switching according to Lux level

Occupancy detection can be made dependent on the ambient light level using the Lux On Level and Lux Off Level parameters.

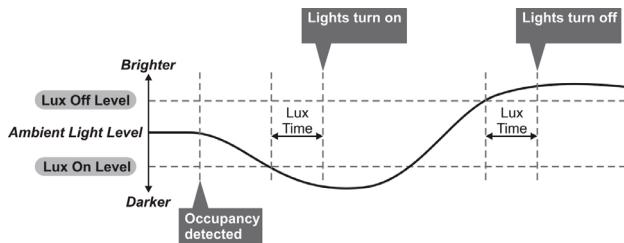

Regulation according to light level

The detector measures the overall light level in the detection area, then calculates and dims the luminaire lighting to achieve a preset Lux level (maintained lighting or daylight harvesting).

Burn-in

Overview - It is a requirement of many fluorescent lamp manufacturers to have the lamps on at maximum output for a period of time to guarantee lamp life (refer to the manufacturer’s data sheet for more details).

Operation - By setting the “Burn-in” parameter, you can select a time during which the lamps are not allowed to deviate from maximum dimming. The unit counts the time, and even remembers how long has elapsed in the event of a power failure. To cancel the burn-in function, simply select a time of 0. Note that when the lamps are changed, the burn-in time should be set again.

7. SETTINGS

• 0 882 40: Configuration gateway and Legrand Close Up application. The Close Up application is available on the Apple Store and the Play Store



The detector functions are controlled by a number of parameters which can be changed or programmed by an infrared configurator.

In combination with configuration tool 0 882 40, the Legrand Close Up smartphone app can be used to view and modify all the detector parameters with online help.

Point the infrared configuration tool at the detector and send the necessary programming commands to the unit as indicated in the table below.

For more information about setting parameters, refer to the data sheet for the configuration gateway Cat. No. 0 882 40.

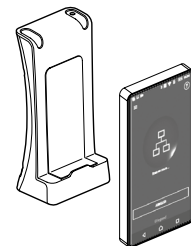

Valid commands will be indicated by a red flashing LED on the product, and the lighting switches off automatically for all read/write operations. Before changing the settings, an initialisation operation must be performed as suggested in the Legrand Close Up configuration app:

- 1 - Click on “Scan product settings”
- 2 - Click on “Settings details/copy”
- 3 - In the menu at the top right (...) select “Initialise”
- 4 - Click on “Write product settings”

This operation allows predefined setting of certain parameters.

7. SETTINGS (CONTINUED)

Parameter	Default value	Value after initialisation	Range/option	Description
Output channel modes				
Switching only	-	-	-	Only the relay part is used
Switch and dim together	✓	✓	-	The 2 outputs are synchronised and go ON/OFF at the same time
Switch and dim separately	-	-	-	The 2 outputs are not synchronised and the DALI luminaire can be turned off without switching the relay output OFF
General parameters				
LED operation test	Off	-	ON or Off	When this option is activated, a red LED on the sensor flashes when it detects movement. Use this function to check that the sensitivity levels are suitable.
Inhibit detection	No	-	Yes/No	Disables presence/absence detection so that the detector does not control switching, only dimming. Use this mode for light regulation without automatic control according to occupancy.
Timeout	20 minutes	-	0 to 99 minutes	Once the detector is turned on, this value sets how long the lights will stay on once movement has ceased. Select 0 for a 10-second period (for commissioning only).
Manual timeout period	10 minutes	-	0 to 99 minutes	<p>When a manual operation occurs, either via the switch input or the infrared, it invokes the timeout period.</p> <p>Example 1: a detector in presence mode has a detector timeout of 15 minutes and a manual timeout of 3 minutes. When the user leaves the room, they press the Off button. The sensor will revert to automatic mode after 3 minutes. Walking back into the room will turn the lights on.</p> <p>Example 2: using the settings above, the user turns the lights off (say for a presentation) but stays in the room. Every time a movement is detected, the manual timeout period is re-triggered, but if it doesn't pick up anything over a short period, the detector will revert to automatic mode. This means that the lights may come on inadvertently during the presentation, even if the occupants are still present during the manual timeout period, so adjust the timing carefully.</p>
On sensitivity	8	9	1 (min) to 9 (max)	Sensitivity level for detecting movement when the detector is already on.
Off sensitivity	8	9	1 (min) to 9 (max)	Sensitivity level for detecting movement when the detector is off.
On delay	0 minutes	-	0 to 99 minutes	The On delay allows the first channel to switch on after the second channel. A typical application for this would be when a detector is controlling lighting and air conditioning in an area. When the occupant is detected, the lighting will be turned on immediately, whereas the air conditioning may be turned on after 15 minutes. If the area is vacated before the detector times out, then the air conditioning will not have come on. The delay can be set for channel 1 only using this parameter.
Detection mode	Presence	-	Presence or absence	Presence mode allows the output to turn on when movement is detected and off when movement ceases. Absence mode allows the output to turn off when movement ceases, but must be manually turned on first.
Lux On level	999	145	1-950, 999: OFF dimming regulation	Sets a minimum light level below which the PIR sensor is enabled, allowing the lights to be turned on by movement. Note: The "Lux Off level" value must always be greater than the "Lux On level" value.

7. SETTINGS (CONTINUED)

Parameter	Default value	Value after initialisation	Range/option	Description
General parameters (continued)				
Lux Off level	999	225	1-950, 999: disabled	Sets a maximum light level above which the PIR sensor is disabled, preventing the lights from being turned on by movement.
Lux On time	0	-	0 to 99 minutes	When the ambient light drops below the Lux On Level, this is the delay before the lights come on. If at any time during the timed delay the Lux level position is reversed, the process is cancelled. A minimum time of 15 seconds is defined for a value of 0. If you try to turn on the lights using a manual control, the lights will come on regardless of the ambient light level. However, if there is sufficient ambient light, they will turn off again after the Lux Off time.
Lux Off time	0	1	0 to 99 minutes	When the ambient light exceeds the Lux Off Level, this is the delay before the lights go out. If at any time during the timed delay the Lux level position is reversed, the process is cancelled. A minimum time of approximately 15 seconds is defined for a value of 0.
Dimming parameters				
Lux level for regulation	999	150	1-950, 999: disabled	Sets a target light level to be maintained by the lighting system
Max value	99%	-	0 to 99%	Maximum dimming output level.
Min value	0%	82%	0 to 99%	Minimum dimming output level.
On value	99%	-	0 to 99%	Dimming output level when switched on (0-99).
Off value	0%	-	0 to 99%	Dimming output level when switched off (0-99). If a non-zero off value is set, the output will toggle between this value and completely off depending on the switch level On and Off values. For example, if it is light outside, the fittings will be off if there is no occupancy. If it is dark outside, they will adopt the preset off value. This feature is only enabled if "Min value" is set to 99.
Manual control modes				
Manual control mode	✓	-	Shared 2-position push-button	A single centre-biased retractive switch will be used to control both channels at the same time.
	-	-	Separate 2-position push-button	-
	-	✓	Synchronised 1-position push-button	A single push-button controls both channels at the same time.
	-	-	Separate 1-position push-button	-

8. TROUBLESHOOTING

1. If the load does not switch on

- Check that the live supply to the circuit is correct.
- Check that the load is functioning by bypassing the detector (link terminals L and L/Out).
- If the detection range is smaller than expected, see the Performance section. Rotating the sensor slightly may improve the detection range.

2. If the load does not switch off

- Ensure that the area is left unoccupied for longer than the timeout period.
- Ensure that the detector is not affected by circulating air, heaters or lamps.

3. In the event of "false tripping", reduce the sensitivity settings.

4. If the light level is often too low

- Increase and adjust the value of the "Lux level for regulation" parameter: from 150 up to 200.
- Adjust the value of the following parameters:
 - Lux On Level = Lux level for regulation - 5
 - Lux Off Level = Lux level for regulation x 1.5

Example:

- Lux level for regulation = 180
- Lux On level = 175
- Lux Off level = 270
- Lux Off time = 1
- Min value: 82%

5. If the lighting loads never switch off (minimal lighting)

- Reduce and adjust the value of the "Lux Off level" parameter" in steps of 10 or 20

Example:

- Lux level for regulation = 150
- Lux On level = 145
- Lux Off level = 215
- Lux Off time = 1
- Min value: 82%

6. If the light level is too high

- Reduce and adjust the value of the "Lux level for regulation" parameter.
- Adjust the value of the following parameters:
 - Lux On Level = Lux level for regulation - 5
 - Lux Off Level = Lux level for regulation x 1.5

Example:

- Lux level for regulation = 130
- Lux On level = 125
- Lux Off level = 195
- Lux Off time = 1
- Min value: 82%

9. PERFORMANCE

Detection area

For the classroom

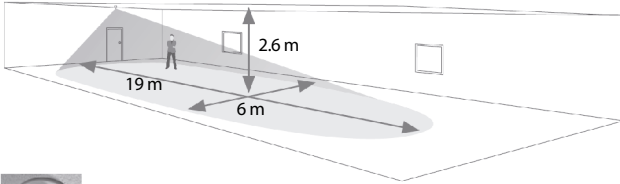

Sensitivity set to 80%
Detector head position set to 40°

High sensitivity area Low sensitivity area

For corridors and aisles

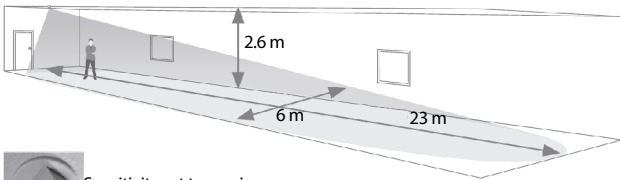

Sensitivity set to maximum
Detector head position set to 80°

High sensitivity area Low sensitivity area

For open-plan offices

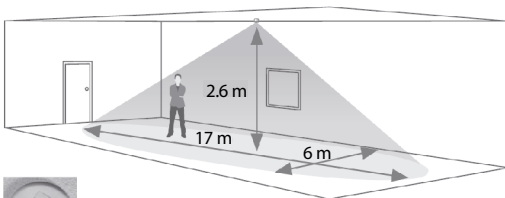

Sensitivity set to maximum
Detector head position set to 0°

High sensitivity area Low sensitivity area

10. CARE

Keep the lens clean, use a cloth to clean the surface.
Do not use acetone, tar-removing cleaning agents or trichloroethylene.

CAUTION: Always test before using other special cleaning products.

11. STANDARDS

- Directive: CE
- Installation standards: NFC 15-100
- Product standards: NF EN 60730-1
- Environmental standards:
- European Directive 2012/19/EU: WEEE (Waste Electrical and Electronic Equipment)
 - European Directive 2011/65/EU and 2015/863: RoHS (Restriction of Hazardous Substances)
 - Decrees and/or regulations: Public buildings, workplace buildings, high-rise buildings
 - RED Directive: 2014/53/EU