

Indice

General description	4
Hotel Room Supervision user manual	6
Authentication	7
Home page	8
Views	10
Room management	11
Thermostat settings	12
Parameters	14
Management of users	14
Preferences	18
Management of temperatures	18
Information	19
Legal Notices	20
Logout	20

General description

With the use of specific devices, the UXOne hotel system allows the user to control various functions of their own room, while the manager can supervise all the rooms in the hotel.

Functions such as:

- Room status (presence, make up room MUR, do not disturb DND)
- Heating/Air conditioning
- Automation
- Lighting
- Scenarios
- Access control

can be controlled by the customer via the UXOne connected thermostat and other devices in the room (e.g. DND/MUR controls).

The reception desk can supervise the rooms and common areas using the Hotel Room Supervision software in conjunction with the Hotel server.

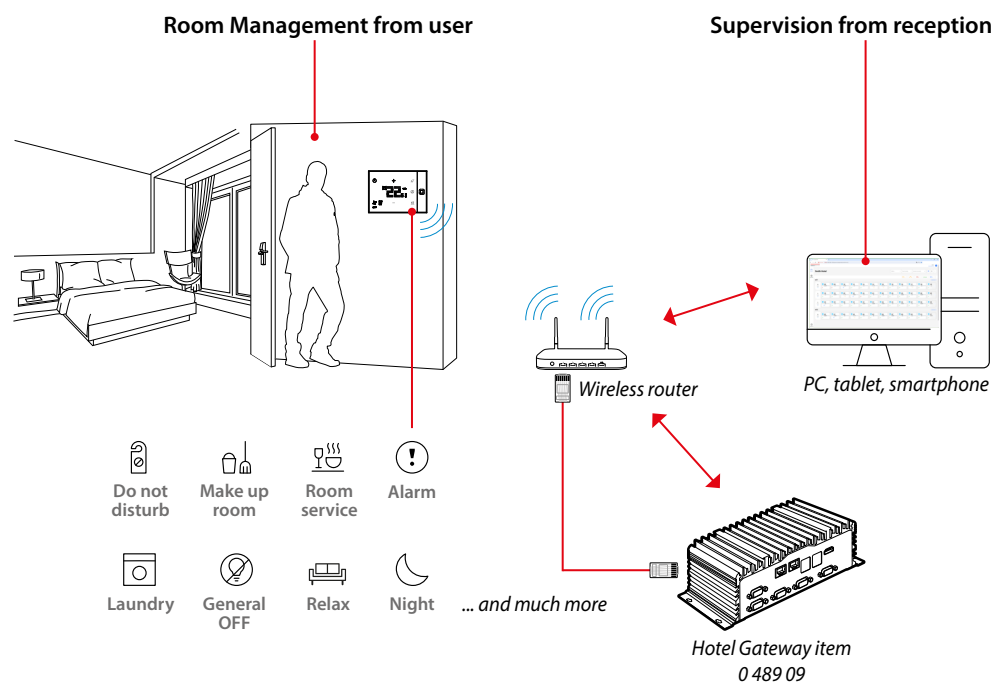

Therefore, this manual consists of 2 parts:

Hotel Room Supervision user manual

This chapter provides all the information on how to remotely supervise rooms using the Hotel Room Supervision software



UXOne thermostat user manual

This chapter consists of a short, customisable guide explaining the functions of the thermostat. Since the available functions depend on the type of thermostat and the configuration made by the installer, the guide can be customised for each room and given to the customer.



Hotel Room Supervision user manual

To access Hotel Room Supervision, type an http address into a browser to connect with the Hotel server pages.

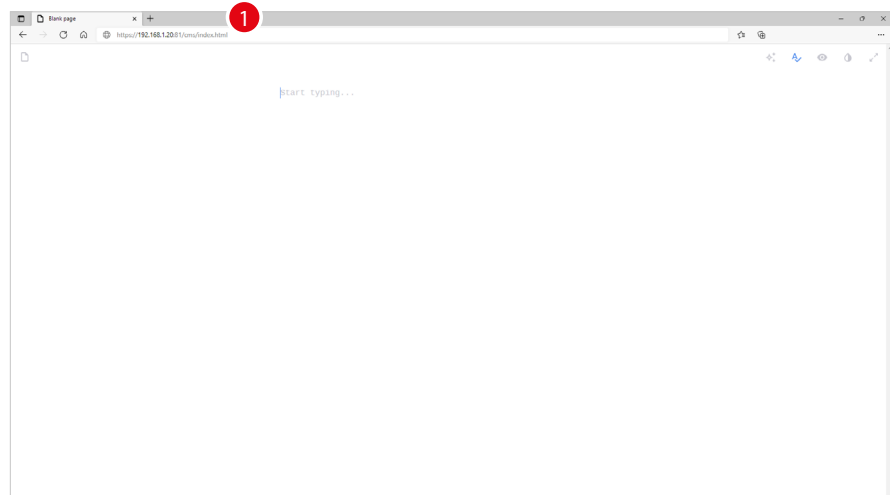

1. Open the browser and enter the http address of the Server:

`http://indirizzo IP Server/supervisor/app/index.html#/login`

NOTE: Ask your installer to give you the IP address of your Server.

NOTE: Use Chrome/Firefox/Edge/Safari (mac) browsers, with a recommended screen resolution of 1920x1080

Chrome: Version 124.0.6367.156 (Official build) (64 bit)

Firefox: Version 125.0.3 (64 bit)

Edge: Version 124.0.2478.80 (Official build) (64-bit)

Safari (mac): Version 17.4.1 (18618.1.15.111.8,18618)

In some cases, the browser may consider the page to be unsafe.

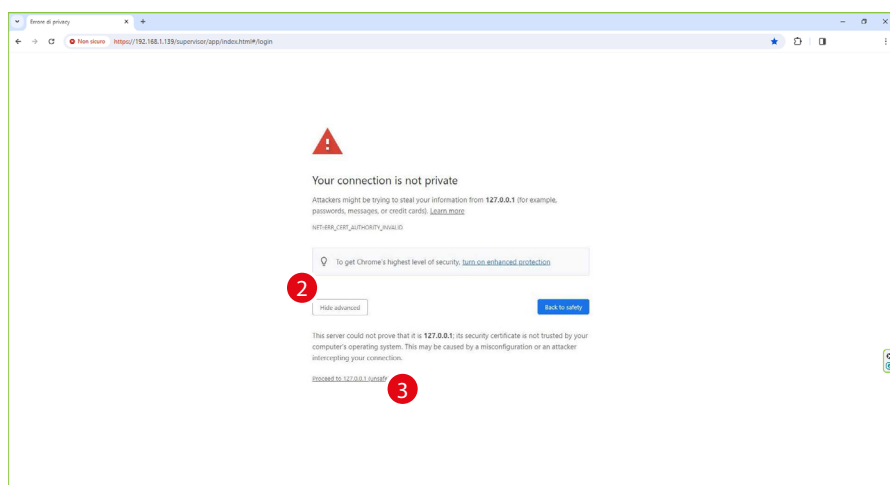

2. Click to display the advanced options
3. Click to ignore the warning and proceed

Authentication

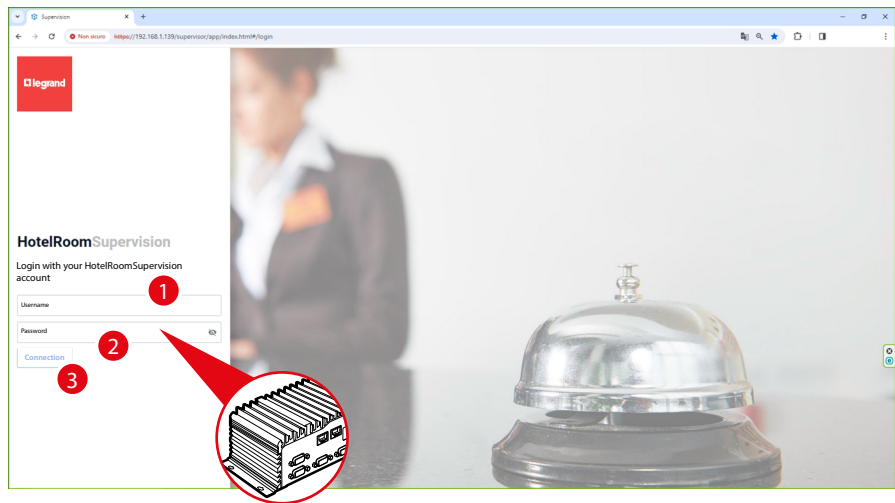

1. Enter the user name (Admin).
2. Enter the Admin password: (the password to access Hotel Room Supervision can be found on the Hotel Server label)

NOTE: The password can be changed in the **specific menu**, However, the password on the label will still remain valid.

3. Click to access Hotel Room Supervision.

A screen will open, showing the legal notices and the privacy policy.

NOTE: The legal document screens only appear during the first login. Later on they can be viewed by accessing the **Information** section.

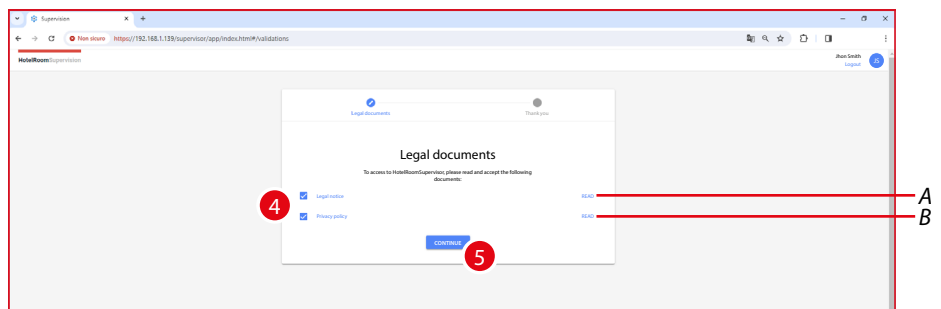

A Read the legal notices

B Read the privacy policy



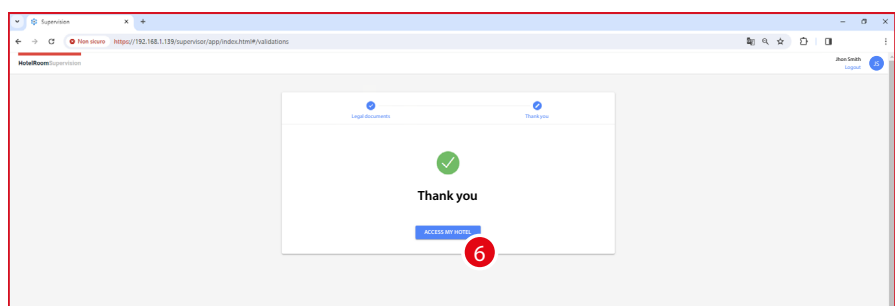





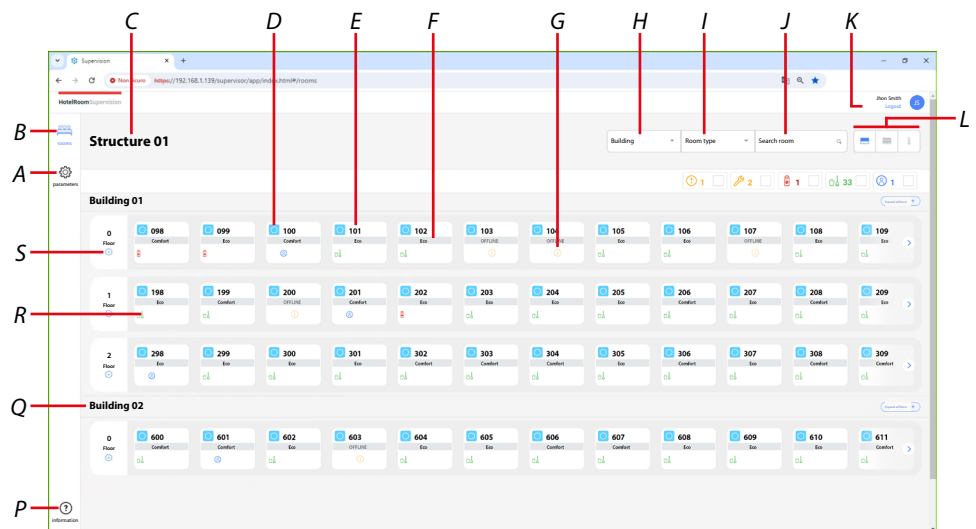

4. Click to accept the legal notices and the privacy policy
5. Click to continue



6. Click to access Hotel Room Supervision, the **Home page** will appear

Home page



- A [Parameters page](#)
- B Rooms page
- C Project name
- D Room occupancy status icons: Free room

- E Name/number of the room
- F Temperature control setpoint mode active in the room
- G Room status icons:
 -  Room in not-in-use status (UXOne disconnected)
 -  Rooms in maintenance status
 Room information icons:
 -  1 Do Not Disturb request active
 -  3 Make Up Room request active
 -  1 Guest in room status active
- H Building selection filter
- I Room type selection filter
- J Room search field
- K [Logout](#)
- L [Views](#)
- M Room status filter:
 -  1 Room in not-in-use status (UXOne disconnected)
 -  2 Rooms in maintenance status
 Room info filter:
 -  1 Do Not Disturb request active
 -  33 Make Up Room request active
 -  1 Guest in room status active

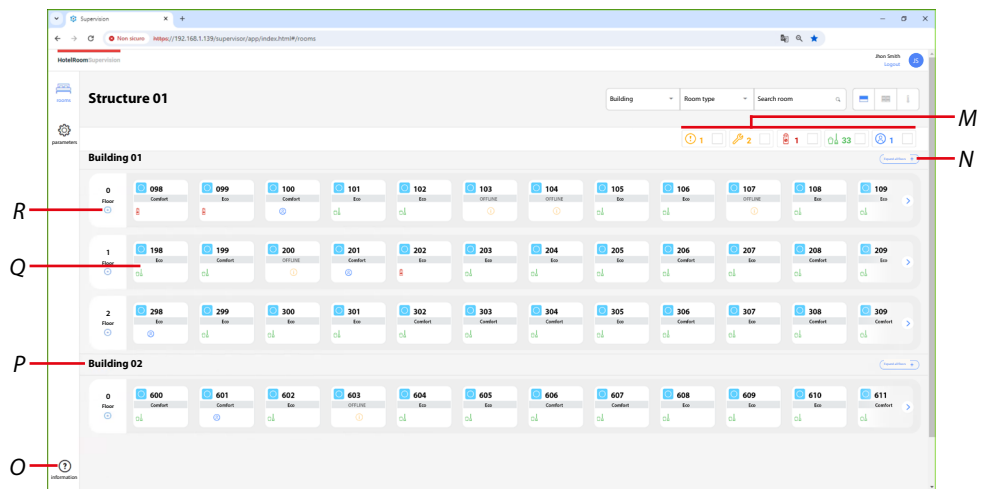
Home page



- N* [View all floors](#)
- O* [Information](#)
- P* [Building name](#)
- Q* [Open room page](#)
- R* [Expands the floor rooms](#)

Views

Rooms can be viewed using 3 different types of views:

Extended view: the extended view shows all the statuses of the room

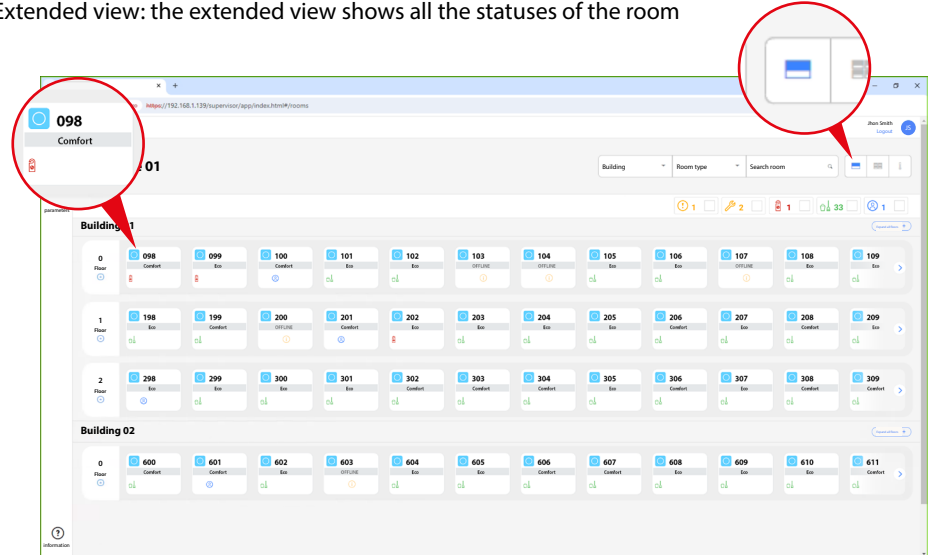

Reduced view: the reduced view only shows information regarding the status of the room

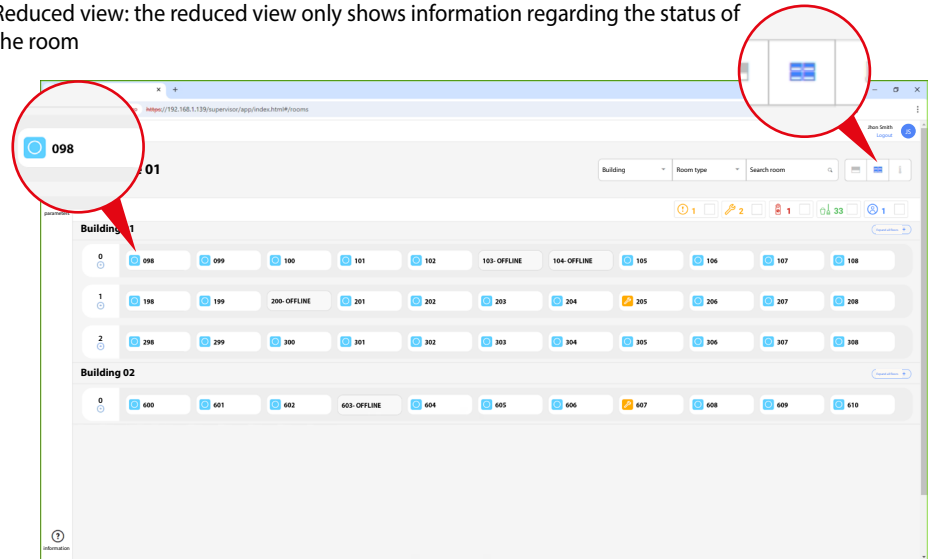

Temperature control view

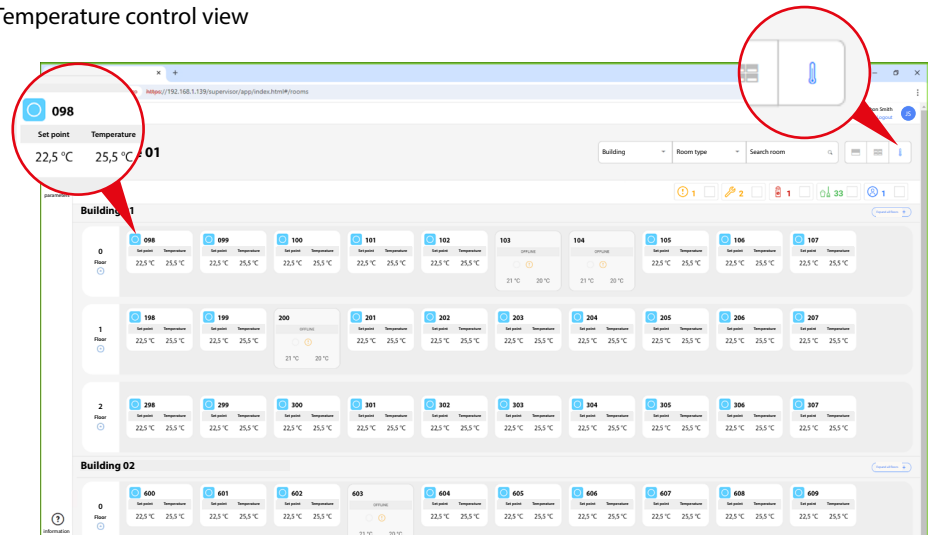

Room management

This page can be used to view the room status, manage the temperature control system, start scenarios and set the maintenance status.

NOTE: Some functions described in this manual may not be available for some UXOne models.

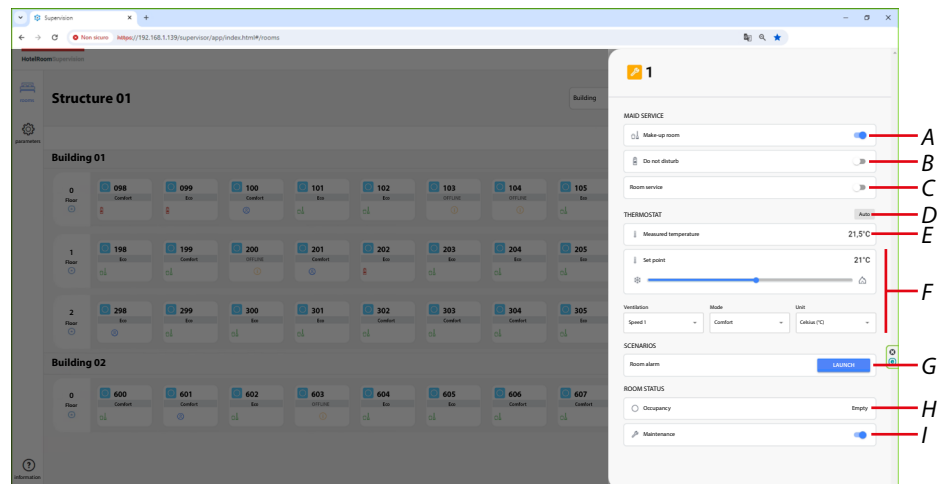

- A Activation/deactivation of the function set on the top button of UXOne “e.g. Make Up Room”
- B Activation/deactivation of the function set on the central button of UXOne “e.g. Do Not Disturb”
- C Activation/deactivation of the function set on the bottom button of UXOne “e.g. Maid services request” (equivalent to a generic service request, customisable for each hotel)

NOTE: the functions associated with the buttons depend on the type of UXOne installed and the configuration carried out by the installer. Items 465001- 465003 do not have scenario pushbuttons.

- D Active temperature control mode: heating/cooling or automatic
- E Measured temperature
- F **Thermostat settings**
- G Available scenarios
- H Shows if someone is in the room
- I Setting of the “Room in maintenance” status

Thermostat settings

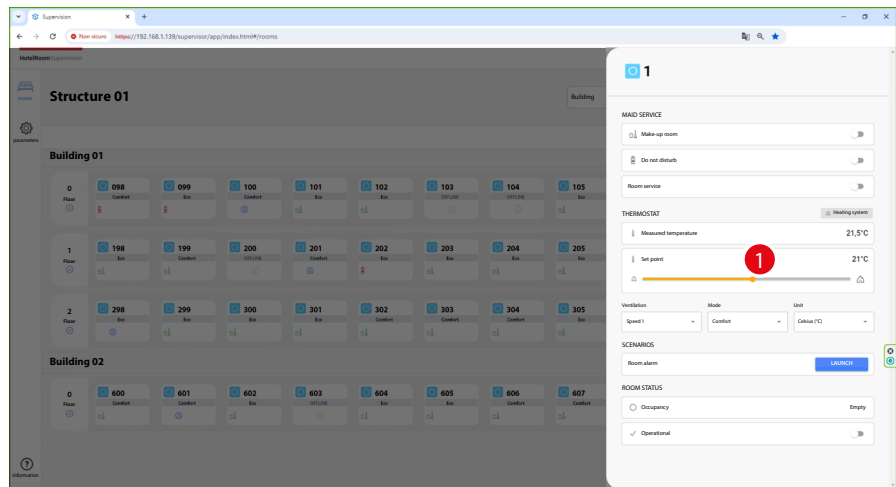

1. Click and drag to increase/decrease the temperature

NOTE: The manual setting of the temperature is only available if a Comfort temperature setpoint (A) is set on UXOne.

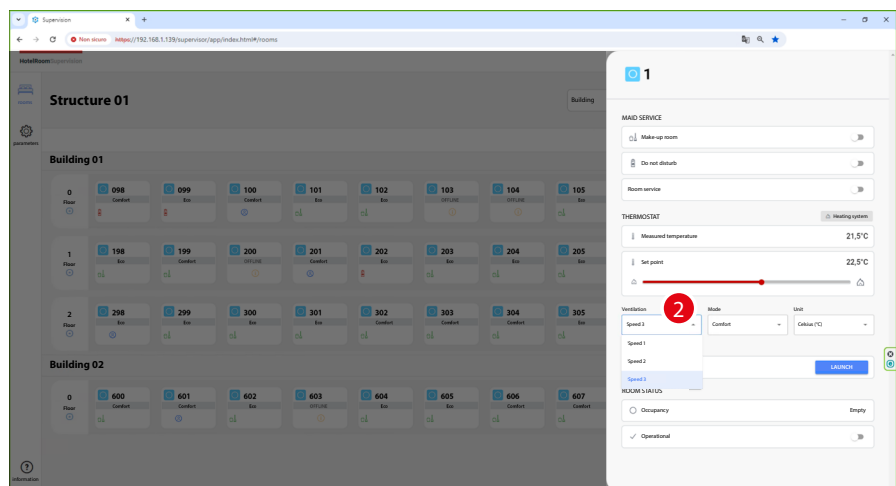

2. Click to select the fan speed: Speed 1, Speed 2 e Speed 3

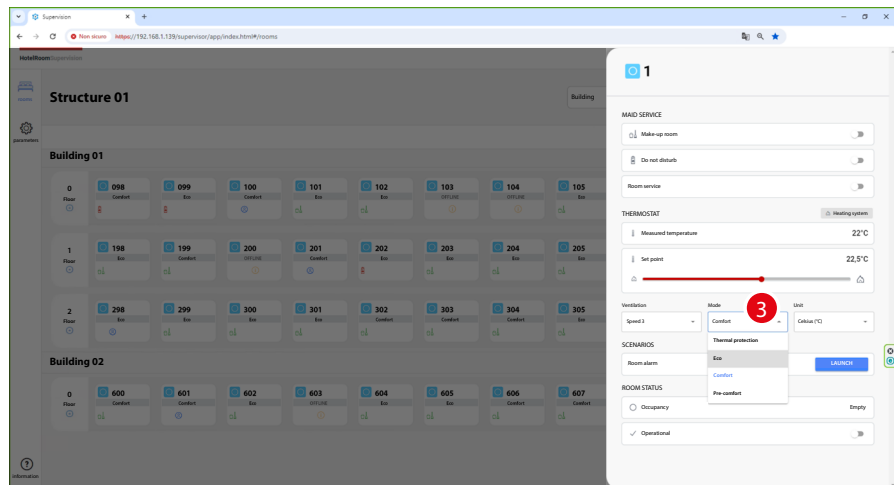

3. Click to select the temperature setpoint used by UXOne:

Thermal protection = temperature set when the room is not used for a long time (e.g. seasonal closure)

Eco = temperature set when no one is in the room

Comfort = temperature set when someone is in the room

Pre-comfort = temperature set a few hours before the room is occupied

NOTE: The **“Thermal protection/Eco/Pre-comfort”** temperature setpoint values are set by the installer, while the Comfort mode temperature can be **adjusted** using the Hotel Room Supervision software or UXOne.

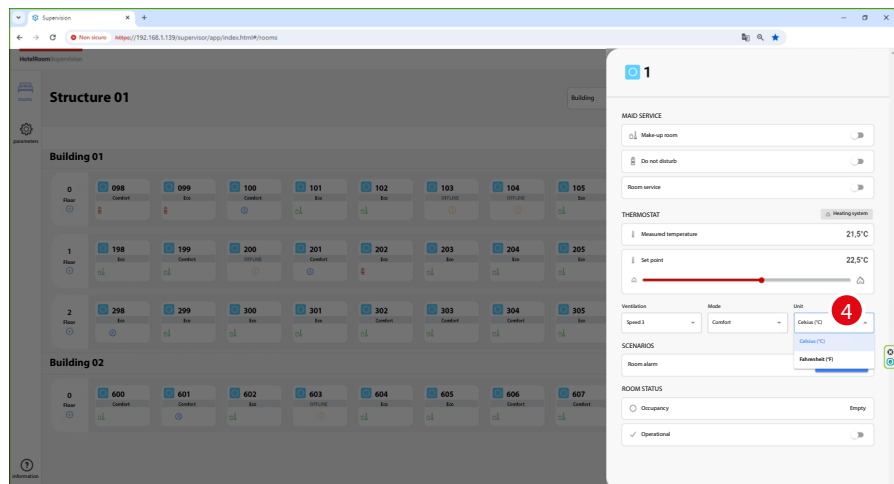

4. Click to select the measurement unit for the temperature (Celsius or Fahrenheit) shown on the thermostat.

Parameters

NOTE: This section only appears to the Administrator user

This section can be used to change certain settings related to the use of the Hotel Room Supervision software.

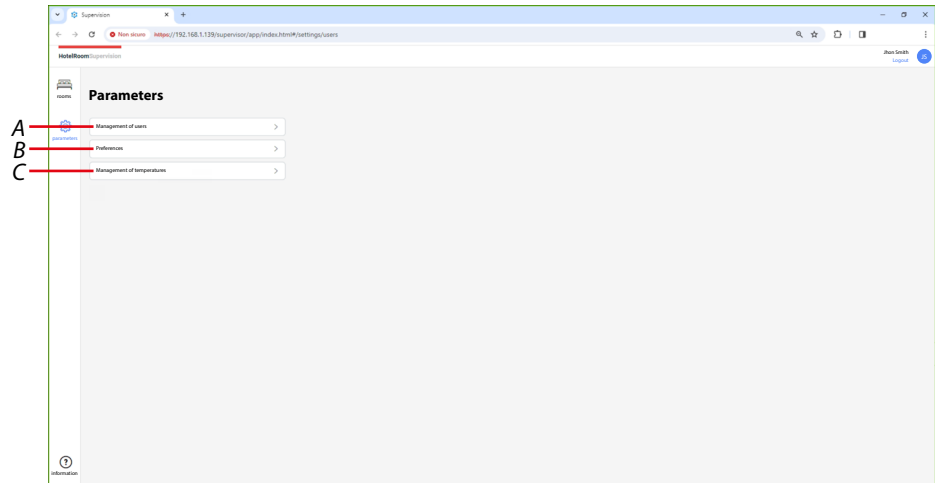

A [Management of users](#)

B [Preferences](#)

C [Management of temperatures](#)

Management of users

This section can be used to manage existing users or add new ones.

Users can be of 2 types: **Administratore** or **Staff**.

Staff users cannot use the functions in the "Parameters" section.

NOTE: There can be up to 99 **Staff** users, but only one **Administrator** user.

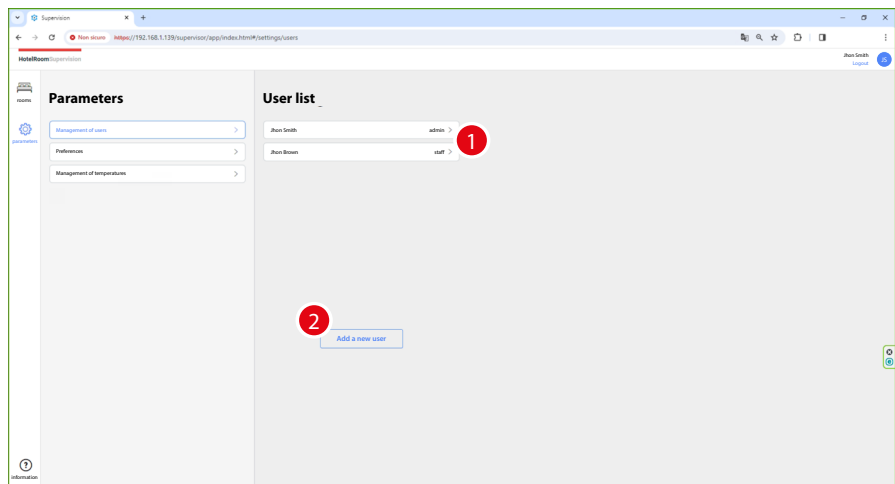

1. Click to manage the user.

or

2. Click to [add a new user](#).

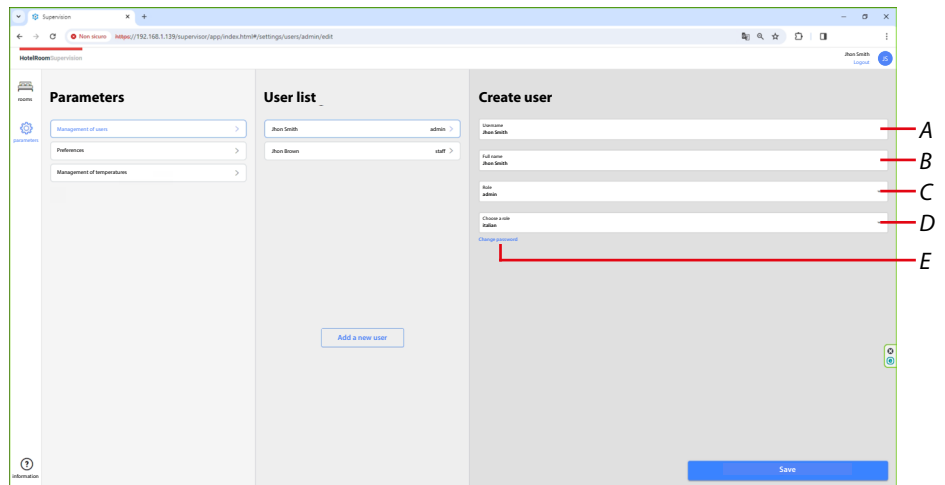

- A Display/edit the user name
- B Display/edit the full user name
- C View/select the role assigned to the user (Administrator or Staff)
- D View/select the Hotel Room Supervision language
- E **Change password**

Add a new user

This section can be used to add new Staff users, who will then be able to use Hotel Room Supervision.

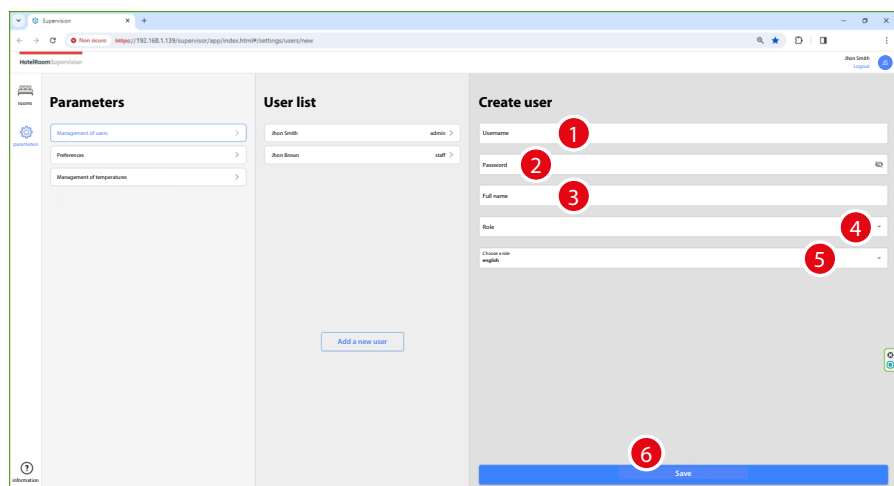

NOTE: At least one user must have the role of Administrator

1. Enter the user name.
2. Enter the password.
3. Enter the full user name.
4. Select the role to be assigned to the user (Administrator or Staff).
5. Select the language used by Hotel Room Supervision when interacting with the user
6. Click to record the created user

Delete a user

This section can be used to permanently delete a user

NOTE: A user with the role of Administrator cannot be deleted. It will be necessary to first change their role to Staff before deleting them.

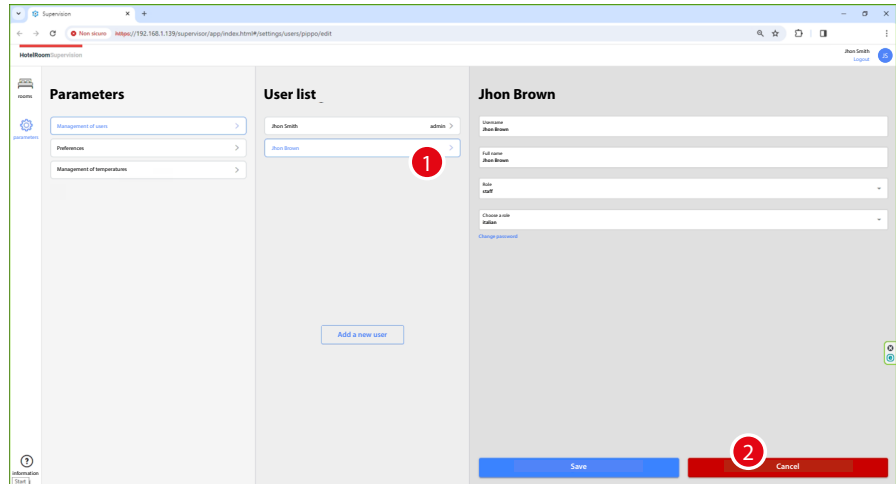

1. Select the user to be deleted.
2. Click to start the user deletion procedure.

A pop-up window will ask to enter a confirmation code for the deletion of the user

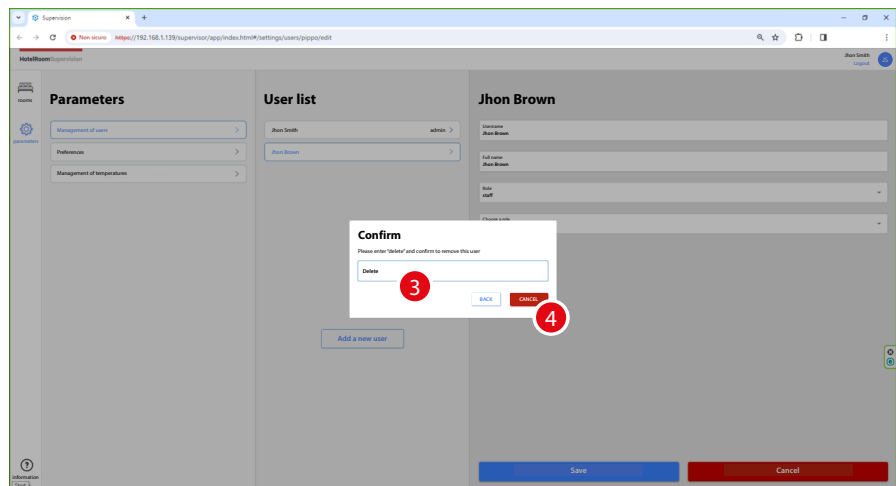

1. Enter the required code to delete the user.
NOTE: To make sure that the deletion is successful, pay attention to upper and lower cases.
2. Click to confirm.

The user has been correctly deleted.

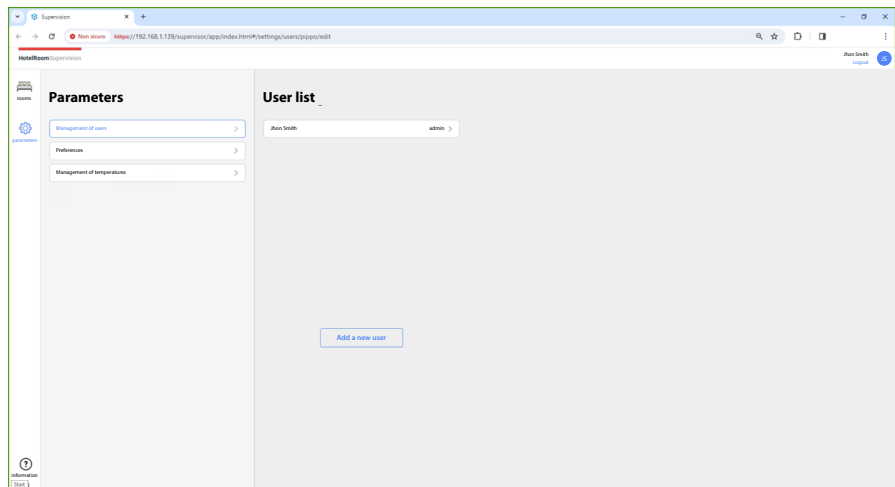

Change password

This section can be used to change your Hotel Room Supervision access password.

NOTE: For the Administrator user, it is actually a matter of adding a new password, as the default password (found on the server label) is always valid and cannot be changed.

E.g.: after the Administrator changes their password, for example setting "HotelRoom75%", as their personal password, they will be able to access Hotel Room Supervision with both **HotelRoom75%** and the default password found on the server label.

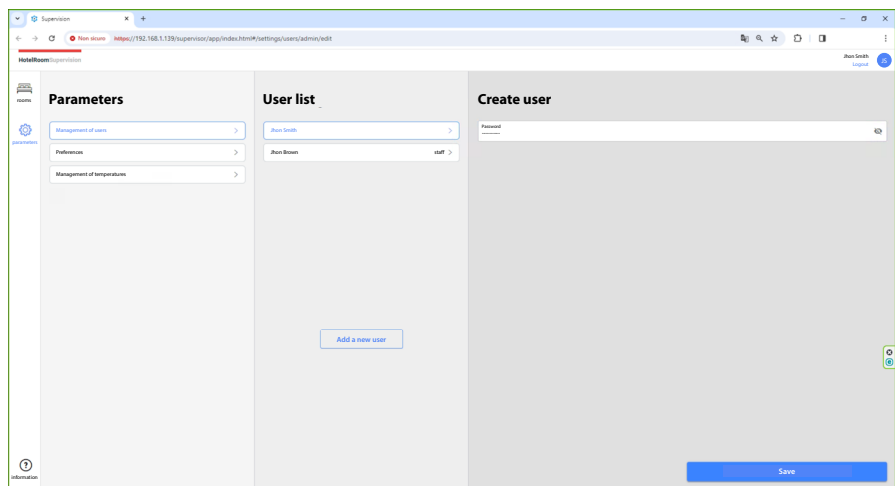

1. Select the user for which you want to change the password.
2. Enter the new password, which must meet the following requirements:
 - at least 8 characters;
 - at least one lower case letter (e.g. a);
 - at least one upper case letter (e.g. A);
 - at least one number (e.g. 1);
 - at least one special character (e.g. \$);
3. Click to record the new password.

Preferences

This section can be used to change certain preferences of Hotel Room Supervision.

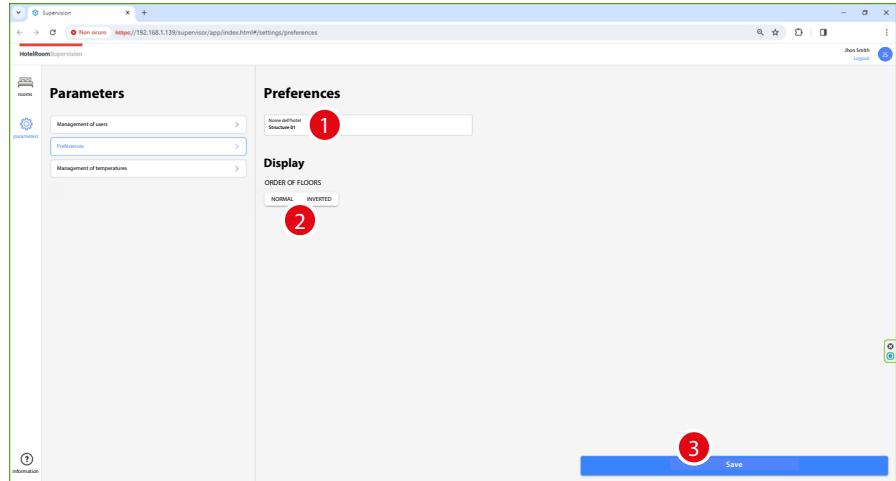

1. View/change the hotel name displayed on Hotel Room Supervision.
2. Select how the order of floors is displayed
Normal: e.g. from floor 1 to floor 6
Inverted: e.g. from floor 6 to floor 1
1. Click to record the settings

Management of temperatures

This section can be used to choose the temperature unit of measure: Celsius or Fahrenheit.

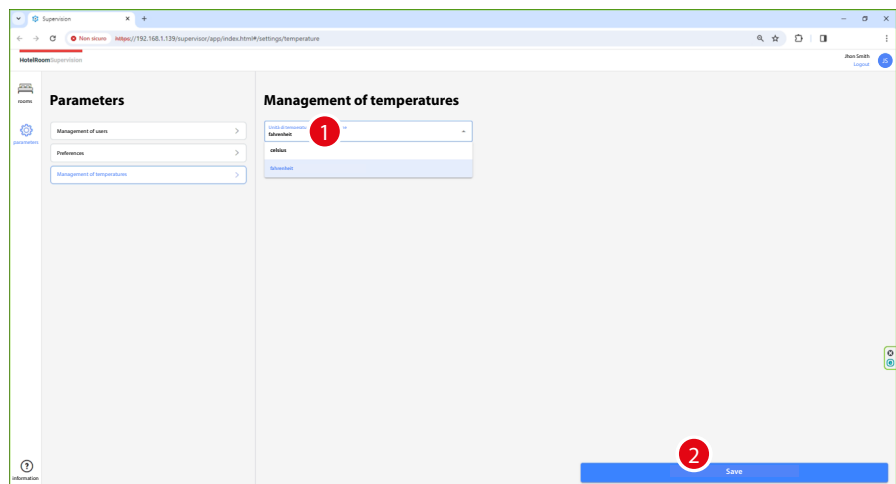

1. Select the measurement unit for the temperature (Celsius or Fahrenheit) shown on Hotel Room Supervision.
2. Click to record the settings

Information

This section shows the software version, legal notices and privacy policy.

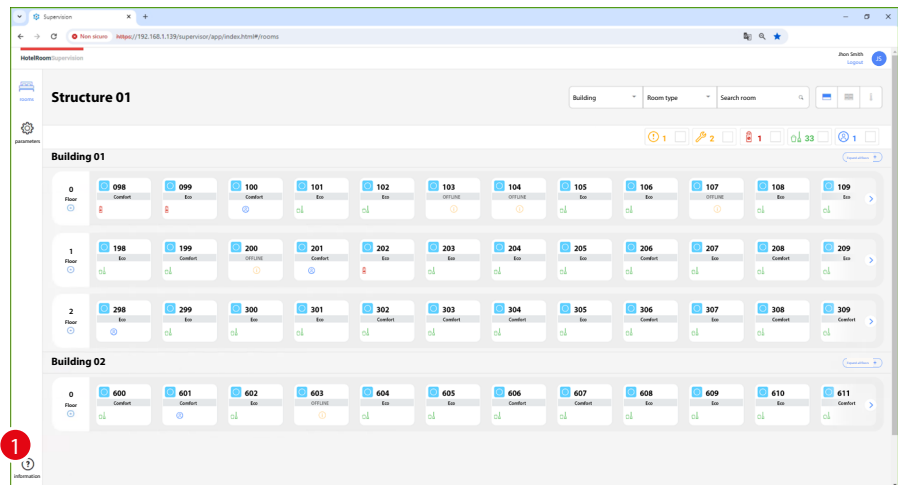

1. Click to open the section

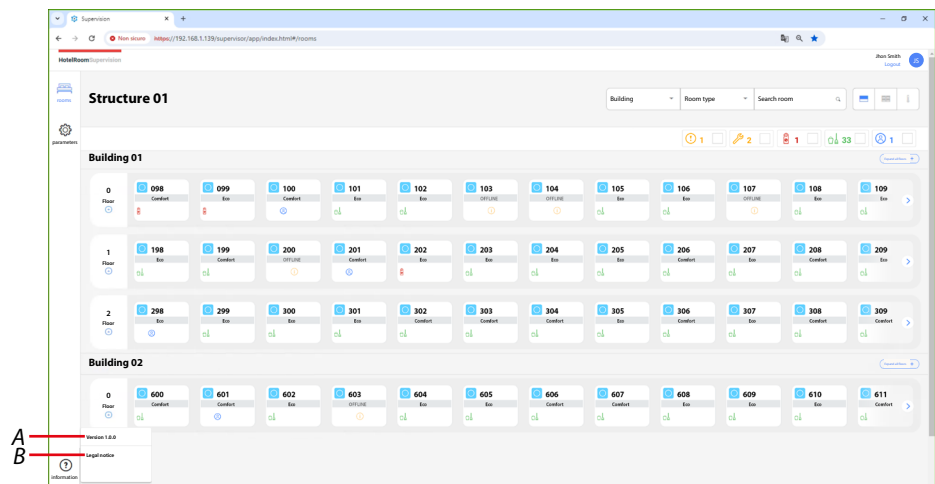

A Software version.

B [Legal notice](#)

Legal Notices

This section can be used to display the terms and conditions of use.

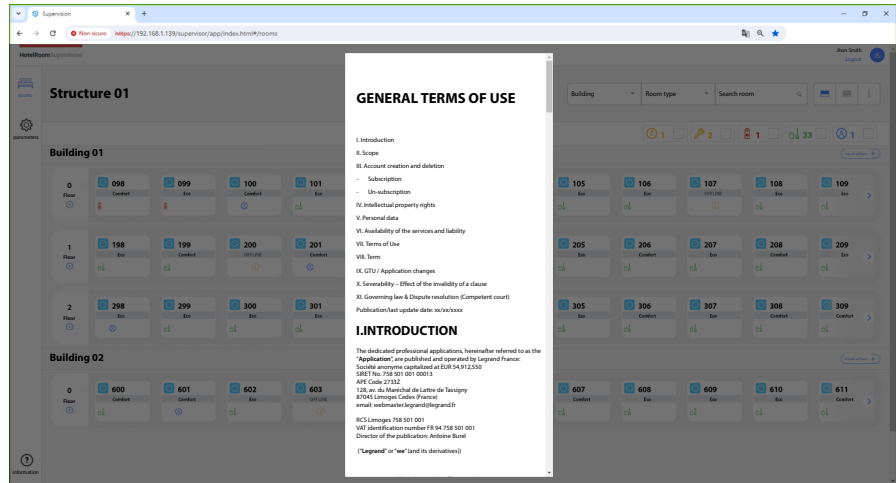

Logout

The logout procedure is used to disconnect from the account

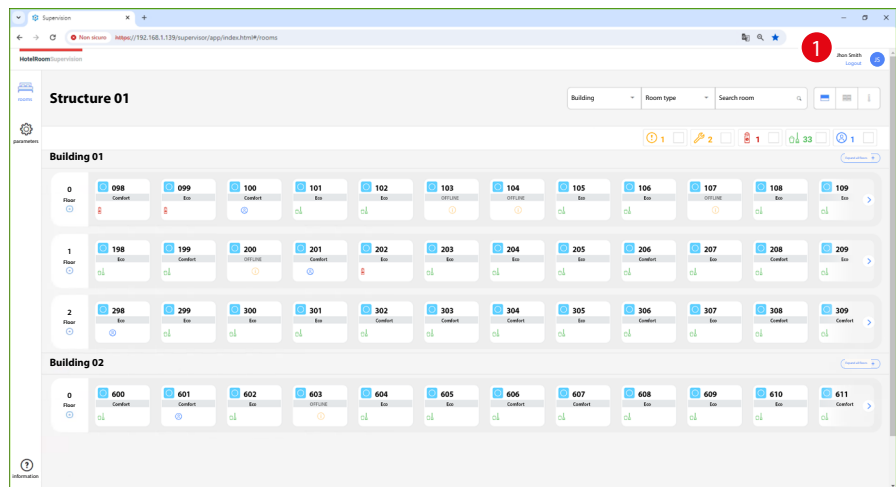

1. Click to logout, the **Authentication** page will be displayed

Manuale di utilizzo del termostato UXOne



Item 0 489 00/01/02/03/04/05/06/07

Hotel

Room n°

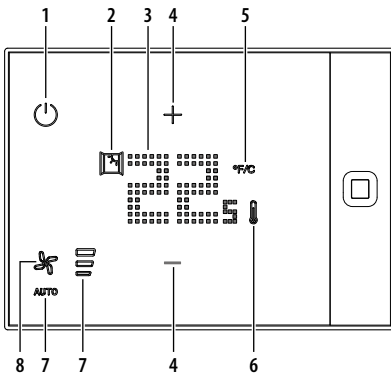

Icon	Function	Description
1	MODE key:	Press to switch the thermostat on/off
2	"Window open" icon	When on, it indicates that a sensor has detected the opening of a window and the temperature control system remains in stand-by until it is closed again.
3	Temperature indicator	When idle, it shows the measured temperature; during adjustment, it shows the set temperature.
4	Temperature adjustment keys	Press to adjust the temperature. ATTENTION: if they are not available, it means that the temperature has been set by reception and cannot be changed. Call reception if the temperature is not appropriate.
5	Key for temperature measurement unit selection	Press to select the temperature unit of measure: Celsius or Fahrenheit
6	Heating temperature control mode icon	When red, temperature control is set to heating
	Cooling temperature control mode icon	When blue, temperature control is set to cooling
7	Fan speed icons	It indicates the speed of the Fancoil (3 speeds available)
8	Fan adjustment key	Press to adjust the speed of the Fancoil (3 manual speeds plus automatic operation)

Adjust the temperature

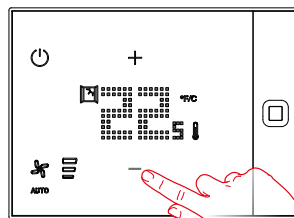

Touch+ or – to enable the modification

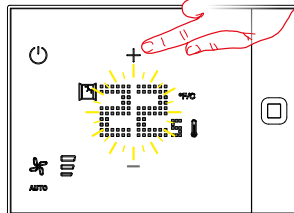

The temperature flashes, touch +/- to increase/decrease the temperature

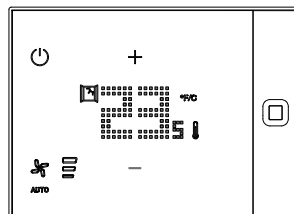

When flashing stops, the temperature is set



Manuale di utilizzo del termostato UXOne



Item 0 489 15/23/24/25/27/28/29/30

Hotel

Room n°

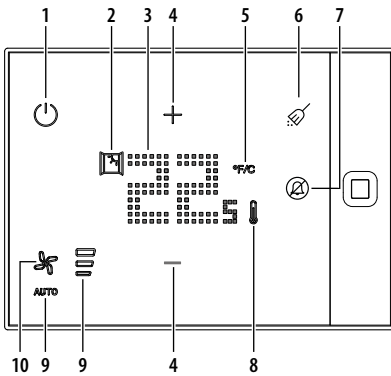

Icon	Function	Description
1	MODE key:	Press to switch the thermostat on/off
2	"Window open" icon	When on, it indicates that a sensor has detected the opening of a window and the temperature control system remains in stand-by until it is closed again.
3	Temperature indicator	When idle, it shows the measured temperature; during adjustment, it shows the set temperature. Press to adjust the temperature.
4	+ - Temperature adjustment keys	ATTENZIONE: if they are not available, it means that the temperature has been set by reception and cannot be changed. Call reception if the temperature is not appropriate.
5	Key for temperature measurement unit selection	Press to select the temperature unit of measure: Celsius or Fahrenheit
6	Make up room (MUR) key	Press to request room cleaning. When on, it indicates that room cleaning has been requested.
7	Do not disturb (DND) key	Press to request not to be disturbed. When on, it indicates that a request has been made not to disturb this room.
8	Heating temperature control mode icon	When red, temperature control is set to heating
	Cooling temperature control mode icon	When blue, temperature control is set to cooling
9	Fan speed icons	It indicates the speed of the Fancoil (3 speeds available)
10	Fan adjustment key	Press to adjust the speed of the Fancoil (3 manual speeds plus automatic operation)

Adjust the temperature

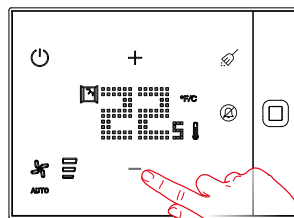

Touch+ or - to enable the modification

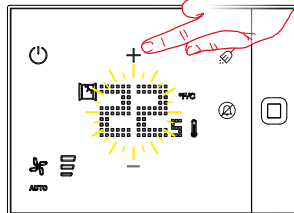

The temperature flashes, touch +/- to increase/decrease the temperature

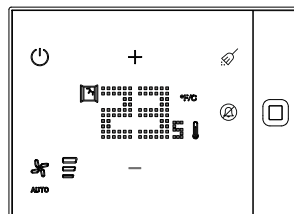

When flashing stops, the temperature is set



Manuale di utilizzo del termostato UXOne



Item 0 489 80/81/82/83

Hotel

Room n°

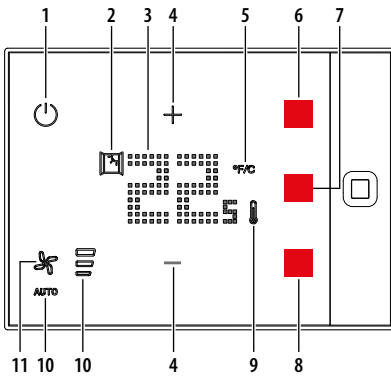

Icon	Function	Description
1	MODE key:	Press to switch the thermostat on/off
2	"Window open" icon	When on, it indicates that a sensor has detected the opening of a window and the temperature control system remains in stand-by until it is closed again.
3	Temperature indicator	When idle, it shows the measured temperature; during adjustment, it shows the set temperature. Press to adjust the temperature.
4	+ - Temperature adjustment keys	ATTENZIONE: if they are not available, it means that the temperature has been set by reception and cannot be changed. Call reception if the temperature is not appropriate.
5	Key for temperature measurement unit selection	Press to select the temperature unit of measure: Celsius or Fahrenheit
6	Key.....
7	Key.....
8	Key.....
9	Heating temperature control mode icon	When red, temperature control is set to heating
	Cooling temperature control mode icon	When blue, temperature control is set to cooling
10	Fan speed icons	It indicates the speed of the Fancoil (3 speeds available)
11	Fan adjustment key	Press to adjust the speed of the Fancoil (3 manual speeds plus automatic operation)

Adjust the temperature

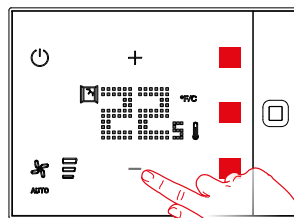

Touch+ or – to enable the modification

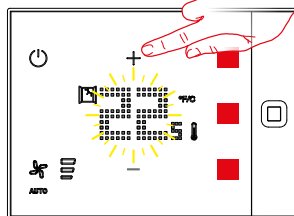

The temperature flashes, touch +/- to increase/decrease the temperature

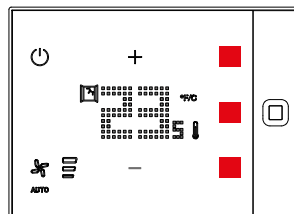

When flashing stops, the temperature is set



