

- Accessoires de raccordement
- Connection accessories
- Anschluß-Zubehör
- Accesorios de conexión
- Accessori di collegamento
- Acessórios de ligação
- εξαρτήματα σύνδεσης
- Wyposażenie przyłączeniowe
- Bağlantı aksesuarları

DPX 630

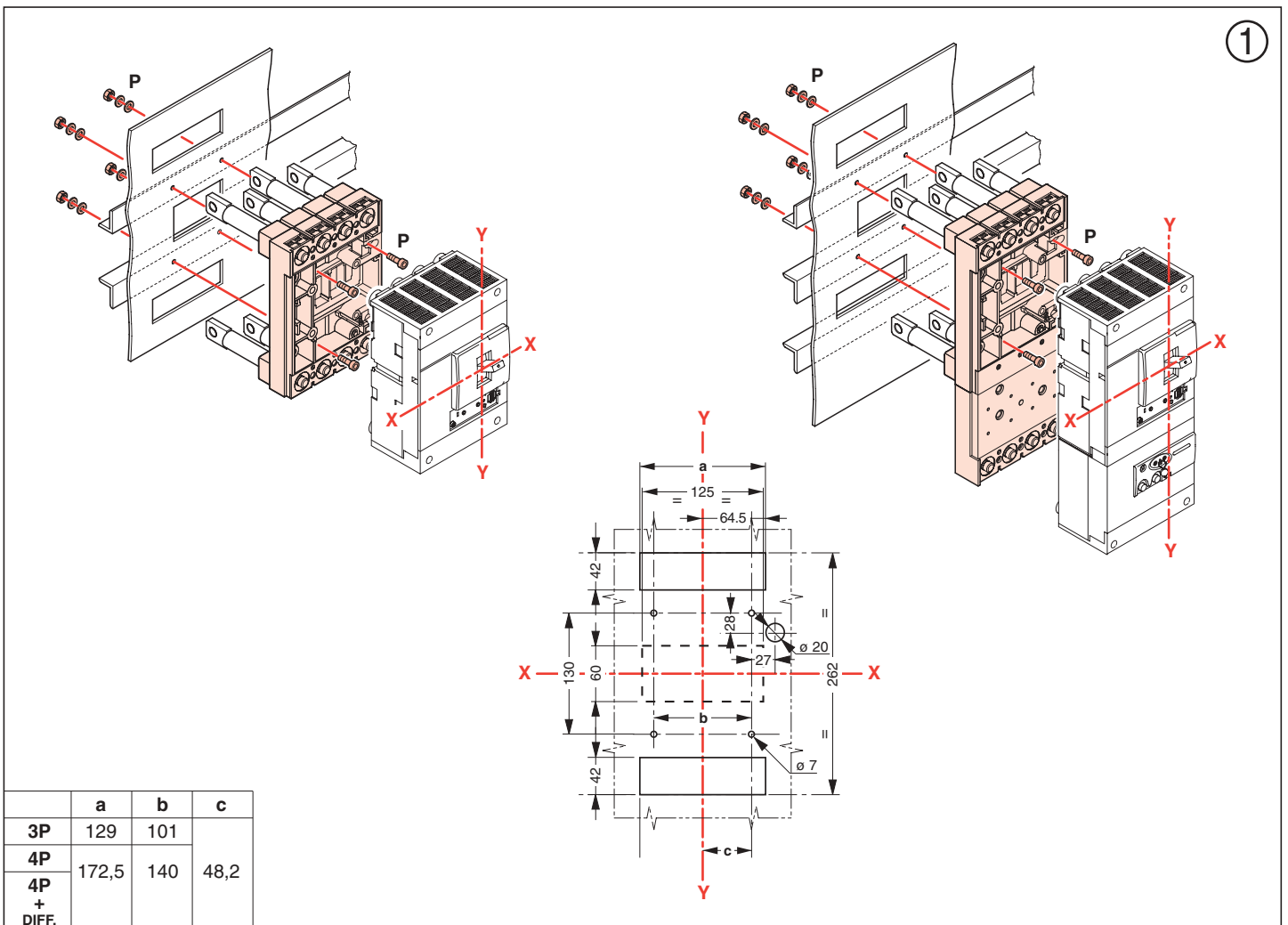

1

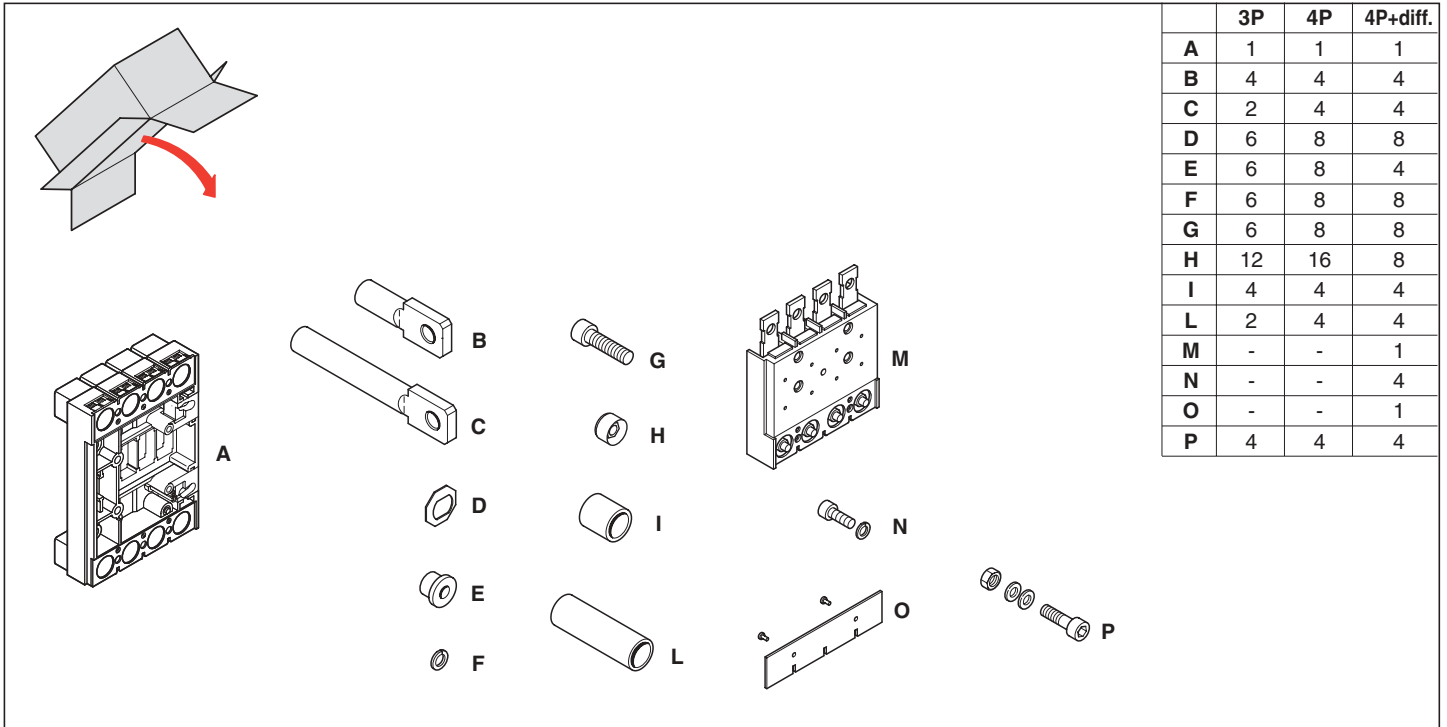
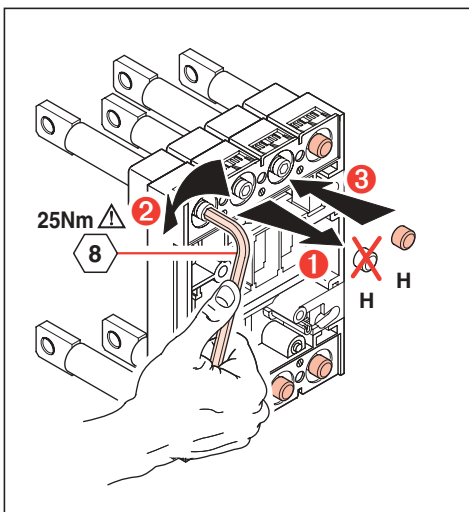
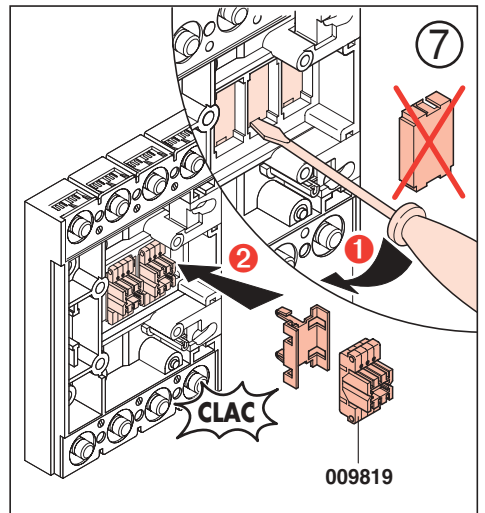
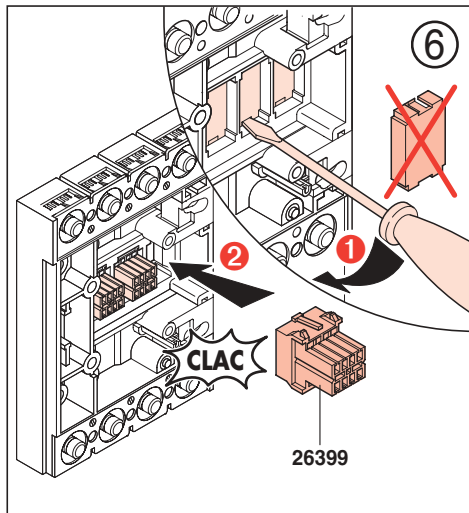
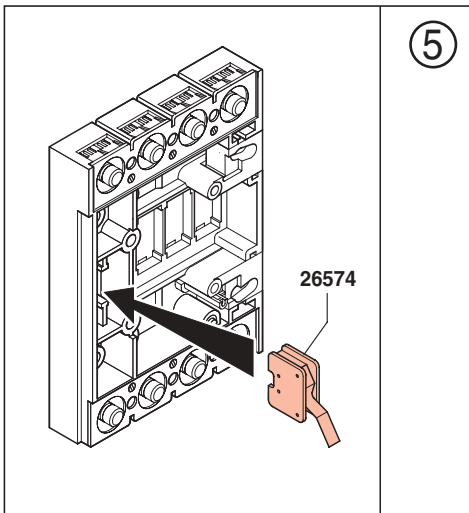
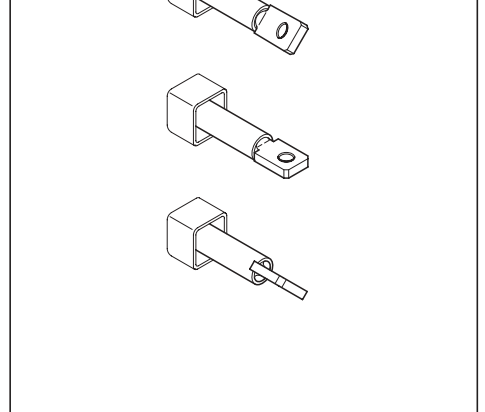
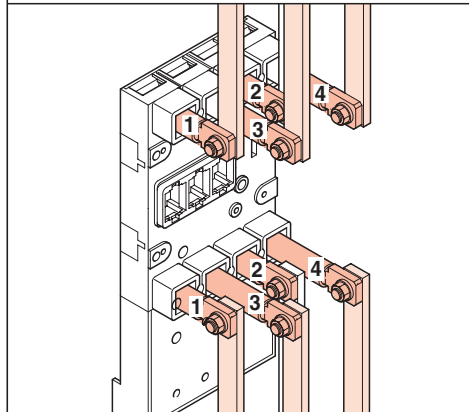
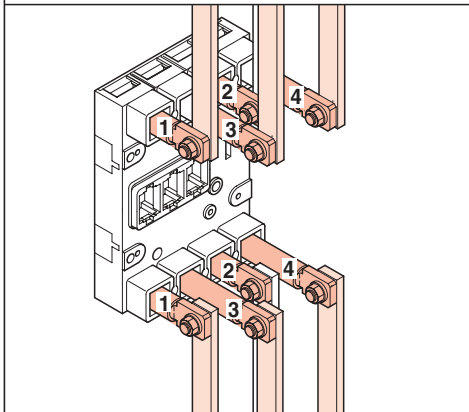
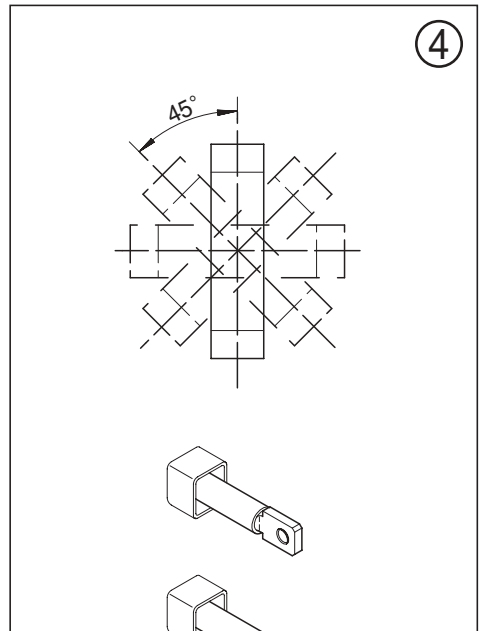
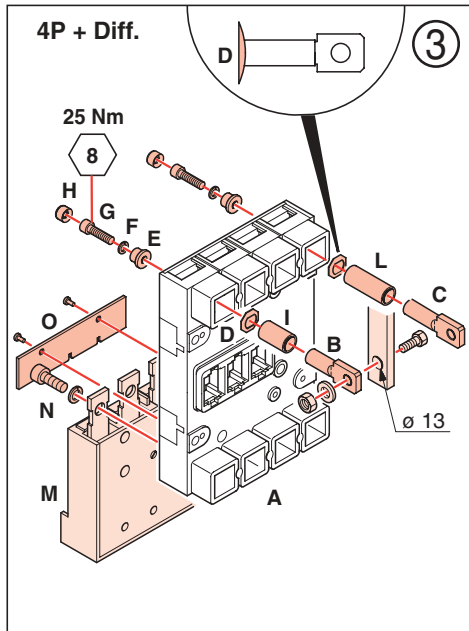
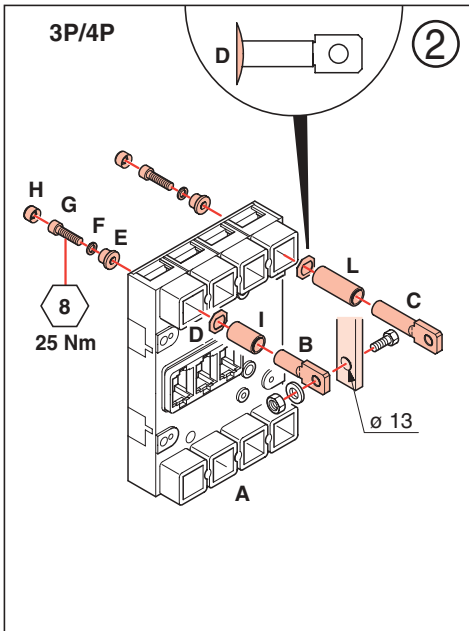

Pour la maintenance : enlever les protections H ;
verifier le couple de serrage 25Nm ; mettre les nouvelles protections H .

For maintenance purposes: remove the covers H;
insert new covers H.

Zur Wartung: Stopfen H entfernen; Anzugsmoment prüfen, muss 25Nm sein;
neue Stopfen H einführen.

Mantenimiento: extraer los tapones H; verificar que el par de apriete sea de 25Nm;
insertar los nuevos tapones H.

Per manutenzione: rimuovere i tappi H; verificare coppia di serraggio 25Nm;
inserirne i nuovi tappi H.