

This pack is a connected accessory which **requires** you to buy and install the connected starter pack and Niloé Step with Netatmo connected power outlets, switches (with dimmer option) and/or connected lighting micromodules first.

This product controls only Niloé Step with Netatmo connected switches (with dimmer option), lighting micromodules and power outlets.

Pack contents

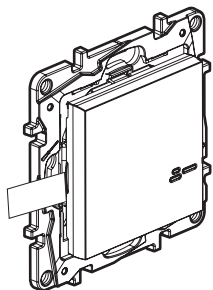

Wireless lighting switch



Removable stickers

Frequency bands: 2.4 - 2.4835 GHz
Power level: < 100 mW



www.legrand.com

LEGRAND - Pro and Consumer Service - BP 30076
87002 LIMOGES CEDEX FRANCE • www.legrand.com

LE13857AA

Installing the wireless lighting control

To pair the wireless control for lights and electrical devices with your connected installation, you should follow the instructions:

- in the **user guide in your connected starter pack**
- in the **Legrand Home + Control application (Settings/Add a new product section)**
- or consult the user manual on legrand.com

Replacing the battery

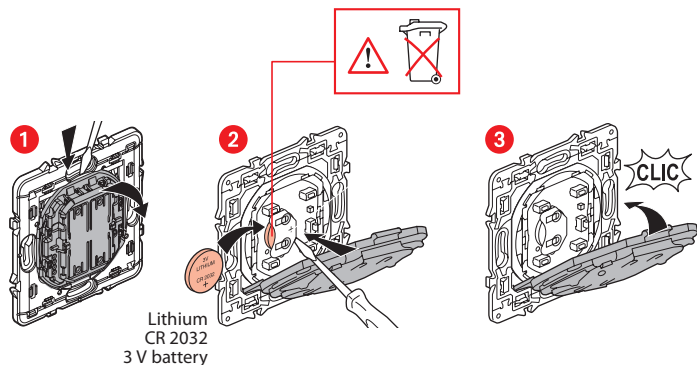

SIMPLIFIED EU DECLARATION OF CONFORMITY

The undersigned,

Legrand

declares that the radio-electric equipment referred to in these instructions complies with directive 2014/53/EU.

The full text of the EU declaration of conformity is available on the following website :

www.legrand.com/ecatalogue