

Wake up/Sleep wireless switch  
8 636 01 - 8 637 01 - 8 638 01 - 8 639 01

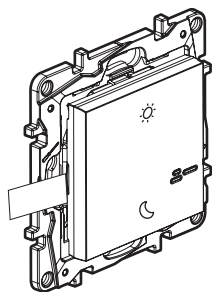

This pack is a connected accessory which **requires** you to buy and install the connected starter pack and Niloé Step with Netatmo power outlets, switches and/or connected lighting micromodules first.

### Pack contents



Wake up/Sleep  
wireless switch



Removable stickers

Frequency bands: 2.4 - 2.4835 GHz  
Power level: < 100 mW



[www.legrand.com](http://www.legrand.com)

LEGRAND - Pro and Consumer Service - BP 30076  
87002 LIMOGES CEDEX FRANCE • [www.legrand.com](http://www.legrand.com)

LE13852AA

### Install the Wake up/Sleep wireless switch

To add the Wake up/Sleep wireless switch to your connected installation, you should follow the instructions:

- in the **Legrand Home + Control application (Settings/Add a new product section)**
- or consult the user manual on [legrand.com](http://legrand.com)

### Replacing the battery

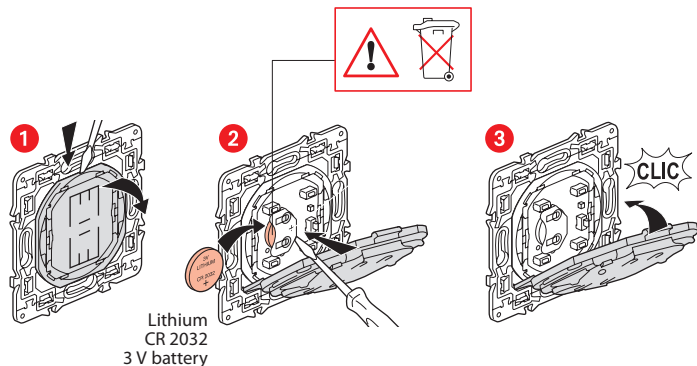

### SIMPLIFIED EU DECLARATION OF CONFORMITY

The undersigned,

**Legrand**

declares that the radio-electric equipment referred to in these instructions complies with directive 2014/53/EU.

The full text of the EU declaration of conformity is available on the following website:

[www.legrand.com/ecatalogue](http://www.legrand.com/ecatalogue)