





Sommario

Pericoli e avvertenze	4
Operazioni preliminari	6
Presentazione	7
Installazione	8
Utilizzo	11
Programmazione	18
Comunicazione	21
Sequenza di collegamento	22
Caratteristiche tecniche	23

Contents

<i>Dangers and warnings</i>	4
<i>Preliminary operations</i>	6
<i>Presentation</i>	7
<i>Installation</i>	8
<i>Use</i>	11
<i>Programming</i>	18
<i>Communication</i>	21
<i>Connection sequence</i>	22
<i>Technical characteristics</i>	26

Sommaire

Danger et avertissement	4
Opérations préalables	6
Présentation	7
Installation	8
Utilisation	11
Programmation	18
Communication	21
Séquence de connexion	22
Caractéristiques techniques	29

Summary

<i>Gefahren und Warnungen</i>	5
<i>Vorarbeiten</i>	6
<i>Presentation</i>	7
<i>Installieren</i>	8
<i>Verwendung</i>	11
<i>Programmierung</i>	18
<i>Kommunikation</i>	21
<i>Verbindungssequenz</i>	22
<i>Technische Daten</i>	32

Resumida

Advertencia	5
Operaciones previas	6
Presentación	7
Instalación	8
Utilización Programación	11
Programación	18
Comunicación	21
Secuencia de conexión	22
Características técnicas	35

• Pericoli e avvertenze

Questo apparecchio deve essere montato esclusivamente da professionisti.
Il mancato rispetto delle indicazioni contenute nelle presenti istruzioni solleva il fabbricante da ogni responsabilità.

Rischi di folgorazione, ustioni o esplosione

- L'installazione e la manutenzione di questo apparecchio devono essere effettuate esclusivamente da personale qualificato.
 - Prima di qualsiasi intervento sull'apparecchio, escludere gli ingressi di tensione.
 - Utilizzare sempre un opportuno dispositivo di rilevamento di tensione per confermare l'assenza di tensione.
 - Rimontare tutti i dispositivi, i portelli e i coperchi prima di mettere l'apparecchio sotto tensione.
 - Per alimentare questo apparecchio, utilizzare sempre la tensione nominale indicata.
- In caso di mancato rispetto di queste precauzioni, si potrebbero subire gravi ferite.

Rischi di deterioramento dell'apparecchio

Attenzione a rispettare:

- Una tensione ai morsetti degli ingressi di tensione (L1,L2,L3 e N) secondo i valori indicati nella sezione "Caratteristiche tecniche".
- La frequenza di rete a 50 o 60 Hz.

• Dangers and warnings

This equipment must only be mounted by professionals.

The manufacturer shall not be held responsible for failure to comply with the instructions in this manual.

Risk of electrocution, burns or explosion

- *The device must only be installed and serviced by qualified personnel.*
 - *Prior to any work on or in the device, isolate the voltage inputs.*
 - *Always use an appropriate voltage detection device to confirm the absence of voltage.*
 - *Put all mechanisms, door and covers back in place before energising the device.*
 - *Always supply the device with the indicated rated voltage.*
- Failure to take these precautions could cause serious injuries.*

Risk of damaging the device

Chek the following:

- *The voltage to the voltage-input terminals, (L1,L2,L3 and N) according to the values indicated in the "Technical characteristics" section.*
- *The frequency of the distribution system (50 or 60 Hz).*

• Danger et avertissement

Le montage de ce produit ne peut être effectué que par des professionnels.

Le non respect des indications de la présente notice ne saurait engager la responsabilité du constructeur.

Risque d'électrocution, de brûlures ou d'explosion

- L'installation et l'entretien de cet appareil ne doivent être effectués que par du personnel qualifié.
 - Avant toute intervention sur l'appareil, coupez les entrées tensions.
 - Utilisez toujours un dispositif de détection de tension approprié pour confirmer l'absence de tension.
 - Remplacez tous les dispositifs, les portes et les couvercles avant de mettre cet appareil sous tension.
 - Utilisez toujours la tension assignée appropriée pour alimenter cet appareil.
- Si ces précautions n'étaient pas respectées, cela pourrait entraîner des blessures graves.

Risque de détérioration de l'appareil

Veillez à respecter

- Une tension aux bornes des entrées tensions (L1,L2,L3 et N) selon les valeurs indiquées dans la section "Caractéristiques techniques".
- La plage de fréquence du réseau 50 ou 60 Hz.

• Gefahren und Warnungen

Das Gerät darf nur von Fachleuten montiert werden.

Die Nichtbeachtung der vorliegenden Anweisungen entbindet den Hersteller von jeglicher Haftung.

Stromschlag-, Verbrennungs- und Explosionsgefahr

- Die Installation und Wartung dürfen nur von qualifizierten Fachleuten vorgenommen werden.
 - Vor jedem Eingriff in das Gerät sind die Spannungseingänge auszuschließen.
 - Verwenden Sie immer ein geeignetes Spannungsmessgerät, um die Spannungsfreiheit zu überprüfen.
 - Alle Geräte, Türen und Abdeckungen wieder montieren, bevor Sie das Gerät unter Spannung setzen.
 - Verwenden Sie immer die angegebene Nennspannung, um das Gerät mit Strom zu versorgen.
- Die Nichtbeachtung dieser Vorsichtsmaßnahmen kann zu schweren Verletzungen führen.*

Beschädigungsgefahr des Gerätes

Bitte beachten:

- Eine Spannung an den Klemmen der Spannungseingänge (L1, L2, L3 und N) entsprechend den im Kapitel "Technische Daten" angegebenen Werten.
- Netzfrequenz 50/60 Hz

• Advertencia

El montaje de este material sólo puede ser efectuado por profesionales.

No respetar las indicaciones del presente manual exime de responsabilidad al fabricante.

Riesgo de electrocución, de quemaduras o de explosión

- La instalación y mantenimiento de este aparato debe ser efectuado por personal cualificado.
- Antes de cualquier intervención en el aparato, cortar sus entradas de tensión.
- Utilizar siempre un dispositivo de detección de tensión apropiado para asegurar la ausencia de tensión.
- Volver a colocar todos los dispositivos, tapas y puertas antes de poner el aparato en tensión.
- Utilizar siempre la tensión asignada apropiada para alimentar el aparato.

No respetar estas precauciones podría entrañar un serio riesgo de producir heridas graves.

Riesgo de deterioros de aparato

Se ha de respetar:

- Una tensión en los bornes de las entradas de tensión (L1, L2, L3 y N) según los valores indicados en la sección "Características técnicas".
- La frecuencia de red a 50/60 Hz

• Operazioni preliminari

Per la sicurezza del personale e del materiale, è indispensabile leggere attentamente il contenuto del presente libretto prima della messa in servizio.

Al momento del ricevimento della scatola contenente il dispositivo, è necessario verificare i seguenti punti:

- lo stato dell'imballo;
- l'assenza di danneggiamenti o rotture dovuti al trasporto;
- la rispondenza tra codice dell'apparecchio e codice ordinato;
- la presenza nell'imballo sia dell'articolo che del foglio istruzioni.

• Preliminary operations

For personnel and product safety read the contents of these operating instructions carefully before connecting.

Check the following points as soon as you receive the box containing the device:

- *the packing is in good condition;*
- *the product has not been damaged or broken during transport;*
- *the product reference number conforms to your order;*
- *the package contains both the item and the operating instructions.*

• Opérations préalables

Pour la sécurité du personnel et du matériel, il est impératif de bien s'imprégner du contenu de cette notice avant la mise en service.

Au moment de la réception du colis contenant le produit, il est nécessaire de vérifier les points suivants :

- l'état de l'emballage ;
- le produit n'a pas eu de dommage pendant le transport ;
- la référence de l'appareil est conforme à votre commande
- l'emballage comprend le produit ;
- une notice d'utilisation.

• Vorarbeiten

Für die Sicherheit von Personen und Material ist es unerlässlich, den Inhalt dieser Anleitung vor der Inbetriebnahme aufmerksam zu lesen. Nach Erhalt der Schachtel mit dem Gerät sind die folgenden Punkte zu überprüfen:

- *Zustand der Verpackung;*
- *Das Fehlen von Beschädigungen oder Bruch durch den Transport;*
- *die Übereinstimmung zwischen Gerätecode und bestelltem Code;*
- *Vorhandensein in der Verpackung sowohl des Artikels als auch der Gebrauchsanweisung.*

• Operaciones previas

Para la seguridad del personal y del material, será imperativo conocer perfectamente el contenido de este manual antes de su puesta en funcionamiento.

Al recibir el paquete que contiene el producto será necesario verificar los aspectos siguientes:

- estado del embalaje;
- que el producto no se haya dañado durante el transporte;
- que la referencia del aparato esté conforme con su pedido;
- el embalaje incluye el producto;
- el manual de utilización.

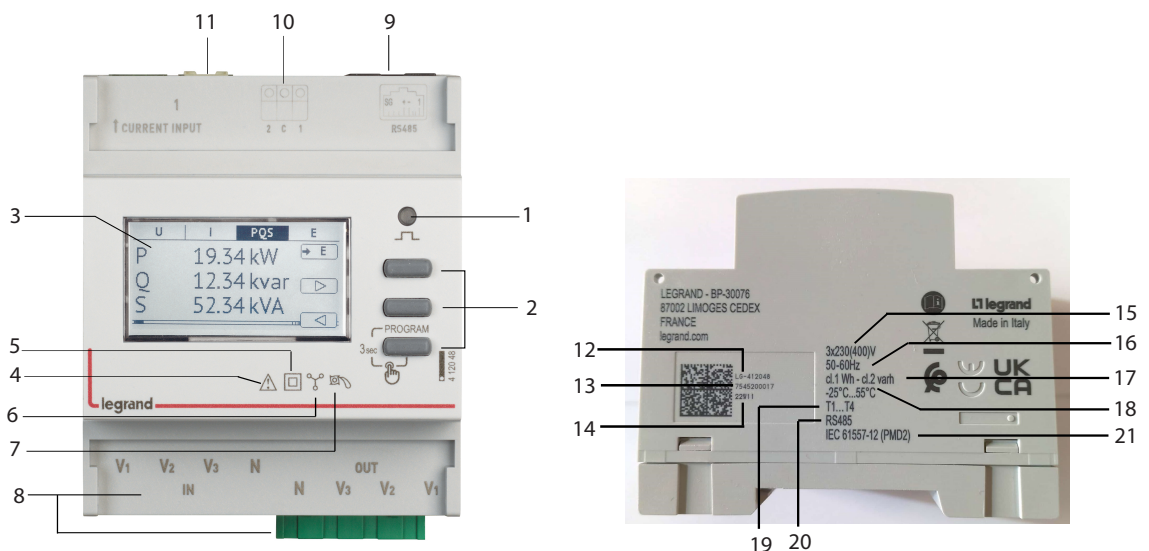

• **Presentazione**

1. LED metrologico
2. Tastiera a 3 pulsanti multifunzionali
3. Display grafico
4. Consultare manuale d'uso prima dell'installazione
5. Doppio isolamento
6. Inserzione su linea trifase 4 fili / 3 fili
7. Dispositivo antirotazione (antidecremento)
8. Tensioni
9. Connessione RJ45 per Modbus RTU
10. Ingresso tariffario
11. Ingresso correnti 1
12. Codice articolo
13. Datamatrix per tracciabilità prodotto
14. Settimana e anno di fabbricazione
15. Tensione
16. Tensioni nominali
17. Frequenze nominali
18. Classi di precisione
19. Temperatura d'impiego
20. Ingressi / Uscite
21. Norme di riferimento

• **Presentation**

1. *Metrological LED*
2. *Keypad with 3 multifunctional buttons*
3. *Graphic display*
4. *Consult the user manual before installation*
5. *Double insulation*
6. *Insertion on a three-phase 4-wire / 3-wire line*
7. *Anti-rotation device (anti-decrement)*
8. *Tensions*
9. *RJ45 connection for Modbus RTU*
10. *Tariff entry*
11. *Current input 1*
12. *Item code*
13. *Datamatrix for product traceability*
14. *Week and year of manufacture*
15. *Voltage*
16. *Nominal voltages*
17. *Nominal frequencies*
18. *Classes of accuracy*
19. *Operating temperature*
20. *Inputs / Outputs*
21. *Reference stan*

• **Présentation**

1. LED métrologique
2. Clavier constitué 3 boutons multifonctions
3. Écran graphique
4. Consulter le manuel d'utilisation avant de procéder à l'installation.
5. Double isolation
6. Insertion sur une ligne triphasée 4 fils / 3 fils
7. Dispositif anti-rotation (anti-décrémentation)
8. Tensions
9. Connexion RJ45 pour Modbus RTU
10. Entrée tarifaire
11. Entrée de courant
12. Code article
13. Datamatrix pour la traçabilité des produits
14. Semaine et année de fabrication
15. Tension
16. Tensions nominales
17. Fréquences nominales
18. Classes de précision
19. Température de fonctionnement
20. Entrées / Sorties
21. Normes de référence

• **Presentation**

1. *Metrologische LED*
2. *Tastatur mit 3 Multifunktionstasten*
3. *Graphisches Display*
4. *Bitte lesen das Handbuch bevor den Einbau*
5. *Doppelisolierung*
6. *Einstecken in eine dreiphasige 4-Draht / 3-Draht-Leitung*
7. *Antirotationsvorrichtung (Anti-Dekrement)*
8. *Spannungen*
9. *RJ45-Anschluss für Modbus RTU*
10. *Tarifeintrag*
11. *Stromeingang 1*
12. *Artikelcode*
13. *Datamatrix für die Rückverfolgbarkeit von Produkten*
14. *Woche und Jahr der Herstellung*
15. *Spannung*
16. *Nennspannungen*
17. *Nennfrequenzen*
18. *Genauigkeitsklassen*
19. *Betriebstemperatur*
20. *Eingänge/ Ausgänge*
21. *Referenzstandards*

• **Presentación**

1. LED metrológico
2. Teclado con 3 botones multifuncionales
3. Display gráfica
4. Consultar el manual de uso antes de la instalación
5. Doble aislamiento
6. Inserción en una línea trifásica de 4/3 hilos
7. Dispositivo anti-rotación (anti-decremento)
8. Tensiones
9. Conexión RJ45 para Modbus RTU
10. Entrada de tarifas
11. Entrada de corriente 1
12. Código de artículo
13. Datamatrix para la trazabilidad del producto
14. Semana y año de fabricación
15. Voltaje
16. Voltajes nominales
17. Frecuencias nominales
18. Clases de precisión
19. Temperatura de funcionamiento
20. Entradas / Salidas
21. Normas de referencia

• Installazione • Installation • Installation • Installieren • Instalación

• Prescrizioni

- Evitare la vicinanza con sistemi generatori di perturbazioni elettromagnetiche.

• Recommendations

- Avoid proximity to systems which generate electromagnetic interference.

• Recommendations

- Éviter la proximité avec des systèmes générateurs de perturbations électromagnétiques

• Rezepte

- Nähe zu Generatorsystemen vermeiden elektromagnetische Störungen.

• Prescripciones

- Evitar la proximidad con sistemas que generan interferencias electromagnéticas.

• Collegamento

Per la coppia di serraggio massima dei morsetti vedere la tabella

• Connection

For the maximum terminal torque see the table

• Raccordement







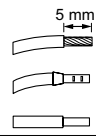

Pour le couple de serrage maximal des bornes voir le tableau

• Anschluss

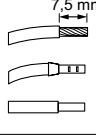
Das maximale Anzugsmoment der Klemmen finden Sie in der Tabell

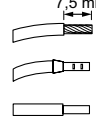
• Conexión

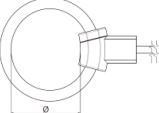
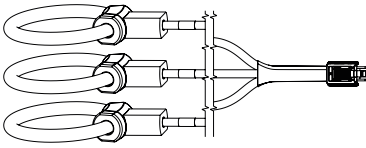
Para el par de apriete máximo de los bornes, consultar la tabla

U	3x230V / 3x400V ±15%	CAT III
COM	RS485 Modbus	
1 C 2	 <p>5 mm MAX 1 x 1mm² 1 x 1mm² 1 x 1mm²</p>	<p>Recommended torque 0,2Nm 0,5 x 3mm</p> 
V1-V2-V3-N 2 5 8 11	 <p>7,5 mm MAX 1 x 1,5mm² 1 x 2,5mm² 1 x 1,5mm²</p>	<p>Recommended torque 0,5Nm 0,5 x 3,5mm COMBI PH1</p> 
N-V3-V2-V1	 <p>7,5 mm MAX 1 x 1,5mm² 1 x 2,5mm² 1 x 1,5mm²</p>	<p>Recommended torque 0,5Nm 0,5 x 3,5mm</p> 
LED	<p>4 121 08: 630A 10 Wh/imp 4 121 09: 1600A 25 Wh/imp 4 121 10: 3200A 50 Wh/imp 4 121 11: 6300A 100 Wh/imp</p>	
	<p>4 121 08: I_{min} = 12,5A I_{ref} = 250A I_{max} = 750A 4 121 09: I_{min} = 32,5A I_{ref} = 650A I_{max} = 1950A 4 121 10: I_{min} = 65A I_{ref} = 1300A I_{max} = 3900A 4 121 11: I_{min} = 125A I_{ref} = 2500A I_{max} = 7500A</p>  <p>4 121 08: Ø 50 mm 4 121 09: Ø 100 mm 4 121 10: Ø 150 mm 4 121 11: Ø 240 mm</p> 	
cl.	<p>Wh(E_s):1 (IEC/EN 62053-21) varh(E_v):2 (IEC/EN 62053-23)</p>	
	<p>(-20°C) - (60°C)</p> 	

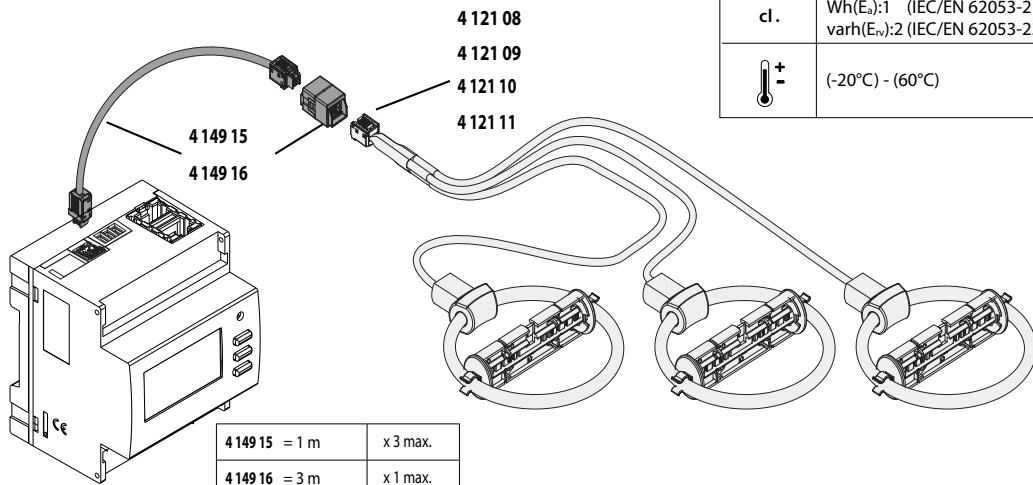

• Installazione • Installation • Installation • Installieren • Instalación

• Schema di collegamento • Wiring diagram • Schéma de câblage • Anschlussbilder
• Esquema de conexión

- Nei cablaggi rispettare scrupolosamente lo schema di inserzione; una inesattezza nei collegamenti può pregiudicare il corretto funzionamento o causare danni allo strumento.
- During wiring carefully comply with the connection diagram; a connection error may affect proper operation, or cause damage to the device.
- Veuillez respecter scrupuleusement le schéma de connexion; une erreur de connexion peut nuire au bon fonctionnement, ou causer des dommages à l'appareil.
- Beachten Sie bei der Verdrahtung unbedingt das Anschlusschema; Ungenauigkeiten in den Anschlüssen können zu Fehlbedienungen oder Schäden am Gerät führen.
- En los cableados, se ha de respetar rigurosamente el esquema de inserción; si las conexiones no son precisas, se puede perjudicar el funcionamiento correcto o causar daños al instrumento.

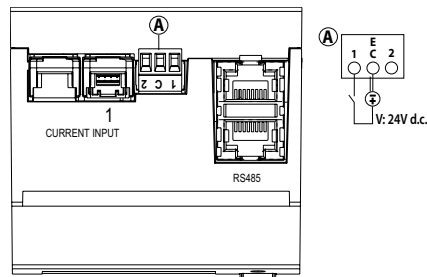

• Marcature uscite comunicazione e ingressi tariffari

- Marking of communication outputs and tariff entrances
- Marquage des sorties de communication et des entrées tarifaires
- Kennzeichnung von Kommunikationsausgaben und Tarifeintritten
- Marcado de salidas de comunicación y entradas de tarifas

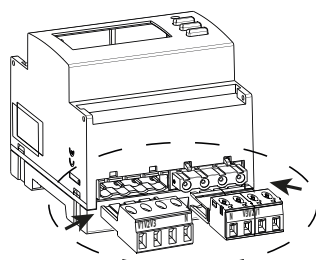
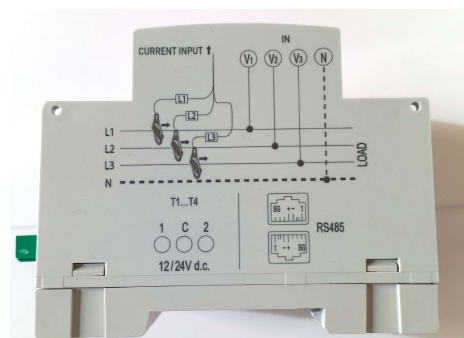
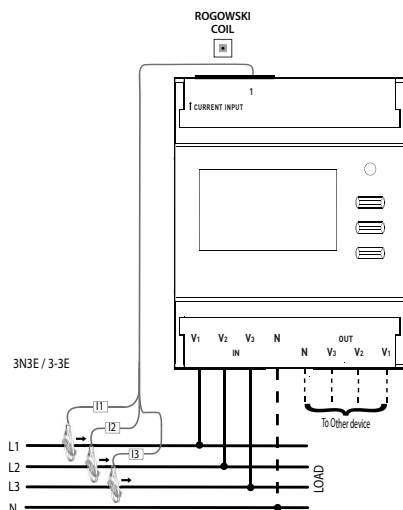
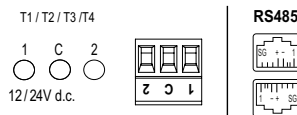

• **Installazione • Installation • Installation • Installieren • Instalación**

- **Schema di collegamento RS485 • RS485 wiring diagram • Schéma de branchement RS485**
- **Anschlussbilder RS485 • Esquema de conexión RS485**

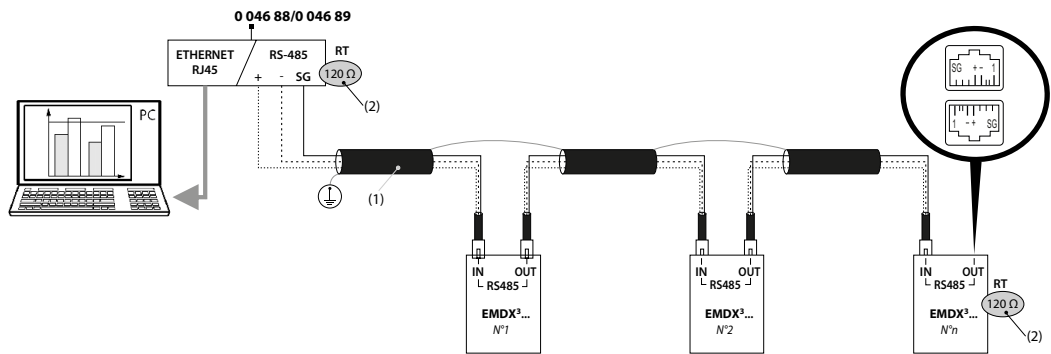

- (1) BELDEN 9842, BELDEN 3106A (or/equivalent) max. 1000 m, Cat. 6 (FTP/UTP) max. 50 m
- (2) Resistenza di terminazione da 120Ω interna allo strumento (impostabile dal menù di SETUP)
 - 120Ω terminating resistor inside the instrument (it can be set in the SETUP menu)
 - Résistance de terminaison de 120 Ω intégrée à l'instrument (réglable dans le menu de RÉGLAGE)
 - 120Ω Abschlusswiderstand intern im Gerät (einstellbar über das SETUP-Menü)
 - Resistencia de terminación de 120Ω interna en el instrumento (ajustable en el menú SETUP)
- (3) Ethernet: Cat. 6 (FTP/UTP)

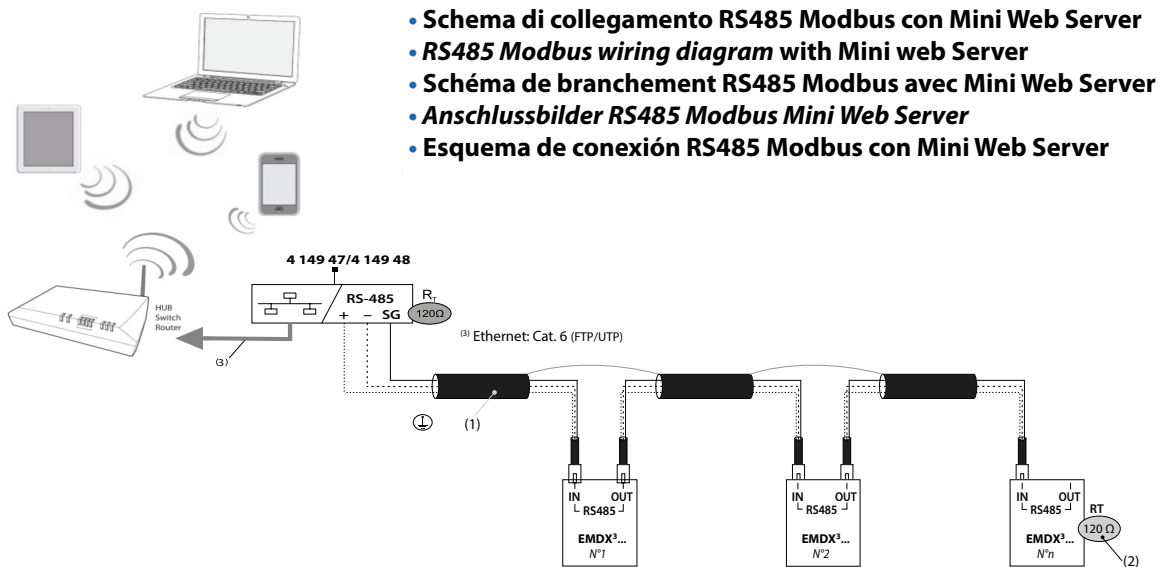

- **Schema di collegamento RS485 Modbus con Mini Web Server**
- **RS485 Modbus wiring diagram with Mini web Server**
- **Schéma de branchement RS485 Modbus avec Mini Web Server**
- **Anschlussbilder RS485 Modbus Mini Web Server**
- **Esquema de conexión RS485 Modbus con Mini Web Server**

• Utilizzo • Use • Utilisation • Verwendung • Utilización

• Navigazione pagine di visualizzazione

Il dispositivo è dotato di un display grafico su cui è riportata la funzione eseguita dal tasto corrispondente ed è dipendente dalla pagina visualizzata.

• Navigation display pages

The device is equipped with a graphic display showing the function performed by the corresponding key and is dependent on the page displayed.

• Pages d'affichage de navigation

L'appareil est équipé d'un écran graphique indiquant la fonction remplie par la touche correspondante et est dépendant de la page affichée

• Durchsuchen von Anzeigeseiten

Das Gerät ist mit einem Grafikdisplay ausgestattet, das die von der entsprechenden Taste ausgeführte Funktion anzeigt und ist abhängig von der angezeigten Seite

• Navegando por páginas de visualización

El dispositivo está equipado con una pantalla gráfica que muestra la función realizada por la tecla correspondiente y está depende de la página mostrada

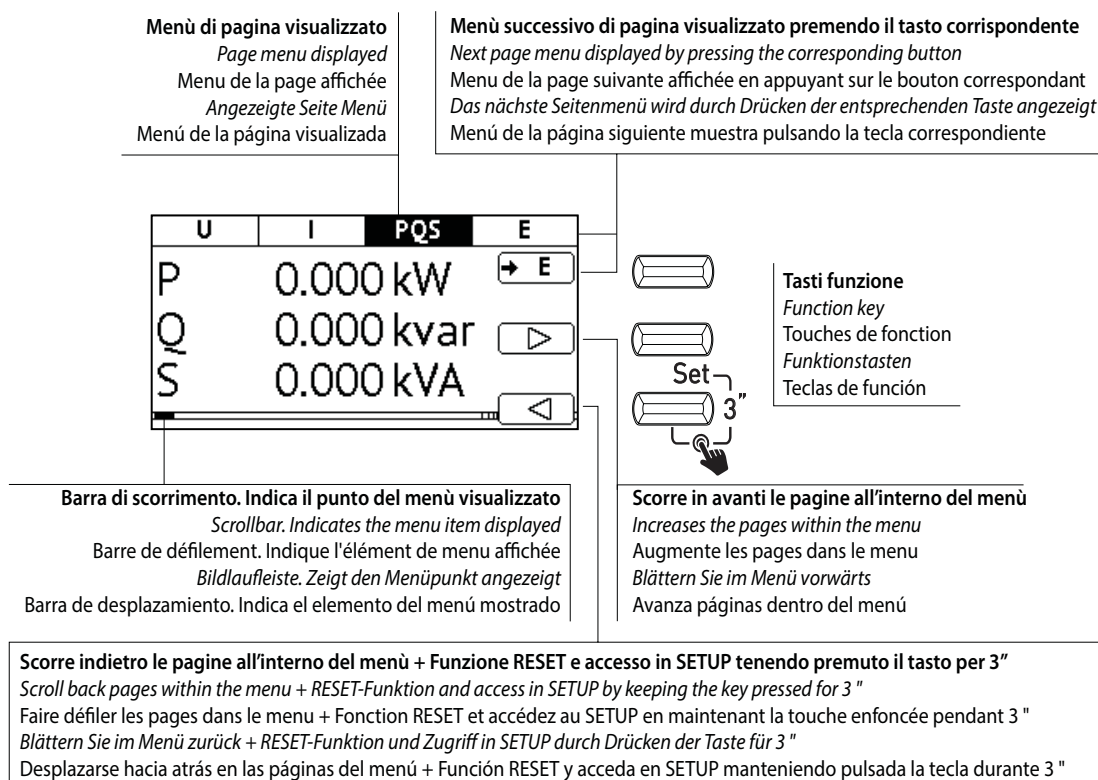

• Utilizzo • Use • Utilisation • Verwendung • Utilización

• Tensioni • Voltages • Tensions • Spannungen • Tensiones

U	I	PQS	E
U ₁	230.1 V		↔ I
U ₂	230.0 V		▶
U ₃	230.0 V		◀
U	I	PQS	E
U ₁₂	0.0 V		↔ I
U ₂₃	0.0 V		▶
U ₃₁	0.0 V		◀
U	I	PQS	E
U _{min1}	0.0 V		↔ I
U _{min2}	0.0 V		▶
U _{min3}	0.0 V		3" Rst ◀
U	I	PQS	E
U _{max1}	0.0 V		↔ I
U _{max2}	0.0 V		▶
U _{max3}	0.0 V		3" Rst ◀
U	I	PQS	E
U _{1thd}	0.0 %		↔ I
U _{2thd}	0.0 %		▶
U _{3thd}	0.0 %		◀
U	I	PQS	E
THDU1	60.0 %		↔ I
			3" ◀
U	I	PQS	E
THDU2	60.0 %		↔ I
			3" ◀
U	I	PQS	E
THDU3	60.0 %		↔ I
			3" ◀
U	I	PQS	E
$\Phi_{(U1-U2)}$	119.8 °		↔ I
$\Phi_{(U2-U3)}$	120.0 °		▶
$\Phi_{(U3-U1)}$	120.2 °		◀
U	I	PQS	E
f	50.00 Hz		▶
U	I	PQS	E
Total Run Hours	h.m		↔ I
TOT	000000.00		▶
			3" Rst ◀
U	I	PQS	E
Tarif Hours	h.m		↔ I
T ₁	000000.00		▶
T ₂	000000.00		◀
U	I	PQS	E
Tarif Hours	h.m		↔ I
T ₃	000000.00		▶
T ₄	000000.00		◀

Modbus

Tensioni di fase

Phase voltages
Tension simple
Phasenspannungen
Tensiones de fase

Tensioni concatenate

Linked voltages
Tensions composée
Verketteten Spannungen
Tensiones concatenadas

Minimi di tensione

Minimum voltage
Tension minimum
Minimale Spannung
Tensión mínimo

Massimi di tensione

Maximum voltage
Tension maximum
Maximale Spannung
Tensión máximo

THD di tensione fase

Phase voltage THD
Tension de phase THD
Phasenspannung THD
THD de tensión de fase

Spettro armoniche dispari tensione di fase 1 (*)

Phase 1 voltage odd harmonics spectrum
Spectre d'harmoniques impaires de tension de phase 1
Phase 1 Spannung ungerade Harmonische Spektrum
Espectro de armónicos impares de tensión de fase 1

Spettro armoniche dispari tensione di fase 2 (*)

Phase 2 voltage odd harmonics spectrum
Spectre d'harmoniques impaires de tension de phase 2
Phase 2 Spannung ungerade Harmonische Spektrum
Espectro de armónicos impares de tensión de fase 2

Spettro armoniche dispari tensione di fase 3 (*)

Phase 3 voltage odd harmonics spectrum
Spectre d'harmoniques impaires de tension de phase 3
Phase 3 Spannung ungerade Harmonische Spektrum
Espectro de armónicos impares de tensión de fase 3

Sfasamento fra le tensioni di fase

Phase shift between the phase voltages
Décalage de phase entre les tensions de phase
Phasenverschiebung zwischen den Phasenspannungen
Desplazamiento de fase entre las tensiones de fase

Frequenza di rete

Network frequency
Fréquence du réseau
Netzwerkfrequenz
Frecuencia de red

Conteggio orario

Hour counter
Compteur d'heures
Zeitähler
Contador de horas

Conteggio orario T1 / T2

Hour counter T1/T2
Compteur d'heures T1/T2
Zeitähler T1/T2
Contador de horas T1/T2

Conteggio orario T3 / T4

Hour counter T3/T4
Compteur d'heures T3/T4
Zeitähler T3/T4
Contador de horas T3/T4

• Utilizzo • Use • Utilisation • Verwendung • Utilización

• Correnti • Currents • Courants • Ströme • Corrientes

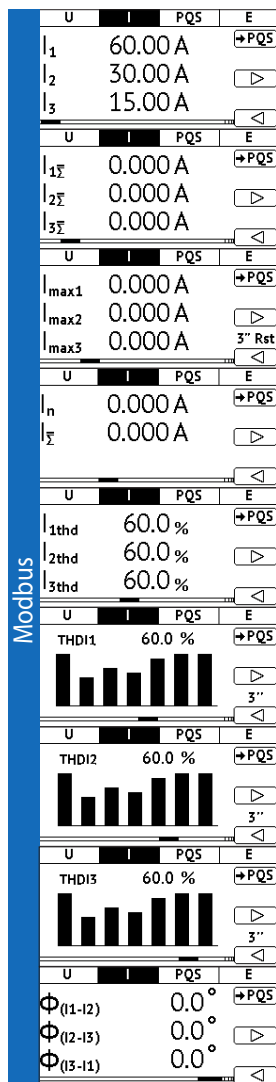

Correnti di fase

Phase currents
Courant par phase
Phasenströme
Corrientes de fase

Correnti di medie

Average currents
Courants moyens
Mittelströme
Corrientes medias

Picchi di corrente

Current peaks
Pics de courant
Stromspitzen
Picos corriente

Corrente di neutro e media delle 3 correnti di fase

Neutral and average current of the 3 phase currents
Courant de neutre et de la moyenne des 3 courants de phase
Neutral- und Durchschnittsstrom der 3 Phasenströme
Corriente neutra y media de las corrientes de fase 3

THD di corrente per fase

Phase current THD
Courant de phase THD
Phasenstrom THD
THD de corriente de fase

Spettro armoniche dispari corrente di fase 1 (*1)

Phase 1 current odd harmonics spectrum
Spectre d'harmoniques impaires de courant de phase 1
Phase 1 Strom ungerade Harmonische Spektrum
Espectro de armónicos impares de corriente de fase 1

Spettro armoniche dispari corrente di fase 2 (*1)

Phase 2 current odd harmonics spectrum
Spectre d'harmoniques impaires de courant de phase 2
Phase 2 Strom ungerade Harmonische Spektrum
Espectro de armónicos impares de corriente de fase 2

Spettro armoniche dispari corrente di fase 3 (*1)

Phase 3 current odd harmonics spectrum
Spectre d'harmoniques impaires de courant de phase 3
Phase 3 Strom ungerade Harmonische Spektrum
Espectro de armónicos impares de corriente de fase 3

Angoli tra le fasi di corrente

Angles between the phases of current
Angles entre les phases de courant
Winkel zwischen den Stromphasen
Ángulos entre las fases de corriente

Nota (*1):

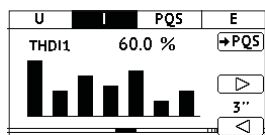

Navigation aggiuntiva per la visualizzare le singole armoniche
Additional navigation to view the individual harmonics
Navigation supplémentaire pour afficher les harmoniques individuelles
Zusätzliche Navigation zur Anzeige der einzelnen Harmonischen
Navegación adicional para ver los armónicos individuales

Scorrere avanti o indietro per visualizzare il valore delle singole armoniche
Scroll forward or backward to view the value of the individual harmonics
Faites défiler vers l'avant ou vers l'arrière pour afficher la valeur des harmoniques individuelles
Scrollen Sie vorwärts oder rückwärts, um den Wert der einzelnen Harmonischen anzuzeigen
Desplácese hacia adelante o hacia atrás para ver el valor de los armónicos individuales

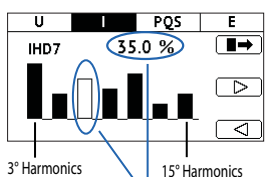

3^o Harmonics 15^o Harmonics

Armonica selezionata e valore percentuale
Harmonic selected and percentage value
Harmonique sélectionnée et valeur en pourcentage
Harmonische ausgewählt und Prozentwert
Armónico seleccionado y valor porcentual

Premere per uscire dalla modalità di visualizzazione, dopo 1min. di inattività esce automaticamente
Press to exit display mode, automatically exits after 1min. of inactivity
Appuyez pour quitter le mode d'affichage, quitte automatiquement après 1 min d'inactivité
Drücken Sie, um den Anzeigemodus zu verlassen. Wird nach 1 Minute Inaktivität automatisch beendet
Presione para salir del modo de visualización, sale automáticamente después de 1 min. de inactividad

• Utilizzo • Use • Utilisation • Verwendung • Utilización

• Potenze • Powers • Puissance • Leistung • Potestades

	U	I	PQS	E
Modbus	P	60.00 kW	→ E	E
	Q	50.01 kvar	▷	
	S	78.00 kVA	◁	
	P ₁	0.000 kW	→ E	E
	P ₂	0.000 kW	▷	
	P ₃	0.000 kW	◁	
	Q ₁	0.000 kvar	→ E	E
	Q ₂	0.000 kvar	▷	
	Q ₃	0.000 kvar	◁	
	S ₁	0.000 kVA	→ E	E
	S ₂	0.000 kVA	▷	
	S ₃	0.000 kVA	◁	
	Distortion Power	0.000 kVA	▷	
	Φ _(U1-I1)	0.0°	→ E	E
	Φ _(U2-I2)	0.0°	▷	
Φ _(U3-I3)	0.0°	◁		
PF	0.000	→ E	E	
PF _{min}	0.000	▷		
PF _{min}	0.000	3" Rst		
PF ₁	0.707	→ E	E	
PF ₂	0.707	▷		
PF ₃	0.707	◁		
P _{MD}	0.000 kW	→ E	E	
Q _{MD}	0.000 kvar	▷		
S _{MD}	0.000 kVA	◁		
P _{PMD}	0.000 kW	→ E	E	
Q _{PMD}	0.000 kvar	▷		
S _{PMD}	0.000 kVA	3" Rst		

Potenze trifase

Three-phase powers
Puissance triphasés
Dreiphasige Leistungen
Potencias trifásicas

Potenze attive di fase

Phase active powers
Puissance active par phase)
Wirkleistungen je Phase
Fases de potencias activas

Potenze reattive di fase

Phase reactive powers
Puissance reactive par phase
Blindleistungen je Phase
Fases de potencias reactivas

Potenze apparenti di fase

Phase apparent powers
Puissance apparente par phase
Scheinleistungen je Phase
Fases de potencias aparentes

Potenza distortente

Distortion power
Puissance déformante
Verzerren Leistungen
Potencia distorsionando

Sfasamento fra le potenze di fase

Phase shift between the phase voltages
Décalage de phase entre les puissances de phase
Phasenverschiebung zwischen den Phasenleistung
Desplazamiento de fase entre de potencias de fase

Fattore di potenza trifase; Fattore di potenza max. e min.

Three-phase power factor; Power factor max. and min.
Facteur de puissance triphasé; Facteur de puissance max. et min.
Dreiphasiger Leistungsfaktor; Leistungsfaktor max. und min.
Factor de potencia trifásico; Factor de potencia max. y min.

Fattore di potenza di fase

Phase power factor
Facteur de puissance par phase
Leistungsfaktor je Phase
Fases de factor de potencia

Potenze medie trifase

Three-phase powers demand
Puissance moyenne triphasés
Dreiphasige Durchschnittsleistungen
Potencias media trifásicas

Picco max. della potenza trifase

Max peak of the three-phase power
Pic max de la puissance triphasée
Peax Peak der dreiphasigen Leistung
Pico máximo de la potencia trifásica

• Utilizzo • Use • Utilisation • Verwendung • Utilización

• Potenze • Powers • Puissance • Leistung • Potestades

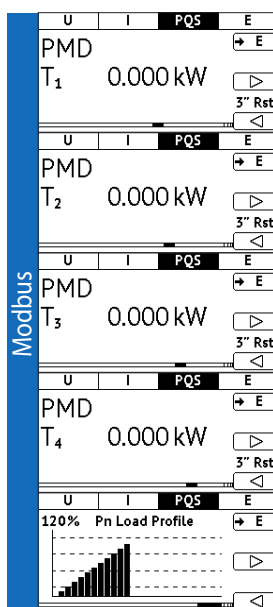

Picco max. della potenza T1

Max peak of the power T1
Pic max de la puissance T1
Max. Leistungsspitze T1
Pico máximo de la potencia T1

Picco max. della potenza T2

Max peak of the power T2
Pic max de la puissance T2
Max. Leistungsspitze T2
Pico máximo de la potencia T2

Picco max. della potenza T3

Max peak of the power T3
Pic max de la puissance T3
Max. Leistungsspitze T3
Pico máximo de la potencia T3

Picco max. della potenza T4

Max peak of the power T4
Pic max de la puissance T4
Max. Leistungsspitze T4
Pico máximo de la potencia T4

Curva di carico (*2)

Load curve
Courbe de charge
Kurve laden
Curva de carga

Nota (*2):

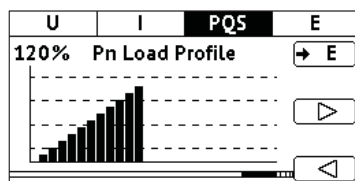

Curva di carico 24 righe massime, ogni riga rappresenta un'unità di tempo pari al valore impostato in configurazione

Load curve 24 lines maximum, each line represents a unit of time equal to the value set in configuration

Courbe de charge 24 lignes maximum, chaque ligne représente une unité de temps égale à la valeur définie en configuration

Kurve laden 24 Zeilen maximal repräsentiert jede Zeile eine Zeiteinheit gleich dem eingestellten Wert in der Konfiguration

Curva de carga 24 líneas máximo, a línea representa una unidad de tiempo igual al valor establecido en la configuración

• **Utilizzo • Use • Utilisation • Verwendung • Utilización**

• **Energie • Energies • Energies • Energien • Energías**

Modbus

U	I	PQ5	E
Ea (TOT)		kWh	→ U
Ea+	0000000.00		▶
Ea-	0000000.00		◀
U	I	PQ5	E
Ea+ (L1)		kWh	→ U
	0000000.00		▶
U	I	PQ5	E
Ea+ (L2)		kWh	→ U
	0000000.00		▶
U	I	PQ5	E
Ea+ (L3)		kWh	→ U
	0000000.00		▶
U	I	PQ5	E
Er (TOT)		kvarh	→ U
Er+	0000000.00		▶
Er-	0000000.00		◀
U	I	PQ5	E
Er+ (L1)		kvarh	→ U
	0000000.00		▶
U	I	PQ5	E
Er+ (L2)		kvarh	→ U
	0000000.00		▶
U	I	PQ5	E
Er+ (L3)		kvarh	→ U
	0000000.00		▶
U	I	PQ5	E
Ea+		kWh	→ U
T ₁	0000000.00		▶
T ₂	0000000.00		◀
U	I	PQ5	E
Ea+		kWh	→ U
T ₃	0000000.00		▶
T ₄	0000000.00		◀
U	I	PQ5	E
Er+		kvarh	→ U
T ₁	0000000.00		▶
T ₂	0000000.00		◀
U	I	PQ5	E
Er+		kvarh	→ U
T ₃	0000000.00		▶
T ₄	0000000.00		◀
U	I	PQ5	E
Ea+ (Par)		kWh	→ U
	0000000.00		▶
		3" Rst	◀

Energia attiva totale positiva e negativa

Total positive and negative active energy
Energie active positive et négative totale
Total positive und negative Wirkenergie
Energía activa positiva y negativa total

Energia attiva di fase 1

Phase active energy 1
Energie active par phase 1
Wirkenergie je Phase 1
Fases de energía activa 1

Energia attiva di fase 2

Phase active energy 2
Energie active par phase 2
Wirkenergie je Phase 2
Fases de energía activa 2

Energia attiva di fase 3

Phase active energy 3
Energie active par phase 3
Wirkenergie je Phase 3
Fases de energía activa 3

Energia reattiva totale positiva e negativa

Total positive and negative reactive energy
Énergie réactive totale positive et négative
Total positive und negative Blindenergie
Energía reactiva positiva y negativa total

Energia reattiva di fase 1

Phase reactive energy 1
Energie reactive par phase 1
Blindenergie je Phase 1
Fases de energía reactiva 1

Energia reattiva di fase 2

Phase reactive energy 2
Energie reactive par phase 2
Blindenergie je Phase 2
Fases de energía reactiva 2

Energia reattiva di fase 3

Phase reactive energy 3
Energie reactive par phase 3
Blindenergie je Phase 3
Fases de energía reactiva 3

Energia attiva positiva T1 e T2

Positive active energy T1/T2
Energie active positive T1/T2
Positive Wirkenergie T1/T2
Energía activa positiva T1/T2

Energia attiva positiva T3 e T4

Positive active energy T3/T4
Energie active positive T3/T4
Positive Wirkenergie T3/T4
Energía activa positiva T3/T4

Energia reattiva positiva T1 e T2

Positive reactive energy T1/T2
Energie réactive positive T1/T2
Positive Blindenergie T1/T2
Energía reactiva positiva T1/T2

Energia reattiva positiva T3 e T4

Positive reactive energy T3/T4
Energie réactive positive T3/T4
Positive Blindenergie T3/T4
Energía reactiva positiva T3/T4

Energia attiva positiva parziale

Partial positive active energy
Energie active positive partielle
Positive teilweise Wirkenergie
Energía activa parcial positiva

• Utilizzo • Use • Utilisation • Verwendung • Utilización

• Energie • Energies • Energies • Energien • Energías

Modbus	U I PQS E	Ea- (Par)	kWh	→ U
	0000000.00	▶	3" Rst	◀
	Energia attiva negativa parziale			
	<i>Negative partial active energy Energie active partielle negative Negative teilweise Wirkenergie Energia activa parcial negativa</i>			
U I PQS E	Er+ (Par)	kvarh	→ U	
0000000.00	▶	3" Rst	◀	
Energia reattiva positiva parziale				
<i>Partial positive reactive energy Energie réactive positive partielle Positive teilweise Blindenergie Energia reactiva parcial positiva</i>				
U I PQS E	Er- (Par)	kvarh	→ U	
0000000.00	▶	3" Rst	◀	
Energia reattiva negativa parziale				
<i>Negative partial reactive energy Energie réactive partielle negative Negative teilweise Blindenergie Energia reactiva parcial negativa</i>				
U I PQS E	Eapp	kVAh	→ U	
0000000.00	▶	3" Rst	◀	
Energia apparente totale				
<i>Total apparent energy Energie apparente totale Scheinbare Gesamtenergie Energia aparente total</i>				

• Azzeramento • Reset • Remise à zéro • Rücksetzen • Volver a cero

U I PQS E
Total Run Hours h.m → I
TOT 019999.53 ▶
3" Rst ◀

x1
3" sec.
Reset

U I PQS E
Total Run Hours h.m → I
TOT 000000.00 ▶
3" Rst ◀

Nota: L'azzeramento è possibile solo nelle pagine dove appare la dicitura **3" Rst**
Reset is possible only in the pages where 3" Rst appears
 Mise à zéro est possible que sur les pages où apparait le libellé **3" Rst**
Ein Zurücksetzen ist nur auf den Seiten möglich, auf denen 3" Rst zuerst angezeigt wird
 Reducción a cero es posible sólo en las páginas en las que aparece el texto **Rst 3"**

• Programmazione • Programming • Programmation • Programmierung • Programación

- Tenendo premuto il tasto **Set** per **3"** si accede alla visualizzazione dei parametri di setup.
- *Keeping the key **Set** pressed for **3"** accesses the setup parameters display.*
- En maintenant enfoncé le bouton **Set** pendant **3"** pour accéder à l'affichage des paramètres de configuration.
- *Durch Drücken der Taste **Set** für **3"** wird die Anzeige der Setup-Parameter aufgerufen.*
- Si mantiene pulsado el botón **Set** durante **3"** lleva a la pantalla de parámetros de configuración.

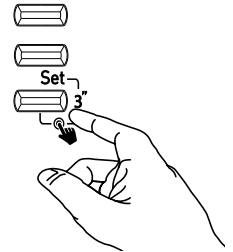

Modbus 4 121 48

SETUP	Address	005	Indirizzo RS485 RS485 address Adresse RS485 Adresse RS485 Dirección RS485
SETUP	Baudrate	19.2 kbit/s	Velocità di comunicazione Communication speed Vitesse de communication Kommunikationsgeschwindigkeit Velocidad de comunicación
SETUP	Parity	Even	Bit di parità Parity bit Bit de parité Paritätsbit Bit de paridad
SETUP	Termination	None	Resistenza di terminazione Termination resistance Résistance de terminaison Kündigungswiderstand Resistencia de terminación
SETUP	Int. time (MD)	5 Minutes	Tempo di integrazione (T5x24 righe =120min.) Tempo di integrazione (T5x24 righe =120min.) Temps d'intégration moyen (T5x24 righe =120min.) Integrationszeit (T5x24 righe =120min.) Tiempo de integración (T5x24 righe =120min.)
SETUP	Run hours thr	00.00 MW	Soglia in potenza del conteggio orario Threshold in power of the hourly count Seuil en puissance du décompte horaire Leistungsschwelle der Stundenzählung Umbral de potencia del recuento horario
SETUP	Wiring	3n-3E	Tipo di connessione Connection type Type de connexion Verbindungstyp Tipo de conexión
SETUP	Current Range	630 A	Portata di corrente Current range Capacité courant Strombelastbarkeit Capacidad de corrientes
SETUP	Change psw	0000	Modifica Password Change Password Changer le mot de passe Kennwort ändern Cambiar contraseña
SETUP	L.G412048 Version : V1.101		Versione Software Software version Version du software Softwareversion Versión de software

• Programmazione • Programming • Programmation • Programmierung • Programación

- Modifica dati di SETUP • Changing SETUP data • Modification des données SETUP
- Ändern der Setup-Daten • Modificación de los datos de configuración

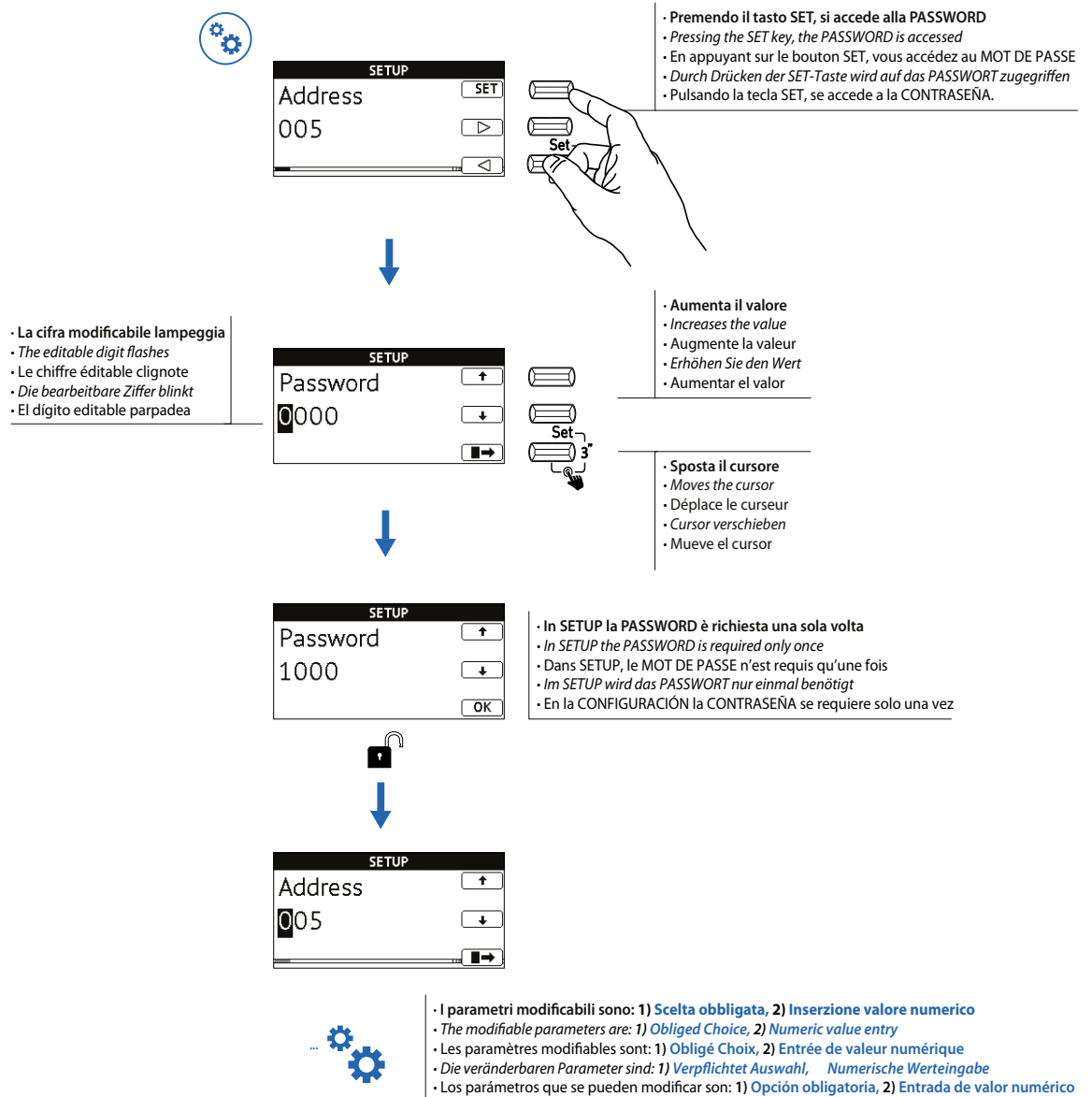

• Programmazione • Programming • Programmation • Programmierung
• Programación

• I parametri modificabili sono: • The modifiable parameters are: • Les paramètres modifiables sont:
• Die veränderbaren Parameter sind: • Los parámetros que se pueden modificar son:



1

- Scelta obbligata
- Obligated Choice
- Obligé Choix
- Verpflichtet Auswahl
- Opción obligatoria

- La cifra modificabile lampeggia
- The editable digit flashes
- Le chiffre éditabile clignote
- Die bearbeitbare Ziffer blinkt
- El dígito editable parpadea

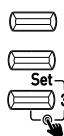
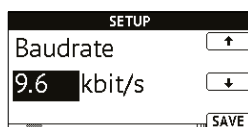

- Cambia la scelta
- Change the choice
- Changer le choix
- Ändern Sie die Auswahl
- Cambiar la elección

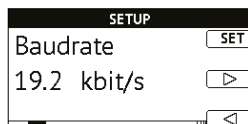

- Salva la modifica e sposta al setup successivo
- Save the change and move to the next setup
- Enregistrez la modification et passez à la configuration suivante
- Speichern Sie die Änderung und fahren Sie mit dem nächsten Setup fort
- Guarde el cambio y pase a la siguiente configuración

2

- Inserzione valore numerico
- Numeric value entry
- Entrée de valeur numérique
- Numerische Werteingabe
- Entrada de valor numérico

- La cifra modificabile lampeggia
- The editable digit flashes
- Le chiffre éditabile clignote
- Die bearbeitbare Ziffer blinkt
- El dígito editable parpadea

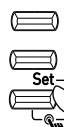
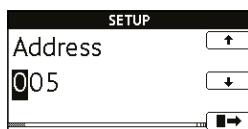

x 2

- Sposta alla cifra modificata successiva
- Move to the next digit modified
- Déplacer vers le chiffre suivant modifié
- Bewegen Sie zur nächsten Stelle geändert
- Mover a la siguiente figura modificada

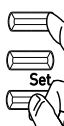

x 1

- Aumenta il valore
- Increases the value
- Augmente la valeur
- Erhöhen Sie den Wert
- Aumentar el valor

- Salvare
- Save
- Sauver
- Speichern
- Salvar

• Comunicazione

Il dispositivo comunica utilizzando il protocollo MODBUS® che implica un dialogo secondo una logica master/slave. Tipologia di indirizzamento:

- punto-punto (il master comunica con un solo dispositivo slave alla volta).

La comunicazione avviene con modalità RTU (Remote Terminal Unit).

Sintassi di comunicazione

Per la sintassi standard di comunicazione fare riferimento alla Tabella di comunicazione Modbus

Conformemente al protocollo MODBUS®, affinché un il messaggio sia considerato valido dai dispositivi, il tempo massimo di attesa tra due parti del messaggio stesso deve essere inferiore a 3,5 volte il cosiddetto "tempo di intercarattere" (carattere = 8 bit di dati).

Tablelle di comunicazione

Le tabelle di comunicazione MODBUS sono disponibili sul sito <https://www.legrand.com/ecatalogue/>

• Communication

The device communicates using the MODBUS® protocol which implies a dialogue using a master-slave logic. structure. Addressing type:

- *point-point (the master communicates one slave at once).*

The communication takes place with RTU (Remote Terminal Unit) mode.

Communication syntax

For the standard communication syntax, refer to the Modbus communication table

According to the MODBUS® protocol, for the devices to consider the message to be valid, the maximum waiting time between two parts of the message itself must be less than 3.5 times the "intercharacter time" (character = 8 bit data).

Communication table

The MODBUS communication tables are available on the website <https://www.legrand.com/ecatalogue/>

• Communication

Le produit communique à partir d'un protocole MODBUS® qui implique un dialogue selon une structure maître/esclave. Type d'adressage:

- point à point (le maître ne communique qu'avec un seul appareil esclave à la fois).

Le mode de communication est le mode RTU (Remote Terminal Unit) a

Trame de communication standard

Elle est composée de : Conformément au protocole MODBUS®, le temps intercaractère doit être \leq à 3 silences. C'est-à-dire au temps d'émission de 3 caractères pour que le message soit traité par le produits (1 caractère = 8 bits). **Table de communication**

Les tables de communication sont disponibles sur le site Web <https://www.legrand.com/ecatalogue/>

• Kommunikation

Die Geräte kommunizieren über das MODBUS® -Protokoll, was einen Dialog nach einer Master/Slave-Logik impliziert. Adressierungsart:

- *Punkt-zu-Punkt (der Master kommuniziert mit jeweils nur einem Slave-Gerät).*

Die Kommunikation erfolgt im RTU-Modus (Remote Terminal Unit).

Kommunikationssyntax

Die Standard-Kommunikationssyntax entnehmen Sie bitte der Modbus-Kommunikationstabelle.

Nach dem MODBUS® -Protokoll muss die maximale Wartezeit zwischen zwei Teilen der Nachricht selbst weniger als das 3,5-fache der sogenannten "Zwischenzeit" (Zeichen = 8 Bit Daten) betragen, damit eine Nachricht von die Geräte als gültig betrachtet werden kann.

Kommunikationstabelle

Die MODBUS-Kommunikationstabellen stehen unter <https://www.legrand.com/ecatalogue/> zur Verfügung.

• Comunicación

El dispositivo comunica utilizando el protocolo MODBUS®, que contempla un diálogo según una lógica master/slave.

Tipología de enrutamiento:

- punto-punto (el master comunica con un solo dispositivo slave a la vez).

La comunicación se produce en la modalidad RTU (Remote Terminal Unit).

Sintaxis de comunicación

Para la sintaxis estándar de comunicación, consultar la Tabla de comunicación Modbus

En conformidad al protocolo MODBUS®, para que el mensaje sea considerado válido por los dispositivos el tiempo máximo de espera entre dos partes del mensaje ha de ser 3,5 veces menor que el denominado "tiempo de intercarácter" (carácter = 8 bit de datos).

Tablas de comunicación

Las tablas de comunicación MODBUS están disponibles en el sitio web <https://www.legrand.com/ecatalogue/>

• Sequenza di collegamento • Connection sequence • Séquence de connexion • Verbindungssequenz • Secuencia de conexión

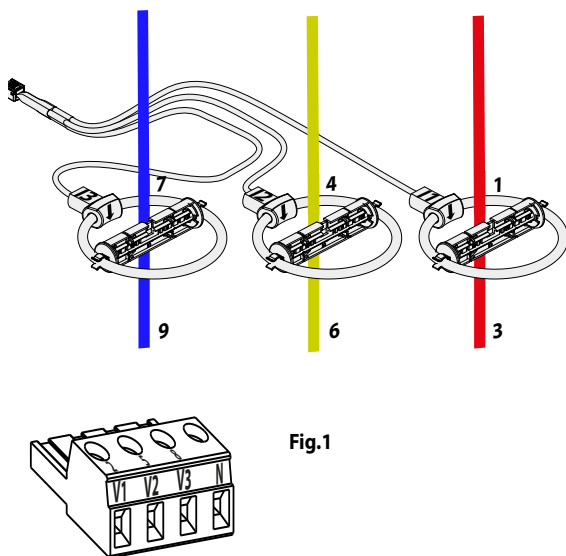

Fig.1

La sequenza corretta delle Fasi di Tensione è: **2 5 8**
 (V1 al morsetto 2); (V2 al morsetto 5); (V3 al morsetto 8)
 La sequenza corretta delle Fasi di Corrente è: **1.3 4.6 7.9**
 come indicato in Fig.1

The correct sequence of the Voltage Phases is: **2 5 8**
 (V1 at terminal 2); (V2 at terminal 5); (V3 at terminal 8)
 The correct sequence of the Current Phases is: **1.3 4.6 7.9**,
 as shown in Fig.1

La séquence correcte des Phases de Tension est: **2 5 8**
 (V1 à la borne 2); (V2 au terminal 5); (V3 au terminal 8)
 es Phases Actuelles est: **1.3 4.6 7.9**,
 comme indiqué sur la Fig.1

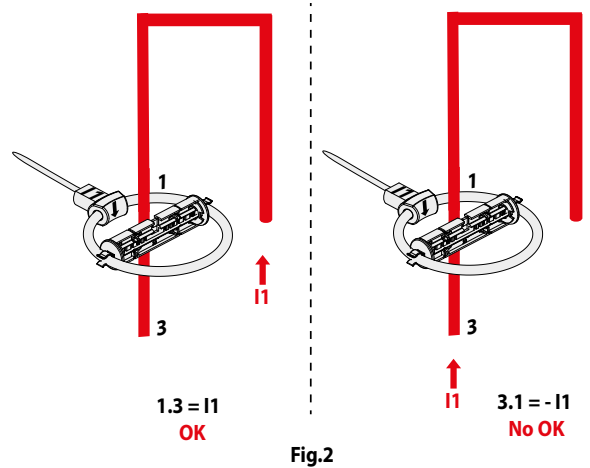







Fig.2

Die korrekte Reihenfolge der Spannungsphasen lautet: **2 5 8**
 (V1 an Klemme 2); (V2 an Klemme 5); (V3 an Klemme 8)
 Die korrekte Reihenfolge der aktuellen Phasen lautet:
1.3 4.6 7.9, wie in Fig.1

La secuencia correcta de las Fases de Voltaje es: **2 5 8**
 (V1 en la terminal 2); (V2 en la terminal 5); (V3 en la terminal 8)
 La secuencia correcta de las Fases Corriente es: **1.3 4.6 7.9**,
 como se muestra en la Fig.1

• Caratteristiche tecniche











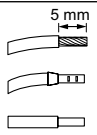

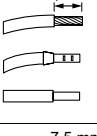

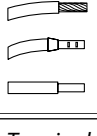

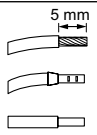

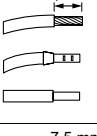
Involucro			
Dimensioni (l x h x p)	71,2 x 92,4 x 66mm		
Collegamenti	 1 C 2  V1-V2-V3-N 2 5 8 11  N-V3-V2-V1	5 mm MAX 1 x 1mm ² 1 x 1mm ² 1 x 1mm ² 7,5 mm MAX 1 x 1,5mm ² 1 x 2,5mm ² 1 x 1,5mm ² 7,5 mm MAX 1 x 1,5mm ² 1 x 2,5mm ² 1 x 1,5mm ²	Recommended torque 0,2Nm 0,5 x 3mm  Recommended torque 0,5Nm 0,5 x 3,5mm COMBI PH1  Recommended torque 0,5Nm 0,5 x 3,5mm 
	Grado di protezione:	Frontale IP54, Morsetti IP20	
	Peso:	270 gr.	
Display			
Tipo:	Grafico retroilluminato 1.8 pollici (256x128)		
Alimentazione ausiliaria:			
Derivata delle prese di tensione (Autoalimentato)			
Misura			
Rete trifase 3 e 4 fili			
Tensione (TRMS)			
Misura diretta			
Tensione trifase nominale Un:	3x230V~ / 3x400V~ ± 15%		
Autoconsumo circuito di tensione:	Max. 1,8VA trifase		
Classe di precisione delle tensioni:	0,5		
Correnti (TRMS) Misura diretta	4 121 08 $I_{min} 12,5A - I_{ref} 250A - I_{max} 750A$		
	4 121 09 $I_{min} 32,5A - I_{ref} 650A - I_{max} 1900A$		
	4 121 10 $I_{min} 65A - I_{ref} 1300A - I_{max} 3900A$		
	4 121 11 $I_{min} 125A - I_{ref} 2500A - I_{max} 7500A$		
Classe di precisione delle correnti:	1		
Frequenza			
Frequenza nominale	F _n 50Hz; 60Hz		
Variazione ammessa	45...65Hz		
Energie			
Classe di precisione Energia Attiva:	1 (EN 62053-21)		
Classe di precisione Energia Reattiva:	2 (EN 62053-23)		

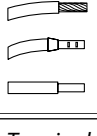
• Caratteristiche tecniche

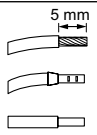
Ingressi digitali	
Tensione:	12-24V DC
Corrente:	Max. 10 mA
Condizioni di utilizzo	
Temperatura di funzionamento:	(-20°C) ÷ (60°C)
Temperatura di immagazzinamento:	(-25°C) ÷ (70°C)
Umidità:	Adatto all'utilizzo in clima tropicale
Massima potenza dissipata:	< 5 W
Ambiente meccanico:	M1
Ambiente elettromagnetico:	E2
Umidità relativa:	95% senza condensa (EN50472-1)
Installazione:	Montaggio del contatore all'interno di un quadro IP51
Utilizzo:	Uso interno

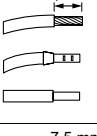
Marcatura CE	
Il dispositivo è conforme: <ul style="list-style-type: none"> • Alle disposizioni della Direttiva Europea sulla compatibilità elettromagnetica (EMC) n° 2014/30/EU • Alla Direttiva bassa tensione n° 2014/35/UE. • Alla Direttiva 2011/65/EU modificata dalla direttiva 2015/863 (RoHS 2). 	
Compatibilità elettromagnetica	
Prove in accordo con IEC/EN 62052-11 - EN 50470-1	
Isolamento (IEC/EN 62052-11, IEC/EN 62053-21)	
Categoria di misura:	III
Grado d'inquinamento:	2
Tensione d'isolamento, Ui:	300V Fase-Terra
Tenuta all'impulso:	-Ingressi di misura / Ingressi digitali I/O: onda 1,2 / 50µs 0,5 J: 6kV tensione alternata 50Hz / 1 min.: 3kV -Tutti i circuiti / Massa tensione alternata 50Hz / 1 min.: 4kV
Superficie frontale:	Classe II

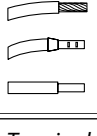
• Technical characteristics

Case										
Dimension (w x h x d)	71,2 x 92,4 x 66mm									
Connections	<table border="1" style="width: 100%; border-collapse: collapse;"> <tr> <td style="text-align: center; vertical-align: middle;">  1 C 2 </td> <td style="text-align: center; vertical-align: middle;">  5 mm MAX 1 x 1mm² 1 x 1mm² 1 x 1mm² </td> <td style="text-align: center; vertical-align: middle;"> Recommended torque 0,2Nm 0,5 x 3mm  </td> </tr> <tr> <td style="text-align: center; vertical-align: middle;">  V1-V2-V3-N 2 5 8 11 </td> <td style="text-align: center; vertical-align: middle;">  7,5 mm MAX 1 x 1,5mm² 1 x 2,5mm² 1 x 1,5mm² </td> <td style="text-align: center; vertical-align: middle;"> Recommended torque 0,5Nm 0,5 x 3,5mm COMBI PH1  </td> </tr> <tr> <td style="text-align: center; vertical-align: middle;">  N-V3-V2-V1 </td> <td style="text-align: center; vertical-align: middle;">  7,5 mm MAX 1 x 1,5mm² 1 x 2,5mm² 1 x 1,5mm² </td> <td style="text-align: center; vertical-align: middle;"> Recommended torque 0,5Nm 0,5 x 3,5mm  </td> </tr> </table>	 1 C 2	 5 mm MAX 1 x 1mm ² 1 x 1mm ² 1 x 1mm ²	Recommended torque 0,2Nm 0,5 x 3mm 	 V1-V2-V3-N 2 5 8 11	 7,5 mm MAX 1 x 1,5mm ² 1 x 2,5mm ² 1 x 1,5mm ²	Recommended torque 0,5Nm 0,5 x 3,5mm COMBI PH1 	 N-V3-V2-V1	 7,5 mm MAX 1 x 1,5mm ² 1 x 2,5mm ² 1 x 1,5mm ²	Recommended torque 0,5Nm 0,5 x 3,5mm 
 1 C 2	 5 mm MAX 1 x 1mm ² 1 x 1mm ² 1 x 1mm ²	Recommended torque 0,2Nm 0,5 x 3mm 								
 V1-V2-V3-N 2 5 8 11	 7,5 mm MAX 1 x 1,5mm ² 1 x 2,5mm ² 1 x 1,5mm ²	Recommended torque 0,5Nm 0,5 x 3,5mm COMBI PH1 								
 N-V3-V2-V1	 7,5 mm MAX 1 x 1,5mm ² 1 x 2,5mm ² 1 x 1,5mm ²	Recommended torque 0,5Nm 0,5 x 3,5mm 								
Degree of protection	Front face IP54, Terminals IP20									
Weight:	270 gr.									
Display										
Type:	Graphic backlit 1.8 inches (256x128)									
Auxiliary supply										
Derived from the voltage terminals (Self-supplied)										
Measurement										
Three-phase 3 and 4-wire network										
Voltage (TRMS) Direct measurement										
Three-phase rated voltage Un:	3x230V~ / 3x400V~ ± 15%									
Power consumption voltage circuit:	Max. 1,8VA three-phase									
Voltage accuracy class:	0,5									
Currents (TRMS) Direct measurement	4 121 08 $I_{min} 12,5A - I_{ref} 250A - I_{max} 750A$									
	4 121 09 $I_{min} 32,5A - I_{ref} 650A - I_{max} 1900A$									
	4 121 10 $I_{min} 65A - I_{ref} 1300A - I_{max} 3900A$									
	4 121 11 $I_{min} 125A - I_{ref} 2500A - I_{max} 7500A$									
Current accuracy class:	1									
Frequency										
Rated frequency	F_n 50Hz; 60Hz									
Permitted variation	45...65Hz									
Energies										
Active energy accuracy class:	1 (EN 62053-21)									
Reactive energy accuracy class:	2 (EN 62053-23)									

• **Technical characteristics**











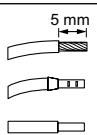

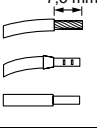

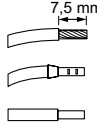

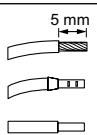

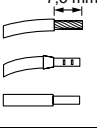
Digital inputs	
Voltage:	12-24V DC
Current:	Max. 10 mA
Operating conditions	
Operating temperature:	(-20°C) ÷ (60°C)
Storage temperature:	(-25°C) ÷ (70°C)
Humidity:	Suitable for tropical climates
Max. dissipated power:	< 5 W
Mechanical environment:	M1
Electromagnetic environment:	E2
Relative humidity:	95% not condensing (EN50472-1)
Installation:	Mounting the KWH-meter in a IP51 switchboard
Use:	Indoor

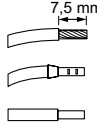
CE Marking	
<p>The device is comply with:</p> <ul style="list-style-type: none"> • The requirements of the European directive on electromagnetic compatibility (EMC) n° 2014/30/EU • The low voltage directive n° 2014/35/UE. • Directive 2011/65/EU modified by directive 2015/863 (RoHS 2). 	
Electromagnetic compatibility	
According to IEC/EN 62052-11 - EN 50470-1	
Insulation (IEC/EN 62052-11, IEC/EN 62053-21)	
Measurement category:	III
Degree of pollution:	2
Insulation voltage, Ui:	300V Phase-Earth
Impulse withstand voltage	<ul style="list-style-type: none"> - Measuring inputs / Digital I/O inputs wave 1,2 / 50µs 0,5 J: 6kV alternate voltage 50Hz / 1 min.: 3kV - All circuits / earth alternate voltage 50Hz / 1 min.: 4kV
Front surface:	Class II

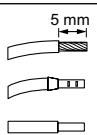
• Technical characteristics

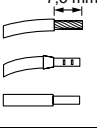
Conformity IEC 61557-12 Edition 1 (08/2007)			
PMD Characteristics			
Type of characteristic	Specification values	Other complementary characteristics	
Power quality assessment function	-	-	
Classification of PMD	SD	-	
Temperature	K55	-	
Humidity + Altitude	Standard conditions	-	
Characteristics of functions			
Function symbols	Function performance class according to IEC 61557-12	Measuring range (Accuracy)	Other complementary characteristics
P	1	* See Table Currents (TRMS) page 28	
Q_V	2		
S_A	1		
E_a	1 (IEC/EN 62053-21)		
E_{RV}	2 (IEC/EN 62053-23)		
I	1		
I_N, I_{Nc}	3		
E_{apAr}, E_{apV}	1 (IEC/EN 62053-21)	-	
f	± 0,5 Hz	45 ÷ 65 Hz	
U	0,5	195 ÷ 295 V (Ph/N)	
P_{FAr}, P_{FV}	0,5	0,5 ind ÷ 0,8 cap	
P_{str}, P_{It}	-	-	
U_{dip}	-	-	
U_{swl}	-	-	
U_{tr}	-	-	
U_{int}	-	-	
U_{nba}	-	-	
U_{nb}	-	-	
U_h	-	-	
THD_u	5	> 1,5 %	
THD - R_u	-	-	
I_h	-	-	
THD_i	5	> 3 %	
THD-R_i	-	-	
Msv	-	-	

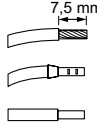
• Caractéristiques techniques











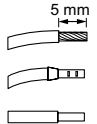

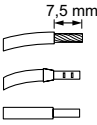

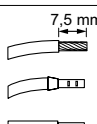

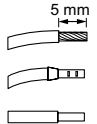

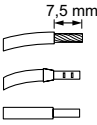
Boîtier										
Dimensions (l x h x p)	71,2 x 92,4 x 66mm									
Raccordement:	<table border="1" style="width: 100%; border-collapse: collapse;"> <tr> <td style="text-align: center; vertical-align: middle;">  1 C 2 </td> <td style="text-align: center; vertical-align: middle;">  5 mm MAX 1 x 1mm² 1 x 1mm² 1 x 1mm² </td> <td style="text-align: center; vertical-align: middle;"> Recommended torque 0,2Nm 0,5 x 3mm  </td> </tr> <tr> <td style="text-align: center; vertical-align: middle;">  V1-V2-V3-N 2 5 8 11 </td> <td style="text-align: center; vertical-align: middle;">  7,5 mm MAX 1 x 1,5mm² 1 x 2,5mm² 1 x 1,5mm² </td> <td style="text-align: center; vertical-align: middle;"> Recommended torque 0,5Nm 0,5 x 3,5mm COMBI PH1  </td> </tr> <tr> <td style="text-align: center; vertical-align: middle;">  N-V3-V2-V1 </td> <td style="text-align: center; vertical-align: middle;">  7,5 mm MAX 1 x 1,5mm² 1 x 2,5mm² 1 x 1,5mm² </td> <td style="text-align: center; vertical-align: middle;"> Recommended torque 0,5Nm 0,5 x 3,5mm  </td> </tr> </table>	 1 C 2	 5 mm MAX 1 x 1mm ² 1 x 1mm ² 1 x 1mm ²	Recommended torque 0,2Nm 0,5 x 3mm 	 V1-V2-V3-N 2 5 8 11	 7,5 mm MAX 1 x 1,5mm ² 1 x 2,5mm ² 1 x 1,5mm ²	Recommended torque 0,5Nm 0,5 x 3,5mm COMBI PH1 	 N-V3-V2-V1	 7,5 mm MAX 1 x 1,5mm ² 1 x 2,5mm ² 1 x 1,5mm ²	Recommended torque 0,5Nm 0,5 x 3,5mm 
 1 C 2	 5 mm MAX 1 x 1mm ² 1 x 1mm ² 1 x 1mm ²	Recommended torque 0,2Nm 0,5 x 3mm 								
 V1-V2-V3-N 2 5 8 11	 7,5 mm MAX 1 x 1,5mm ² 1 x 2,5mm ² 1 x 1,5mm ²	Recommended torque 0,5Nm 0,5 x 3,5mm COMBI PH1 								
 N-V3-V2-V1	 7,5 mm MAX 1 x 1,5mm ² 1 x 2,5mm ² 1 x 1,5mm ²	Recommended torque 0,5Nm 0,5 x 3,5mm 								
Indice de protection:	Face avant IP54, Bornes IP20									
Poids:	270 gr.									
Afficheur										
Type:	Graphic rétroéclairage 1,8 pouces (256x128)									
Alimentation axiliaire										
Dérivée par le prises de tension (Auto-alimentée)										
Mesure										
Reseau triphasé 3 et 4 fils										
Tension (TRMS)										
Mesure directe										
Tension triphasée nominale Un:	3x230V~ / 3x400V~ ± 15%									
Autoconsommation circuit de tension:	Max. 1,8VA triphasée									
Classe de précision de tension:	0,5									
Courant (TRMS) Mesure directe	4 121 08 I _{min} 12,5A - I _{ref} 250A - I _{max} 750A									
	4 121 09 I _{min} 32,5A - I _{ref} 650A - I _{max} 1900A									
	4 121 10 I _{min} 65A - I _{ref} 1300A - I _{max} 3900A									
	4 121 11 I _{min} 125A - I _{ref} 2500A - I _{max} 7500A									
Classe de précision de courant:	1									
Fréquence										
Fréquence nominale	F _n 50Hz; 60Hz									
Variation admise	45...65Hz									
Energies										
Classe de précision Energie Active:	1 (EN 62053-21)									
Classe de précision Energie Réactive:	2 (EN 62053-23)									

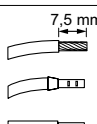
• Caractéristiques techniques

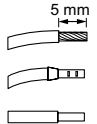
Entrée numérique	
Tension:	12-24V DC
Courant:	Max. 10 mA
Conditions d' utilisation	
Température de fonctionnement:	(-20°C) ÷ (60°C)
Température de stockage:	(-25°C) ÷ (70°C)
Humidité:	Convient pour les climats tropicaux
Dissipation thermique:	< 5 W
Environnement mécanique:	M1
Environnement électromagnétique:	E2
Humidité relative:	95% sans condensation (EN50472-1)
Installation:	Installation du compteur dans un panneau IP51
Utilisation:	Utilisation interne

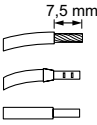
Marquage CE	
<p>Le produit est répondeur aux:</p> <ul style="list-style-type: none"> • Dispositions de la directive européenne sur la compatibilité électromagnétique (CEM) n° 2014/30/UE • A directive basse tension n° 2014/35/EU. • A directive 2011/65/UE modifiée par directive 2015/863 (RoHS 2). 	
Compatibilité électromagnétique	
Essais conformément à IEC/EN 62052-11 - EN 50470-1	
Isolation (IEC/EN 62052-11, IEC/EN 62053-21)	
Catégorie de mesure:	III
Degré de pollution:	2
Tension d' isolation, Ui:	300V Phase-Terre
Tension de choc assignée:	- Entrée de mesure / Entrée I/O numérique: onda 1,2 / 50µs 0,5 J: 6kV tension alternatif 50Hz / 1 min.: 3kV -Tous les circuits /Terre: tension alternatif 50Hz / 1 min.: 4kV
Face avant:	Classe II

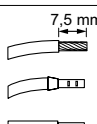
• Technische Daten

Gehäuse										
Abmessung (L x H x T)	71,2 x 92,4 x 66mm									
Anschlüsse	<table border="1" style="width: 100%; border-collapse: collapse;"> <tr> <td style="text-align: center;">  1 C 2 </td> <td style="text-align: center;">  5 mm MAX 1 x 1mm² 1 x 1mm² 1 x 1mm² </td> <td style="text-align: center;"> Recommended torque 0,2Nm 0,5 x 3mm  </td> </tr> <tr> <td style="text-align: center;">  V1-V2-V3-N 2 5 8 11 </td> <td style="text-align: center;">  7,5 mm MAX 1 x 1,5mm² 1 x 2,5mm² 1 x 1,5mm² </td> <td style="text-align: center;"> Recommended torque 0,5Nm 0,5 x 3,5mm COMBI PH1  </td> </tr> <tr> <td style="text-align: center;">  N-V3-V2-V1 </td> <td style="text-align: center;">  7,5 mm MAX 1 x 1,5mm² 1 x 2,5mm² 1 x 1,5mm² </td> <td style="text-align: center;"> Recommended torque 0,5Nm 0,5 x 3,5mm  </td> </tr> </table>	 1 C 2	 5 mm MAX 1 x 1mm ² 1 x 1mm ² 1 x 1mm ²	Recommended torque 0,2Nm 0,5 x 3mm 	 V1-V2-V3-N 2 5 8 11	 7,5 mm MAX 1 x 1,5mm ² 1 x 2,5mm ² 1 x 1,5mm ²	Recommended torque 0,5Nm 0,5 x 3,5mm COMBI PH1 	 N-V3-V2-V1	 7,5 mm MAX 1 x 1,5mm ² 1 x 2,5mm ² 1 x 1,5mm ²	Recommended torque 0,5Nm 0,5 x 3,5mm 
 1 C 2	 5 mm MAX 1 x 1mm ² 1 x 1mm ² 1 x 1mm ²	Recommended torque 0,2Nm 0,5 x 3mm 								
 V1-V2-V3-N 2 5 8 11	 7,5 mm MAX 1 x 1,5mm ² 1 x 2,5mm ² 1 x 1,5mm ²	Recommended torque 0,5Nm 0,5 x 3,5mm COMBI PH1 								
 N-V3-V2-V1	 7,5 mm MAX 1 x 1,5mm ² 1 x 2,5mm ² 1 x 1,5mm ²	Recommended torque 0,5Nm 0,5 x 3,5mm 								
Schutzklasse:	Frontal IP54, Klemmen IP20									
Gewicht:	270 gr.									
Display										
Typ:	Rückbeleuchtete Anzeige 1.8 Zoll (256x128)									
Hilfsspannung										
Abgeleitet von den Spannungsanschlüssen (Selbstversorgung):										
Messung										
Drehstromnetz 3 und 4 Leiter										
Spannung (TRMS) Direkte Messung										
Dreiphasige Nennspannung Un:	3x230V~ / 3x400V~ ± 15%									
Selbstverbrauch Spannungskreis	Max. 1,8VA dreiphasig									
Genauigkeitsklasse Spannungs	0,5									
Strom (TRMS) Direkte Messung	4 121 08 $I_{min} 12,5A - I_{ref} 250A - I_{max} 750A$ 4 121 09 $I_{min} 32,5A - I_{ref} 650A - I_{max} 1900A$ 4 121 10 $I_{min} 65A - I_{ref} 1300A - I_{max} 3900A$ 4 121 11 $I_{min} 125A - I_{ref} 2500A - I_{max} 7500A$									
Genauigkeitsklasse Strom	1									
Frequenz										
Nennfrequenz	F_n 50Hz; 60Hz									
Spannungsanschlussklemmen	45...65Hz									
Energie										
Genauigkeitsklasse Wirkenergie:	1 (EN 62053-21)									
Genauigkeitsklasse Blindenergie:	2 (EN 62053-23)									

• Technische Daten







Digitaleingänge	
Spannung:	12-24V DC
Strom:	Max. 10 mA
Gebrauchsbedingungen	
Betriebstemperatur:	(-20°C) ÷ (60°C)
Lagertemperatur:	(-25°C) ÷ (70°C)
Feuchtigkeit:	Geeignet für den Einsatz in tropischem Klima
Maximale Verlustleistung:	< 5 W
Mechanische Umgebung:	M1
Elektromagnetische Umgebung:	E2
Relative Feuchte:	95% ohne Kondensation (EN50472-1)
Installieren:	Montage des Zählers innerhalb eines IP51-Panels
Ausnutzung:	Interne Verwendung

CE-Kennzeichnung	
<p>Das Gerät entsprechen:</p> <ul style="list-style-type: none"> • Den Bestimmungen der Europäischen Richtlinie über die elektromagnetische Verträglichkeit (EMV) Nr. 2014/30/EU • Der Niederspannungsrichtlinie 2014/35/EU • Der Richtlinie 2011/65/EG geändert durch Richtlinie 2015/863 (RoHS 2) 	
Elektromagnetische Verträglichkeit	
Prüfungen gemäß IEC/EN 62052-11 - EN 50470-1	
Isolation (IEC/EN 62052-11, IEC/EN 62053-21)	
Messkategorie:	III
Verschmutzungsgrad:	2
Isolationsspannung, Ui:	300V Phase-Erde
Impulsdauer:	-Messeingänge / Digitale I / O-Eingänge: Welle 1,2 / 50µs 0,5 J: 6kV Wechselspannung 50Hz / 1 min.: 3kV -Alle Stromkreise /Masse Wechselspannung 50Hz / 1 min.: 4kV
Frontfläche:	Klasse II

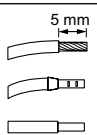
• Technische Daten

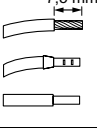
Konformität mit IEC 61557-12 Ausgabe 1 (08/2007)			
Eigenschaften des PMD			
Art des Merkmals	Wert des Feature	Andere Funktionen komplementär	
Bewertungsfunktion der Qualität der Stromversorgung	-	-	
Einstufung der PMD	SD	-	
Temperatur	K55	-	
Luftfeuchtigkeit + Höhe	Standardbedingungen	-	
Merkmale der Funktionen			
Symbole der Funktionen	Funktionsklasse nach IEC 61557-12	Messbereich (Richtigkeit)	Andere Funktionen komplementär
P	1	* Siehe Tabellen Strom (TRMS) Seite 34	
Q_V	2		
S_A	1		
E_a	1 (IEC/EN 62053-21)		
E_{rV}	2 (IEC/EN 62053-23)		
I	1		
I_N, I_{Nc}	3		
E_{apA}, E_{apV}	1 (IEC/EN 62053-21)	-	
f	± 0,5 Hz	45 ÷ 65 Hz	
U	0,5	195 ÷ 295 V (Ph/N)	
P_{Fa}, P_{FV}	0,5	0,5 ind ÷ 0,8 cap	
P_{st}, P_{It}	-	-	
U_{dip}	-	-	
U_{swl}	-	-	
U_{tr}	-	-	
U_{int}	-	-	
U_{nba}	-	-	
U_{nb}	-	-	
U_h	-	-	
THD_u	5	> 1,5 %	
THD - R_u	-	-	
I_h	-	-	
THD_i	5	> 3 %	
THD-R_i	-	-	
M_{sv}	-	-	

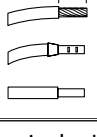
• Características técnicas

Caja	
Dimensiones (l x h x p)	71,2 x 92,4 x 66mm
Conexión	 1 C 2  5 mm MAX 1 x 1mm ² 1 x 1mm ² 1 x 1mm ² Recommended torque 0,2Nm 0,5 x 3mm 
	 V1-V2-V3-N 2 5 8 11  7,5 mm MAX 1 x 1,5mm ² 1 x 2,5mm ² 1 x 1,5mm ² Recommended torque 0,5Nm 0,5 x 3,5mm COMBI PH1 
	 N-V3-V2-V1  7,5 mm MAX 1 x 1,5mm ² 1 x 2,5mm ² 1 x 1,5mm ² Recommended torque 0,5Nm 0,5 x 3,5mm 
Indice de protección:	Fronte IP54, Terminales IP20
Peso:	270 gr.
Visualizador	
Type:	Gráfico retroiluminado 1,8 pulgadas (256x128)
Alimentación auxiliar	
Derivada de la toma de presión (autoalimentado)	
Medidas	
Red trifásica 3 o 4 hilos	
Tensión (TRMS)	
Medida directa	
Tensión trifásica nominal Un:	3x230V~ / 3x400V~ ± 15%
Autoconsumo circuito de tensión:	Máx. 1,8VA trifásica
Clase de precisión de tensión:	0,5
Corriente (TRMS) Medida directa	4 121 08 I _{min} 12,5A - I _{ref} 250A - I _{max} 750A
	4 121 09 I _{min} 32,5A - I _{ref} 650A - I _{max} 1900A
	4 121 10 I _{min} 65A - I _{ref} 1300A - I _{max} 3900A
	4 121 11 I _{min} 125A - I _{ref} 2500A - I _{max} 7500A
Clase de precisión de corriente:	1
Frecuencia	
Frecuencia nominal	F _n 50Hz; 60Hz
Variación admitida	45...65Hz
Energía	
Clase de precisión Energía Activa:	1 (EN 62053-21)
Clase de precisión Energía Reactiva :	2 (EN 62053-23)

• Características técnicas

Entradas digitales	
Tensión:	12-24V DC
Corriente:	Máx. 10 mA
Condiciones de uso	
Temperatura de funcionamiento:	(-20°C) ÷ (60°C)
Temperatura de almacenaje:	(-25°C) ÷ (70°C)
Humedad:	Apto para la utilización en un clima tropical
Máxima potencia disipada:	< 5 W
Entorno mecánico:	M1
Entorno electromagnético:	E2
Humedad relativa:	95% sin condensación (EN50472-1)
Instalación:	Montaje del medidor dentro de un panel IP51
Utilización:	Uso en interiores

Marcado CE	
<p>El dispositivo es conforme:</p> <ul style="list-style-type: none"> • A las disposiciones de la Directiva europea sobre la compatibilidad electromagnética (EMC) n.º 2014/30/EU • A la Directiva baja tensión n.º 2014/35/UE • A la Directiva 2011/65/EU modificada por la directiva 2015/863 (RoHS 2) 	
Compatibilidad electromagnética	
Pruebas en conformidad a IEC/EN 62052-11 - EN 50470-1	
Aislamiento (IEC/EN 62052-11, IEC/EN 62053-21)	
Categoría de medida:	III
Grado de polución:	2
Tensión de Aislamiento, Ui:	300V Fase-Tierra
Resistencia al impulso de tensión:	- Entradas de medición / Entradas digitales I/O: onda 1,2 / 50µs 0,5 J: 6kV tensión alterna 50Hz / 1 min.: 3kV -Todos los circuitos / Masa tensión alterna 50Hz / 1 min.: 4kV
Superficie frontal:	Clase II

• Características técnicas

Conformidad con IEC 61557-12 Edition 1 (08/2007)			
Características del PMD			
Tipo de característica	Valor de la característica	Otras características complementarias	
Funcion de evaluacion de la calidad de la alimentacion	-	-	
Clasificacion de los PMD	SD	-	
Temperatura	K55	-	
Humedad + Altitud	Condiciones estándar	-	
Características de las funciones			
Símbolo de las funciones	Clase de rendimiento de funcionamiento, según la norma IEC 61557-12	Rango de medición (exactitud)	Otras características complementarias
P	1	* Ver Table Corriente (TRMS) pág.37	
Q _v	2		
S _A	1		
E _a	1 (IEC/EN 62053-21)		
E _{rV}	2 (IEC/EN 62053-23)		
I	1		
I _N , I _{NC}	3		
E _{apAr} , E _{apV}	1 (IEC/EN 62053-21)	-	
f	± 0,5 Hz	45 ÷ 65 Hz	
U	0,5	195 ÷ 295 V (Ph/N)	
P _{FAr} , P _{FV}	0,5	0,5 ind ÷ 0,8 cap	
P _{str} , P _{It}	-	-	
U _{dip}	-	-	
U _{swl}	-	-	
U _{tr}	-	-	
U _{int}	-	-	
U _{nba}	-	-	
U _{nb}	-	-	
U _h	-	-	
THD _u	5	> 1,5 %	
THD - R _u	-	-	
I _h	-	-	
THD _i	5	> 3 %	
THD-R _i	-	-	
M _{sv}	-	-	

**World Headquarters and
International Department**

87045 LIMOGES CEDEX FRANCE

☎ : 33 5 55 06 87 87

Fax : 33 5 55 06 74 55

www.legrandelectric.com

Stamp installateur - installation firm's stamp