

LE12645AA

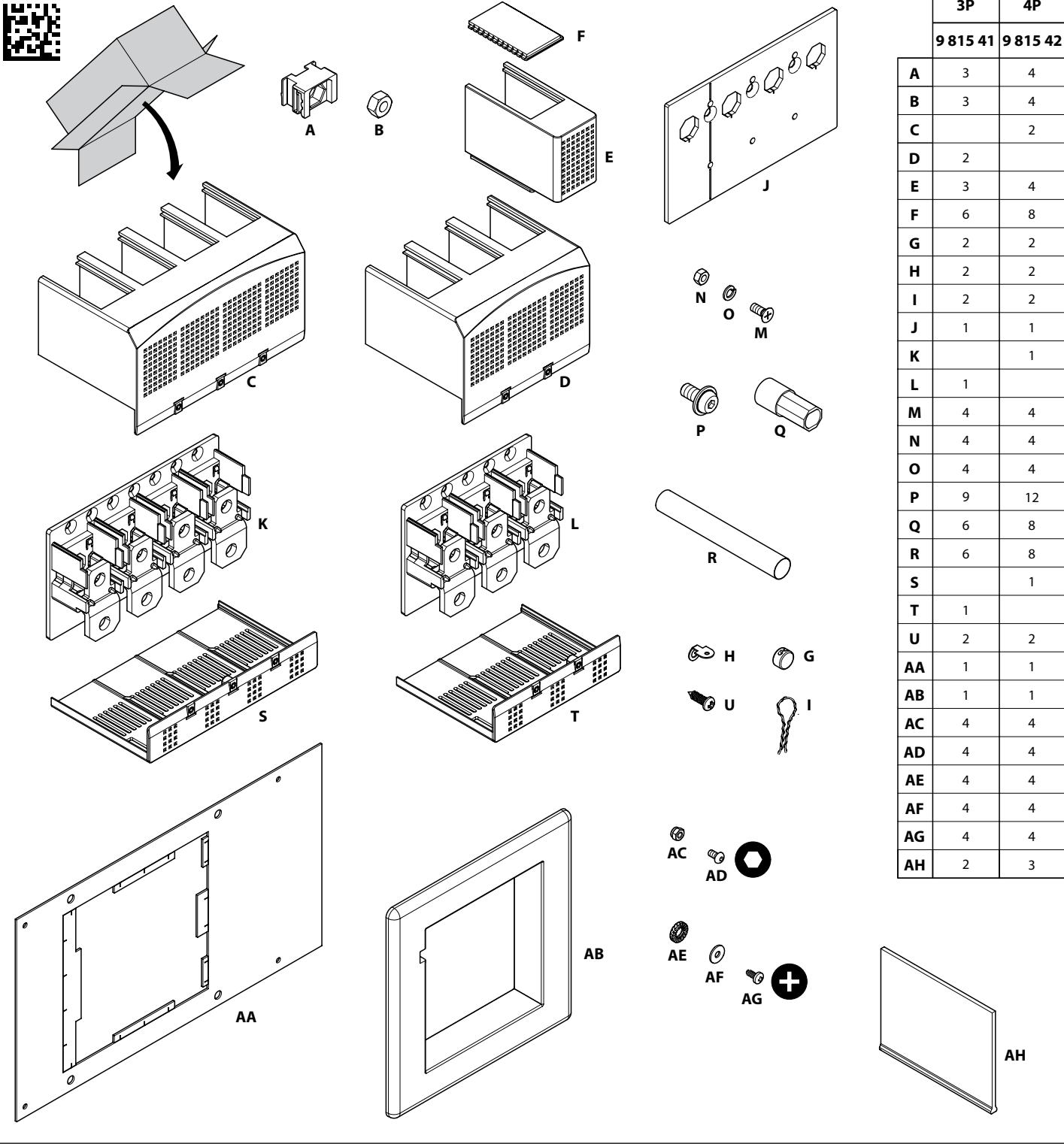

	3P	4P
	9 815 41	9 815 42
A	3	4
B	3	4
C		2
D	2	
E	3	4
F	6	8
G	2	2
H	2	2
I	2	2
J	1	1
K		1
L	1	
M	4	4
N	4	4
O	4	4
P	9	12
Q	6	8
R	6	8
S		1
T	1	
U	2	2
AA	1	1
AB	1	1
AC	4	4
AD	4	4
AE	4	4
AF	4	4
AG	4	4
AH	2	3

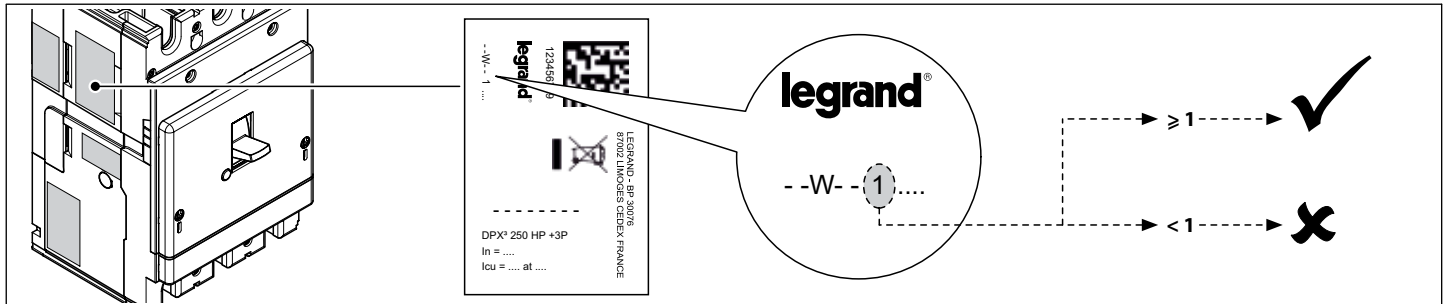

LE12645AA

DPX 250

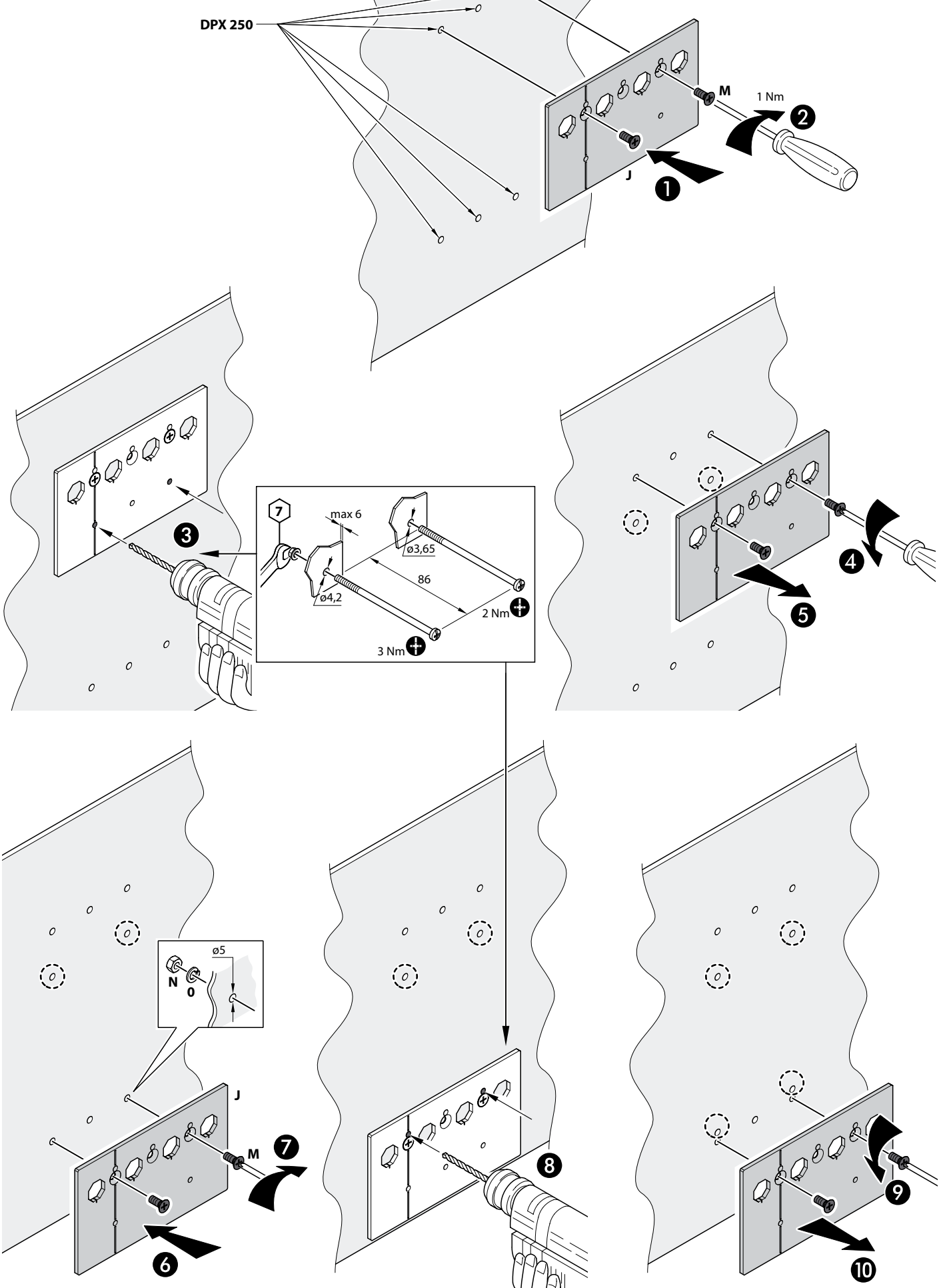
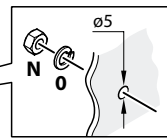

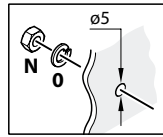
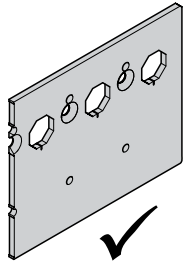
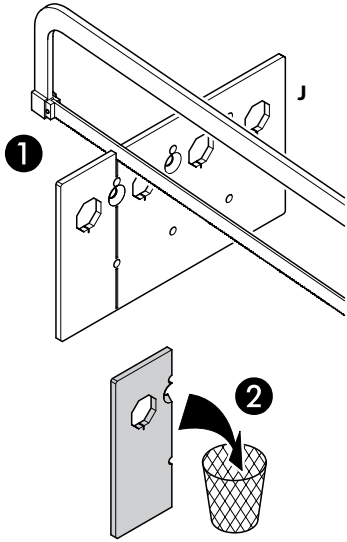

DPX 250

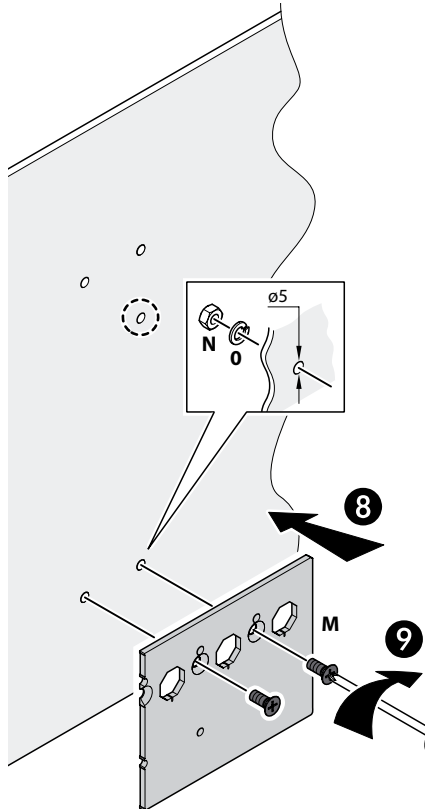
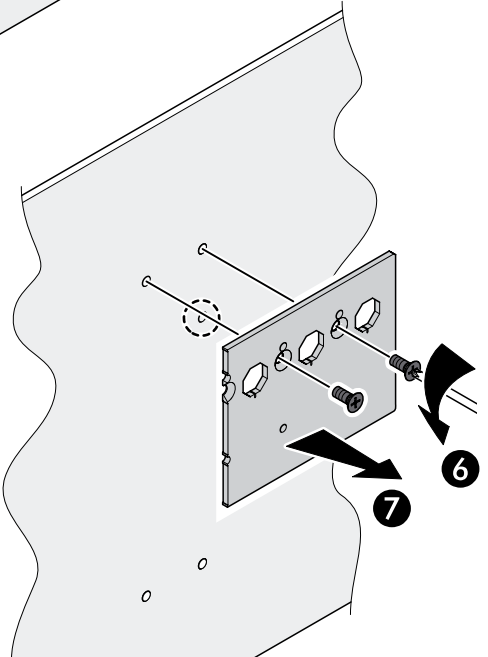
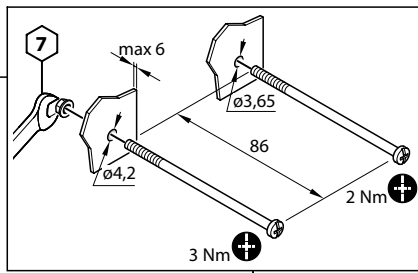
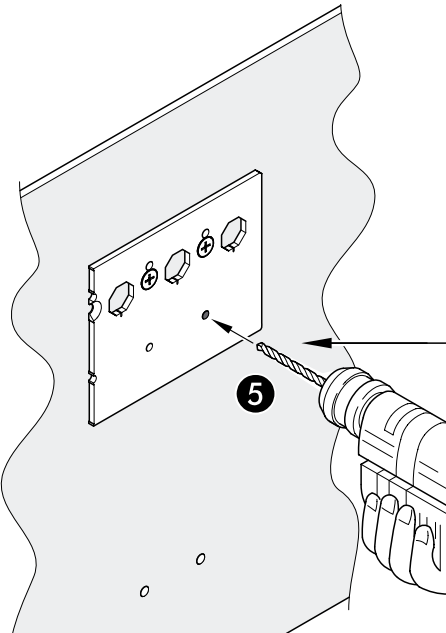
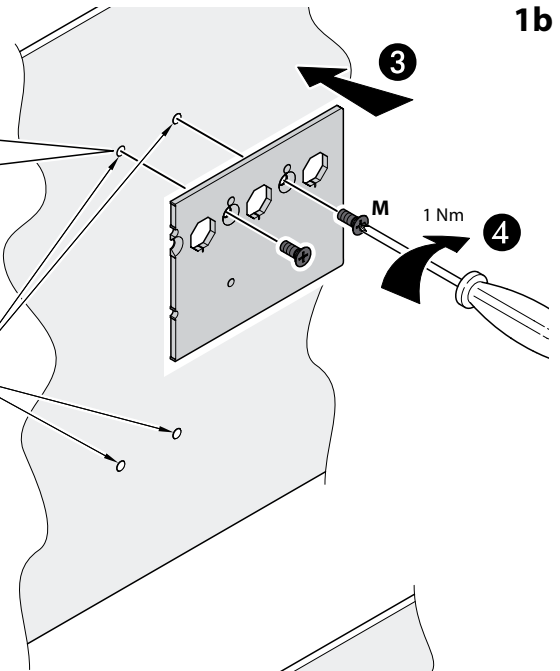

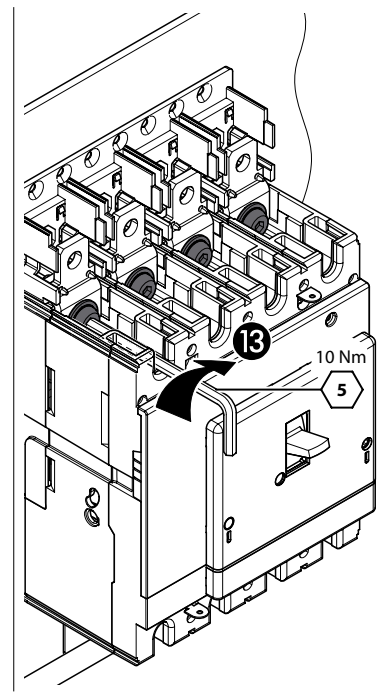
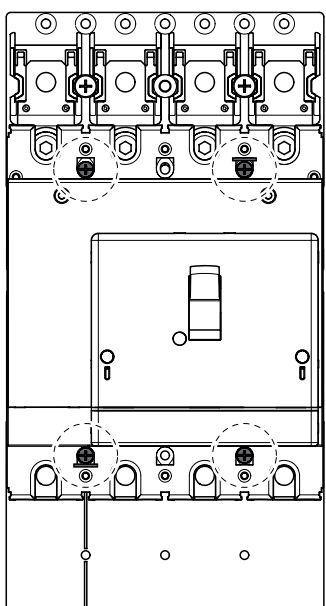
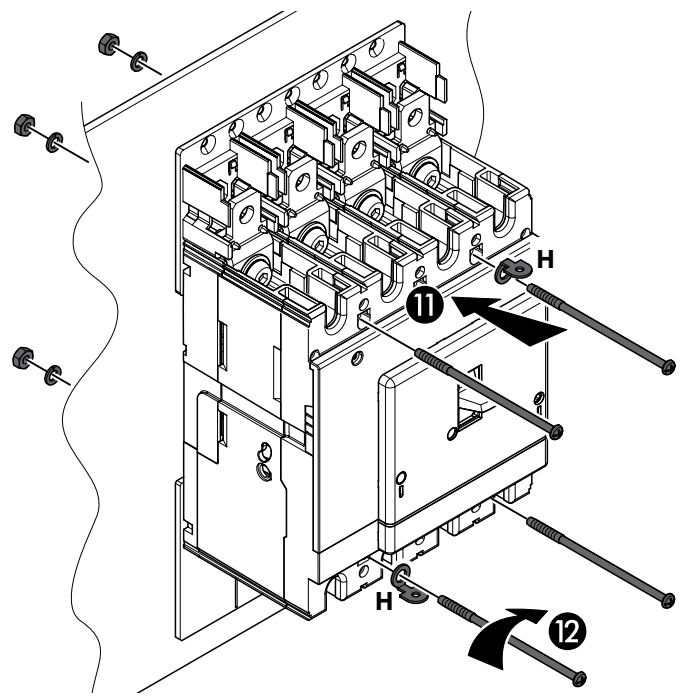
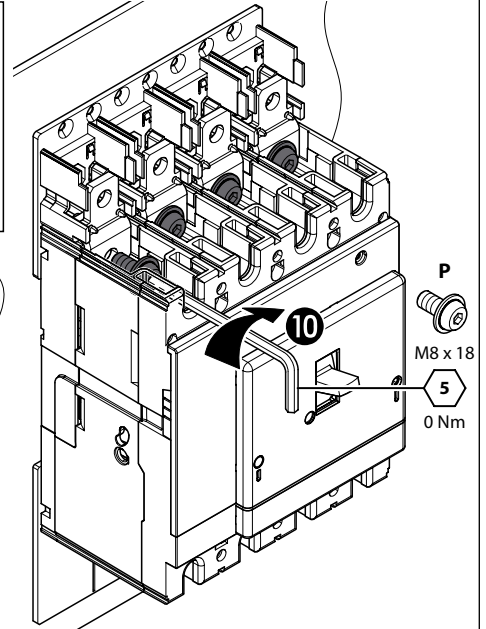
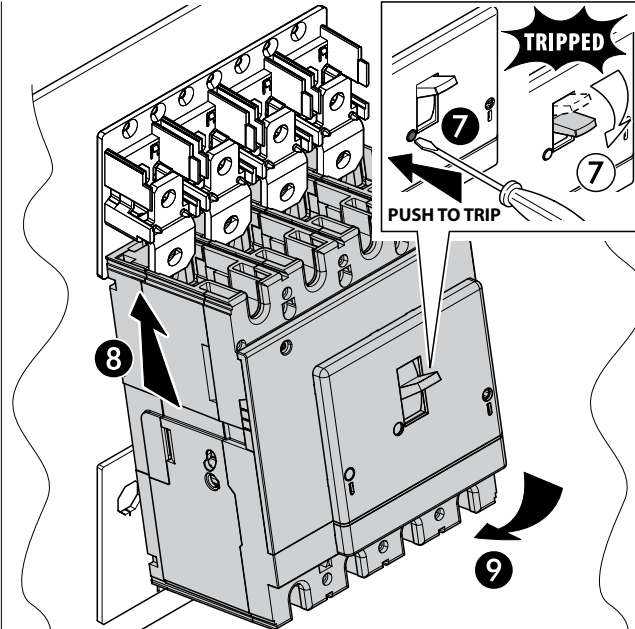
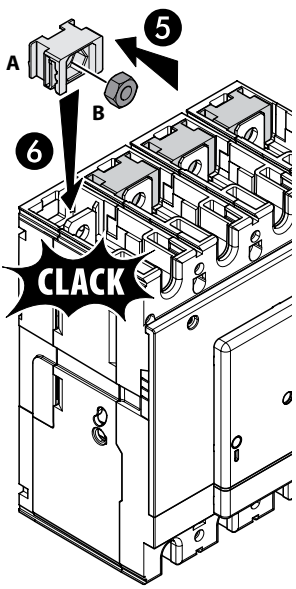
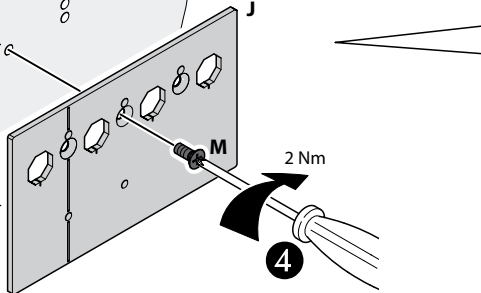
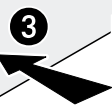
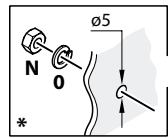
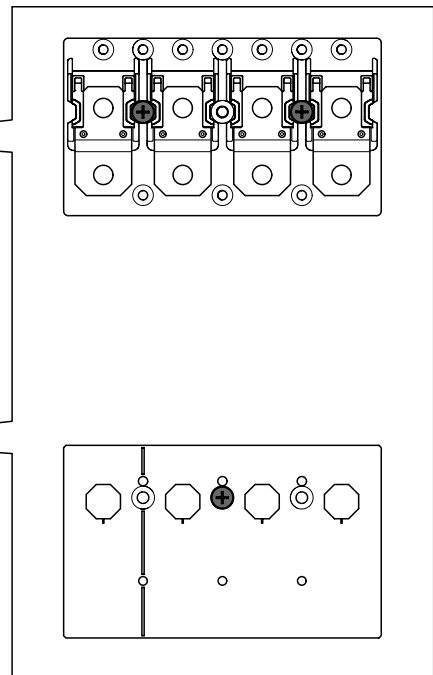
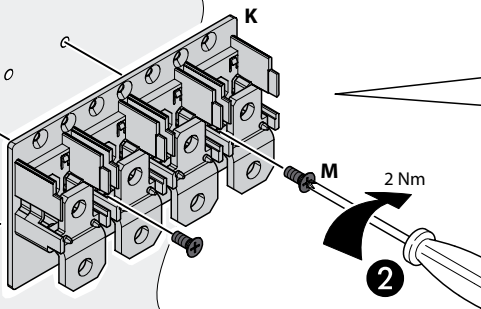
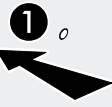
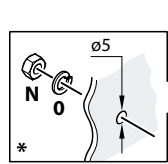

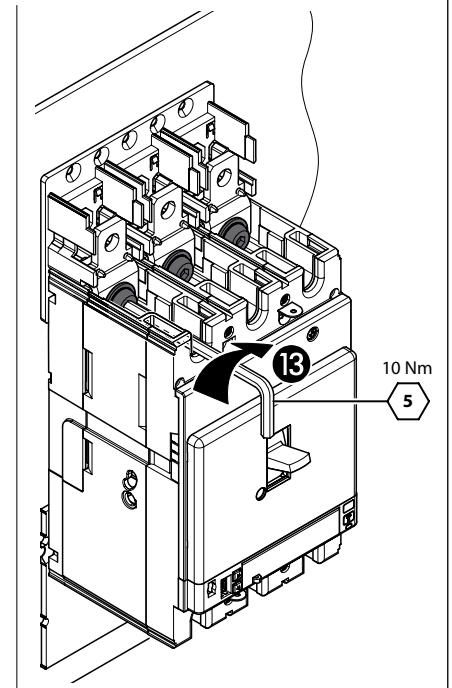
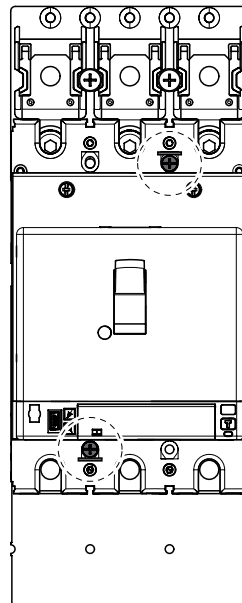
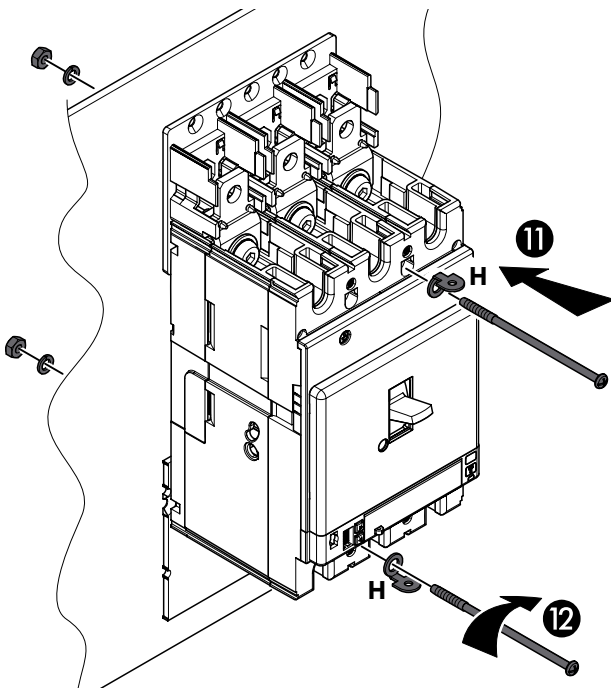
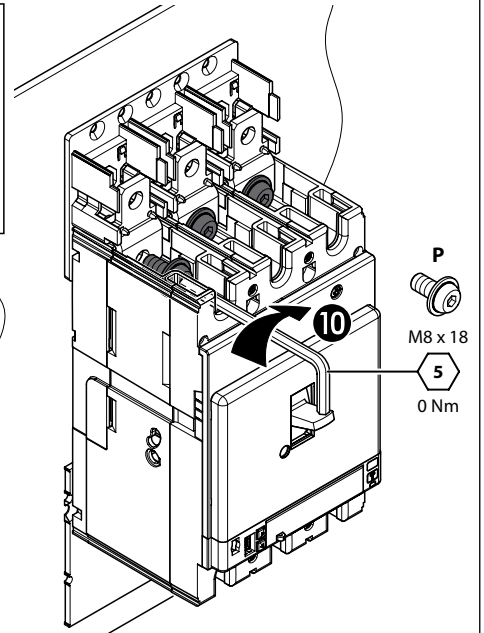
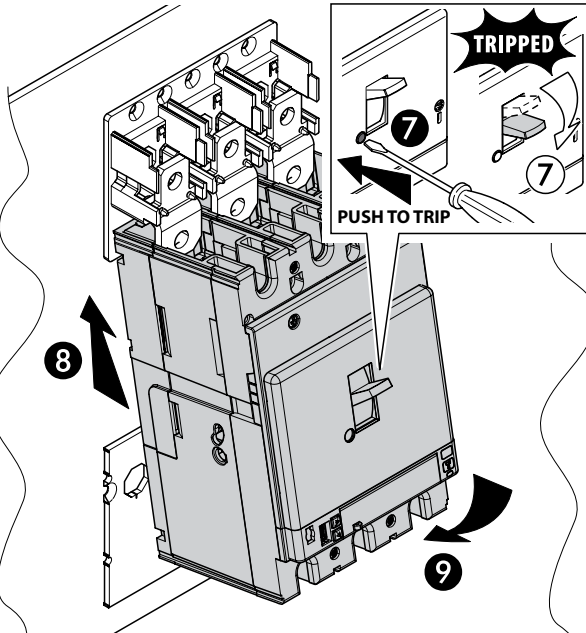
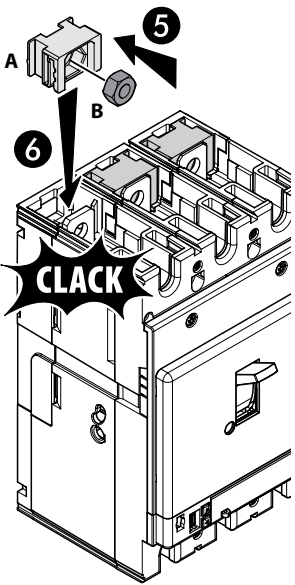
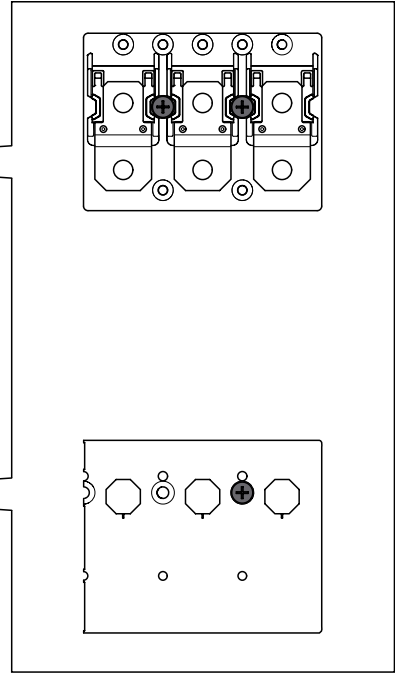
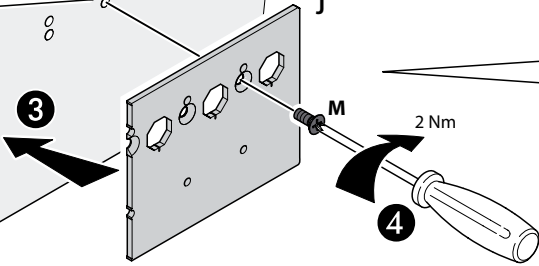
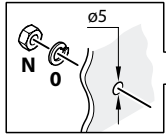
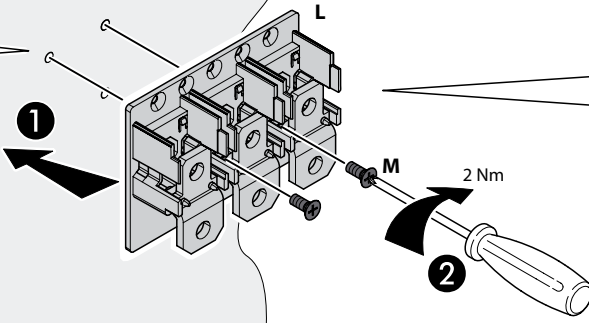
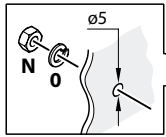

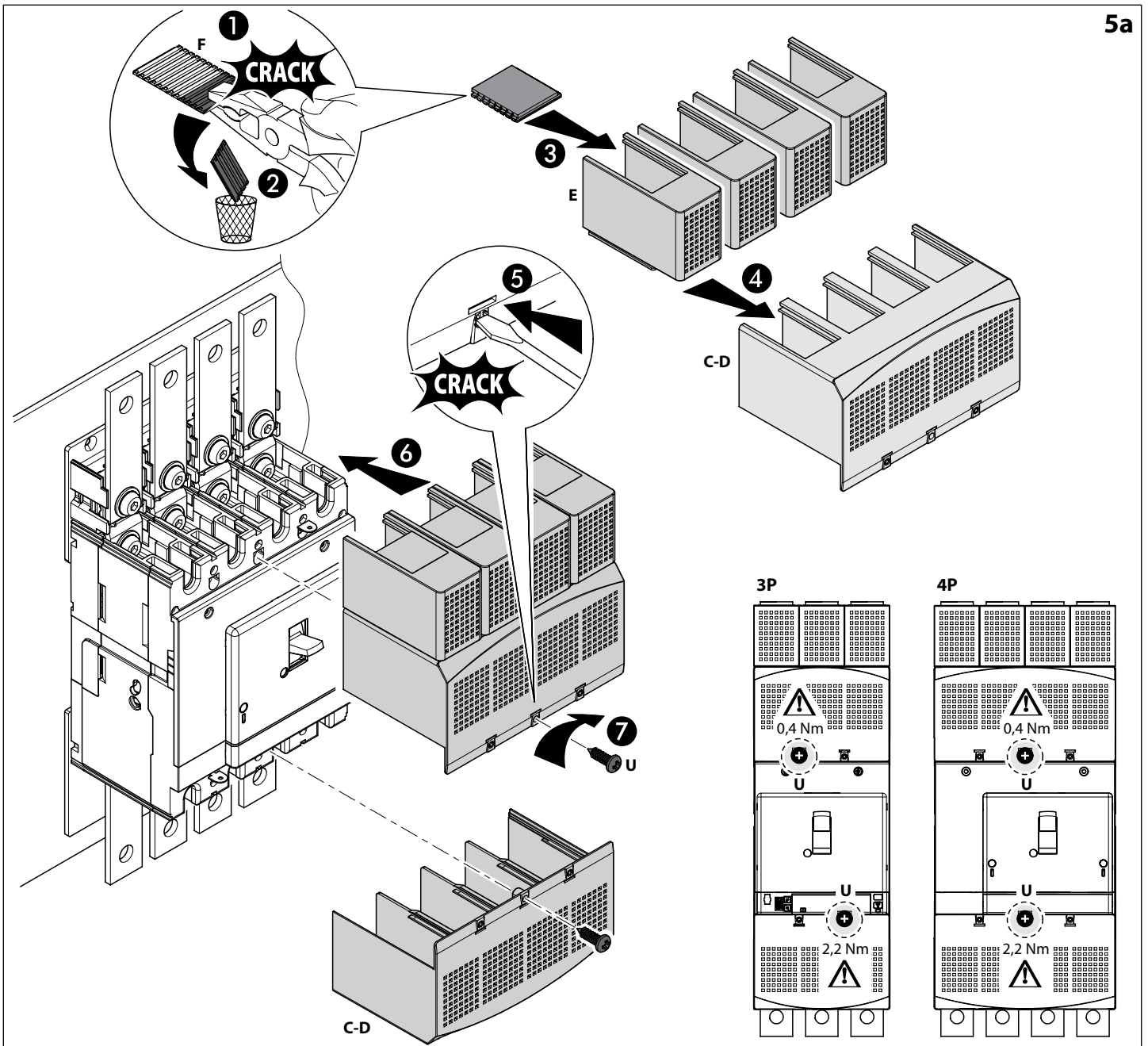
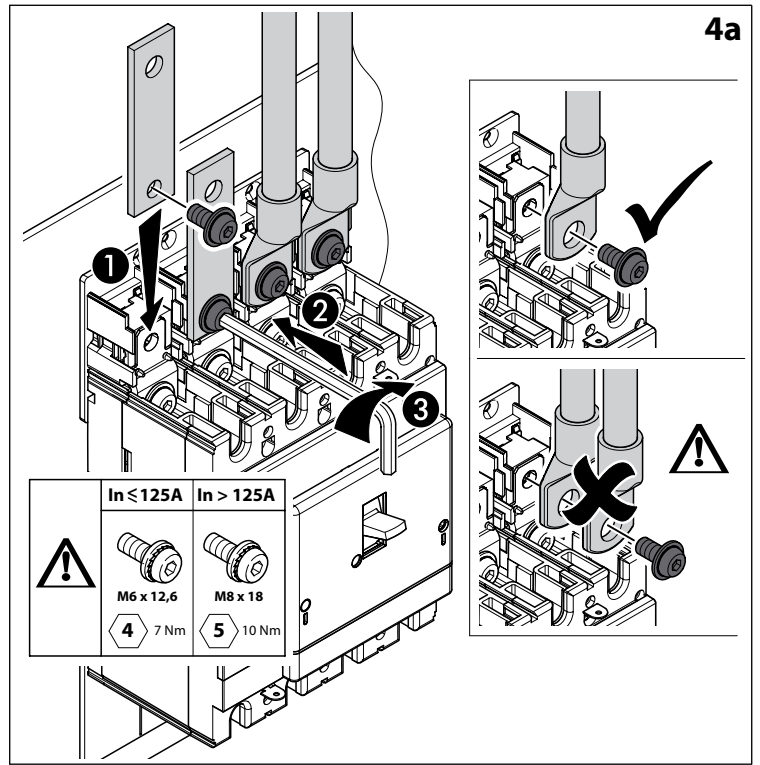
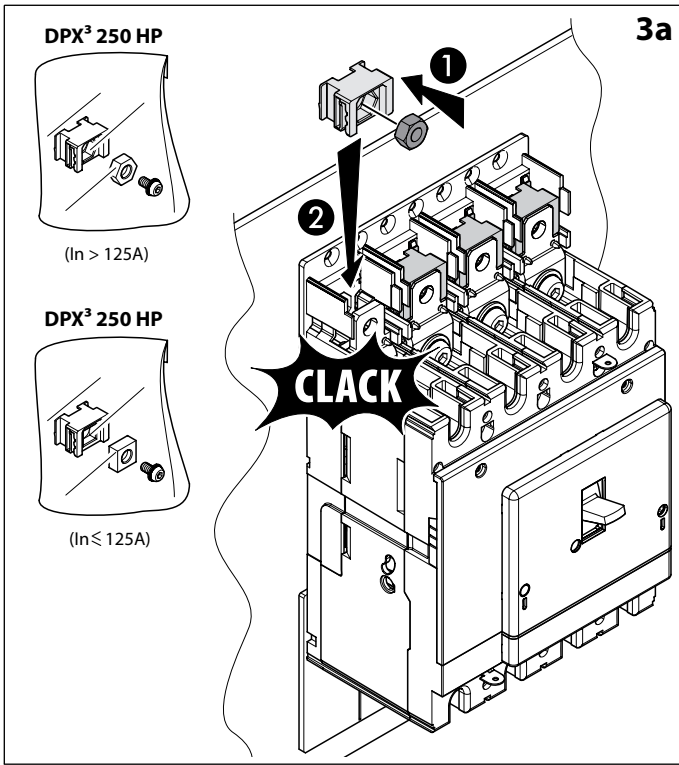

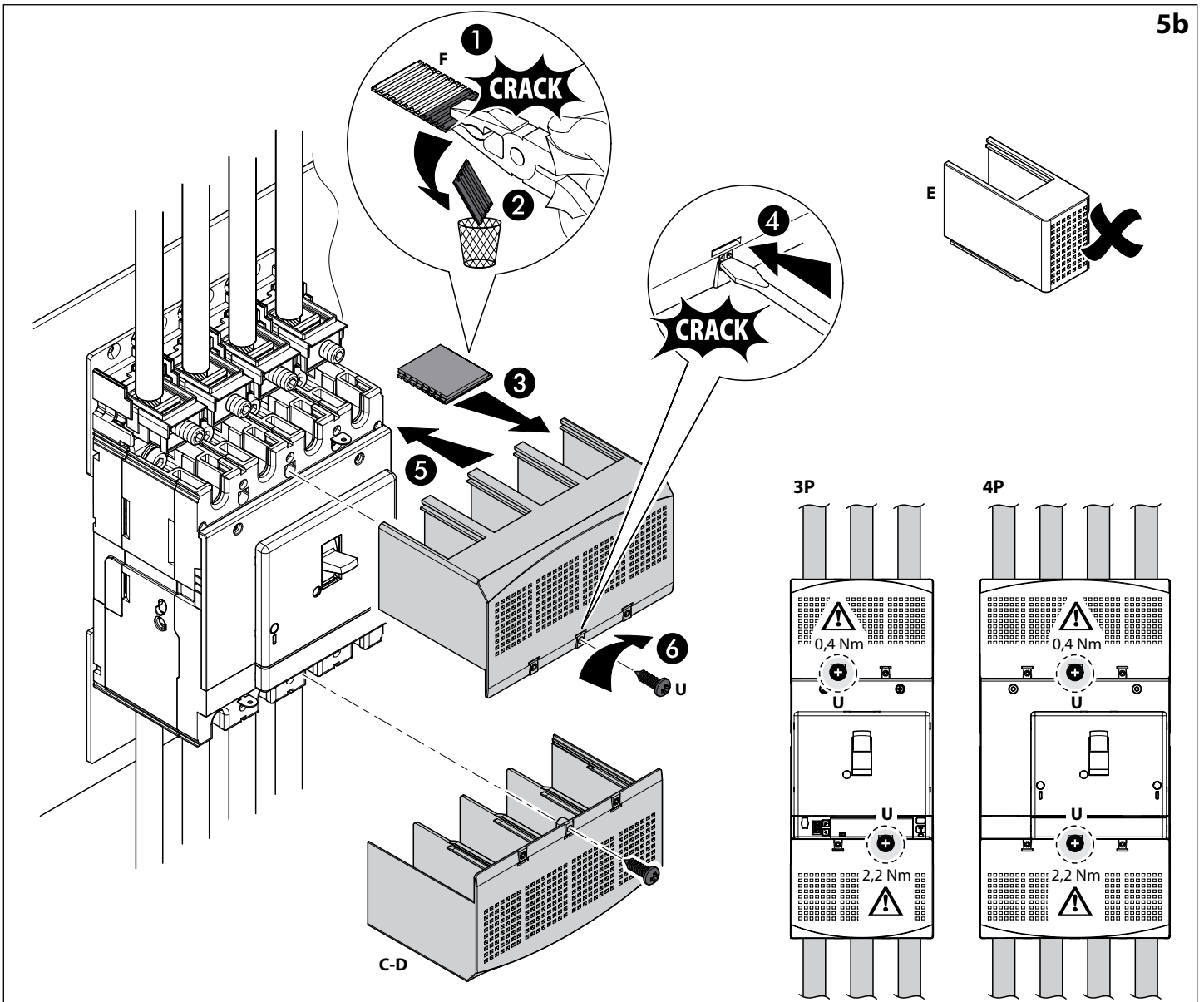
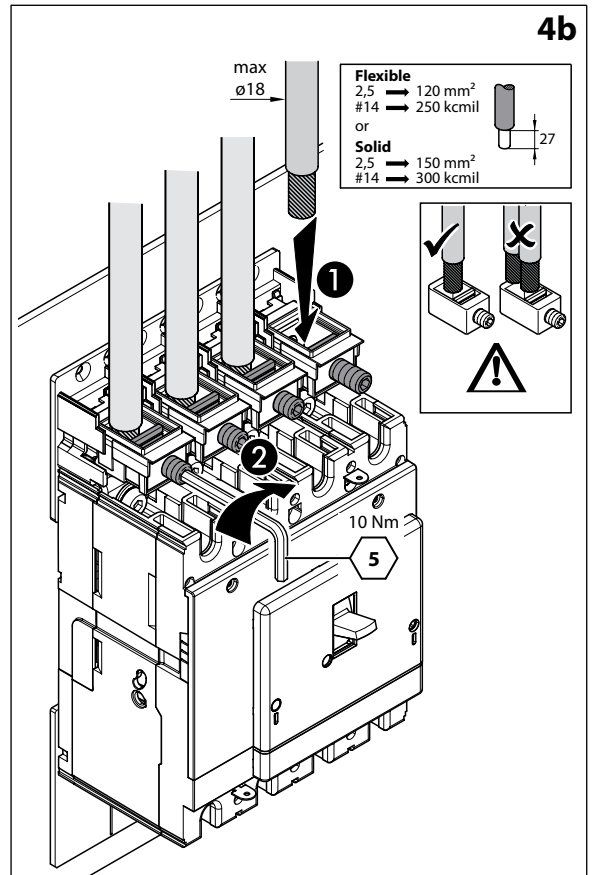
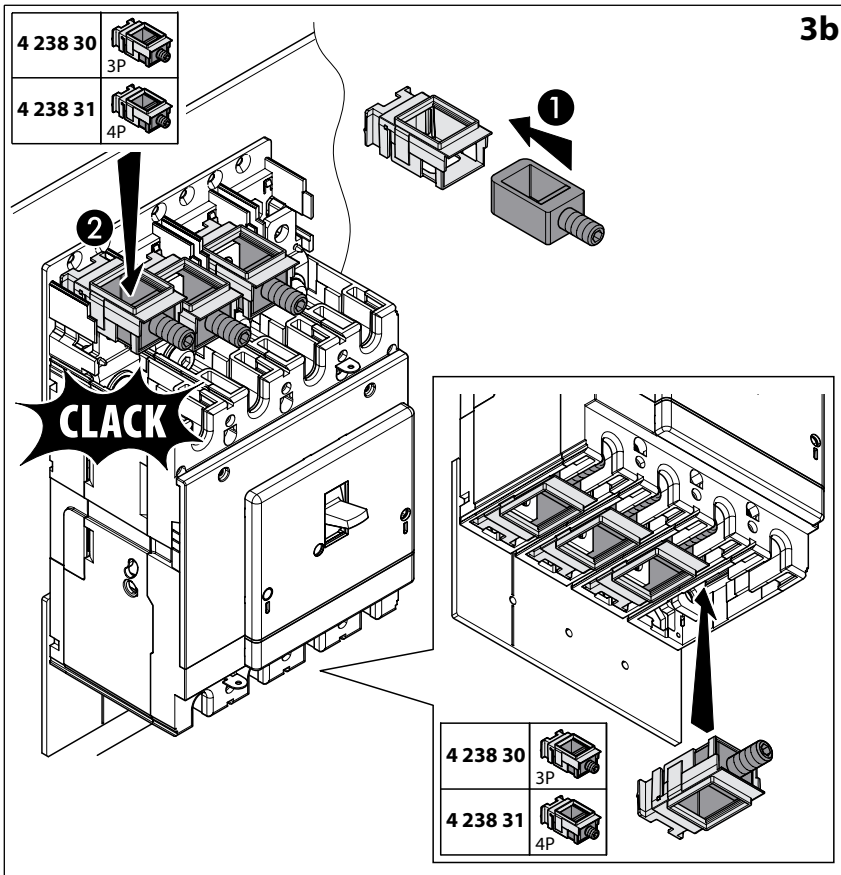

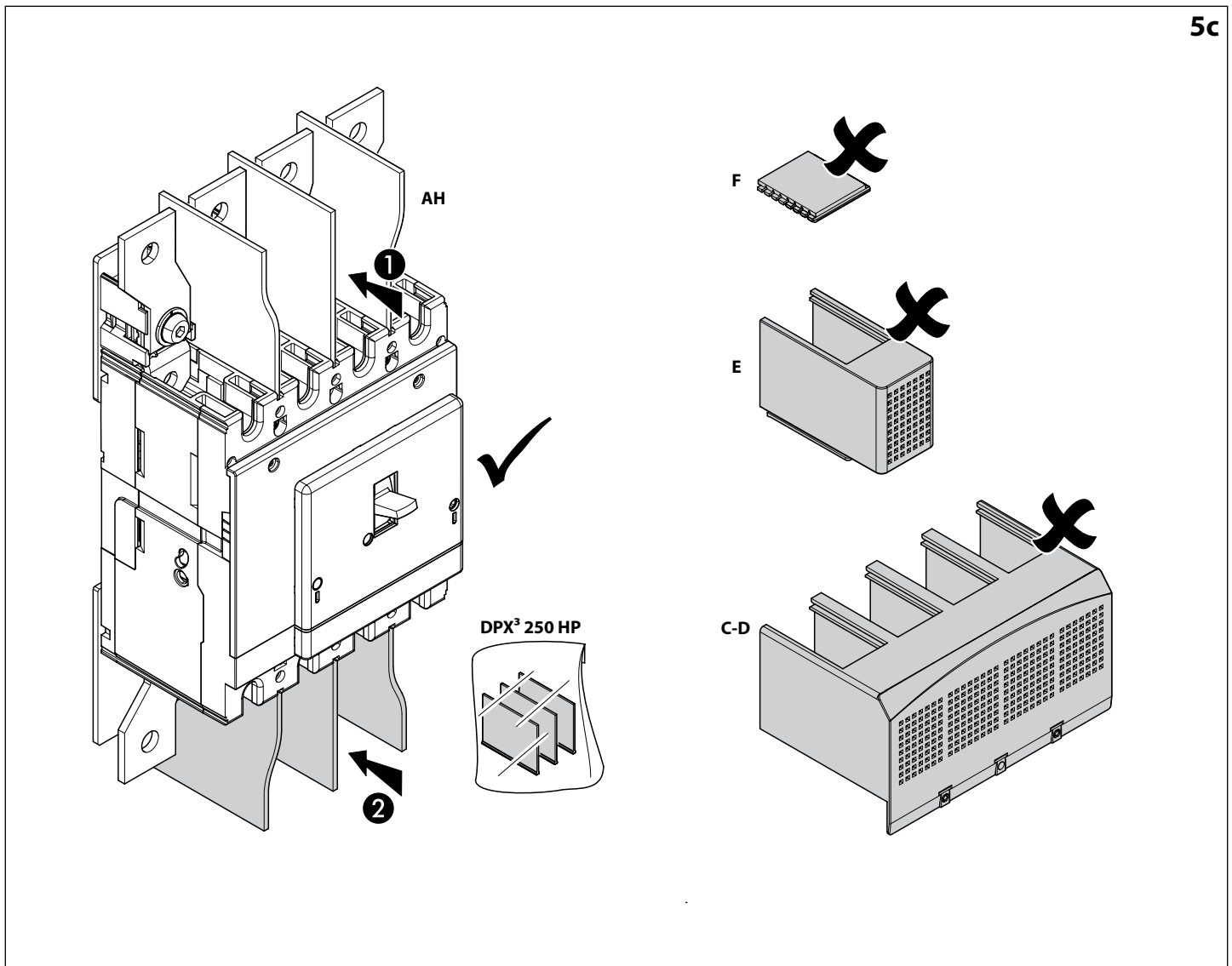
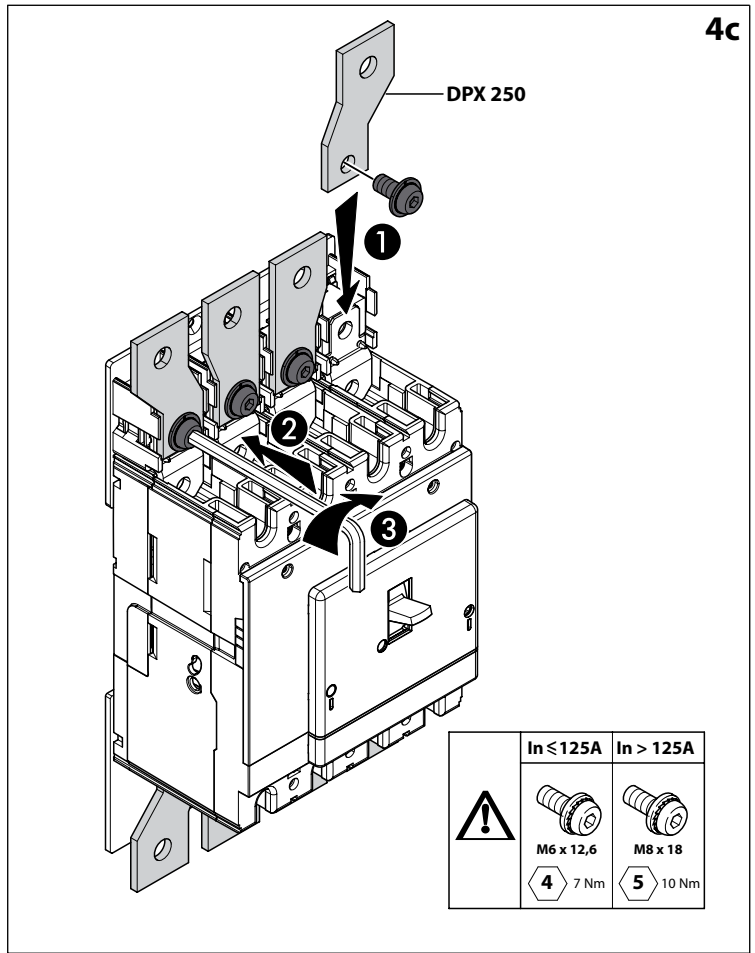
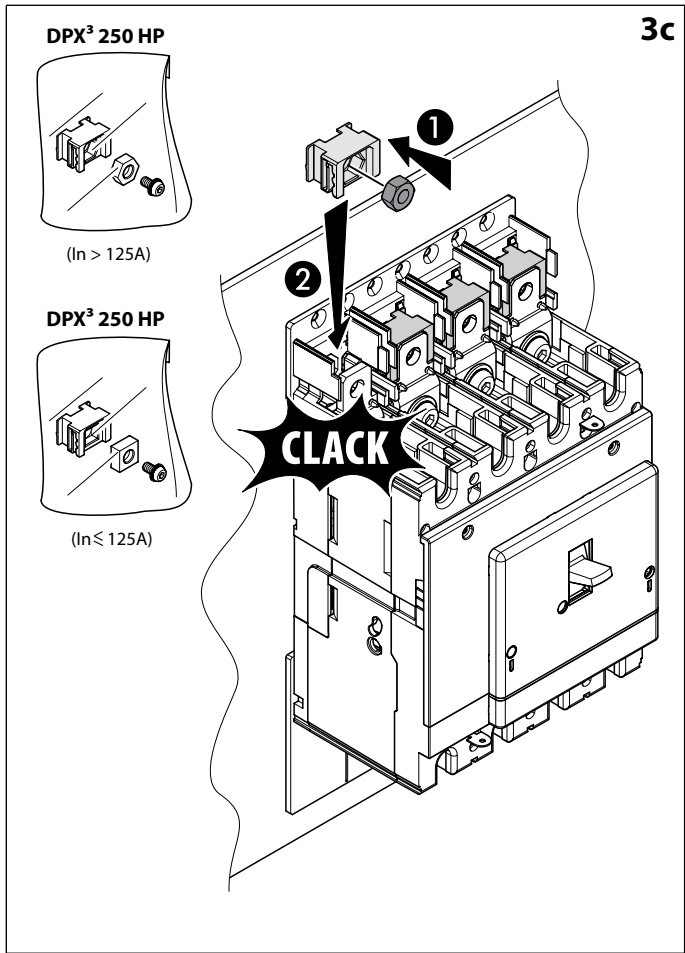



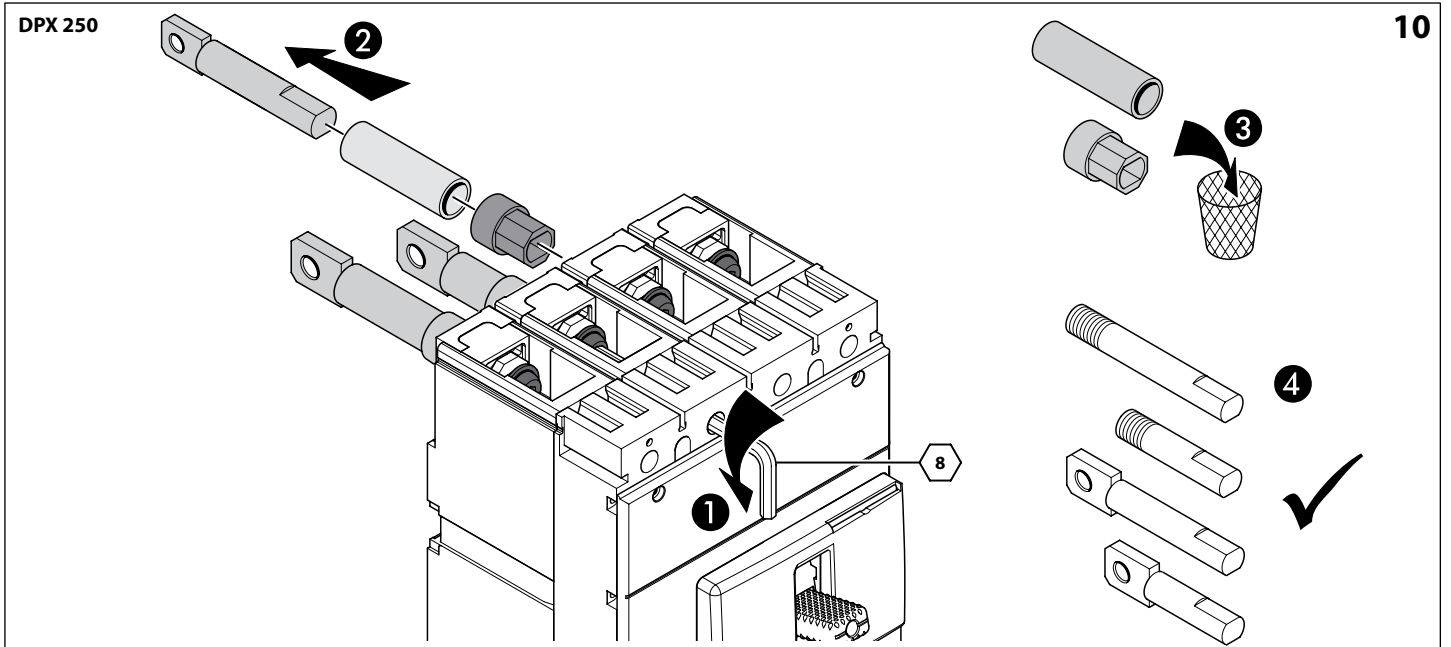
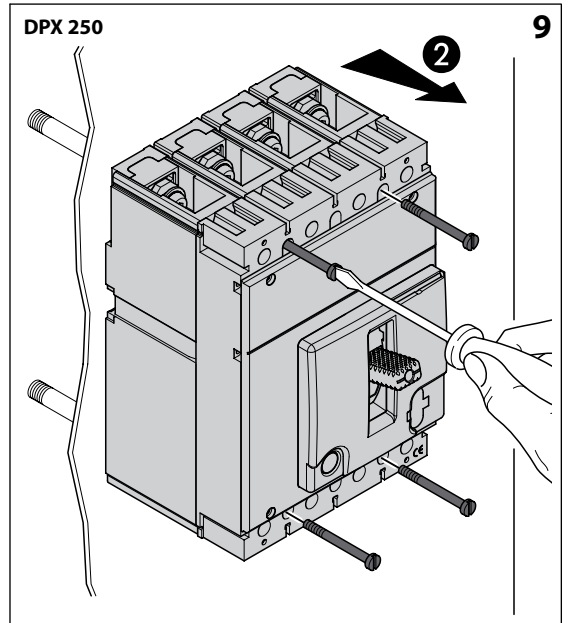
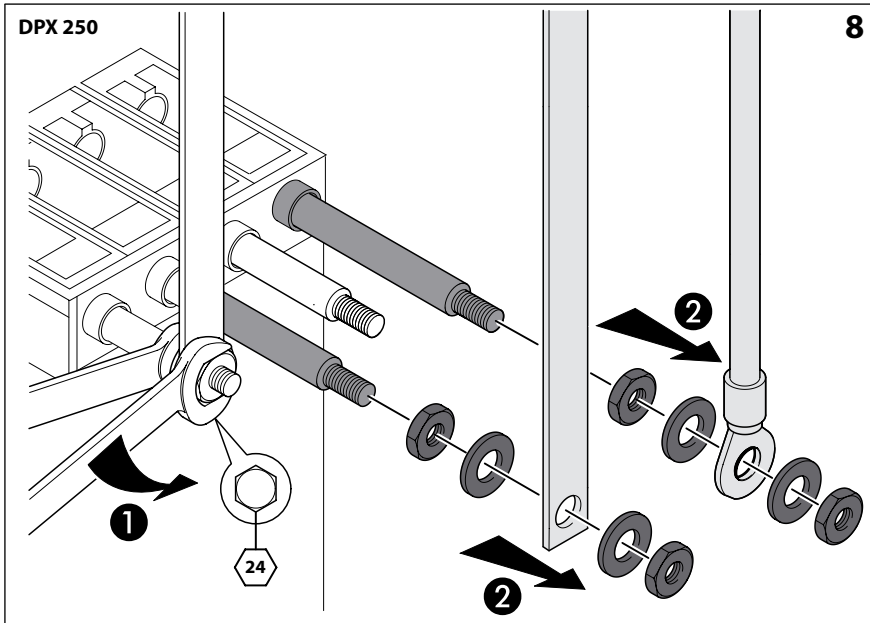
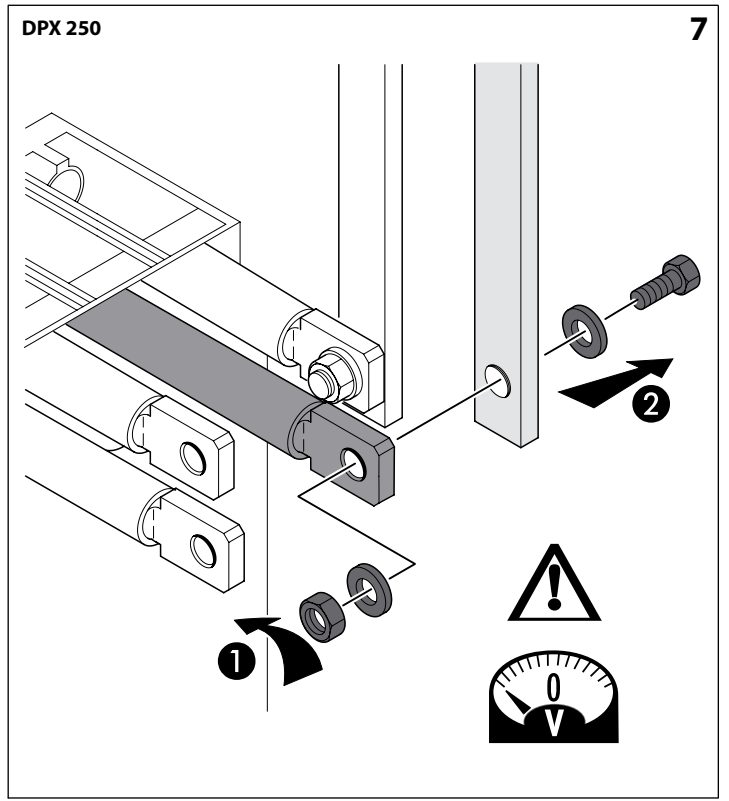
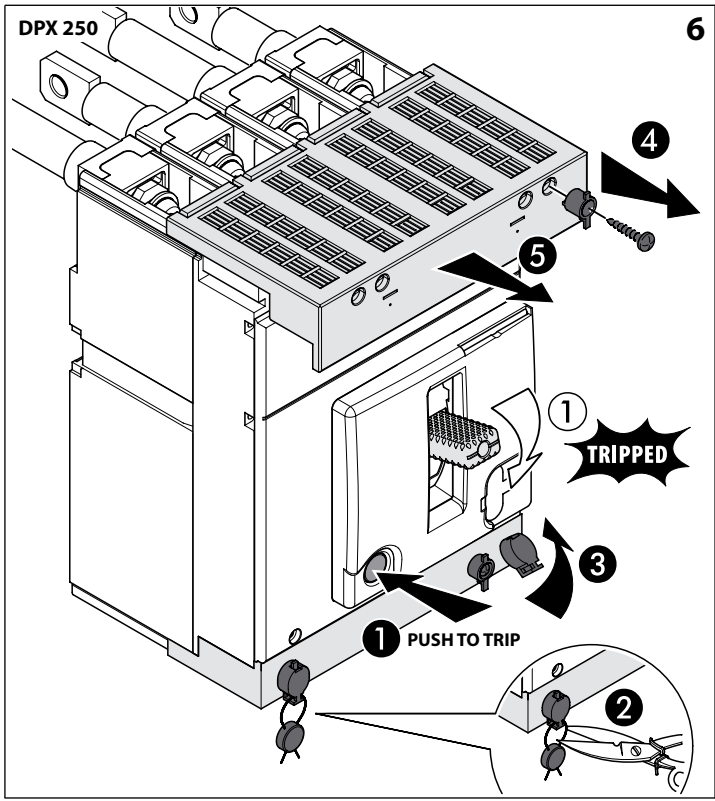

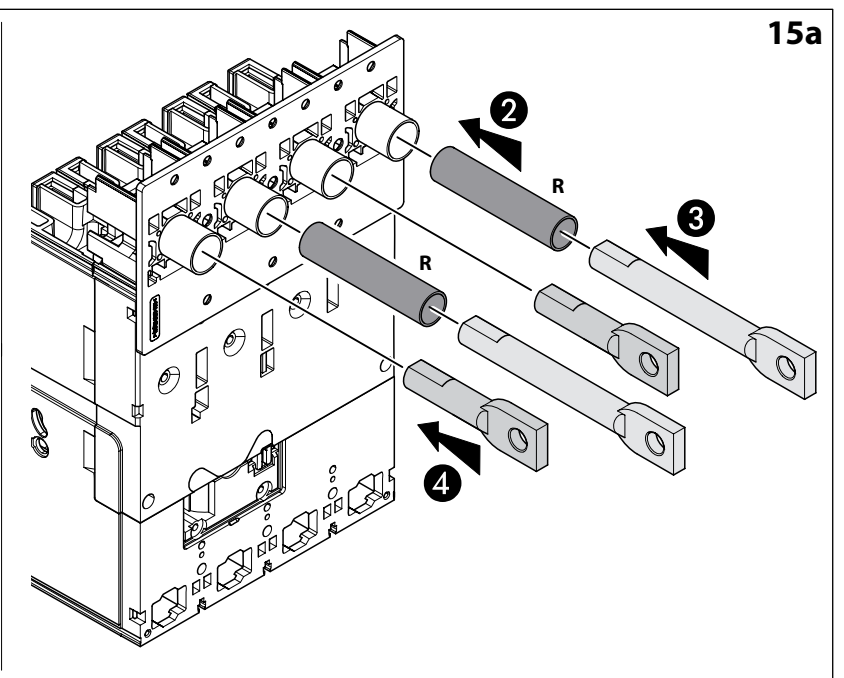
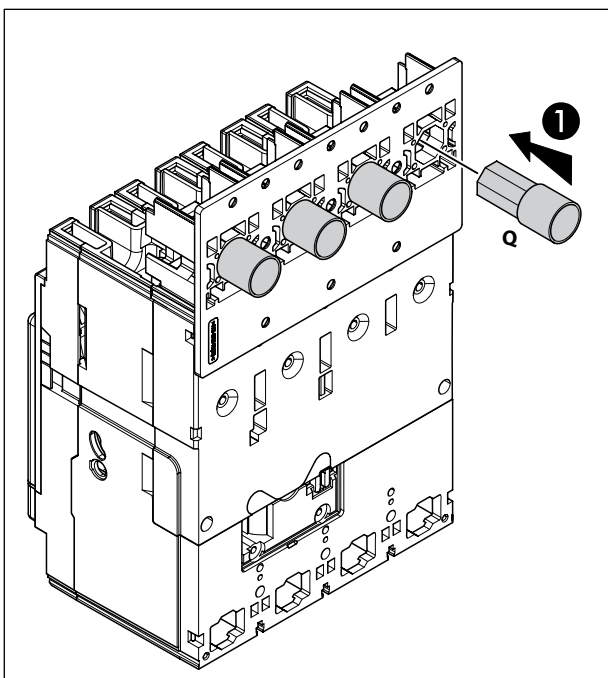
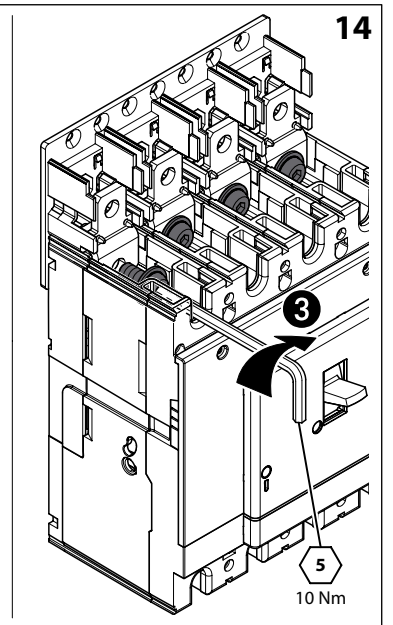
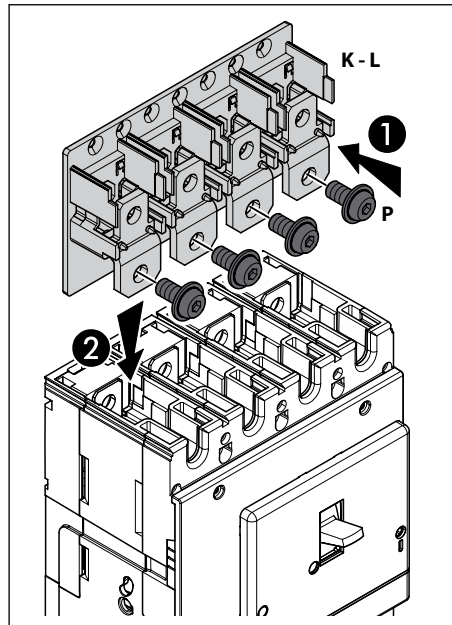
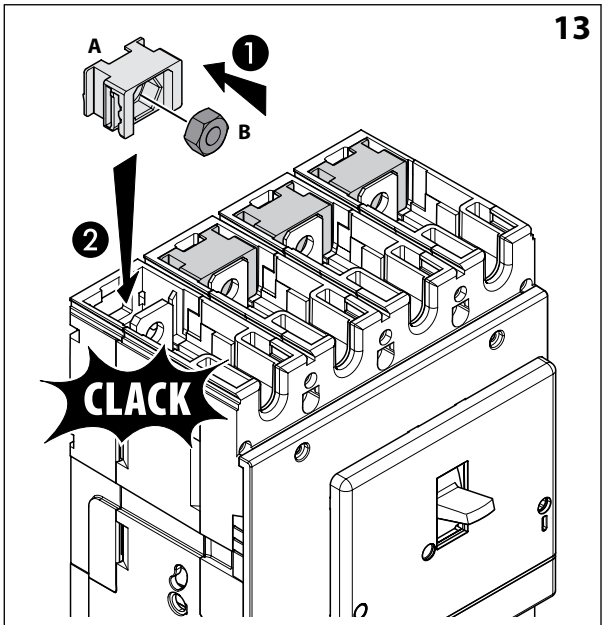
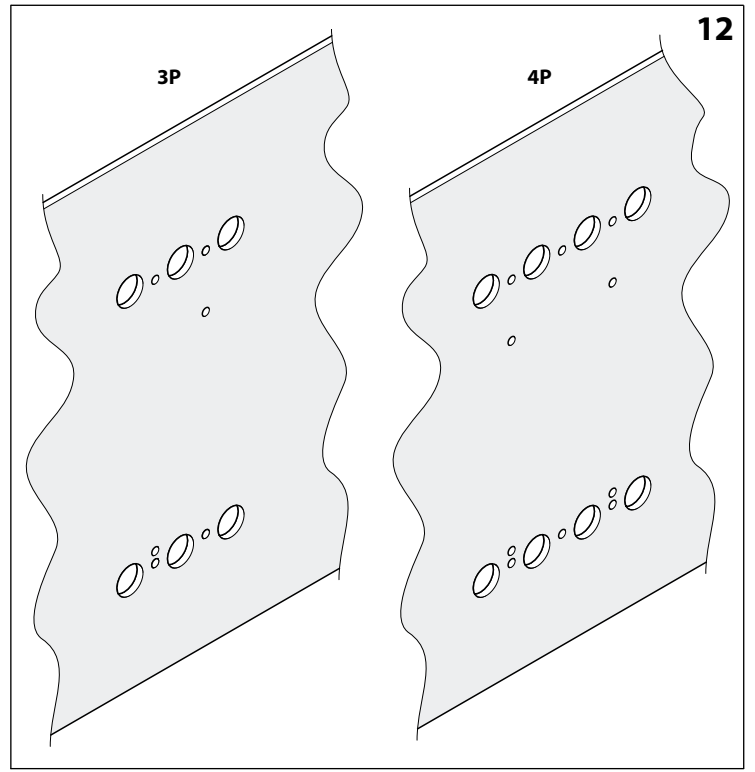
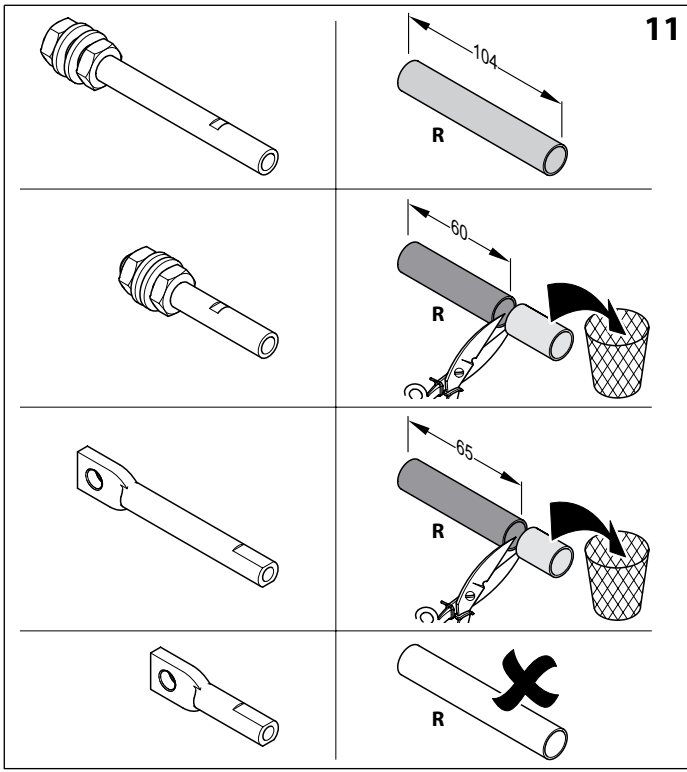

15b

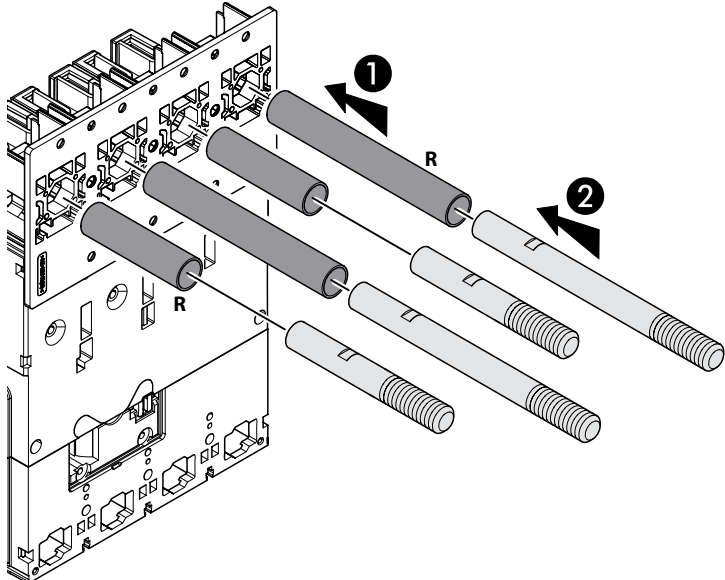

16

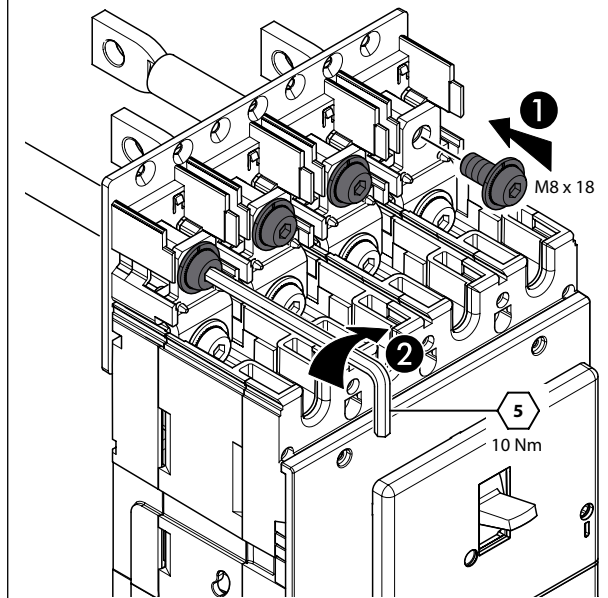

17a

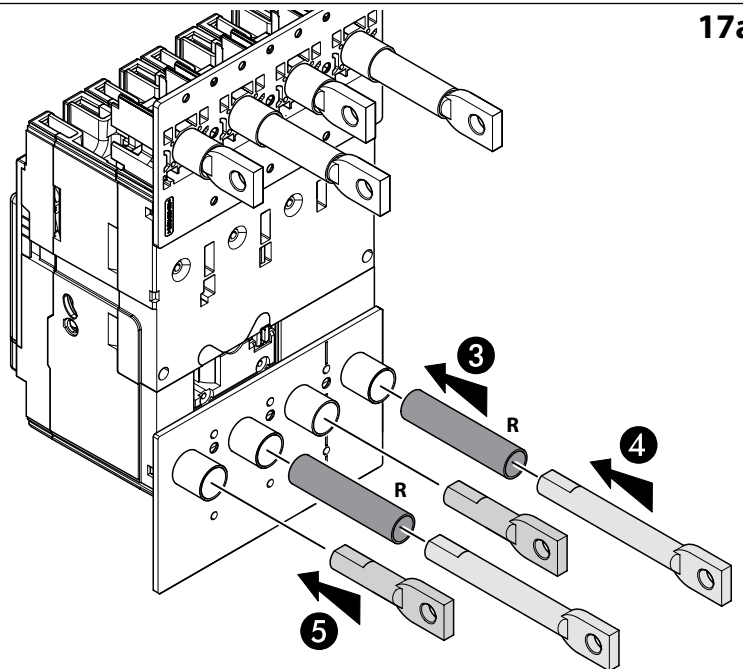
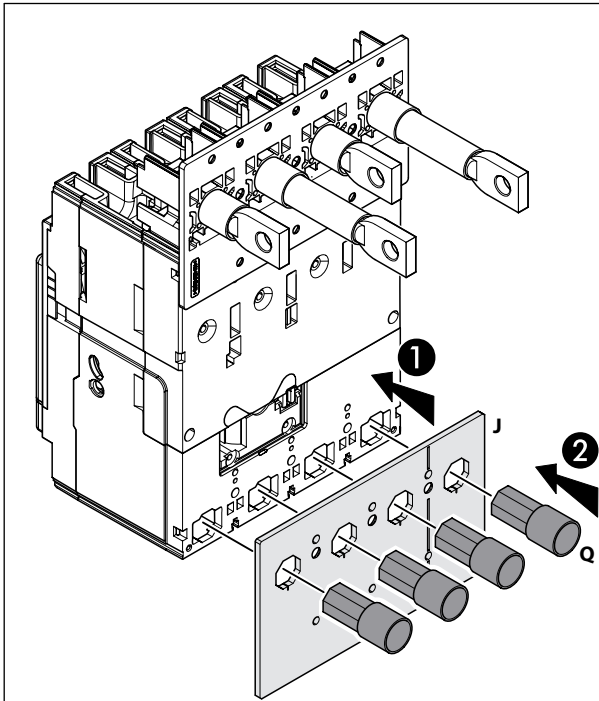

17b

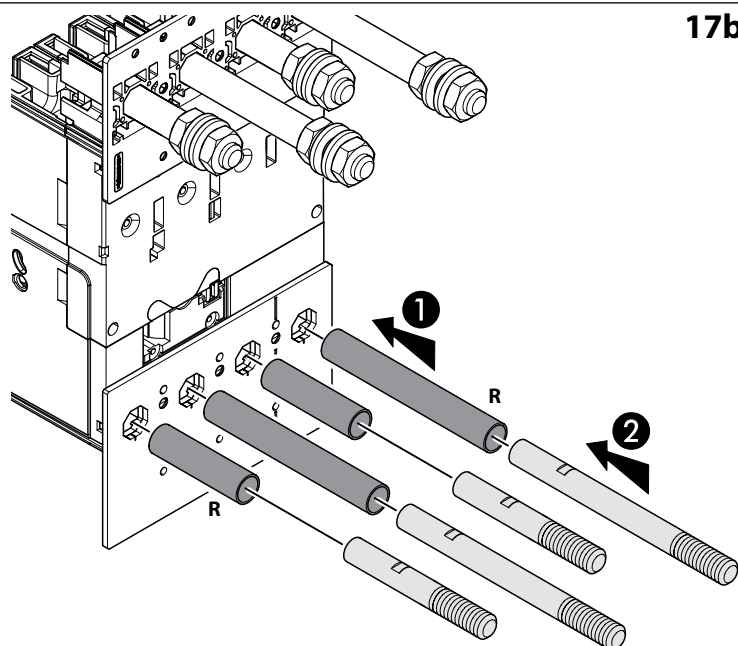

18

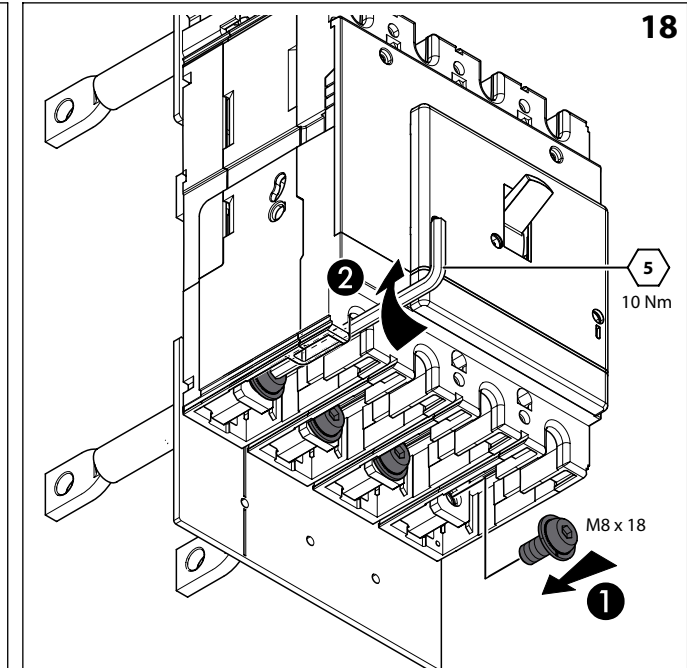

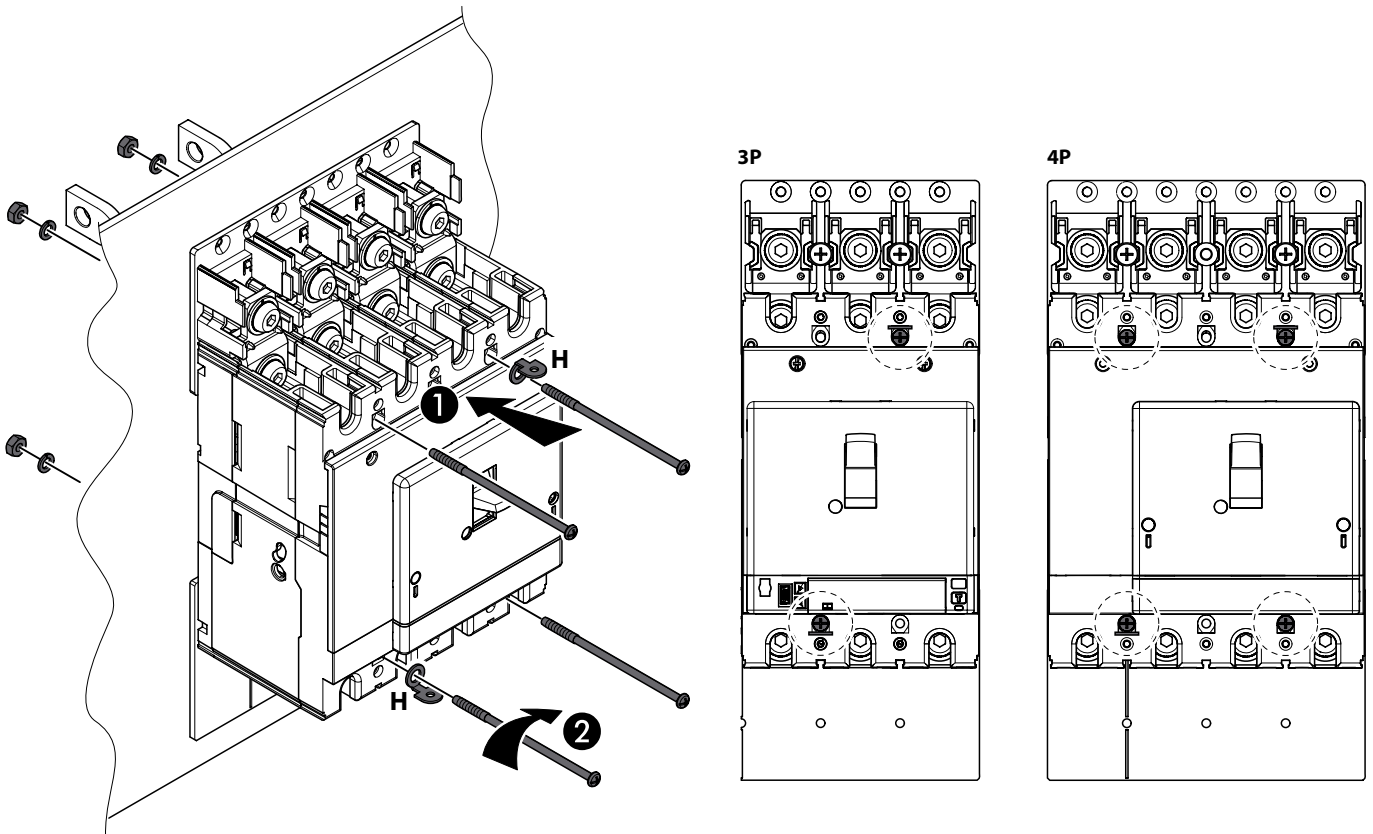
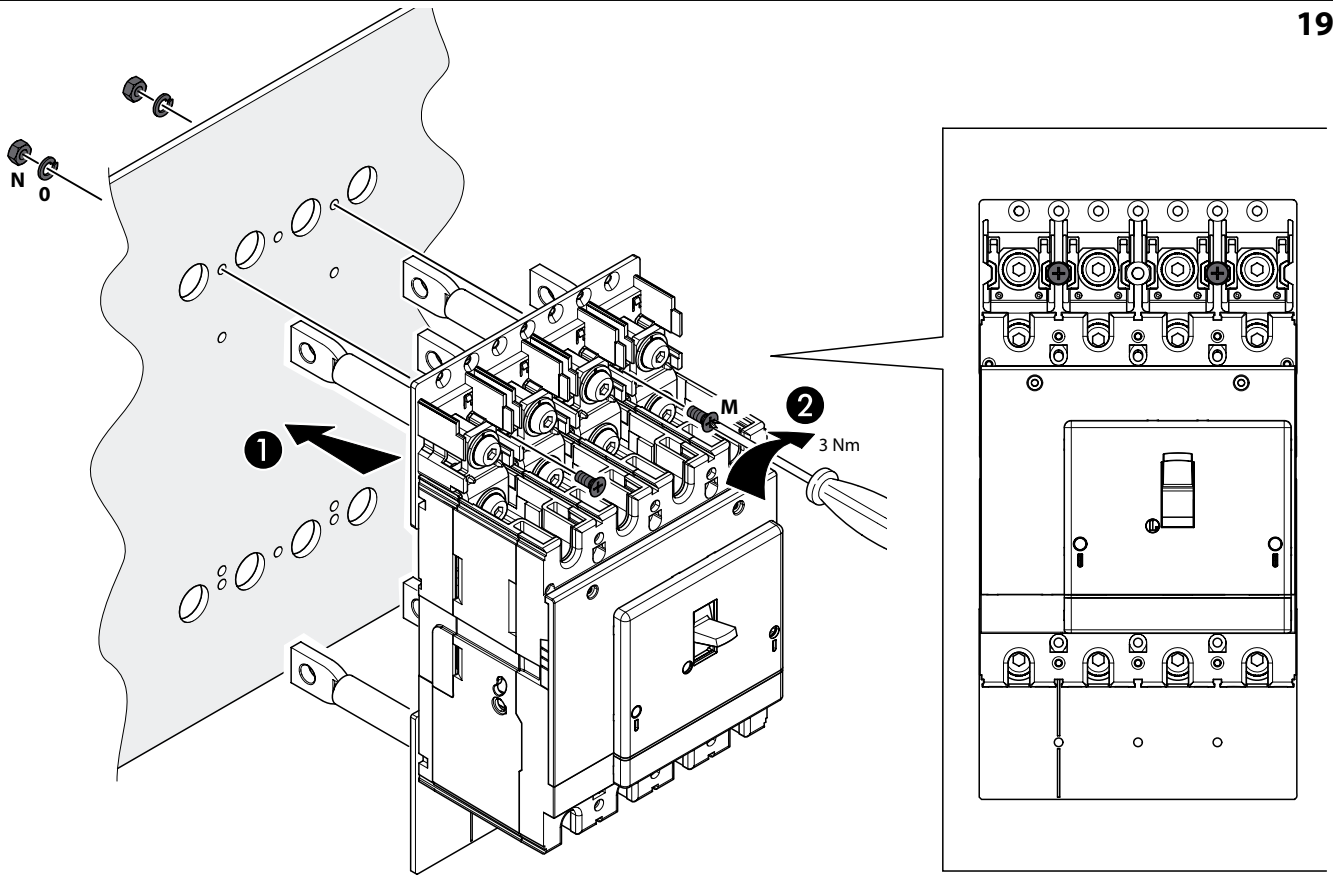

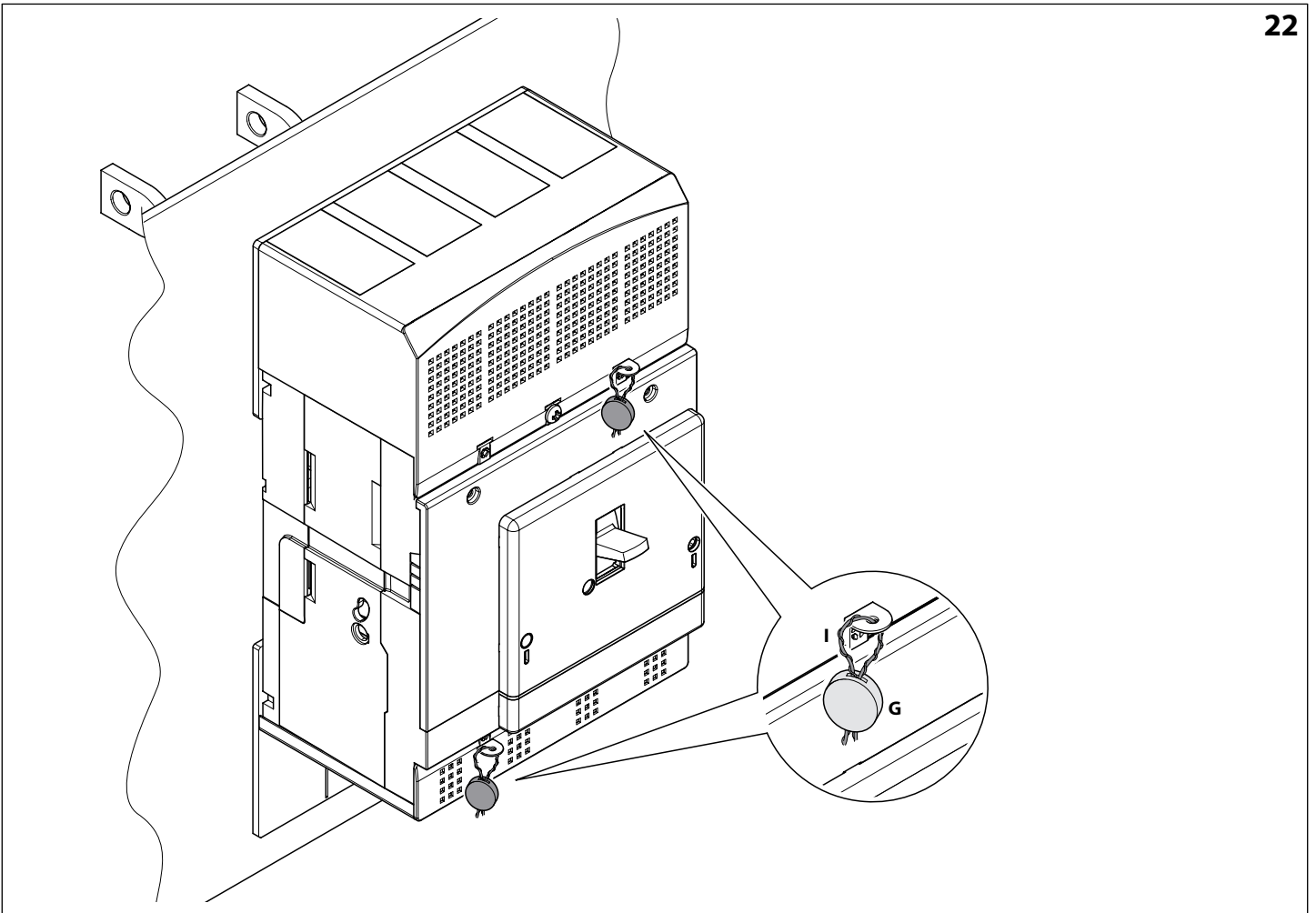
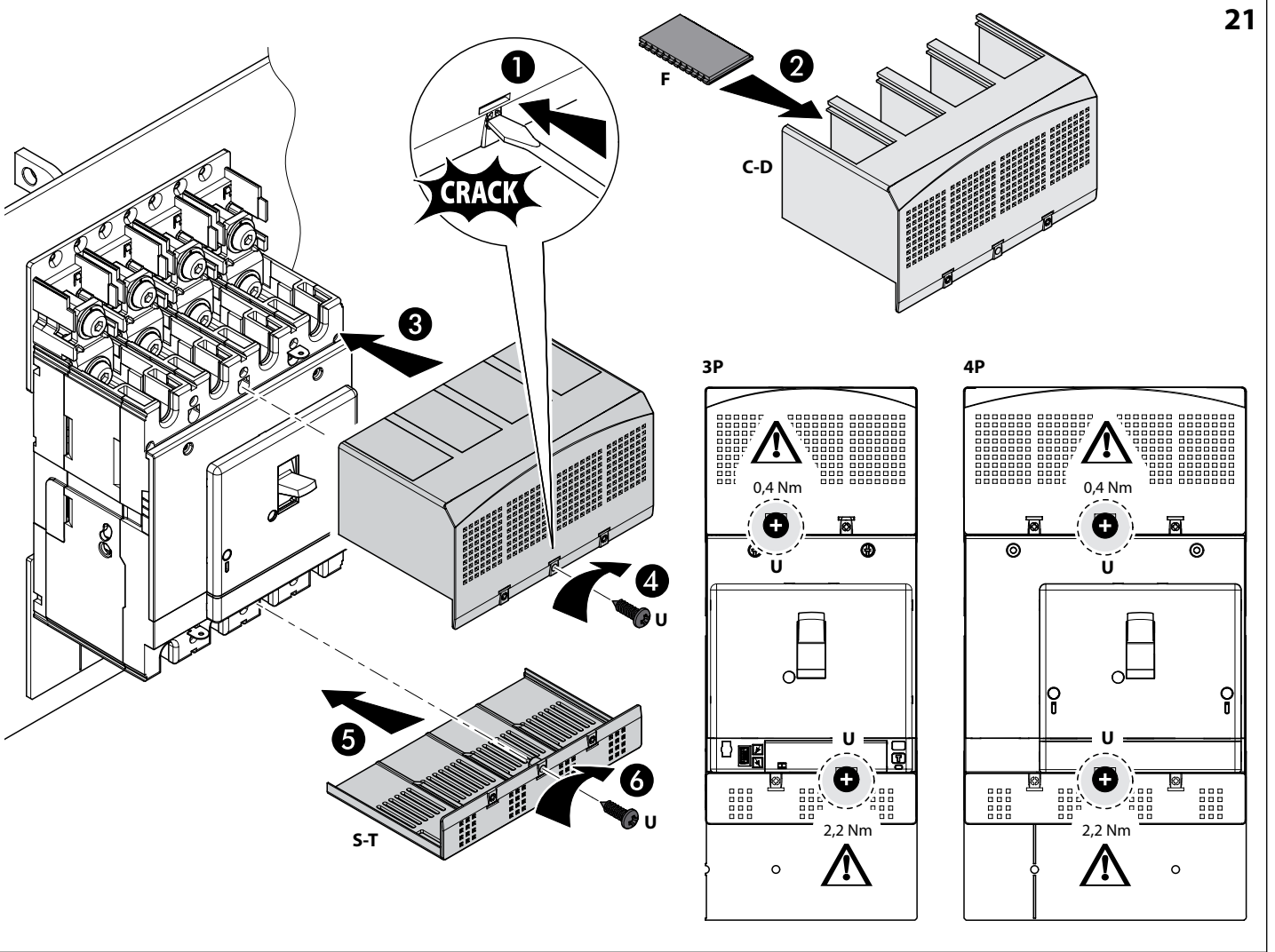

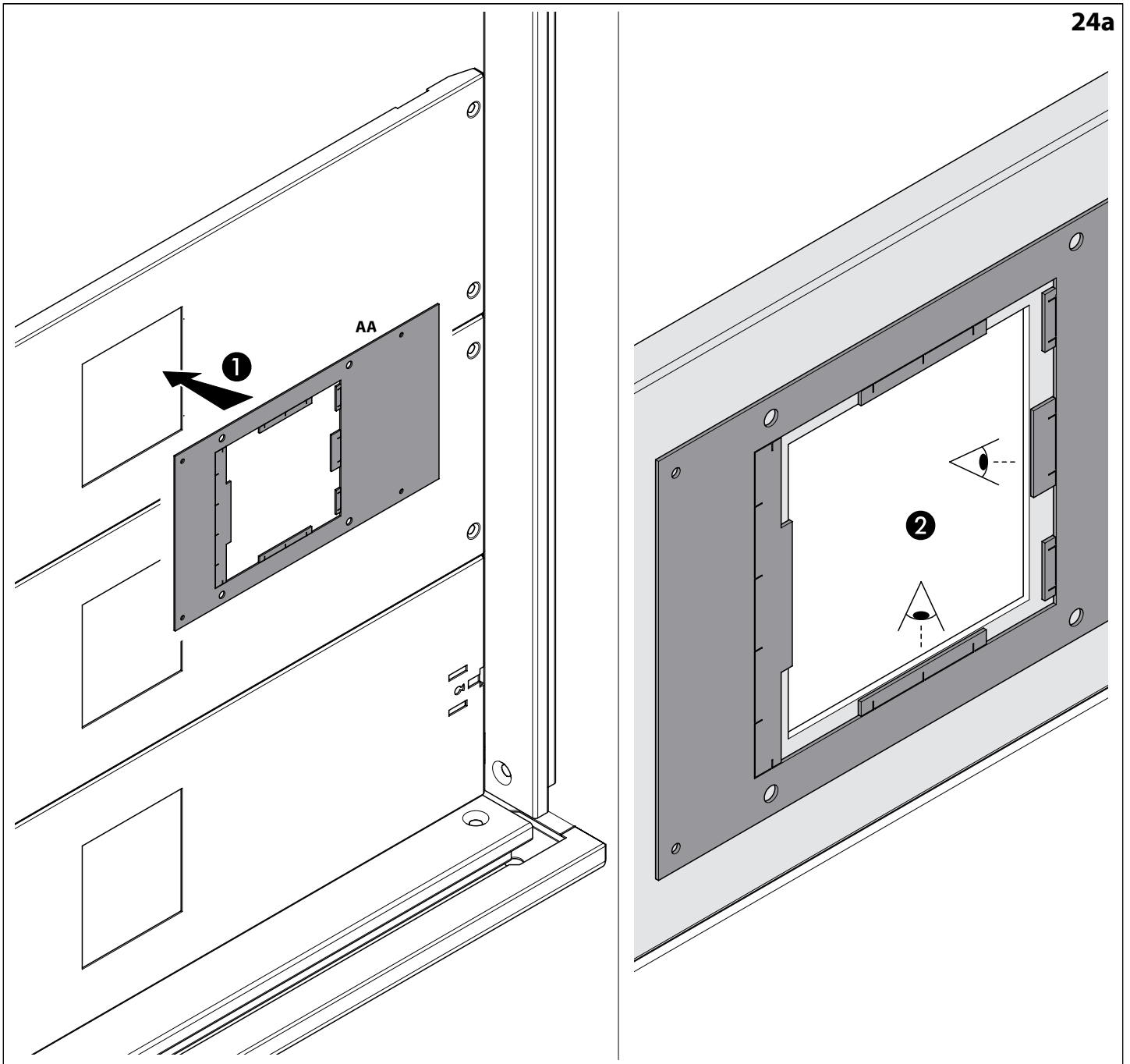
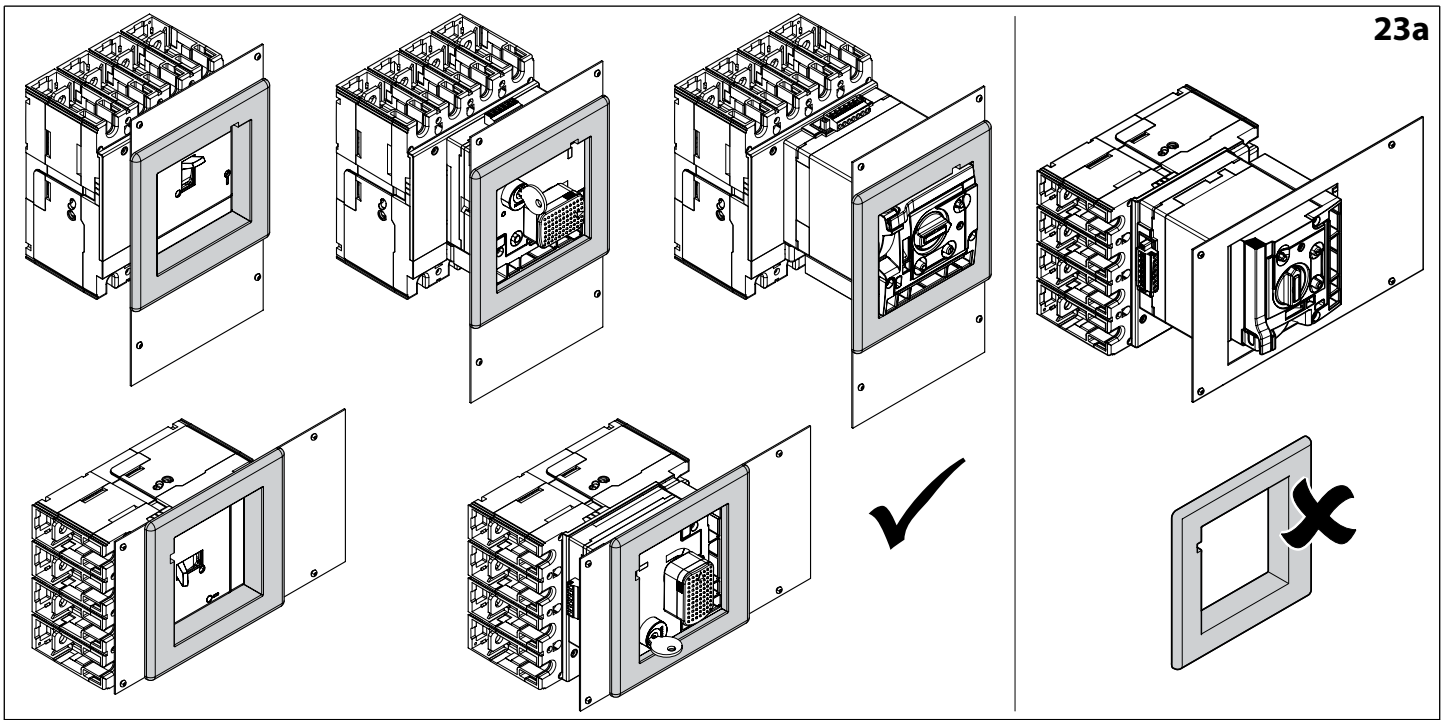

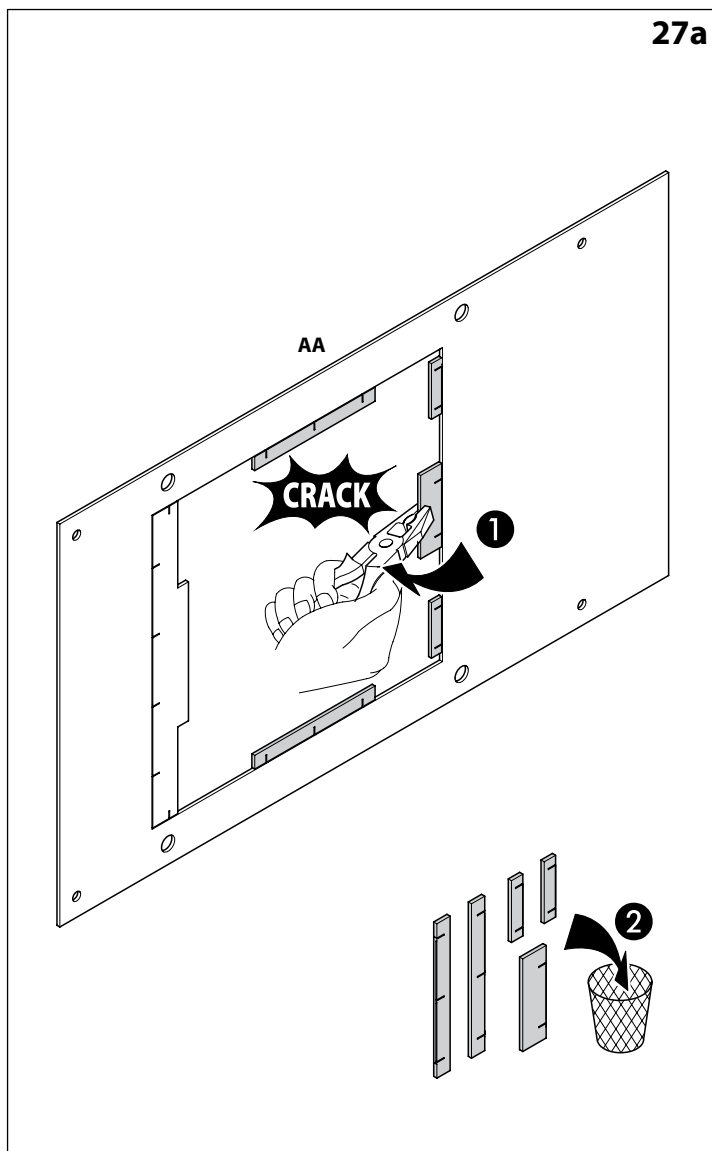
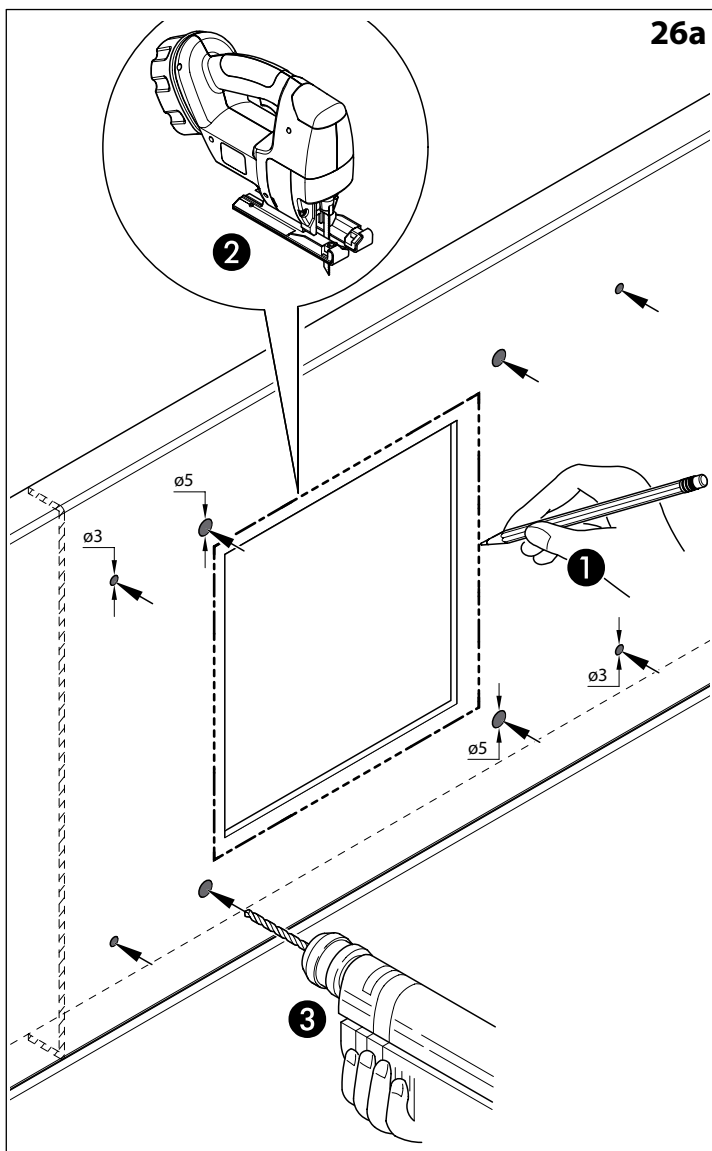
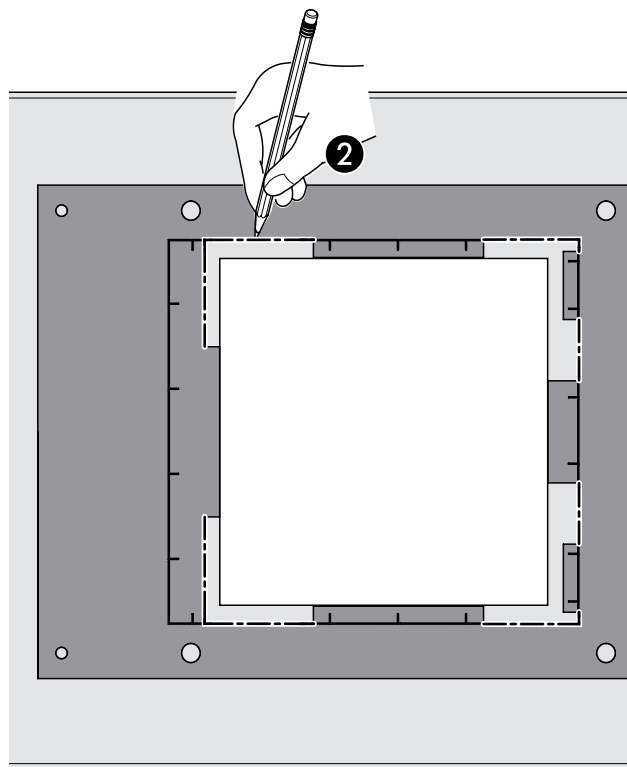
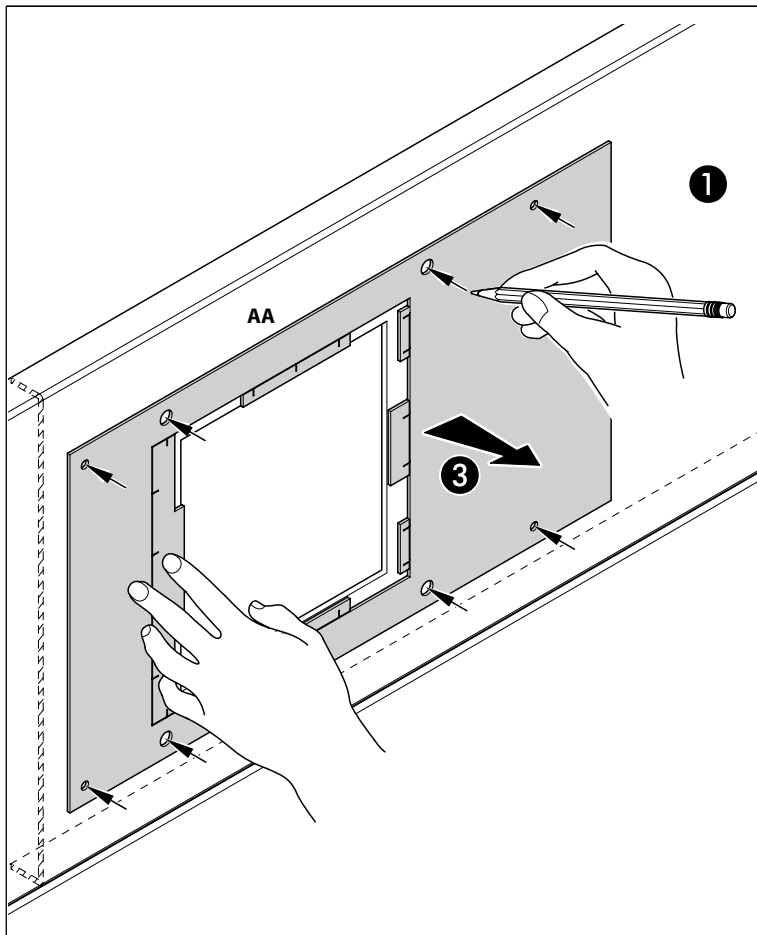

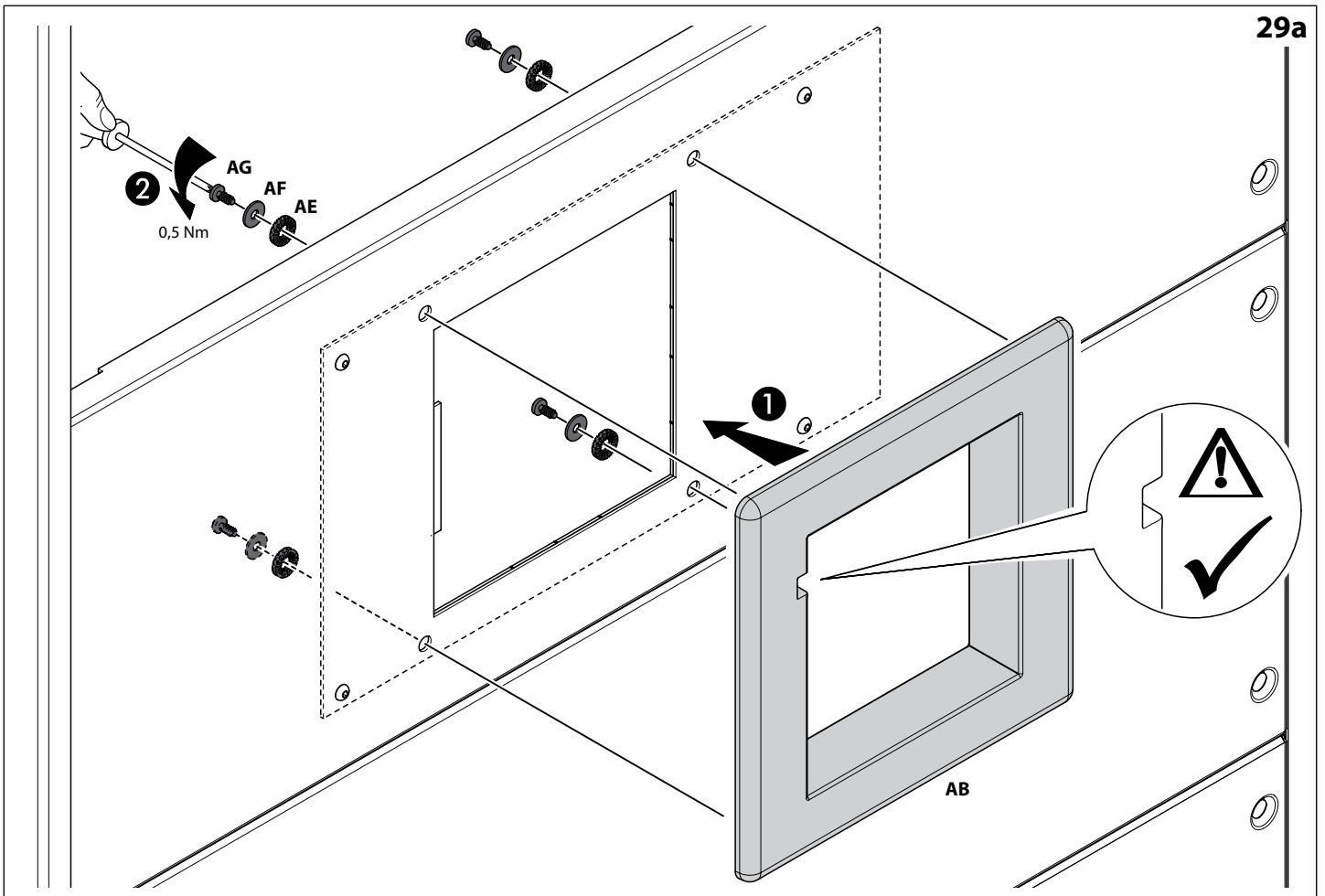
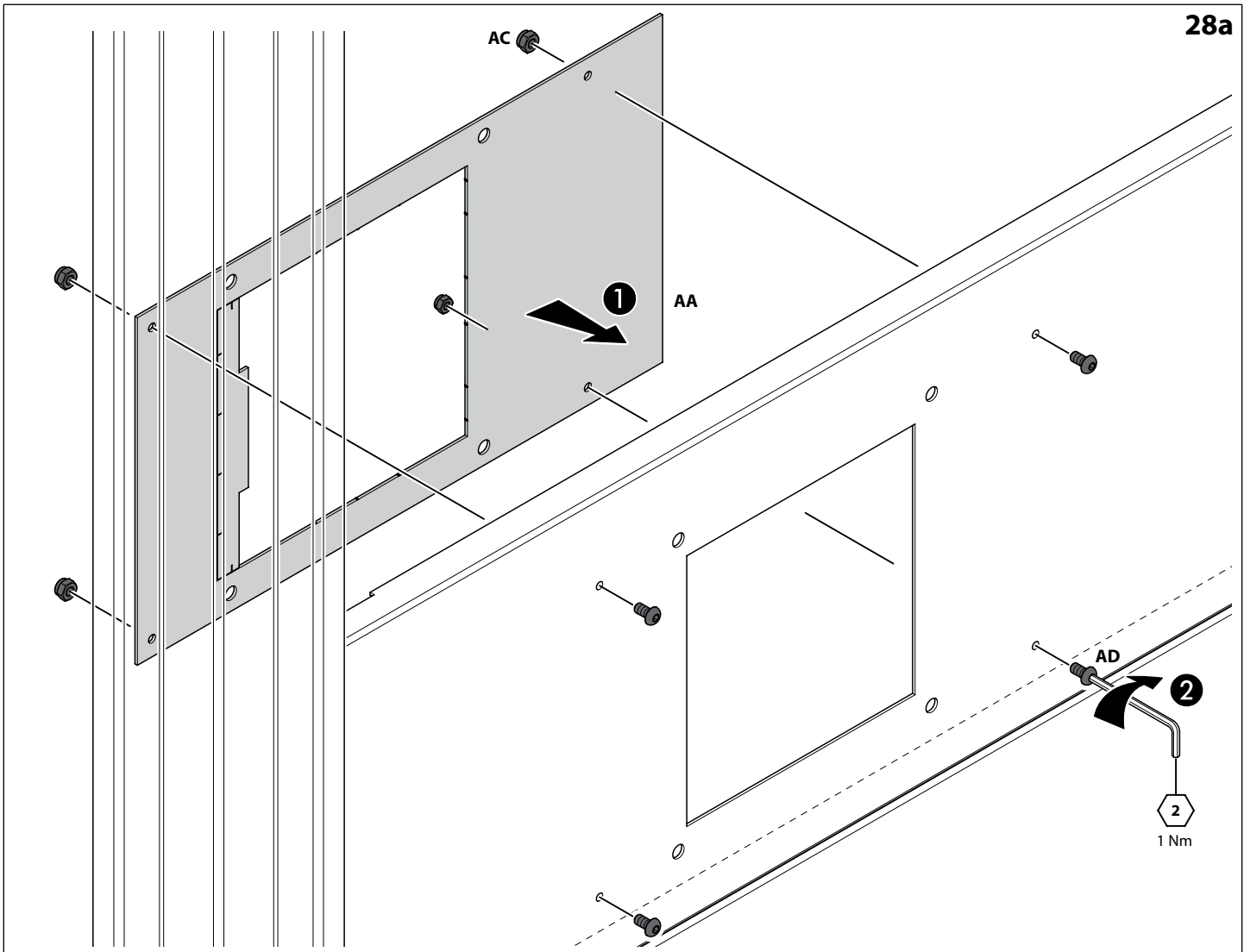



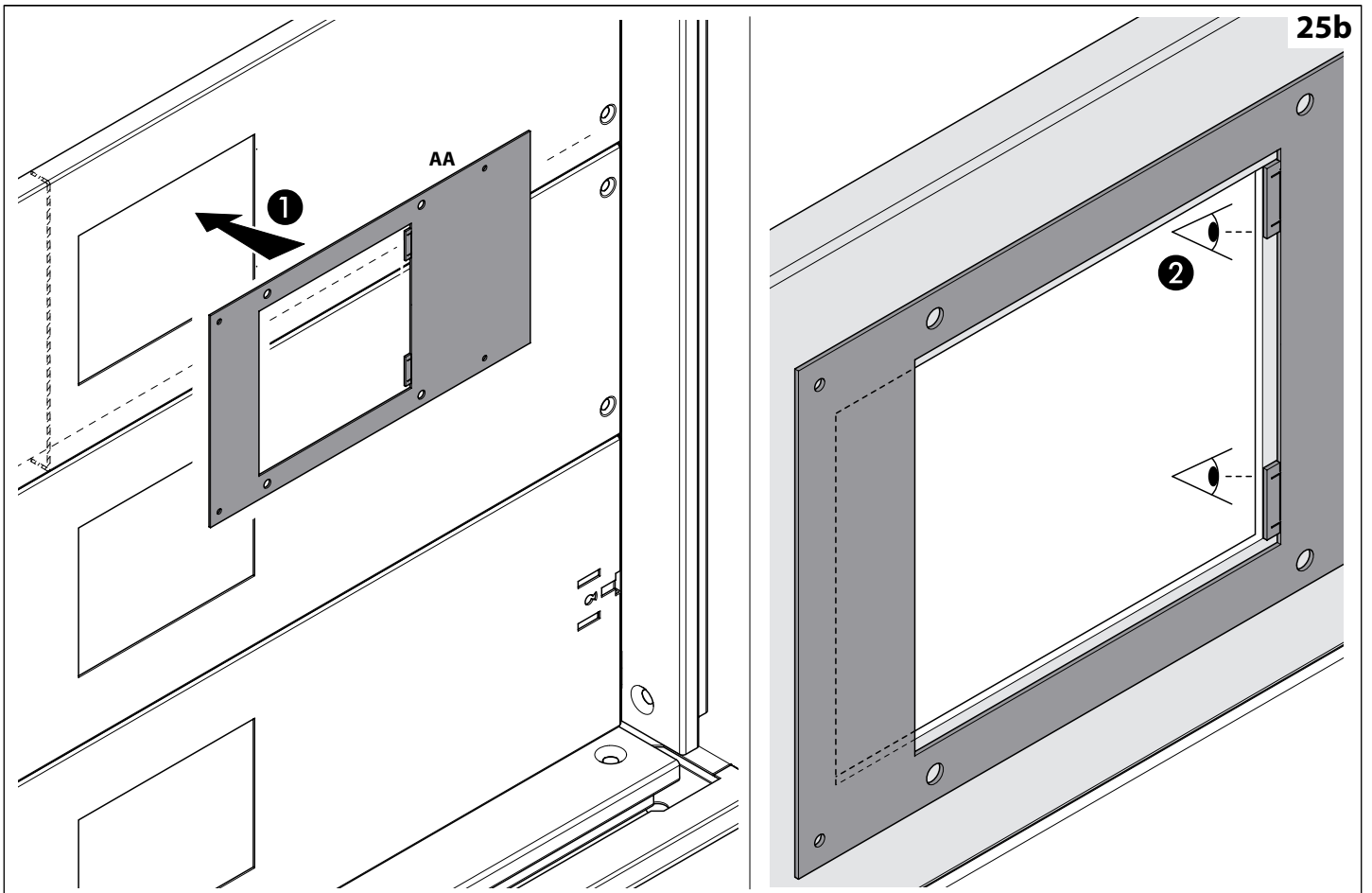
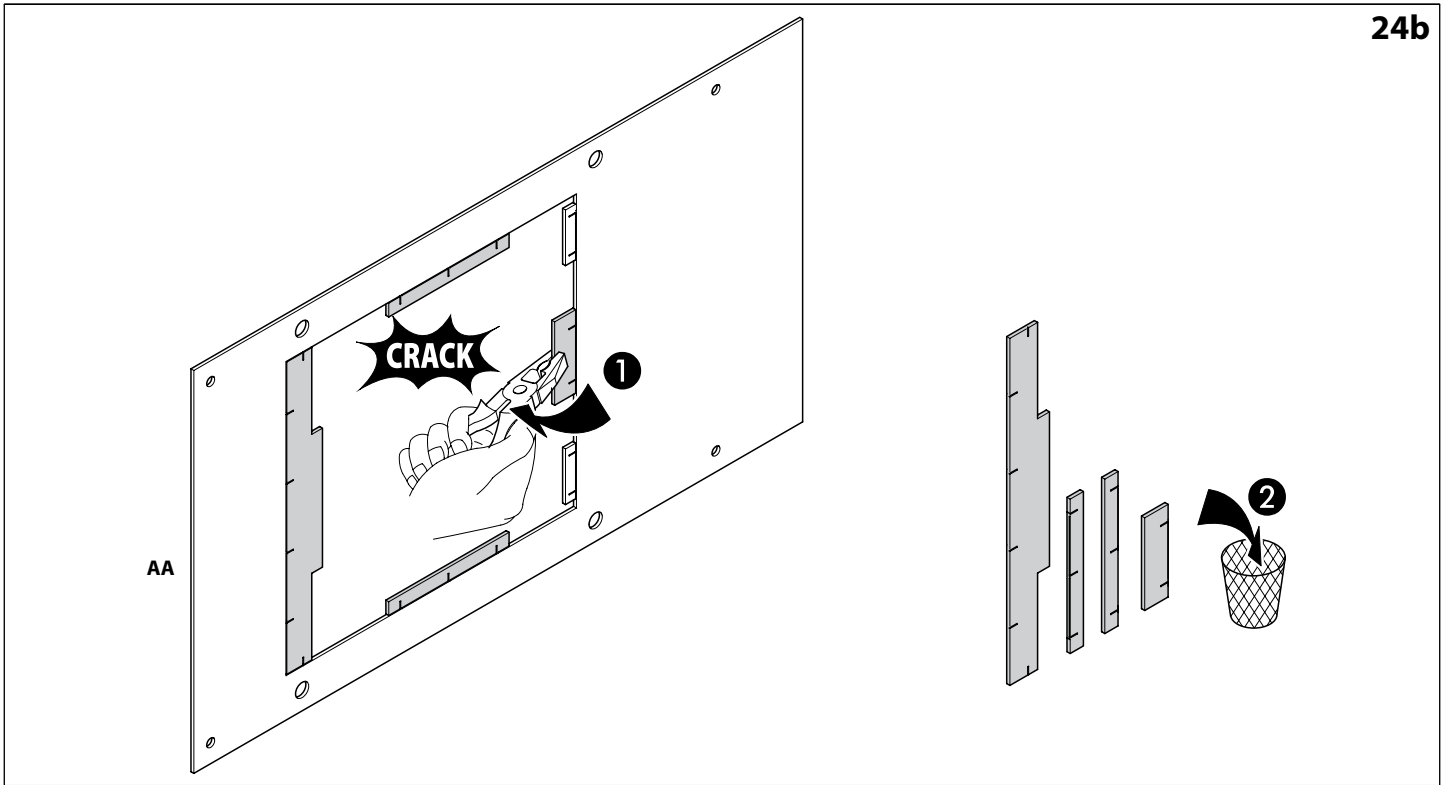
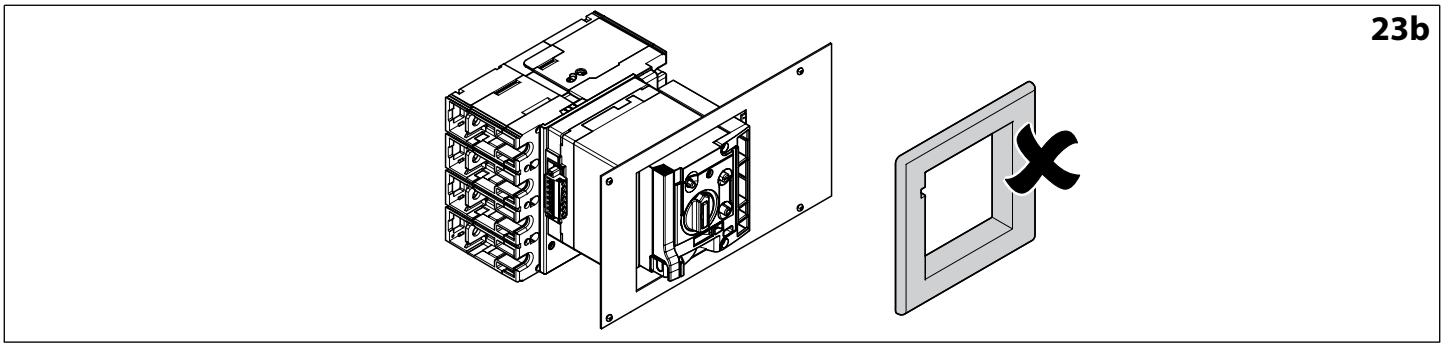

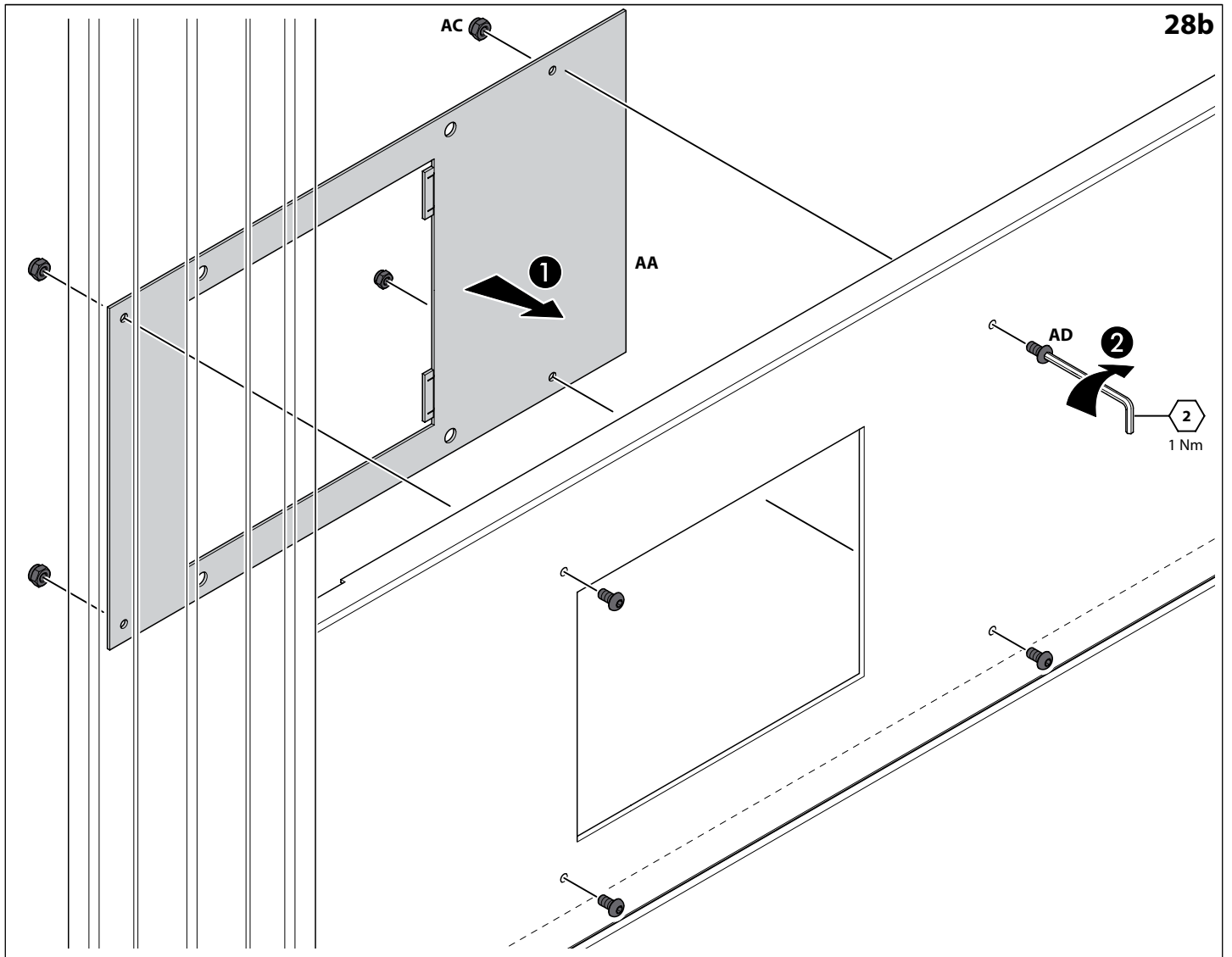
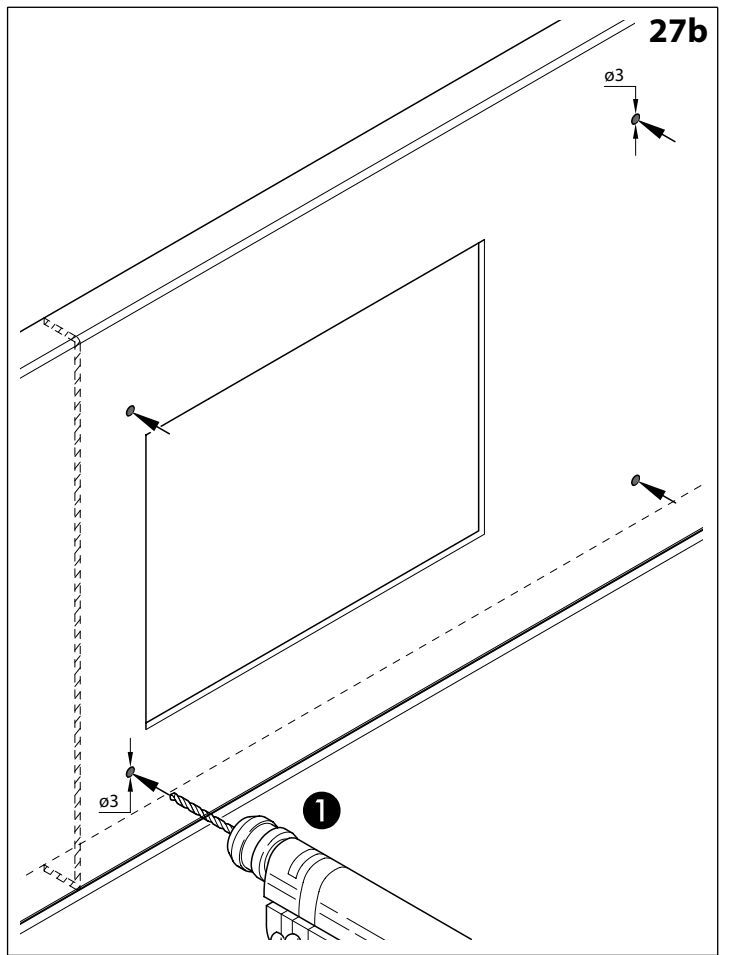
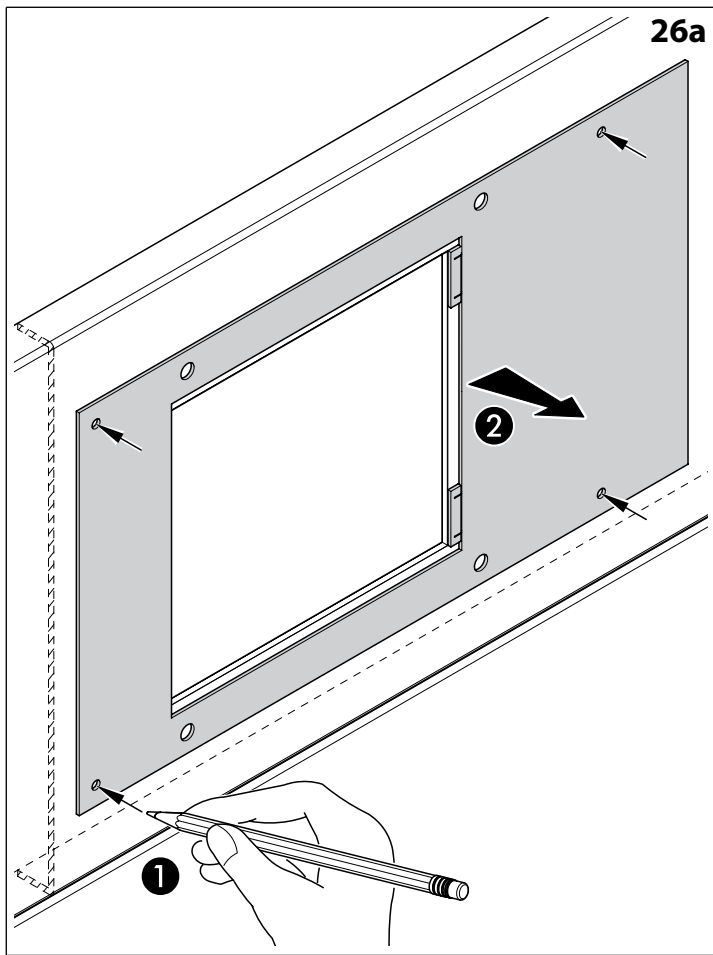

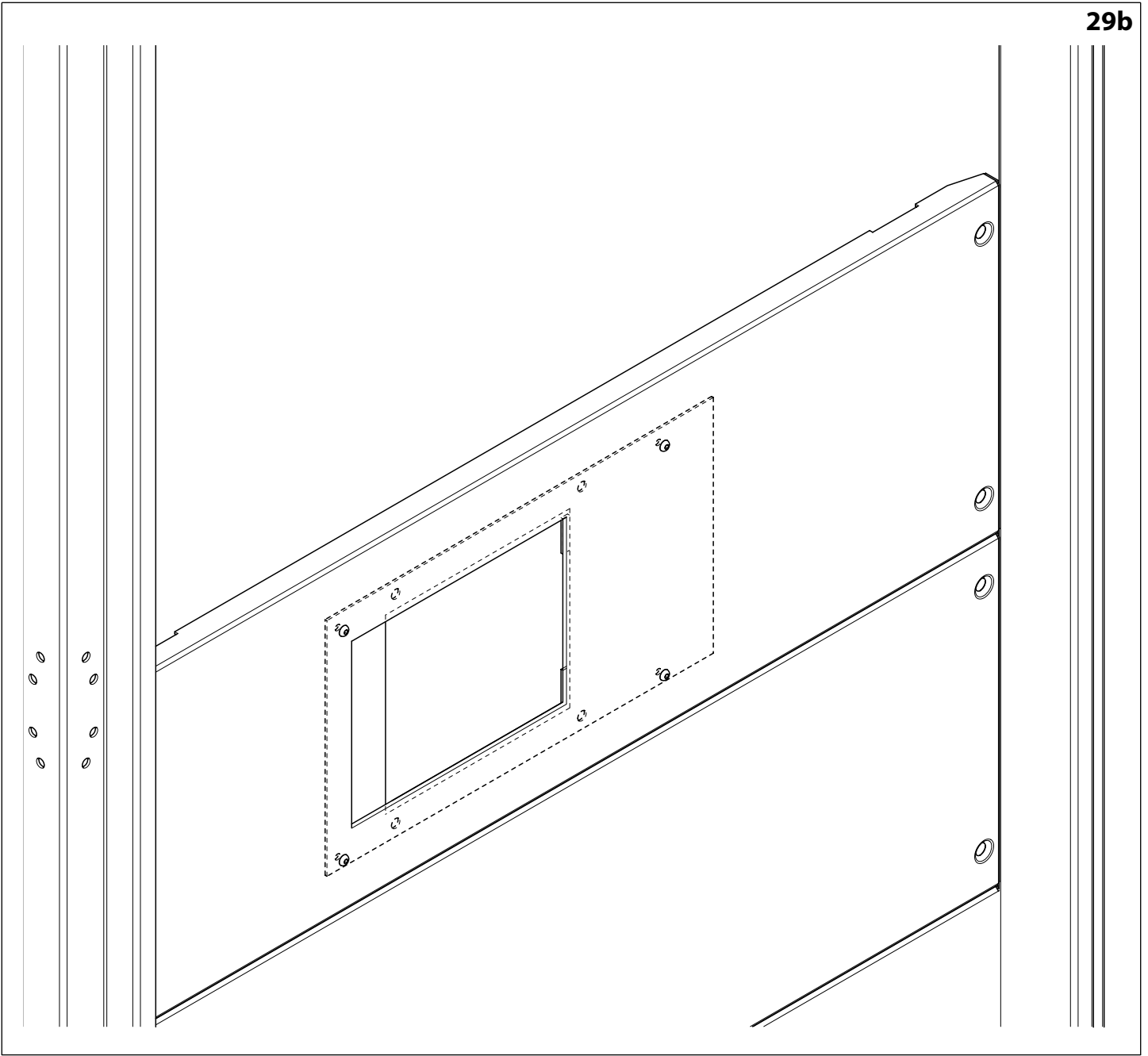



FR BE CA LU CH

### Consignes de sécurité

Ce produit doit être installé conformément aux règles d'installation et de préférence par un électricien qualifié. Une installation et une utilisation incorrectes peuvent entraîner des risques de choc électrique ou d'incendie. Avant d'effectuer l'installation, lire la notice, tenir compte du lieu de montage spécifique au produit. Ne pas ouvrir, démonter, altérer ou modifier l'appareil sauf mention particulière indiquée dans la notice. Tous les produits Legrand doivent exclusivement être ouverts et réparés par du personnel formé et habilité par Legrand. Toute ouverture ou réparation non autorisée annule l'intégralité des responsabilités, droits à remplacement et garanties. Utiliser exclusivement les accessoires de la marque Legrand.



GB CA IN IE US

### Safety instructions

This product should be installed in compliance with installation rules, preferably by a qualified electrician. Incorrect installation and use can lead to risk of electric shock or fire. Before carrying out the installation, read the instructions and take account of the product's specific mounting location. Do not open up, dismantle, alter or modify the device except where specifically required to do so by the instructions. All Legrand products must be opened and repaired exclusively by personnel trained and approved by Legrand. Any unauthorised opening or repair completely cancels all liabilities and the rights to replacement and guarantees. Use only Legrand brand accessories.



IT CH

### Istruzioni di sicurezza

Questo prodotto deve essere installato in conformità con le regole d'installazione e di preferenza da un elettricista qualificato. L'eventuale installazione e utilizzo improprio dello stesso possono comportare rischi di shock elettrico o incendio. Prima di procedere all'installazione, leggere attentamente le istruzioni associate e individuare un luogo di montaggio idoneo in funzione del prodotto. Non aprire, smontare, alterare o modificare l'apparecchio eccetto speciale menzione indicata nel manuale. Tutti i prodotti Legrand devono essere esclusivamente aperti e riparati da personale adeguatamente formato e autorizzato da Legrand. Qualsiasi apertura o riparazione non autorizzata comporta l'esclusione di eventuali responsabilità, diritti alla sostituzione e garanzie. Utilizzare esclusivamente accessori a marchio Legrand.



ES CL CO CR MX PE US VE

### Consignes de seguridad

Este producto debe instalarse conforme a las normas de instalación y preferiblemente por un electricista cualificado. Una instalación y una utilización incorrectas pueden entrañar riesgos de choque eléctrico o de incendio. Antes de efectuar la instalación, leer las instrucciones, tener en cuenta el lugar de montaje específico del producto. No abrir, desmontar, alterar o modificar el aparato salvo que esto se indique específicamente en las instrucciones. Todos los productos Legrand deben ser abiertos y reparados exclusivamente por personal formado y habilitado por Legrand. Cualquier apertura o reparación no autorizada anula la totalidad de las responsabilidades, derechos a sustitución y garantías. Utilizar exclusivamente los accesorios de la marca Legrand.



PT

### Instruções de segurança

Este produto deve ser instalado de acordo com as regras de instalação e de preferência por um electricista qualificado. A instalação e o uso incorrectos podem provocar riscos de choque eléctrico ou de incêndio. Antes de efectuar a instalação, ler as instruções e ter em conta a localização adequada para a montagem do produto. Não abrir, desmontar, alterar ou modificar o aparelho salvo especificação em contrário nas instruções do produto. Todos os produtos Legrand só devem ser abertos e reparados exclusivamente por pessoal formado e autorizado pela Legrand. Qualquer abertura ou reparação não autorizada cancela todas as responsabilidades, direitos de substituição e garantias. Utilizar exclusivamente os acessórios da marca Legrand.



RU

### Меры предосторожности

Установка данного изделия должна выполняться в соответствии с правилами монтажа и предпочтительно квалифицированным электриком. Неправильный монтаж или нарушение правил эксплуатации изделия могут привести к возникновению пожара или поражению электрическим током. Перед монтажом необходимо внимательно ознакомиться с данной инструкцией, а также принять во внимание требования к месту установки изделия. Запрещается вскрывать корпус изделия, а также разбирать, выводить из строя или модифицировать изделие, кроме случаев, оговоренных в инструкции. Вскрытие и ремонт изделий марки Legrand могут выполняться только специалистами, обученными и допущенными к таким работам компанией Legrand. Несанкционированное вскрытие или выполнение ремонтных работ посторонними лицами лишает законной силы любые требования об ответственности, замене или гарантийном обслуживании. При ремонте или гарантийном обслуживании использовать только запасные части марки Legrand.



PL

### Przepisy bezpieczeństwa

Produkt ten powinien być montowany zgodnie z zasadami instalacji, najlepiej przez wykwalifikowanego elektryka. Niepoprawna instalacja lub złe użytkowanie mogą spowodować ryzyko porażenia prądem lub pożaru. Przed przystąpieniem do instalacji, zapoznać się z instrukcją i uwzględnić miejsce montażu urządzenia. Nie otwierać, nie demontować ani nie modyfikować urządzenia, jeśli nie ma na ten temat specjalnej wzmianki w instrukcji. Wszystkie produkty Legrand mogą być otwierane i naprawiane wyłącznie przez pracowników przeszkolonych i upoważnionych przez Legrand. Każde otwarcie lub naprawa dokonane bez odpowiedniego upoważnienia zwalnia Legrand od wszelkiej odpowiedzialności, powoduje utratę prawa do wymiany produktu i wygaśnięcie gwarancji. Używać wyłącznie oryginalnych części marki Legrand.



TR CY

### Güvenlik talimatları

Bu ürün montaj kurallarına uygun olarak ve tercihen yetkili bir elektrikçi tarafından yerleştirilmelidir. Hatalı bir yerleştirme ve kullanım, elektrik çarpmasına veya yangına neden olabilir. Yerleştirmeden önce, talimatları okuyun ve ürüne özgü montaj yerine dikkat ediniz. Kılavuzda aksi belirtilmediği sürece cihazı açmayın, sökmeyin veya üzerinde değişiklik yapmayın. Tüm Legrand ürünlerinin yalnız Legrand tarafından eğitilmiş ve yetkilendirilmiş personel tarafından açılması ve tamir edilmesi gerekir. İzin verilmeyen herhangi bir açılma veya tamir, tüm sorumlulukları, değiştirme haklarını ve garantileri iptal eder. Yalnızca Legrand marka aksesuarları kullanın.



### 安全说明

该产品应由拥有电工资格的人进行安装。错误的安装和使用会导致发生触电或火灾等危险。安装前，请仔细阅读安装说明并且考虑产品特殊的安装位置。除安装说明上特殊要求外，不要随意拆开、拆除以及改动该装置。所有罗格朗的产品都只能被罗格朗培训并认可的人员拆开和维系。任何未经授权拆开或维修将被完全取消更换和保证的权利。

### إرشادات الأمان

يجب تركيب هذا المنتج طبقاً لقواعد التركيب ويفضل أن يقوم بالتركيب كهربائي مؤهل. فقد يؤدي التركيب الخاطئ و/أو الاستخدام الخاطئ إلى مخاطر التعرض لصدمة كهربائية أو نشوب حريق. اقرأ النشرة قبل التركيب، وأقرأ مكاناً لتركيب المنتج خلاصاً به. لا تفتح أو تترك أو تحوّل أو تعالج المنتج ما لم يُشر إلى ذلك بشكل محدد في النشرة. فكل منتجات Legrand يجب فتحها وإصلاحها حصراً من قبل فنيين مبرّين ومؤهلين لدى Legrand. وكل فتح أو إصلاح غير مسموح به يُبطل المسؤوليات وحقوق الاستبدال والضمانات. لا تستخدم سوى إكسسوارات من ماركة Legrand حصراً.