

**Sommaire/Content**

Accessoires Accessories.....	2	Lovage câbles arrière Rear cable coiling.....	5
Montage management arrière sur panneau 2U et 4U Installing the rear management system on 2U and 4U panel.....	3	Mise à la terre Earthing.....	6
Montage panneau Installing a fibre optic cassette.....	4	Démontage cassette par l'avant Removing a cassette from the front.....	6
Montage cassette fibre optique Installing the cassette.....	4	Démontage cassette par l'arrière Removing a cassette from the back.....	6
Montage et démontage obturateur cassette slim Installing and removing the slim cassette blanking plate.....	4	Remontage cassette par l'arrière Reinstalling a cassette from the back.....	7
Repérage Identification.....	5	Démontage management avant Removing the front management system.....	7
Raccordement cassette préconnectée Connecting a pre-terminated cassette.....	5	Autres configurations Other configurations.....	7-8
		Consignes de sécurité Safety instructions.....	8

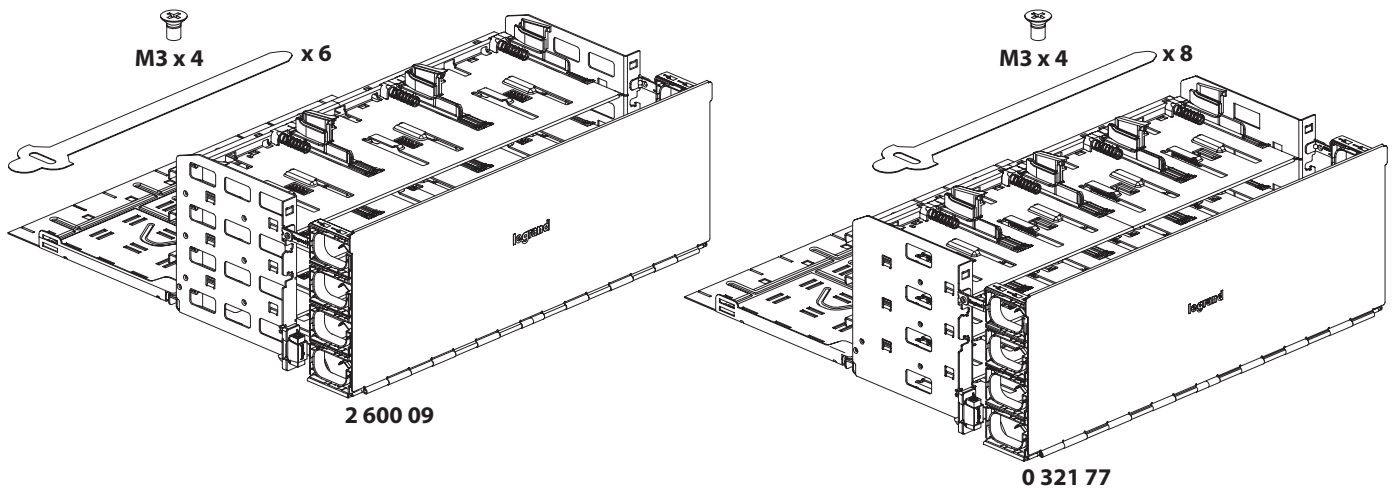
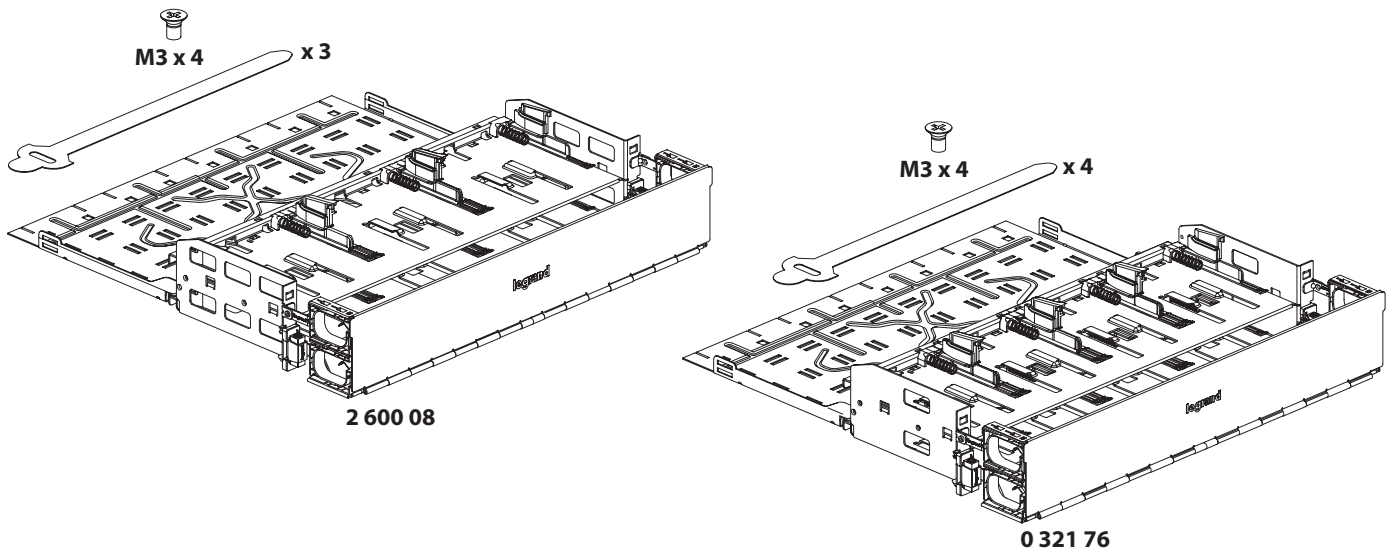
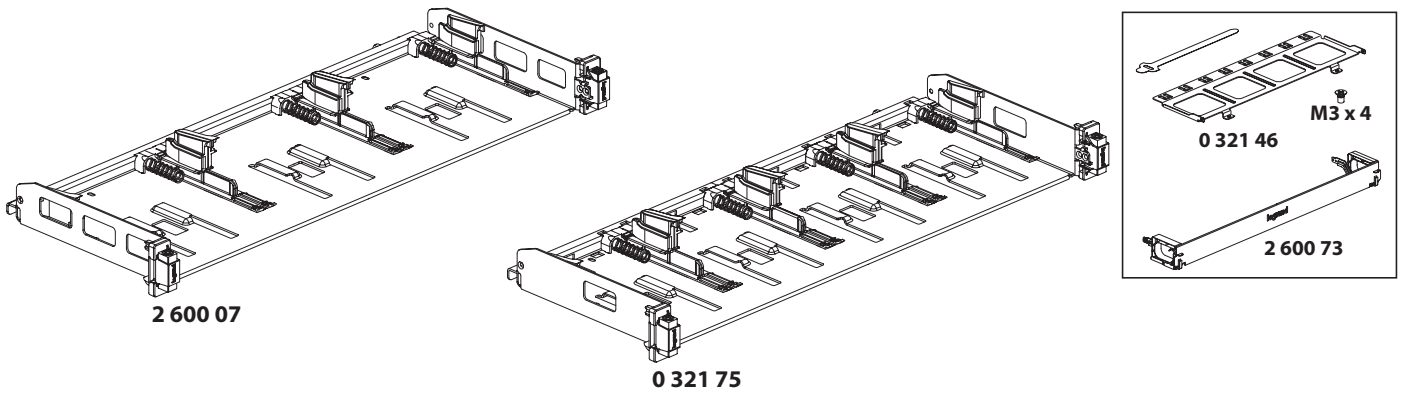

• Compatibilité  
• Compatibility

• Kompatibilität  
• Compatibilidad

• Uyumluluk  
• التوافق

• Совместимость  
• Compatibilità

• 兼容性

Panels			Universal polarity					A/C polarity					HD support for cassettes	Accessoires			
			OS2/UPC	OS2/APC	OM4 Aqua	OM4 Violet	OM5	OS2/UPC	OS2/APC	OM4 Aqua	OM4 Violet	OM5					
Base 12	032175	Slim cassette	12F MTP-LC		260021	-	260022	260023	260024	On-demand	-	On-demand	On-demand	On-demand	032138	032139	033685
			2x 12F MTP-SN		260025	-	260026	-	260027	On-demand	-	On-demand	-	On-demand			
	032176	HD cassette	2x 12F MTP-MDC		On-demand	-	On-demand	-	On-demand	-	-	-	-	260054	-		
	032177		12F MTP-LC		260050	On-demand	260048	-	-	On-demand	On-demand	On-demand	-			-	
		2x 12F MTP-LC		260051	On-demand	260049	-	-	On-demand	On-demand	On-demand	-	-				
		12F MTP-SC		260053	On-demand	260052 *Beige	-	-	On-demand	On-demand	On-demand *Beige	-	-				
Base 16	260007	Slim cassette	16F MTP-LC		260013	-	260014	260015	260016	On-demand	-	On-demand	On-demand	On-demand	260010	260011	260012
			2x 8F MTP-LC		260017	-	260018	260019	260020	On-demand	-	On-demand	On-demand	On-demand			
	260008		4x 8F MTP-SN		260028	-	260029	-	260030	On-demand	-	On-demand	-	On-demand			
			2x 16F MTP-SN		260031	-	260032	-	260033	On-demand	-	On-demand	-	On-demand			
	260009		4x 8F MTP-MDC		On-demand	-	On-demand	-	On-demand	-	-	-	-	-			
			2x 16F MTP-MDC		On-demand	-	On-demand	-	On-demand	-	-	-	-	-			

Panels	Splice cassette	Blocks for splice cassette								Copper cassettes	Connectors for copper cassettes				
		SM Blue	SM APC Green	MM Aqua	MM Violet	MM beige	MM Lime	UTP	FTP		STP				
Base 12	032141 PG 11 x 2	12 fibers	LC		032114	032116	032137	HVBL12	-	032258	033755	Cat5e	033753	033754	-
			SC		032111	-	-	-	032121	-					
		6 fibers	LC		032113	-	032136	-	-	-	033795	Cat6	033763	033764	033765
			SC		032110	032112	-	-	032120	-					
			ST		SM Red cap		MM Black cap			032117			032127	Cat6A	033773

• Accessoires  
• Accessories  
• Zubehör  
• Accesorios  
• Aksesuarlar  
• الملحقات

• Принадлежности  
• Accessori  
• 配件

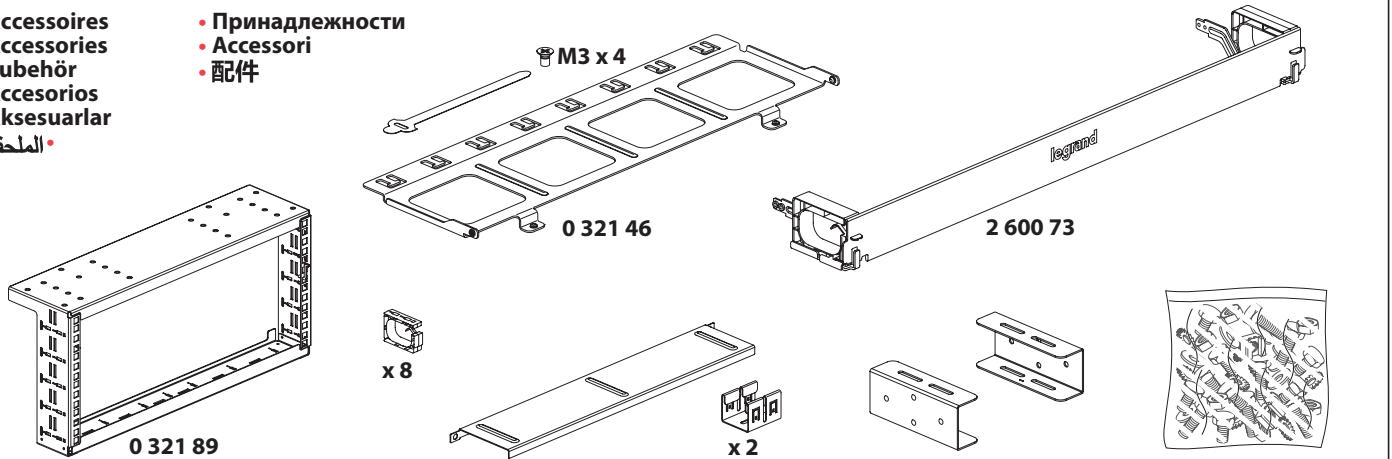

- Montage management arrière sur panneau 2U et 4U
- Installing the rear management system on 2U and 4U panel
- Montage des hinteren Managements an 2U- und 4U-Panel
- Montaje de gestión posterior en paneles 2U y 4U
- 2U ve 4U panel üzerine arka yönetim montajı

- تركيب نظام الإدارة الخلفي في اللوحين 2U و 4U
- Монтаж системы кабельного менеджмента сзади на панели 2U и 4U
- Montaggio gestione posteriore su pannello 2U e 4U
- 在 2U 和 4U 面板上安装后部管理系统

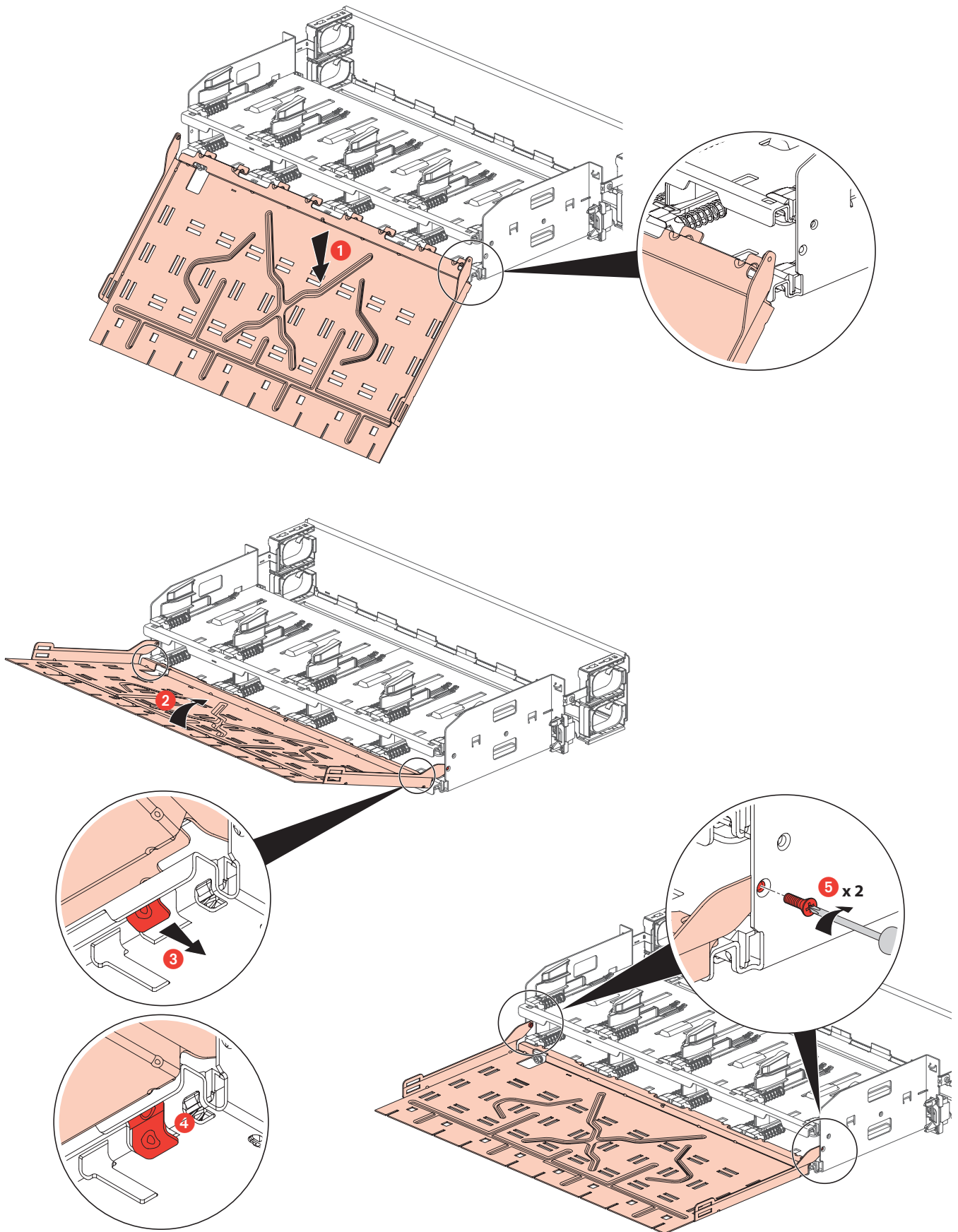

- Montage panneau
- Installing the panel
- Panelmontage

- Montaje del panel
- Panel montaji
- تركيب اللوحة

- Монтаж панели
- Montaggio pannello
- 安装面板

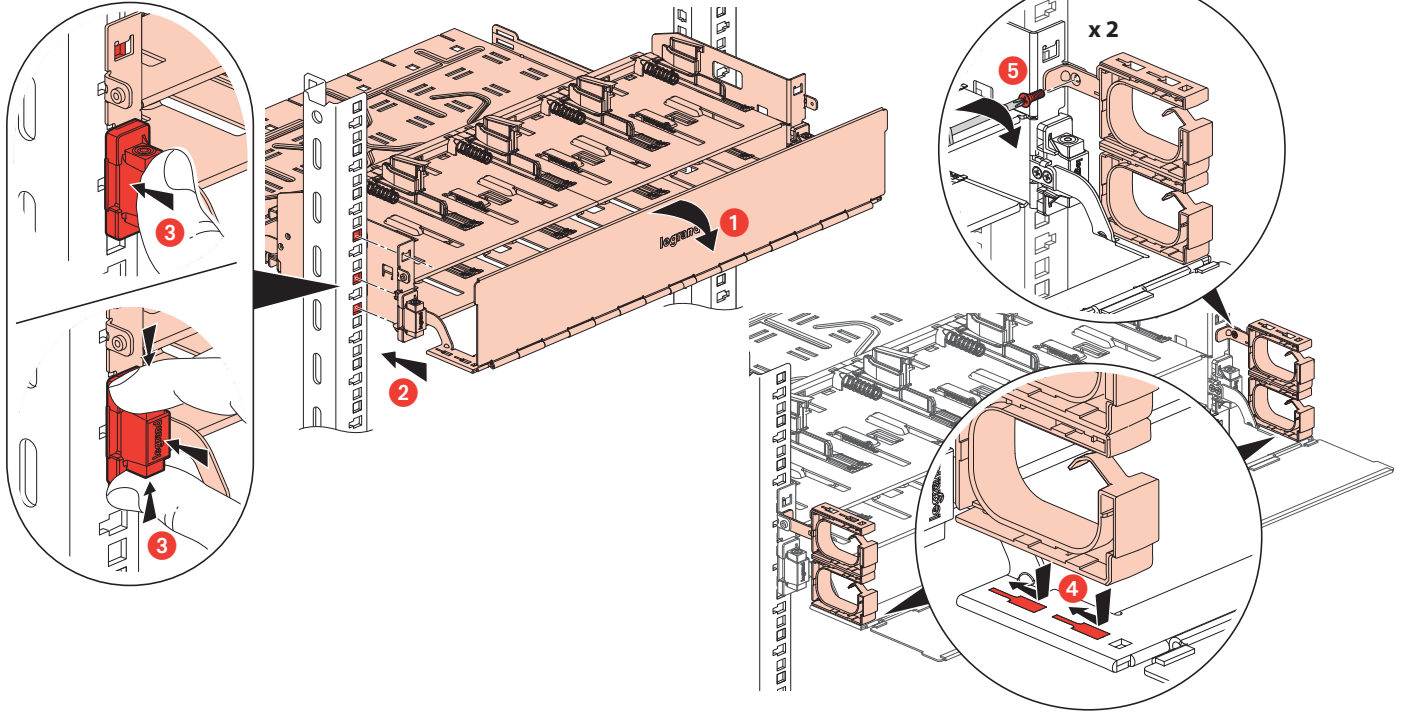

- Montage cassette Fibre optique
- Installing a fibre optic cassette
- Glasfaser-Kassettenmontage

- Montaje de casete de fibra óptica
- Fiber optik kaset montaji
- تركيب علبه ألياف ضوئية

- Монтаж оптической кассеты
- Montaggio cassetta fibra ottica
- 安装光纤盒

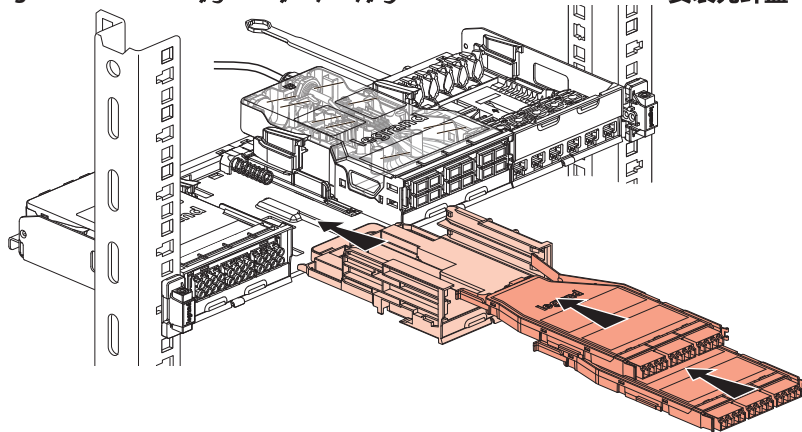

- Montage et démontage obturateur cassette slim
- Installing and removing the slim cassette blanking plate
- Montage und Demontage des Verschlusses der Slim-Kassette
- Montaje y desmontaje del obturador del casete slim
- Slim kaset obtüratörün montaji ve demontaji
- تركيب وفك غطاء الكاسيت النحيف

- Монтаж и демонтаж заслонки кассеты slim
- Montaggio e smontaggio otturatore cassetta slim
- 安装与拆卸 薄型快门盒

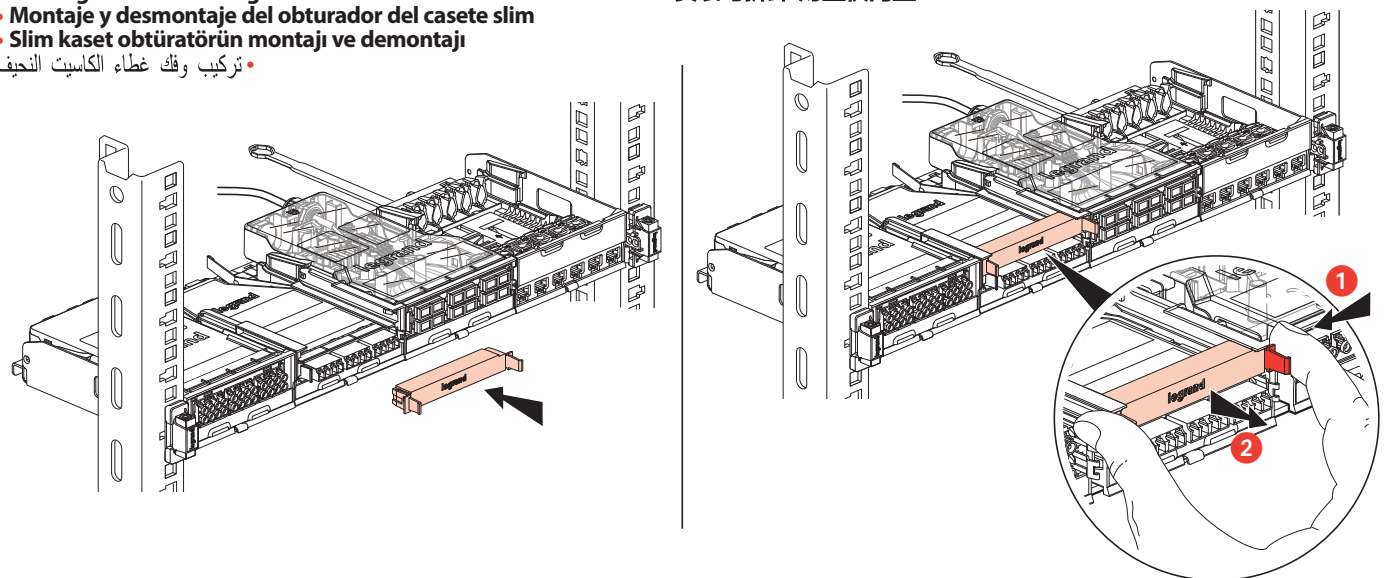

- Repérage
- Identification
- Kennzeichnung

- Señalización
- İşaretleme
- التمييز

- Маркировка
- Marcatura
- 标识

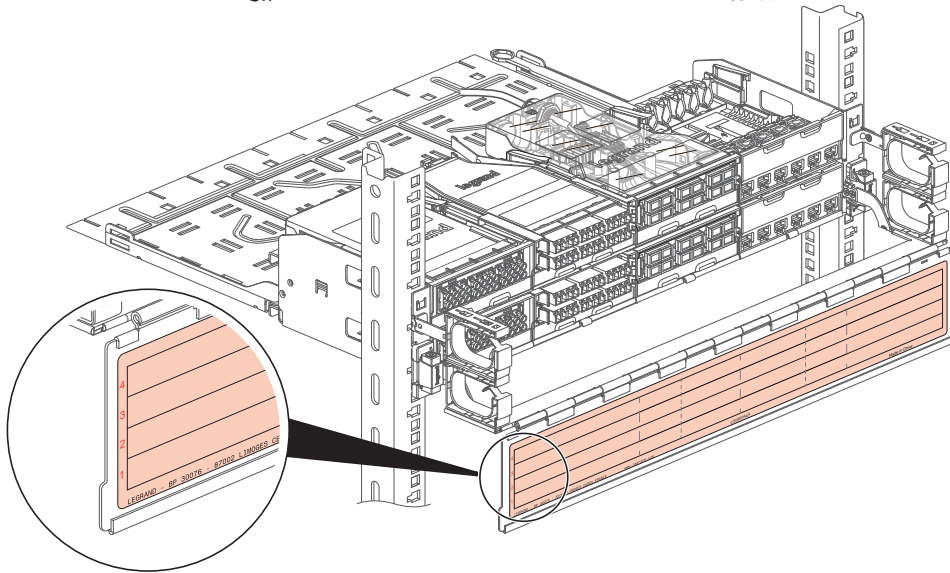

- Raccordement cassette préconnectée
- Connecting a pre-terminated cassette
- Anschluss vorverkabelte Kassette

- Conexión de casete preconectorizada
- Ön konektörlü kaset bağlantısı
- توصل علبه مزودة مسبقًا بأطراف توصيل (ترامل)

- Подсоединение кассеты с подготовленным разъемом
- Collegamento cassetta preconnettorizzata
- 连接预端接盒

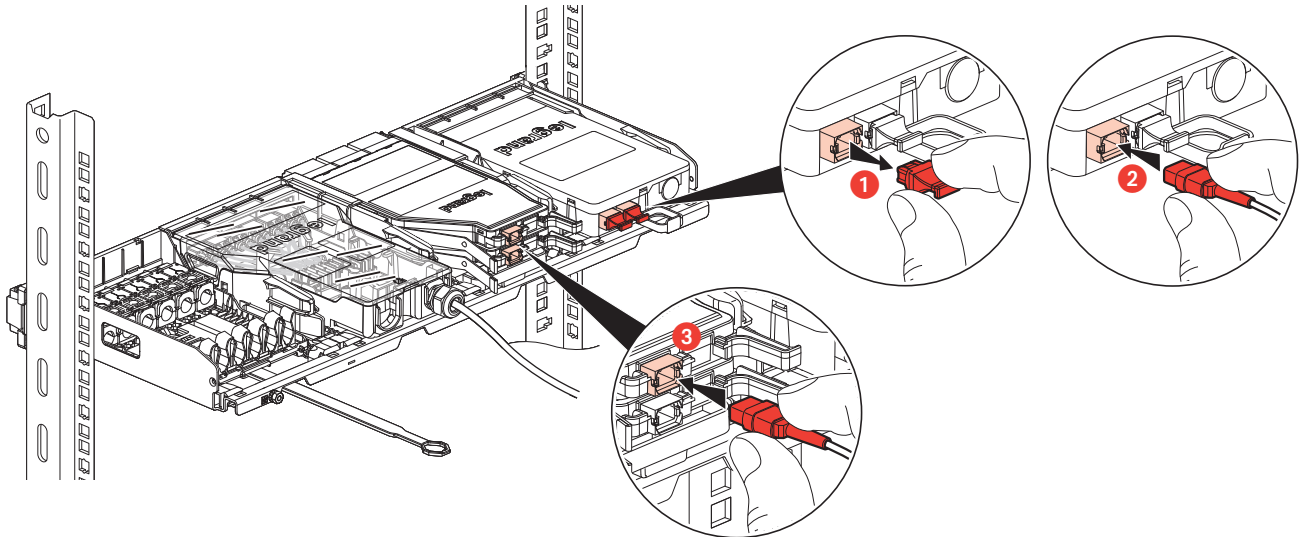

- Lovage câbles arrière
- Rear cable coiling
- Spleißung hinteres Kabel

- Enrollado de cables posteriores
- Arka kabloların dağıtımı
- لف كبلات خلفي

- Укладка кабелей сзади
- Avvolgimento cavi posteriore
- 后部电缆盘绕

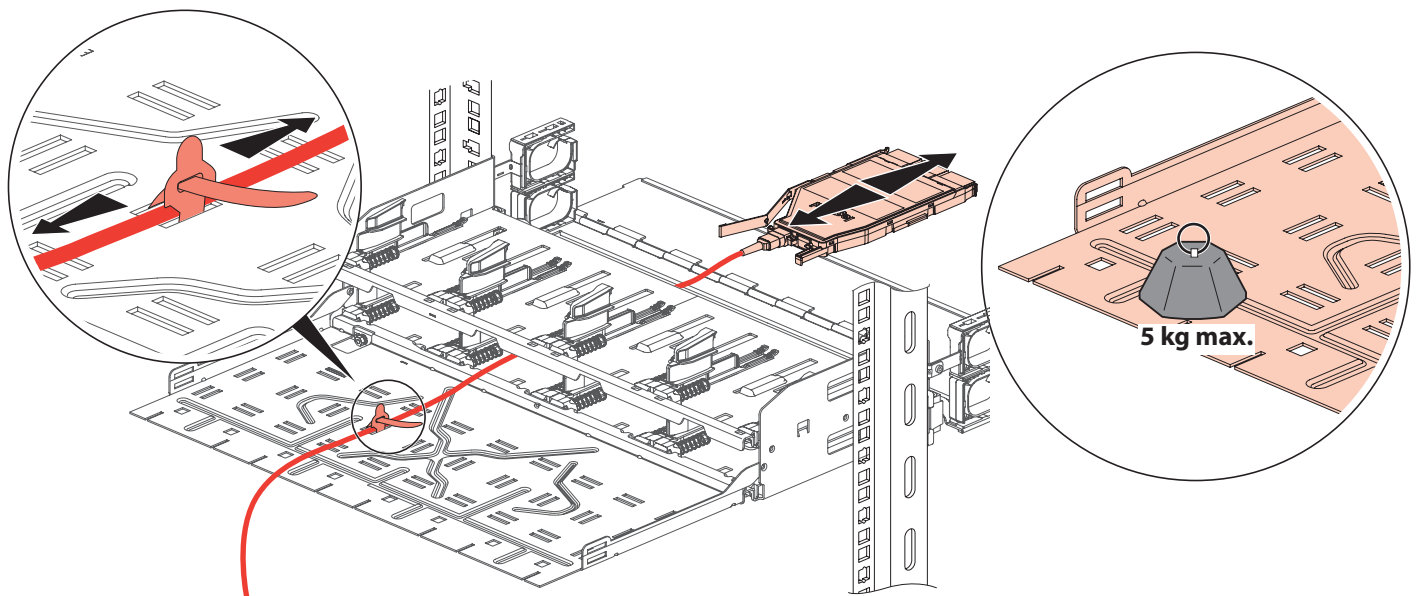

- Mise à la terre
- Earthing
- Erdung

- Puesta a tierra
- Topraklama
- التأسيس

- Заземление
- Messa a terra
- 接地

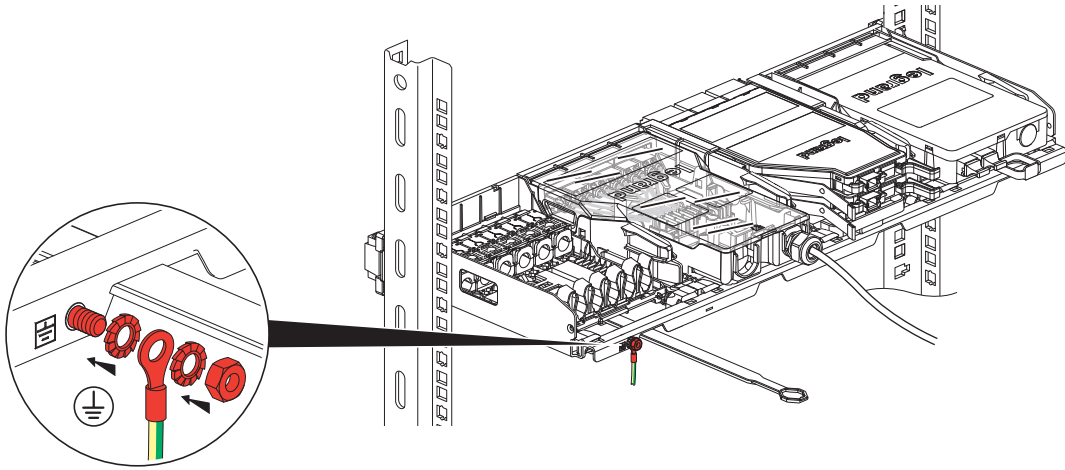

- Démontage cassette par l'avant
- Removing a cassette from the front
- Ausbau der Kasette von vorn

- Desmontaje frontal del casete
- Ön taraftan kaset demontajı
- فك علبة من الأمام

- Демонтаж кассеты спереди
- Smontaggio cassetta dal davanti
- 从前部拆下光纤盒

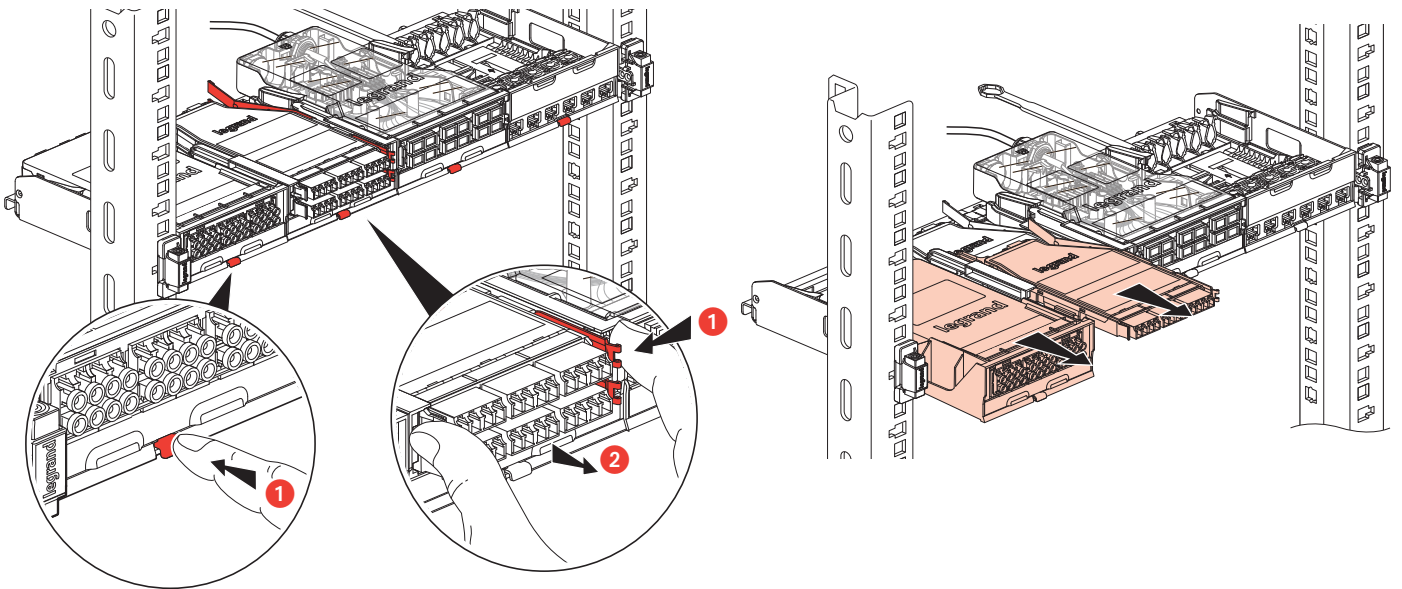

- Démontage cassette par l'arrière
- Removing a cassette from the back
- Ausbau der Kasette von hinten

- Desmontaje posterior del casete
- Arka taraftan kaset demontajı
- فك علبة من الخلف

- Демонтаж кассеты сзади
- Smontaggio cassetta da dietro
- 从后部拆下光纤盒

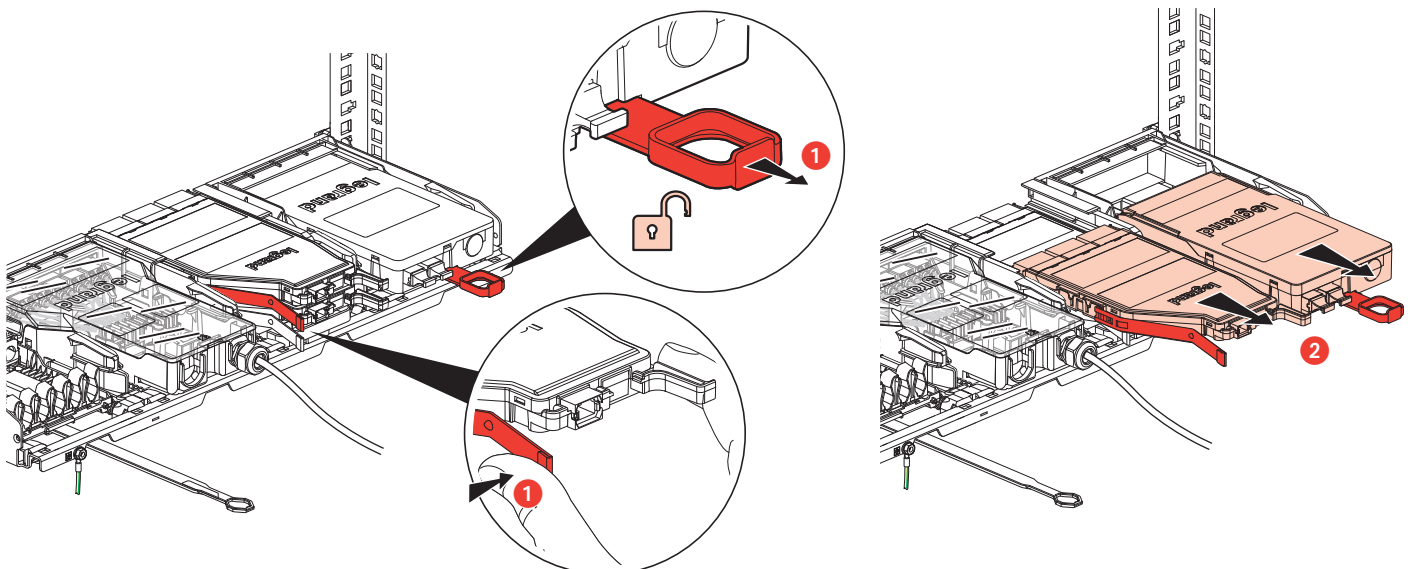

- Remontage cassette par l'arrière
- Reinstalling a cassette from the back
- Wiedereinbau der Kassette von hinten

- Montaje posterior del casete
- Arka taraftan kaset yeniden montajı
- فك علبة من الأمام

- Повторный монтаж кассеты сзади
- Rimontaggio cassetta da dietro
- 从后部重新安装光纤盒

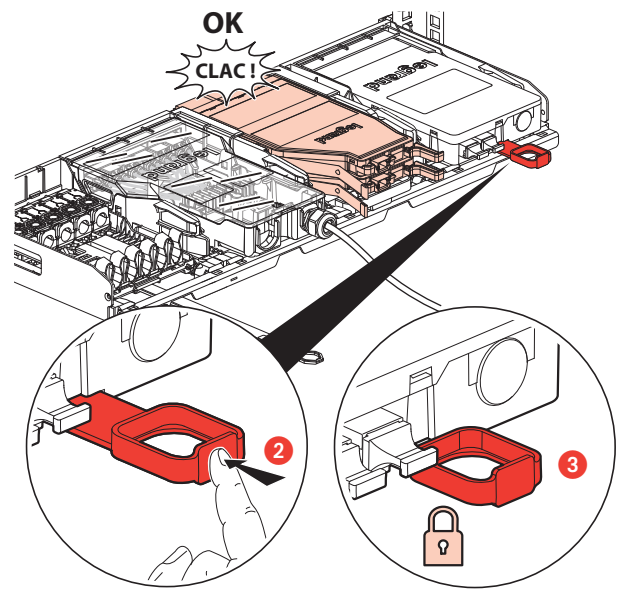
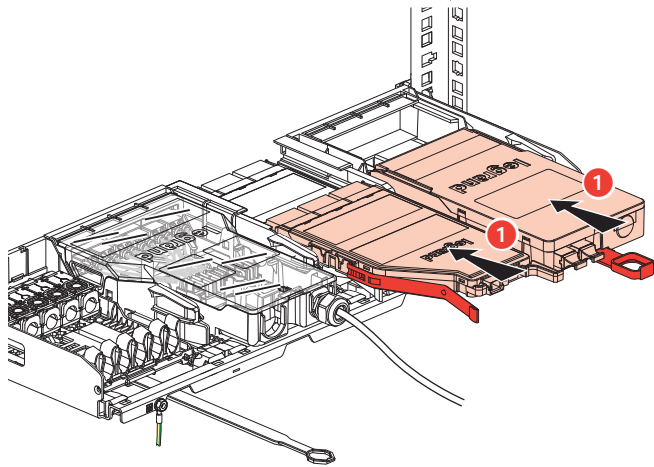

- Démontage management avant
- Removing the front management system
- Demontage vorderes Management

- Desmontaje de gestión frontal
- Ön yönetim demontajı
- فك نظام الإدارة الأمامي

- Демонтаж системы кабельного менеджмента спереди
- Smontaggio gestione anteriore
- 拆下前部管理系统

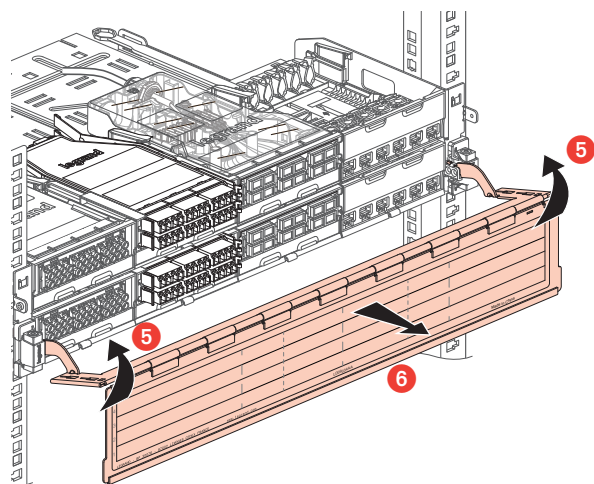
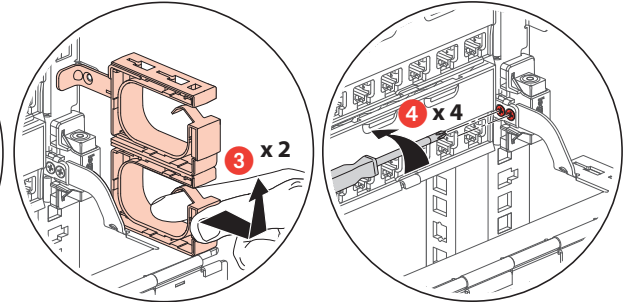
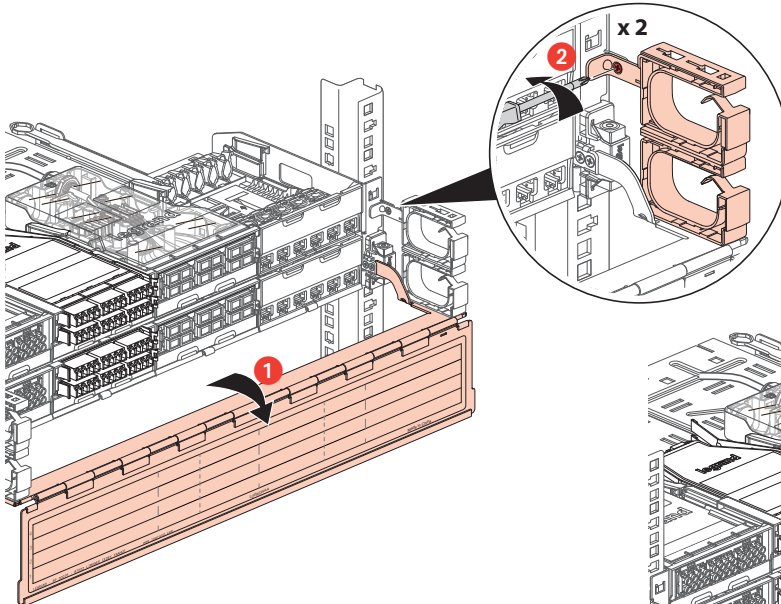

- Autres configurations
- Other configurations
- Andere Konfigurationen

- Otras configuraciones
- Diğer konfigürasyonlar
- تهيئات أخرى

- Другие конфигурации
- Altre configurazioni
- 其他配置

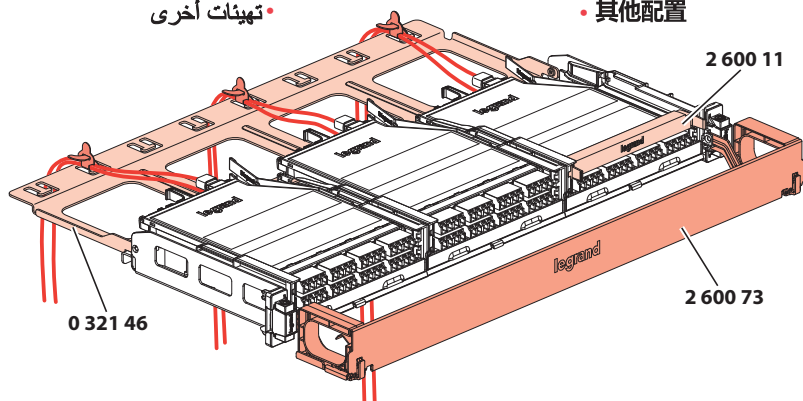

- Autres configurations
- Other configurations
- Andere Konfigurationen

- Otras configuraciones
- Diğer konfigürasyonlar
- تهيئات أخرى

- Другие конфигурации
- Altre configurazioni
- 其他配置

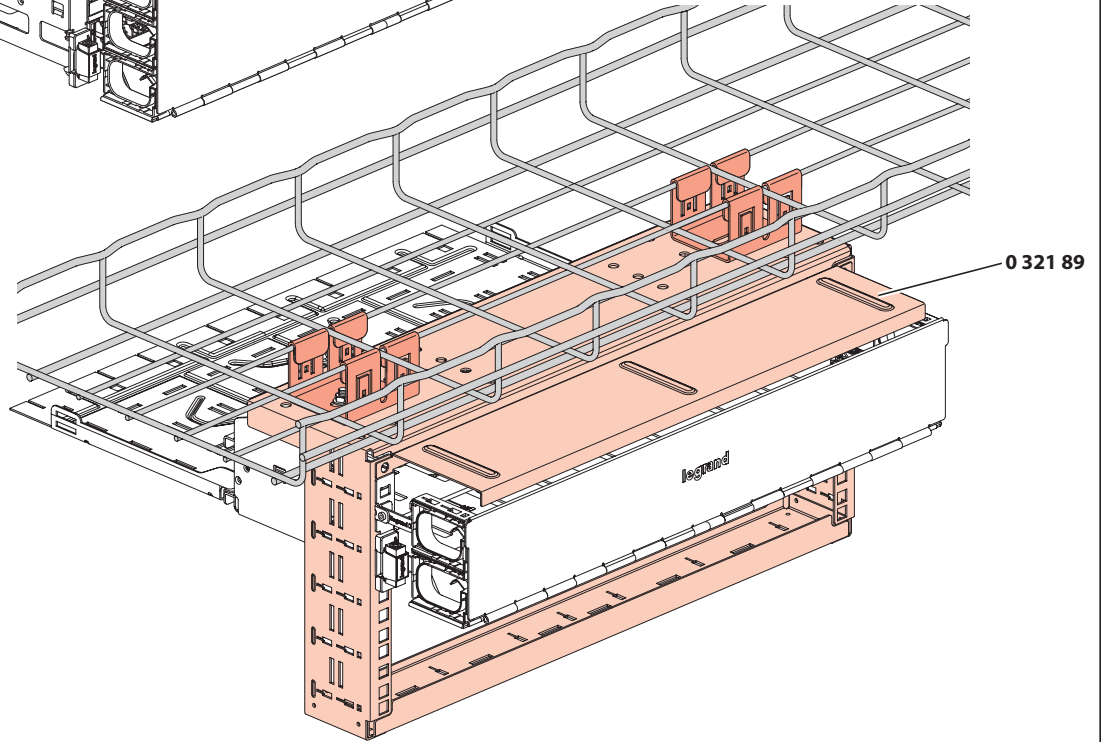
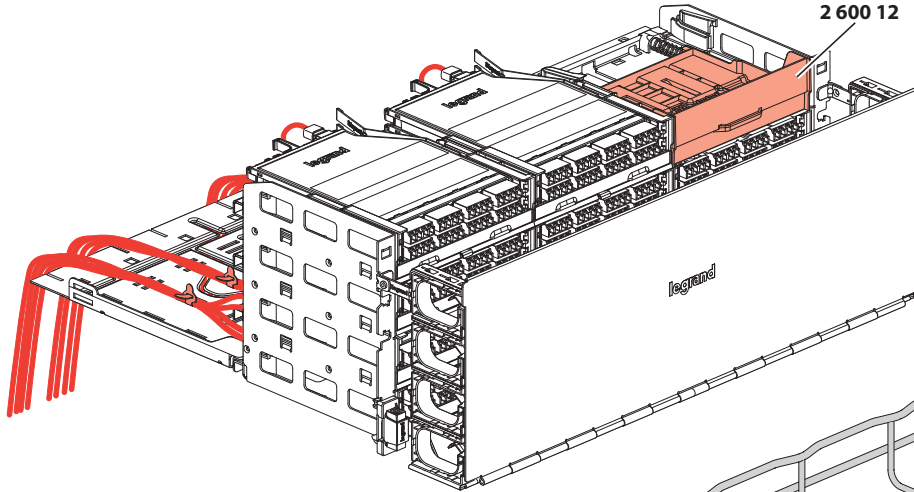

#### ⚠ Consignes de sécurité

Avant toute intervention, couper le courant.  
Respecter strictement les conditions d'installation et d'utilisation.

(FR) (LU) (BE) (CH)

Lors du maniement de produits fibre optique, le port de lunettes de protection adaptées permet d'éviter toute lésion.  
Ne jamais regarder directement l'extrémité d'une fibre optique connectée.  
Quand le système est sous tension, les émetteurs laser actifs sont susceptibles d'émettre un rayonnement invisible pouvant endommager l'oeil.

#### ⚠ Safety instructions

Make sure the power supply is disconnected before any intervention.  
Strictly comply with instructions for installation and use.

(GB) (IE)

Avoid injury by wearing appropriate eye protection when handling fiber optic products.  
Never look directly into the end of a connected optical fiber.  
When the system is powered on, active laser transmitters may emit invisible radiation that can cause eye damage.

#### ⚠ Sicherheitshinweise

Vor jeglichem Eingriff die Spannungsfreiheit sicherstellen.  
Einbau- und Gebrauchsanleitungen sind genau zu beachten.

(DE) (AT) (LI) (CH)

Bei der Handhabung von Glasfaserprodukten verhindert das Tragen einer angemessenen Schutzbrille Verletzungen.  
Niemals direkt in das Ende einer angeschlossenen Glasfaser schauen.  
Wenn das System eingeschaltet ist, können die aktiven Lasersender unsichtbare, für die Augen schädliche Strahlung aussenden.

#### ⚠ Consignes de seguridad

Antes de realizar cualquier intervención, cortar la corriente eléctrica.  
Respetar estrictamente las condiciones de instalación y uso.

(ES)

Quando manipule productos de fibra óptica, lleve gafas de protección adecuadas para evitar lesiones.  
Nunca mire directamente al extremo de una fibra óptica conectada.  
Quando el sistema está encendido, los emisores láser activos pueden emitir radiaciones invisibles que pueden dañar el ojo.

#### ⚠ Güvenlik talimatları

Herhangi bir müdahaleden önce, akımı kesiniz.  
Yerleştirme ve kullanım koşullarına titizlikle riayet ediniz.

(TR) (CY)

Fiber optik ürünleri kullanırken, yaralanmaları önlemek için uygun koruyucu gözlük takın.  
Bağlı bir optik fiberin ucuna asla doğrudan bakmayın.  
Sistem açıldığında, aktif lazer yayıcılar göze zarar verebilecek görünmez radyasyon yayabilir.

#### ⚠ إرشادات الأمان:

«اقطع التيار الكهربائي قبل أي تدخل. تقيّد تقيداً تاماً بشروط التركيب والاستخدام.»

تجنب الإصابة من خلال ارتداء وسيلة حماية مناسبة للعينين عند التعامل مع منتجات ألياف ضوئية.  
يُمنع مطلقاً النظر مباشرة داخل طرف ليفة ضوئية موصلة. بعد تنشغيل النظام، قد تصدر أجهزة إرسال الليزر النشطة إشعاعاً غير مرئي قد يسبب ضرراً للعينين.

#### ⚠ Меры предосторожности

Отключить питание перед проведением любых ремонтных работ.  
Строго соблюдайте требования к условиям монтажа и эксплуатации.

(RU)

При работе с оптоволоконным носите специальные защитные очки во избежание травм.  
Категорически запрещается смотреть прямо на наконечник подключенного оптоволоконного кабеля.  
Когда система находится под напряжением, активные лазерные излучатели способны генерировать опасное для глаза невидимое излучение.

#### ⚠ Istruzioni di sicurezza

Prima di qualsiasi intervento, interrompere l'alimentazione.  
Rispettare scrupolosamente le condizioni d'installazione e uso.

(IT) (CB)

Quando si maneggiano prodotti in fibra ottica, indossare occhiali di protezione appropriati serve per prevenire eventuali lesioni.  
Non guardare mai direttamente l'estremità di una fibra ottica collegata.  
Quando il sistema è sotto tensione, gli emettitori laser attivi possono emettere radiazioni invisibili che possono danneggiare gli occhi.

#### ⚠ 安全提示

在任何干涉以前一定要断电，严格遵守安全和使用的规定。  
处理光纤产品时，请佩戴合适的护目镜，避免受伤。  
切勿直视已连接的光纤末端。系统通电时，活动的激光发射器可能会发出不可见辐射，造成眼部损伤。