

	A
6 548 00/01/02/03/12	129 mm ± 1
6 548 08/09/10/11	219 mm ± 1

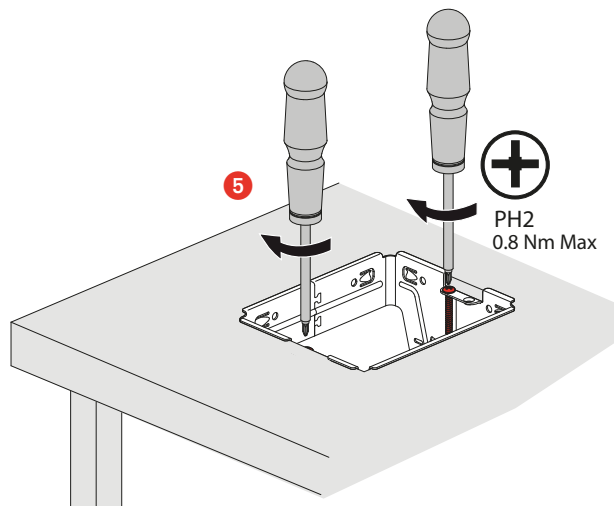

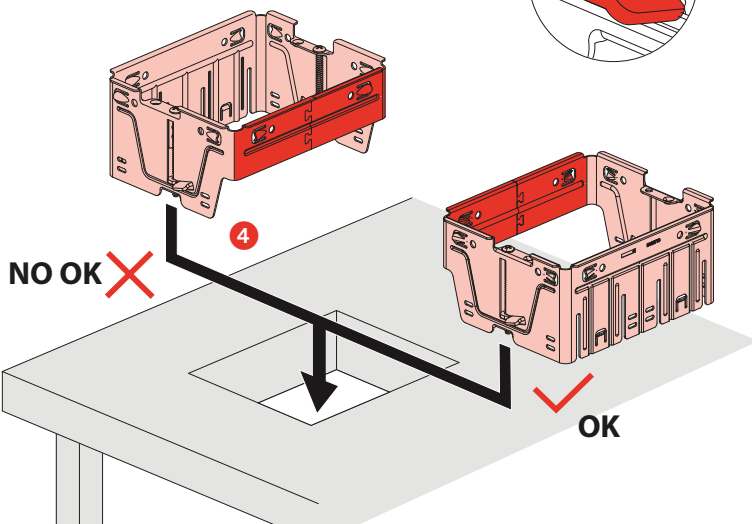

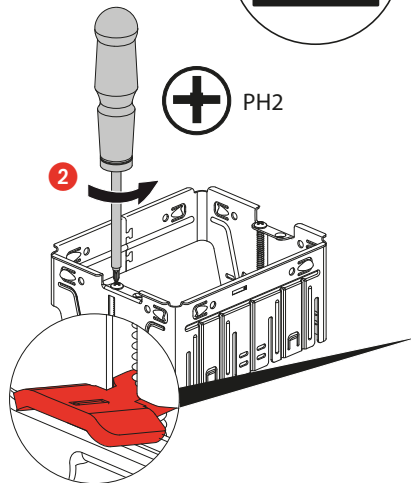
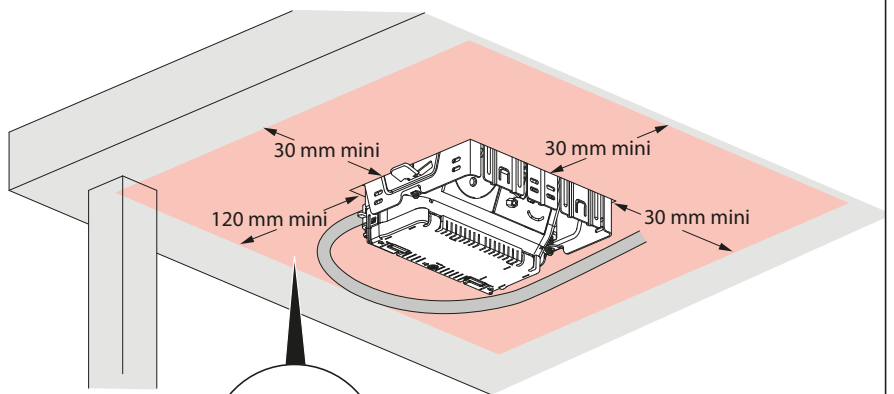
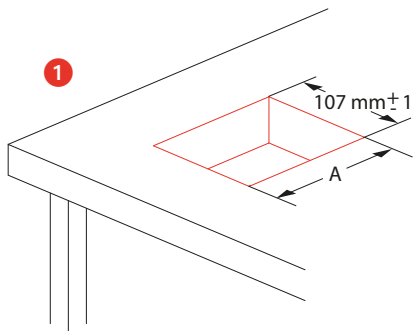
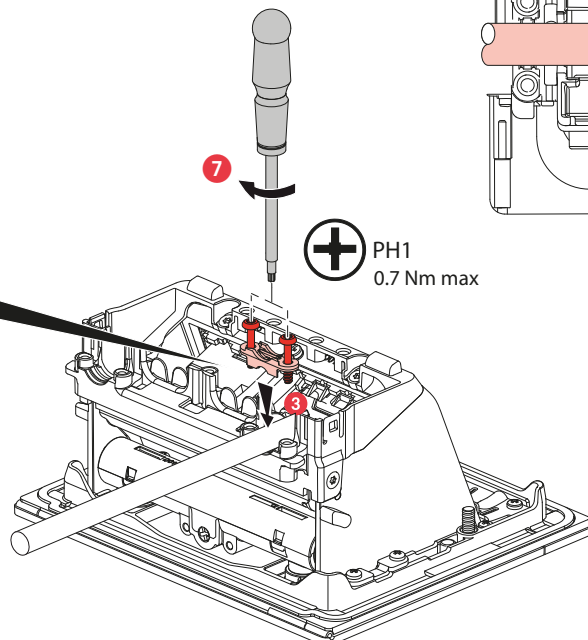
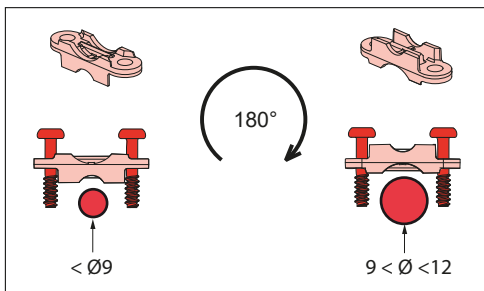
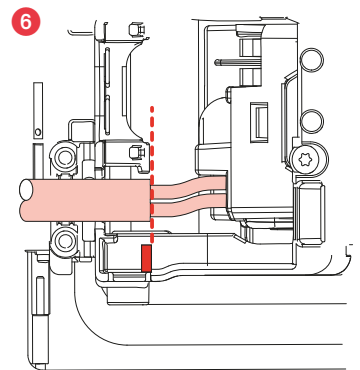
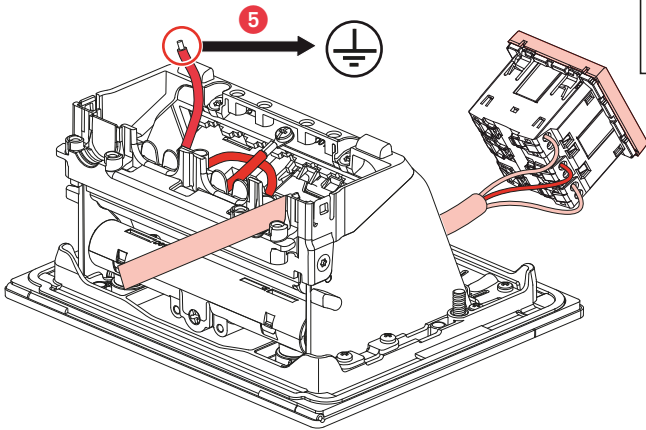
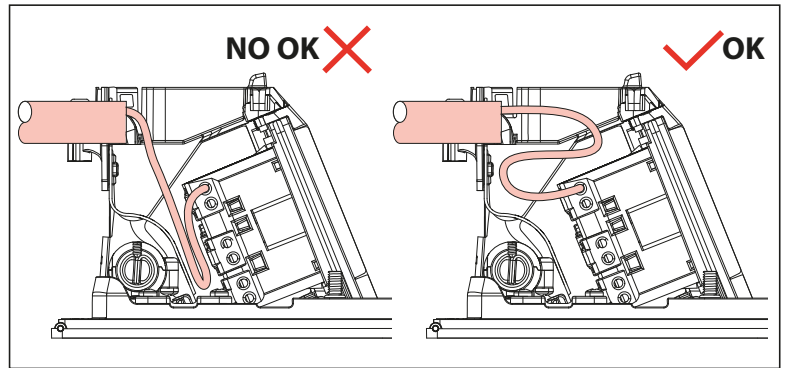
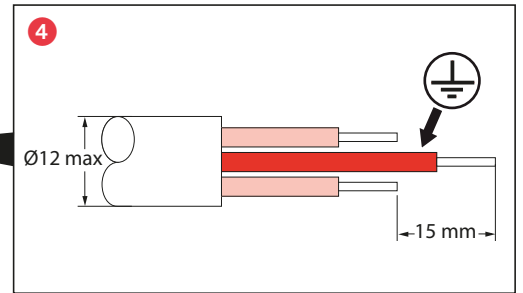
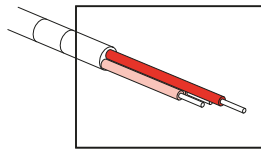
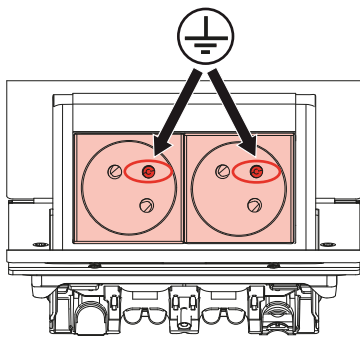
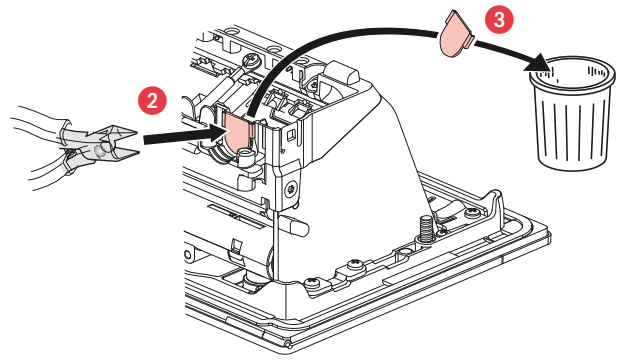
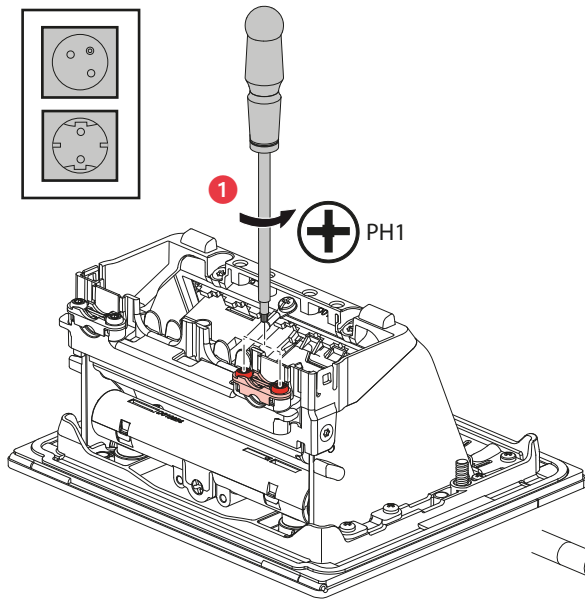
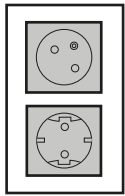
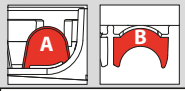
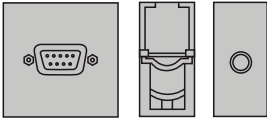

$D < \varnothing 3$



$\varnothing 3 < D < \varnothing 7$



A

$\varnothing 7 < D < \varnothing 9$



A + B

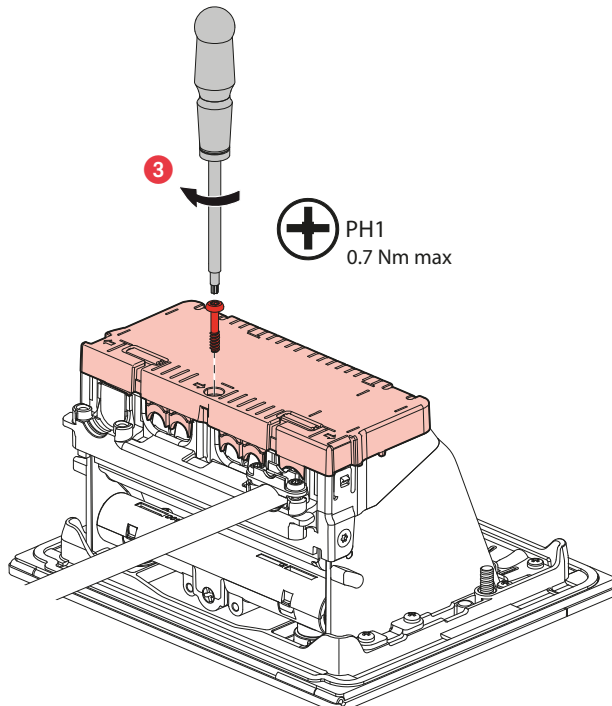
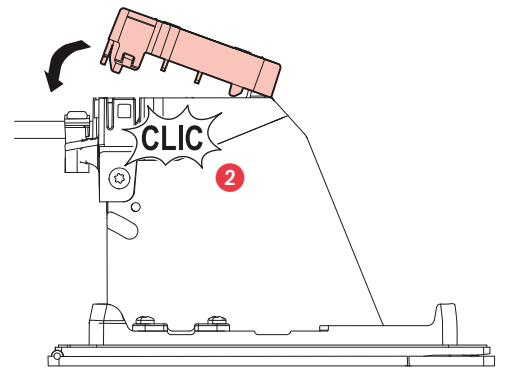
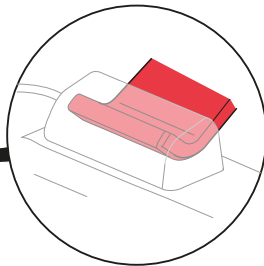
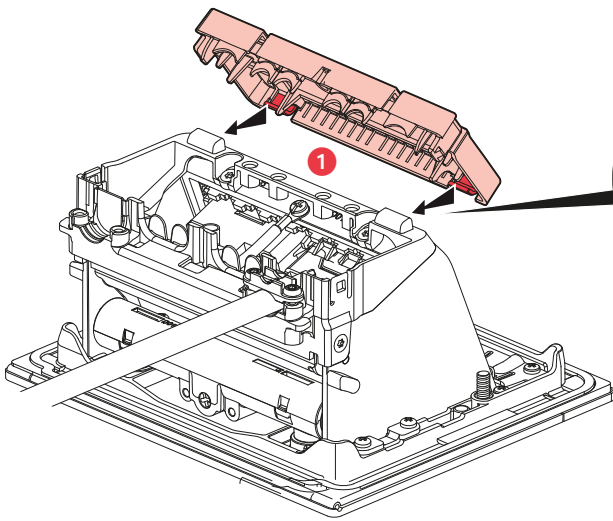
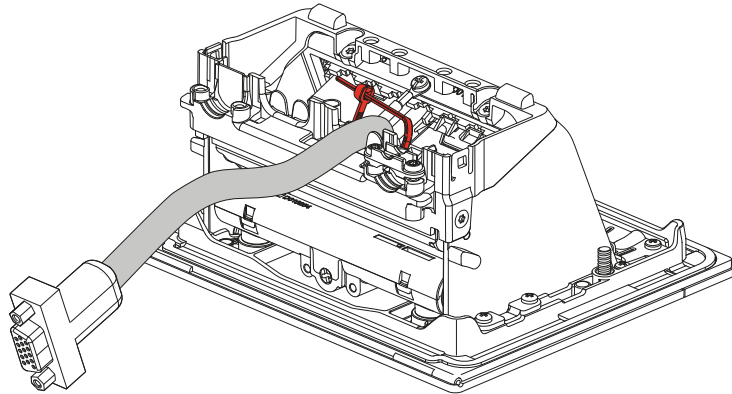
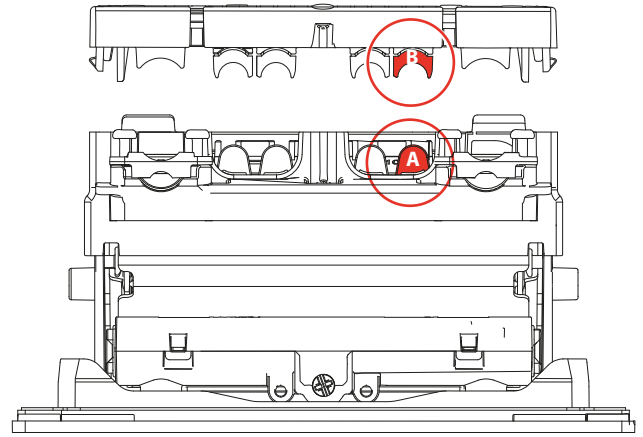

+ PH1
0.7 Nm max

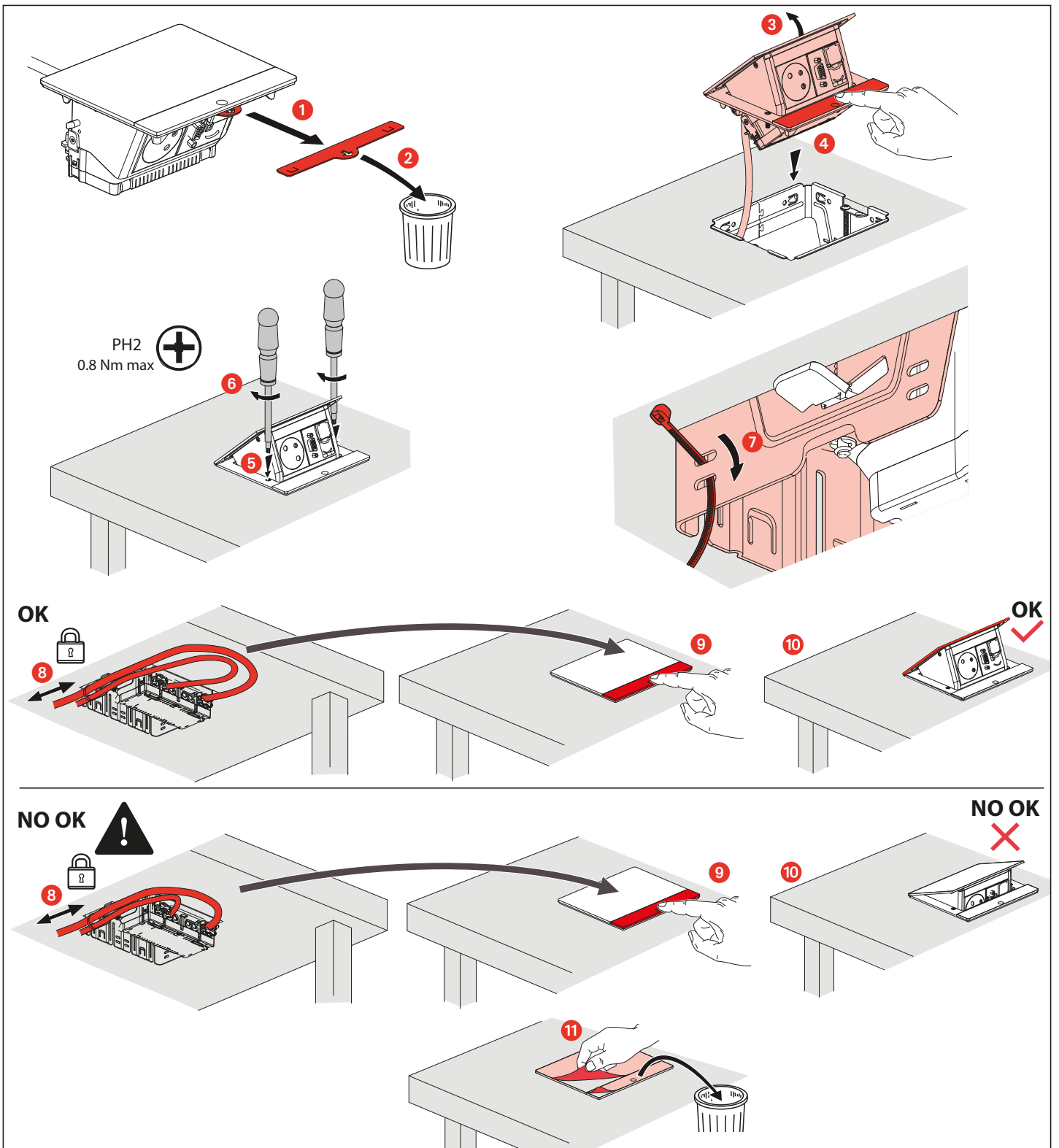

Consignes de sécurité (FR) (BE) (CA) (LU) (CH)
 Avant toute intervention, couper le courant.
 Respecter strictement les conditions d'installation et d'utilisation.

Veiligheidsvoorschriften (NL) (BE)
 Onderbreek voor enige ingreep de stroom.
 Neem de installatie- en gebruiksvoorwaarden nauwgezet in acht.

Safety instructions (GB) (CA) (IN) (IE) (US)
 Make sure the power supply is disconnected before any intervention.
 Strictly comply with instructions for installation and use.

Sicherheitshinweise (DE) (AT) (LI)
 Vor jeglichem Eingriff die Spannungsfreiheit sicherstellen.
 Einbau- und Gebrauchsanleitungen sind genau zu beachten.

Consignas de seguridad (ES) (CL) (CO) (CR) (MX) (PE) (US) (VE)
 Antes de cualquier intervención, cortar la corriente.
 Respetar estrictamente las condiciones de instalación y de utilización.

Istruzioni di sicurezza (IT) (CH)
 Prima di qualsiasi intervento, interrompere l'alimentazione.
 Rispettare scrupolosamente le condizioni d'installazione e uso.

Instruções de segurança (PT)
 Antes de qualquer intervenção, cortar a corrente.
 Respeitar estritamente as condições de instalação e utilização.

Przepisy bezpieczeństwa (PL)
 Przed każdą operacją na urządzeniu, odłączyć dopływ prądu.
 Ścisłe przestrzegać instrukcji dotyczących instalacji i użytkowania.

Güvenlik talimatları (TR) (CY)
 Herhangi bir müdahaleden önce, akımı kesiniz.
 Yerleştirme ve kullanim koşullarına titizlikle riayet ediniz.

Biztonsági előírások (HU)
 Minden beavatkozás előtt szakítsa meg az áramellátást.
 Tartsa be pontosan a beszerelési és használati feltételeket.

Turvallisuusmääräykset (FI)
 Ennen huoltoa, katkaise virta.
 Noudata asennus- ja käyttöohjeita tarkoin.

Säkerhetsinstruktioner (SE)
 Innan allt ingrepp, stäng av strömförsörjningen.
 Iaktta noggrant installations- och användningsföreskrifterna.

Bezpečnostní pokyny (CZ)
 Před jakýmkoliv zásahem odpojte napájení.
 Důsledně dodržujte instalační a uživatelské podmínky.

Bezpečnostné nariadenia (SK)
 Pred akýmkoľvek zásahom odpojte napájanie.
 Prísne dodržiavajte podmienky, za ktorých sa má prístroj inštalovať a používať.

Συστάσεις ασφαλείας (GR) (CY)
 Πριν από οποιαδήποτε επέμβαση, κόψτε το ρεύμα.
 Τηρήστε αυστηρά τις συνθήκες εγκατάστασης και χρήσης.

Varnostna navodila (SI)
 Pred vsakim posegom izključite električno napajanje.
 Natančno upoštevajte pogoje za montažo in uporabo.

Sikkerhedsregler (DK)
 Inden der foretages et hvilket som helst indgreb, skal strømmen afbrydes.
 Installations- og anvendelsesbetingelserne skal overholdes nøje.

Twissijiet (MT)
 L-ewwel u qabel kollox, itfi l-kurrent tad-dawl mill-mejn.
 Imxi skond l-istruzzjonijiet mogħtija għall-istallazzjoni u l-u'.

Ohutusnõuded (EE)
 Enne mistahes (hooldus) tööd eemaldage vooluvõrgust.
 Pidage täpselt kinni paigaldus- ja kasutamistingimustest.

Drošības noteikumi (LV)
 Pārtraukt strāvas padevi pirms ierīču tīrīšanas.
 Stingri ievērot uzstādīšanas un lietošanas noteikumus.

Saugos taisyklės (LT)
 Prieš atlikdami bet kokius veiksmus, išjunkite prietaisą iš elektros tinklo.
 Griežtai laikytis instalavimo ir naudojimo sąlygų.

Sikkerhetsinstrukser (NO)
 Bryt strømtilførselen før ethvert inngrep.
 Installasjons- og bruksbetingelsene må nøye overholdes.

Varuðarráðstafanir (IS)
 Loka barf fyrir straum áður en átt er við tækið.
 Fylgja skal vandlega öllum reglum um uppsetningu og notkun.

تعليمات السلامة (AR)
 اقطع التيار الكهربائي، قبل أي تدخل.
 تقيّد تقيداً تاماً بشروط التركيب والاستخدام.