



Keor MOD

EN

ENGLISH

3

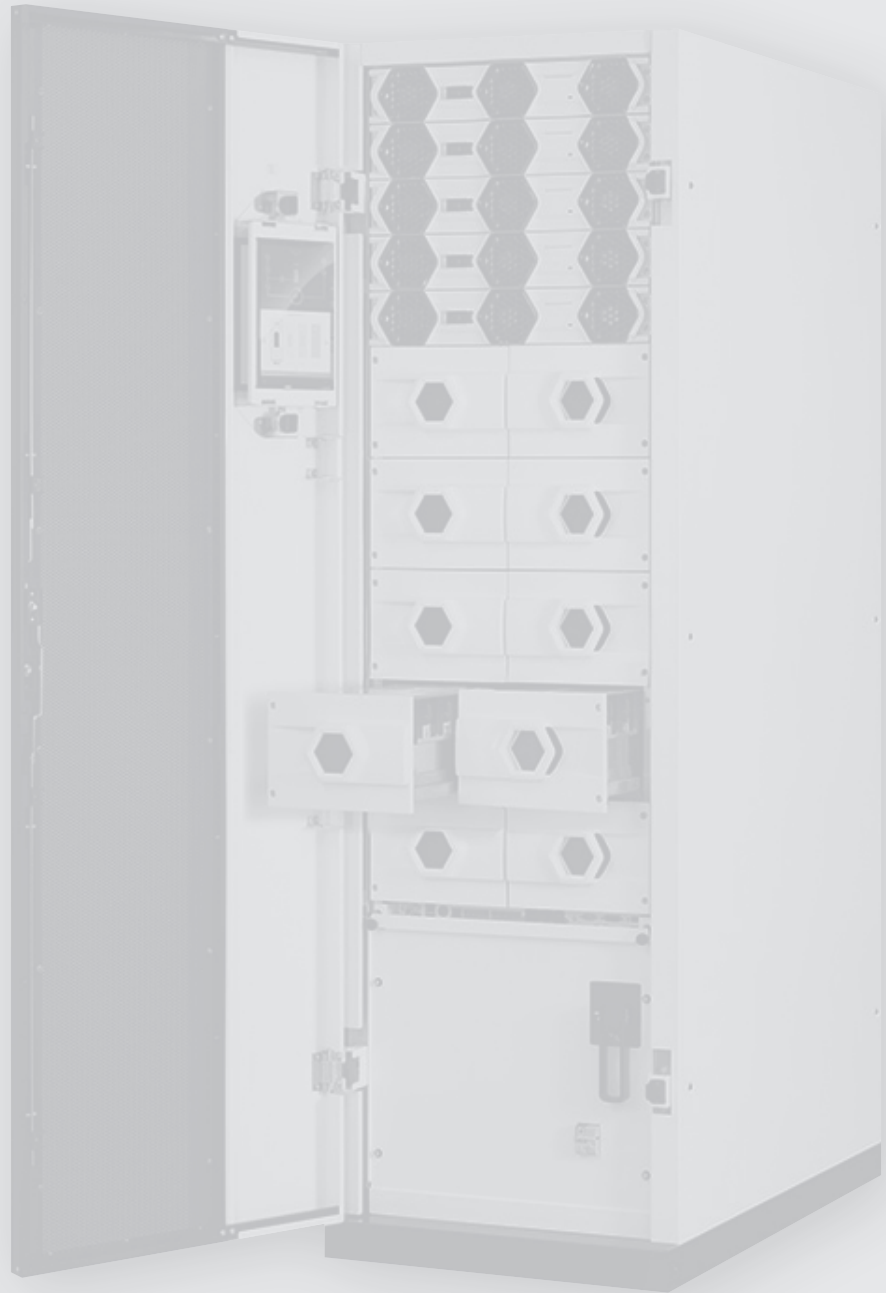

Table of Contents

1	Introduction	5
1.1	Purpose of the manual	5
1.2	Symbols in the manual	5
1.3	Where and how to keep the manual	5
1.4	Update of the manual	6
1.5	Manufacturer's liability and guarantee	6
1.5.1	Guarantee terms	6
1.5.2	Extension of the guarantee and maintenance contracts	7
1.6	Copyright	7
2.	Regulatory and safety requirements	8
2.1	General notes	8
2.2	Definitions of "Skilled Technician" and "Operator"	8
2.2.1	Skilled Technician	8
2.2.2	Operator	8
2.3	Personal Protective Equipment	8
2.4	Hazard signs in the workplace	9
2.5	Signs on the equipment	9
2.6	General warnings	10
2.7	How to proceed in an emergency	11
2.7.1	First-aid procedures	11
2.7.2	Fire procedures	11
3.	Transportation and placement	12
3.1	Visual check	12
3.2	Equipment check	12
3.3	Transportation	13
3.4	Unpacking	14
3.5	Placement	15
4.	Installation	17
4.1	Safety regulations	17
4.2	Electrical connections	17
4.2.1	Protective devices	18
4.2.2	Disassembly of the distribution panel	18
4.2.3	Earthing connection	23
4.2.4	Cable fastening	25
4.2.5	Backfeed protection	34
4.2.6	External battery cabinets installation	37
4.2.7	Input cables installation	38
4.2.8	Bypass cables installation	44
4.2.9	Output cables installation	48
4.2.10	Battery cables installation	52
4.2.11	Parallel system	61
4.2.12	Installation with STS (Static Transfer System)	67
4.3	Power modules installation	68
4.4	Battery drawers installation	70

Table of Contents

4.5	SSS interface	77
4.5.1	Emergency Power Off (EPO)	78
5.	Configuration and start-up	79
5.1	Pre-start-up checks	79
5.2	Start-up procedure	79
5.3	Turning off the UPS	85
6.	Maintenance	86
6.1	Preventive maintenance	86
6.2	Periodical checks	86
6.3	Ordinary maintenance	87
6.3.1	Hot-swap procedure for the replacement of power modules	87
6.3.2	Installation/replacement of power modules with the UPS in maintenance bypass mode	90
6.3.2.1	Setting the UPS in maintenance bypass mode	90
6.3.2.2	Installation/replacement of power modules	92
6.3.2.3	Exit the UPS from the maintenance bypass mode	94
6.3.3	Removal of the SSS drawer	95
6.4	Battery drawers replacement	96
6.4.1	Installation/replacement of battery drawers with UPS in on-line mode	97
6.4.2	Installation/replacement of battery drawers with UPS in maintenance manual bypass	99
6.5	Replacing the fuses and surge arrester (DIN rail)	100
6.6	Extraordinary maintenance	101
7.	Warehousing	102
7.1	UPS	102
7.2	Batteries	102
8.	Dismantling	103
8.1	Battery disposal	103
8.2	UPS dismantling	103
8.3	Electronic component dismantling	103
9.	Mechanical characteristics	104
9.1	Cabinets	104
9.2	Power module PM25	109
9.3	Battery drawer	110
9.4	Battery block	111
10.	Technical data	112
11.	Tables	117

1. Introduction



INDICATION

The instructions in this manual are intended for a **SKILLED TECHNICIAN** (paragraph 2.2.1)

1.1 Purpose of the manual

The purpose of this manual is to provide the skilled technician (see paragraph 2.2.1) with instructions for safely installing the Keor MOD UPS, also called "equipment" in the rest of the manual and carry out ordinary maintenance procedures.

Extraordinary maintenance operations are not dealt with because they are the sole preserve of the LEGRAND Technical Support Service.

The reading of this manual is essential but does not substitute the skill of technical personnel who must have received adequate preliminary training.

The intended use and configurations envisaged for the equipment as shown in this manual are the only ones allowed by the Manufacturer.

Any other use or configuration must be previously agreed with the Manufacturer in writing and, in this case, the written agreement will be attached to the installation and user manuals.

This manual also refers to laws, directives and standards that the skilled technician is required to be aware of and consult.

The original text of this publication, drafted in English, is the only reference for the resolution of disputes of interpretation linked to translations into other languages.

1.2 Symbols in the manual

Some operations are shown in graphic symbols that draw the attention of the reader to the danger or the importance they imply:



DANGER

This indication shows a danger entailing a high degree of risk that, if not avoided, will lead to death or serious injury or considerable damage to the equipment and things around it.



WARNING

This indication shows a danger entailing a medium degree of risk that, if not avoided, could lead to death or serious injury or considerable damage to the equipment and the things around it.



CAUTION

This indication shows a danger entailing a low level of risk that, if not avoided, could lead to minor or moderate injury or material damage to the equipment and the things around it.

INDICATION

This symbol indicates important information which should be read carefully.

1.3 Where and how to keep the manual

This manual must be kept in a safe, dry place and must always be available for consultation exclusively by the skilled technician.

It is recommended to make a copy of it and file it away.

If information is exchanged with the Manufacturer or the authorized assistance personnel, it is essential to refer to the equipment's rating plate data and serial number.

INDICATION

The manuals provided with the equipment are an integral part of it and must therefore be kept for its entire lifetime. In case of need (for example in case of damage that even partially compromises its consultation) the skilled technician is required to get a new copy from the Manufacturer, quoting the publication code on the cover.

1. Introduction

1.4 Update of the manual

The manual reflects the state of the art when the equipment was put onto the market. The publication conforms to the directives current on that date. The manual cannot be considered inadequate when new standards come into force or modifications are made to the equipment.

Any addition to the manual the Manufacturer considers appropriate to send to the users, must be kept together with the manual of which they will become an integral part.

The version of the manual updated to its latest release is available on the Internet at ups.legrand.com

1.5 Manufacturer's liability and guarantee

The skilled technician and the operator shall scrupulously comply with the precautions and installation instructions indicated in the manuals. They must:

- always work within the operating limits of the equipment;
- always carry out constant and careful maintenance through a skilled technician who complies with all the procedures indicated in the installation and maintenance manual.

The Manufacturer declines all indirect or direct responsibility arising from:

- assembly and cabling made by personnel not qualified and authorized by LEGRAND and not fully qualified according to national standards to work on equipment presenting electrical hazards;
- assembly and cabling made without using safety equipment and tools required by national safety standards;
- failure to observe the installation and maintenance instructions and use of the equipment which differs from the specifications in the manuals;
- use by personnel who have not read and thoroughly understood the content of the user manual;
- use that does not comply with the specific standards used in the country where the equipment is installed;
- modifications made to the equipment, software, functioning logic unless they have been authorized by the Manufacturer in writing;
- repairs that have not been authorized by the LEGRAND Technical Support Service;
- damage caused intentionally, through negligence, by acts of God, natural phenomena, fire or liquid infiltration;
- damage caused by the use of batteries and protections not specified in the manuals;
- damage caused by improper unloading and transportation after delivery of the equipment;
- accidents caused by a wrong assembly of the safety protections or due to the lack of application of the safety labels specified in the installation manual.

The transfer of the equipment to others also requires to hand over all the manuals. Failure to do it will automatically nullify any right of the buyer, including the terms of the guarantee where applicable.

If the equipment is sold to a third party in a country where a different language is spoken, the original owner shall be responsible for providing a faithful translation of this manual in the language of the country where the equipment will be used.

1.5.1 Guarantee terms

The guarantee terms may vary depending on the country where the UPS is sold. Check the validity and duration with LEGRAND's local sale representative.

If there should be a fault in the product, contact the LEGRAND Technical Support Service which will provide all the instructions on what to do.

Do not send anything back without LEGRAND's prior authorization.

The guarantee becomes void if the UPS has not been brought into service by a properly trained skilled technician qualified and authorized by LEGRAND (see paragraph 2.2.1).

If during the guarantee period the UPS does not conform to the characteristics and performance laid down in this manual, LEGRAND at its discretion will repair or replace the UPS and relative parts.

All the repaired or replaced parts will remain LEGRAND's property.

LEGRAND is not responsible for costs such as:

- losses of profits or earnings;
- losses of equipment, data or software;
- claims by third parties;
- any damage to persons or things due to improper use, unauthorized technical alterations or modifications;
- any damage to persons or things due to installations where the full compliance with the standard regulating the specific usage applications have not been guaranteed.

1.5.2 Extension of the guarantee and maintenance contracts

The standard guarantee can be consolidated in a single extension contract (maintenance contract).

Once the guarantee period has passed, LEGRAND is available for giving a technical assistance service able to meet all requirements, maintenance agreements, 24/7 availability and monitoring.

Please, contact the LEGRAND Technical Support Service for further information.

1.6 Copyright

The information contained in this manual cannot be disclosed to any third party. Any partial or total duplication of the manual by photocopying or other systems, including electronic scanning, which is not authorized in writing by the Manufacturer, violates copyright conditions and may lead to prosecution.

LEGRAND reserves the copyright of this publication and prohibits its reproduction wholly or in part without previous written authorization.

2. Regulatory and safety requirements



DANGER

Before carrying out any operation on the equipment, it is necessary to read the entire manual carefully, especially this chapter.

Look after this manual carefully and consult it repeatedly during installation and maintenance by a skilled technician.

2.1 General notes

The equipment has been made for the applications given in the manual. It may not be used for purposes other than those for which it has been designed, or differently from those specified in this manual.

The various operations must be carried out according to the criteria and the chronology described in this manual.

2.2 Definitions of “Skilled Technician” and “Operator”

2.2.1 Skilled Technician

The professional that will carry out the installation, start up and ordinary maintenance is called “Skilled Technician”.

This definition refers to people qualified by LEGRAND who have the specific technical qualification and are aware of the method of installing, assembling, repairing, bringing online and using the equipment safely.

In addition to the requirements listed in the paragraph below for a general operator, the Skilled Technician is qualified according to national safety standards to work under dangerous electrical voltage and uses the personal protective equipment required by national safety standards for all the operations indicated in this manual (see the examples listed in paragraph 2.3).

INDICATION

The safety manager is responsible for protection and company risks prevention according to what is indicated in European directives 2007/30/EC and 89/391/EEC regarding safety in the workplace.

The safety manager must ensure that all the people working on the equipment have received all the instructions concerning them in the manual, especially those contained in this chapter.

2.2.2 Operator

The professional assigned to the equipment for normal use is called “Operator”.

This definition refers to people who know how to operate the equipment defined in the user manual and have the following requisites:

1. technical education, which enables them to operate according to safety standards in relation to the dangers linked to the presence of electric current;
2. training on the use of personal protective equipment and basic first aid interventions.

The company safety manager, in choosing the person (operator) who uses the equipment, must consider

- the person's work fitness according to the laws in force;
- the physical aspect (not disabled in any way);
- the psychological aspect (mental stability, sense of responsibility);
- the educational background, training and experience;
- the knowledge of the standards, regulations and measures for accident prevention.

He shall also provide training in such a way as to provide thorough knowledge of the equipment and its component parts.

Some typical activities the operator is expected to carry out are:

- the use of the equipment in its normal functioning state and the restore of the functioning after it shuts down;
- the adoption of the necessary provisions for maintaining the quality performance of the UPS;
- the cleaning of the equipment;
- cooperation with personnel responsible for ordinary maintenance activities (Skilled Technicians).

2.3 Personal Protective Equipment





DANGER

The UPS poses a considerable risk of electric shocks and a high short circuit current. During installation, use and maintenance operations, the equipment mentioned in this section must be used.

People responsible for operating this equipment and/or passing close to it must not wear garments with flowing sleeves, nor may laces, belts, bracelets or other metal pieces that might cause a danger.

The following list sum up the minimum Personal Protective Equipment to wear always. Additional requirements may be needed according to national safety standards.



-  Anti-accident and non-sparking shoes with rubber sole and reinforced toe
-  Protective gloves for handling operations
-  Isolated rubber gloves for operations of connection and work under hazardous voltage
-  Protective garments for electrical work
-  Protective face and head shield
-   Isolated tools

INDICATION

The skilled technician must work on electrical insulated carpet and he must not wear any kind of metal objects like watches, bracelets, etc.

2.4 Hazard signs in the workplace

The following signs must be exhibited at all points of access to the room where the equipment is installed:

-  Electric current
This sign indicates the electrical live parts.
-  How to proceed in an emergency
Do not use water to quench fires but just the extinguishers specially designed for putting out fires in electrical equipment.
-  No smoking
This sign indicates that smoking is not allowed.

2.5 Signs on the equipment

Displayed on the UPS are explanatory plates that can vary depending on the country the equipment is intended for and constructional standards applied.

Make sure the instructions are adhered to. Removing these plates and working in a way that differs from what written there, is strictly prohibited.

The plates must always be clearly read and they must be cleaned periodically.

If a plate deteriorates and/or it is no longer legible, even partially, the Manufacturer must be contacted for another one.

CAUTION

The plates must not be removed or covered. Signs in different languages are provided along with the equipment to replace those in English. No other plates may be affixed to the equipment without the Manufacturer's prior written authorisation

2. Regulatory and safety requirements

WARNING

Potential risks can be drastically reduced by wearing the Personal Protective Equipment listed in this chapter, which are indispensable. Always operate with due care around dangerous areas marked by the appropriate warning notices on the equipment.

2.6 General warnings

DANGER

The UPS works with dangerous voltages. Only skilled technicians qualified and authorized by LEGRAND must perform the installation and ordinary maintenance operations. No part of the UPS can be repaired by the operator. Extraordinary maintenance operations must be carried out by LEGRAND Technical Support Service personnel.

DANGER

Before beginning any installation and/or maintenance operation, make sure that all the DC and AC power sources are disconnected.

The UPS and the external battery cabinet, if present, must be installed with an earth connection to avoid high leakage currents. First connect the earthing cable.

Check during each installation and/or maintenance operation the continuity of the earthing system.

DANGER

The UPS is powered by its own DC energy source (batteries). The output terminals may have a dangerous voltage even if the UPS is not connected to the AC power network.

Disconnect all battery drawers and external battery cabinets before performing any installation and/or maintenance operation.

WARNING

A battery can present a risk of electrical shock and burns by high short-circuit current. Failed batteries can reach temperatures that exceed the burn thresholds for touchable surfaces. The following precautions should be observed when working on batteries:

- a) remove watches, rings or other metal objects.
- b) use tools with insulated handles.
- c) wear rubber gloves and boots.
- d) do not lay tools or metal parts on top of batteries.
- e) disconnect the charging source prior to connecting or disconnecting battery terminals.
- f) determine if battery is inadvertently grounded. If inadvertently grounded, remove source from ground.
Contact with any part of a grounded battery can result in electrical shock. The likelihood of such shock can be reduced if such grounds are removed during installation and maintenance (applicable to equipment and remote battery supplies not having a grounded supply circuit).
- g) never leave live cable terminals without an insulated protection.
- h) When replacing batteries, replace with the same type and number of batteries or battery packs. There is the risk of explosion if batteries are replaced by an incorrect type.

Do not dispose of batteries in a fire. The batteries may explode.

Do not open or mutilate batteries. Released electrolyte is harmful to the skin and eyes. It may be toxic. The batteries installed inside the cabinet must be disposed of correctly. For the disposal requirements refer to local laws and relevant standards.

INDICATION

The UPS functions with TT, IT, TN-C and TN-S systems. The output neutral status is the same as the input neutral status. When the output load needs a different neutral status, it is necessary to place downstream of the UPS a suitably scaled isolation transformer that must be protected in compliance with the standards in force.

CAUTION

Do not open the battery fuse holders while the UPS is powering the loads in battery mode.

 **WARNING**

To reduce the risk of fire or electric shock, the UPS must work in closed, clean environments with controlled temperature and humidity. It must be kept away from inflammable liquids and corrosive substances. The room temperature must not be above +40°C (+104°F) and the relative humidity must be a maximum of 95% not condensing.

 **WARNING**

Keor MOD is a category C3 UPS according to the standard EN IEC 62040-2.

The UPS is a product for commercial and industrial application in the second environment – installation restrictions or additional measures may be needed to prevent disturbances.

INDICATION

When the UPS is used for special applications such as life support systems or any other application where a product failure is likely to cause substantial harm to people, it is mandatory to contact LEGRAND to confirm the possibility of the equipment to meet the requested level of safety, performance, reliability and compliance with applicable laws, regulations and specifications.

 **CAUTION**

- While maintenance operations are being carried out, "Maintenance work in progress" signs must be affixed in the department in such a way that they can be easily seen from any access area.
- The connection of the equipment (and of any accessory devices) signs must always be perfectly grounded to discharge short-circuit currents and electrostatic voltages. The input voltage must correspond with the value shown on the rating plate. Current adapters must not be used under any circumstances. Pay attention to polarity when connecting.
- Any intervention on the equipment must be done only after it has been disconnected from the power supply network by means of a switch disconnecter and must be locked with an appropriate padlock.
- The UPS must not be turned on if liquid is leaking from the batteries.
- Depositing flammable material near the equipment is strictly forbidden. The equipment should always be locked, and only specifically trained personnel are allowed access to it.
- Do not disable any safety, notification or warning device and do not ignore any alarm, warning message or notice, no matter whether they are generated automatically or represented by plates fixed to the equipment.
- Do not run the equipment with fixed protections not installed (panels etc.).
- In case of breaking, buckling or malfunctioning of the equipment or parts of it, repair or replace immediately.
- When replacing fuses, only use ones of the same type.
- The replacement of the batteries is an operation intended to be carried out by a skilled technician.
- Keep a register in which to enter the date, time, type, performer's name and any other useful information about each and any routine and extraordinary maintenance operation.
- Do not use oils or chemical products for cleaning because they could scratch, corrode or damage certain parts of the equipment.
- The equipment and workplace must be kept completely clean.
- Upon completion of the maintenance operations, before connecting the power supply, carefully check that no tools and/or material of any kind have been left next to the equipment.

INDICATION

The skilled technician must not leave at the disposal of the operator:

- the keys for opening the UPS door;
- the installation and maintenance manual.

2.7 How to proceed in an emergency

The following information are general. For the specific interventions consult the regulations in force in the country where the equipment is installed.

2.7.1 First-aid procedures

When administering first aid, adhere to the company rules and the usual procedures.

2.7.2 Fire procedures

Do not use water to quench fires but just the extinguishers specially designed for putting out fires on electrical equipment.

3. Transportation and placement

3.1 Visual check

On delivery of the UPS, carefully inspect the packaging and the equipment for any damage that might have occurred during transport. Check there is no damage to the indicator on the outer label reading "Shock Watch".

If there is possible or ascertained damage, immediately inform:

- the transporter;
- the LEGRAND Technical Support Service.

Check that the equipment corresponds with the items indicated in the delivery documentation.

If the UPS must be stored, follow the instructions of Chapter 7.

3.2 Equipment check

The equipment and the relative supplied accessories must be in perfect conditions.

Check that:

- the shipping data (address of the recipient, no. of packages, order no, etc.) correspond to what is contained in the delivery documentation;
- the technical rating plate data on the label applied to the UPS correspond with the material described in the delivery documentation;
- the documentation accompanying the equipment includes the installation and user manuals.

In case of discrepancy, immediately inform the LEGRAND Technical Support Service before commissioning the equipment.

The content of the supply is subject to thorough checking before the shipment. Nonetheless it is always advisable to check that it is complete and in order on receiving the material.

The following list is general:

- 1 UPS (empty cabinet) with keys to close the doors;
- 1 accessory box;
- user manual;
- installation and maintenance manual.

In case of defects and/or missing items, immediately inform the LEGRAND Technical Support Service before commissioning the equipment.

INDICATION

The installation manual must be used and consulted only by Skilled Technicians.

INDICATION

Power modules and battery drawers to be installed must be bought separately.

3.3 Transportation

⚠ WARNING

The UPS must be placed and stand in a vertical position throughout the transportation. It shall also be packed properly. Move the UPS very carefully, lifting it as little as possible and avoiding dangerous swings or falls. Follow always the directions indicated in the symbols present on the packaging. The equipment must always be handled by trained and instructed personnel. Comply with the safety regulations in force in your country relative to the usage of lifting equipment and/or accessories.

For any lifting, use a forklift or a transpallet with an adequate carrying capacity, placing the forks in the specific spaces of the base and making sure they come out on the other side by at least twenty centimetres.

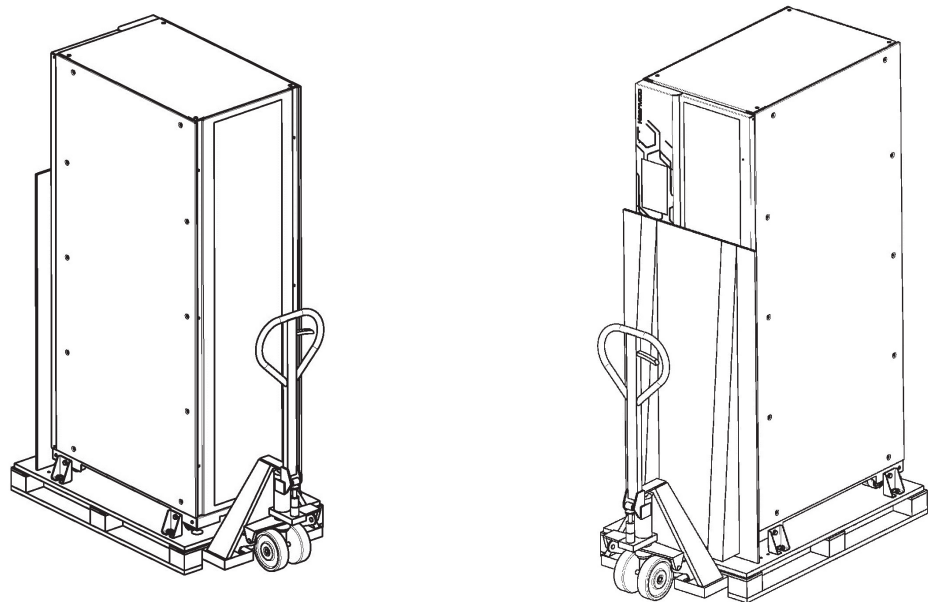

Keor MOD UPS has four wheels at the bottom of the cabinet. Before installations and while it is still empty, it can be moved by hand by at least two people.

⚠ CAUTION

Do not move the UPS after the installation or following the insertion of the power modules.

⚠ CAUTION

Do not stack more than 4 power modules.



**MAX
4 PCS
(22,5 Kg)**

3. Transportation and placement

3.4 Unpacking

To remove the packaging material, two people are required and they must comply with the following procedure:

- bring the UPS to the installation site using a forklift and/or a transpallet with suitable characteristics (see fig. 1);
- remove the plastic film and cardboards protecting the UPS;
- bring down the wooden chute attached to the pallet (fig. 2);
- loose the screws of the brackets that fix the equipment on the pallet (fig. 3);
- gently slide by hand the equipment along the chute using the wheels (fig. 4).

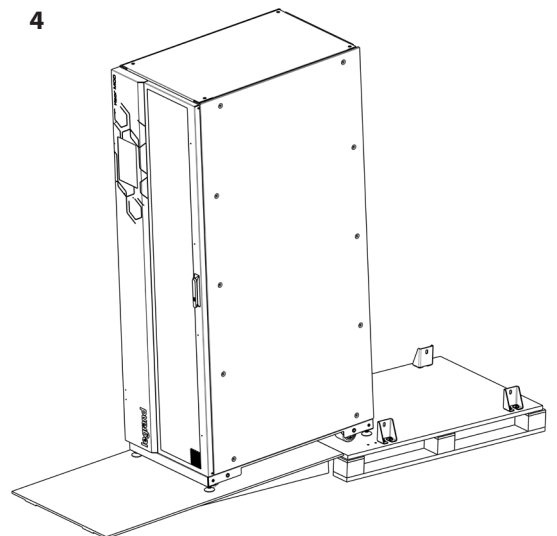
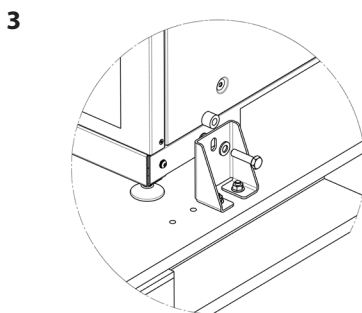
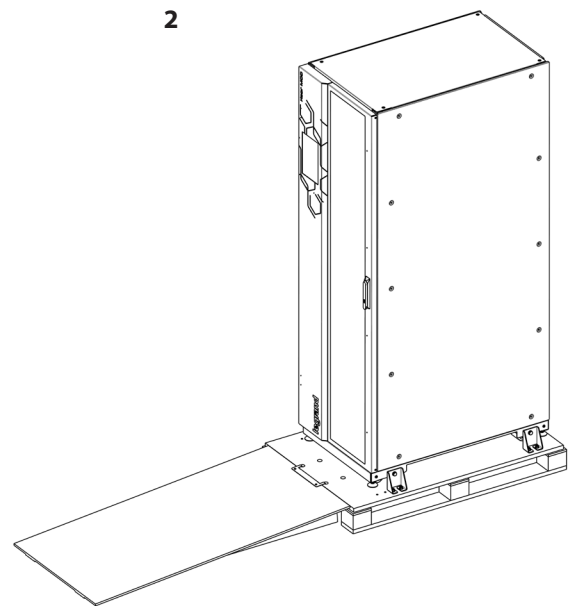
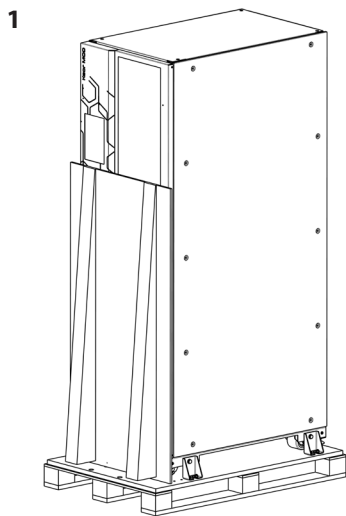

3.5 Placement

When the UPS is in the final position for the installation, unscrew counterclockwise the feet on the front and rear of the cabinet to position it.
Make sure that all the wheels and feet adhere to the floor.

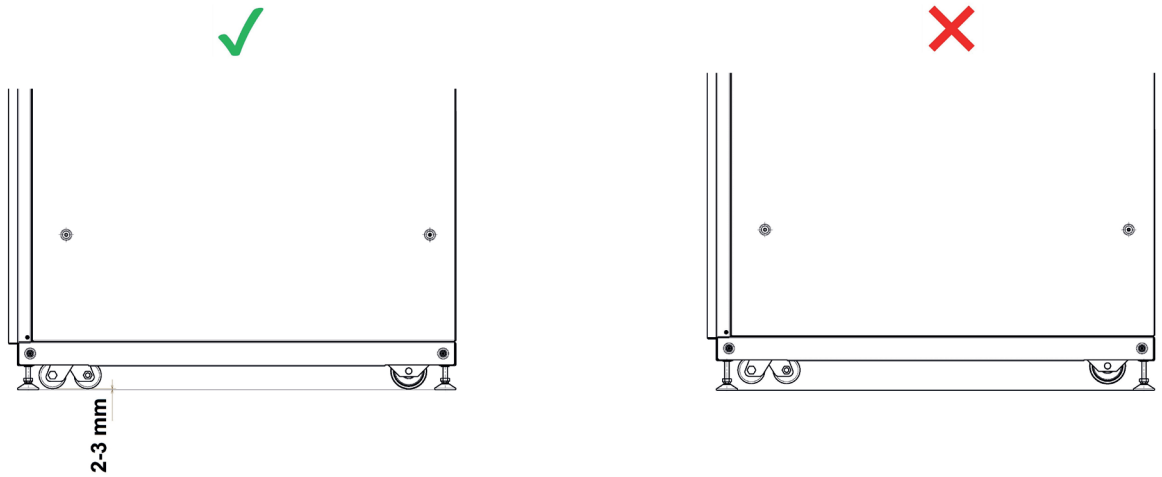
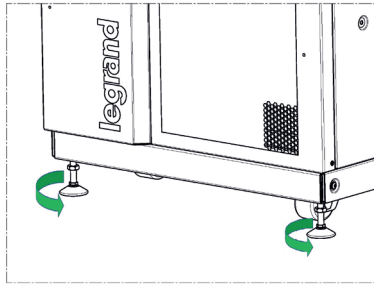

(all the dimensions are in mm)

3. Transportation and placement

The UPS must be positioned respecting the following conditions:

- do not cover the cooling vents of the power modules and keep a clearance of 20 cm beyond the cabinets real panels;
- keep a clearance of 160 cm on the front to allow the opening of the door;
- temperature and humidity must be within permitted limits;
- fire regulations must be respected;
- the wiring must be simply made;
- front and rear accessibility must be available for assistance or periodic servicing;
- the cooling flow of air must be guaranteed;
- the air conditioning system must be adequately sized;
- dust, corrosive and explosive atmospheres must be absent;
- the installation site must be free of vibration;
- the support surface must be sized for the weight necessary to support the equipment;
- regulate the equipment feet to have perfect perpendicularity and level of the UPS compare with the floor.

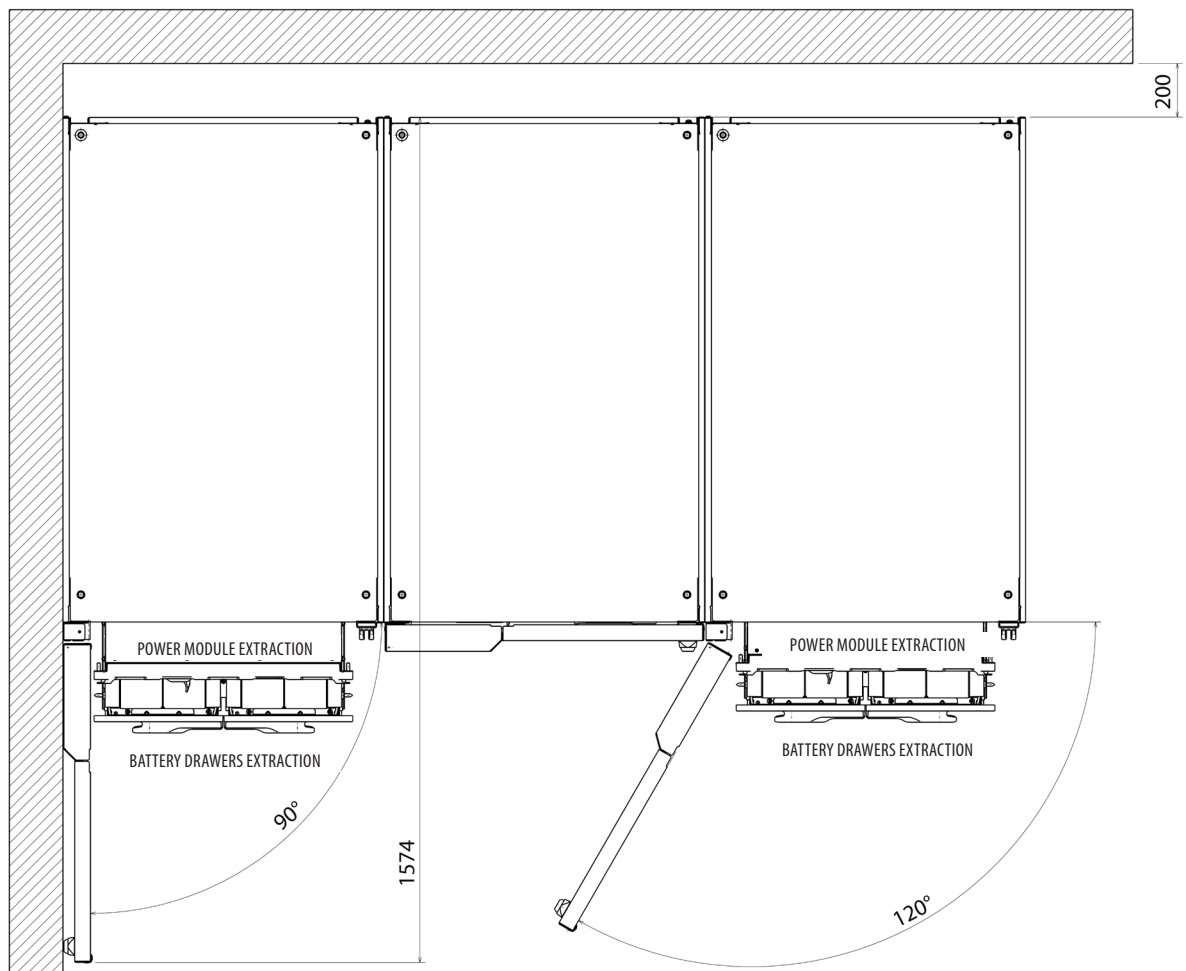

To safeguard the batteries as well as possible it is necessary to bear in mind that their average lifetime is strongly influenced by the operating room temperature. Position the UPS in an environment with a temperature range between +20°C (+68°F) and +25°C (+77°F) to guarantee the optimum life of the batteries.

Before proceeding with the installation operations, make sure that there is enough lighting to clearly see every detail. Provide artificial lighting if the natural lighting does not satisfy this requirement.

In case of maintenance operations in places that are not sufficiently well lit, portable lighting systems must be used, avoiding shadows that prevent or reduce visibility on the point where you intend to work or on the surrounding areas.

4. Installation



DANGER

All UPS installation operations must be carried out exclusively by a SKILLED TECHNICIAN qualified and authorized by LEGRAND (paragraph 2.2.1).

4.1 Safety regulations



DANGER

Before carrying out any installation operation you must read and apply the following:

- The UPS has a high leakage current. The earthing connection must be connected before cabling the UPS input. The switchgear must have a safe connection with the earthing and an adequate protection as required by the installation standards.
- The UPS must only be installed in a fixed way with a thermal-magnetic circuit breaker placed upstream of it. Connection to the mains via traditional type plug is not allowed.
- A circuit to protect from voltage backfeed made as in the diagrams shown in paragraph 4.2.5 must be provided outside the UPS.
- The switchgear or the disconnecter switch must be installed near the equipment and must be easily accessible.
- A warning label must be placed on all the mains disconnecter switches installed away from the area of the UPS to remind the assistance personnel of the fact that the circuit is connected to a UPS. The label must contain the following or equivalent text:

Before working on this circuit

- Isolate Uninterruptible Power System (UPS)
- Then check for the presence of Hazardous Voltage between all terminals including the protective earth



Risk of Voltage Backfeed

- Do not carry out the installation in presence of water or humidity.
- Open only the UPS panels necessary for the electrical connections. After that, close and fix them.
- Check there is no mains voltage on the equipment.
- Check that the loads are off and disconnected from the UPS.
- Check that the UPS is off and no voltage is present.
- Check that the fuse breakers on the external battery cabinets (if present) are open.
- Check that all battery drawers (if present) are not fully inserted in the UPS cabinet.
- Check that the mains input voltage and frequency correspond with the values indicated in the technical data on the UPS rating plate.
- Check that the earthing has been carried out in compliance with IEC (International Electrotechnical Commission) standards or local regulations.
- Check that the electrical system has been fitted with the necessary differential and thermal-magnetic protections upstream of the UPS.
- The energy quality of the electrical network should comply with the individual voltage harmonics compatibility levels defined by IEC/EN 61000-2-2. For more severe conditions, a power quality audit is required during the UPS commissioning by the LEGRAND Technical Support Service in order to check the compatibility.

4.2 Electrical connections

The electrical hook-up of the UPS to the switchgear or to the external battery cabinets is part of the installation that is not normally performed by the UPS manufacturer. For this reason, the indications that follow are to be considered approximate and it is recommended that the electrical connections are based on local installation standards.

After removing the UPS from the packaging and positioning it in its definitive place, the Skilled Technician can begin to make the electrical connections.



WARNING

The choice of cables type and their cross sections depending on the rated current and their installations must be made as indicated by the local installation standards and it is a responsibility of the Skilled Technician.

The input current and the output power of the UPS are indicated in chapter 10 and the battery current in table 5 of chapter 11. The cables used for the installation must have a maximum operating temperature of at least 70°C.

INDICATION

Chapter 11 includes tables with the recommended cables, fuses, automatic and differential breakers.

4. Installation

4.2.1 Protective devices

To ensure proper protection from overloads, output short-circuits or electrical shocks, it is necessary to install adequate automatic residual-current and thermal-magnetic breakers upstream of the UPS on the input line. In case there is a separate bypass line, the residual current earth leakage protection system must be common for the AC input and bypass lines and must be installed upstream.

The protective devices must be selected according to the indications in the tables shown in chapter 11.



CAUTION

The equipment can cause a d.c. current in the PE conductor. Where a residual current-operated protective device (RCD) is used for protection against electrical shock, only an RCD of Type B is allowed on the supply side of this product.

4.2.2 Disassembly of the distribution panel

To carry out all the electrical connection operations, it is necessary to unscrew the screws that fix the distribution panel to the cabinet. The screws must be saved to close the distribution panel at the end of the installation (hex socket M6x20 screws along with M6 toothed washers).

Unscrew also the screws that fix the plexiglass protection panel and save them to close the panel and the end of the installation (Phillips pan head M4x10 screws).

The following pictures show how to disassemble the panels:

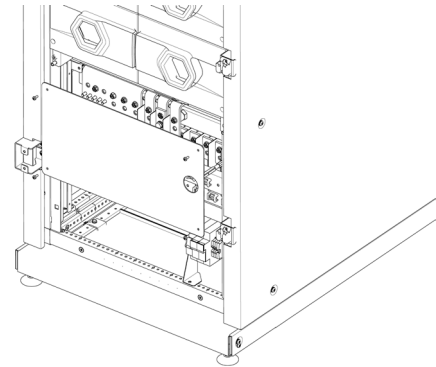
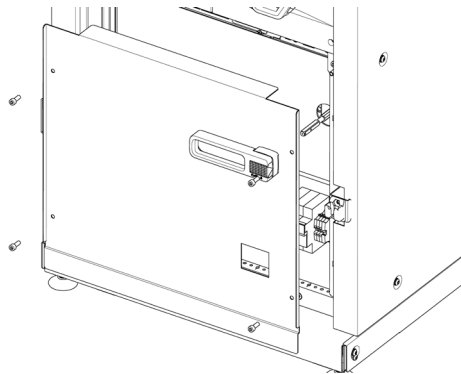

KEOR MOD 125

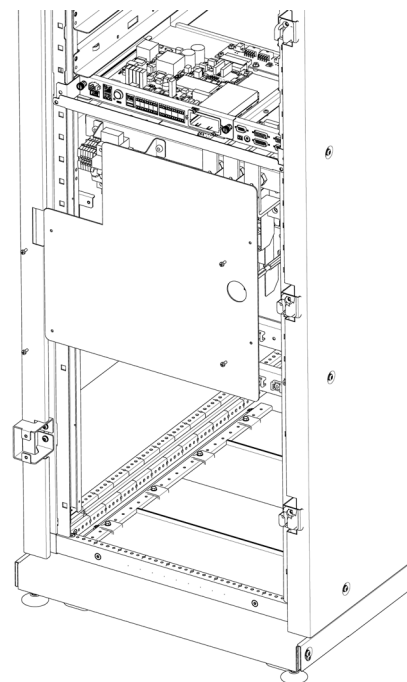
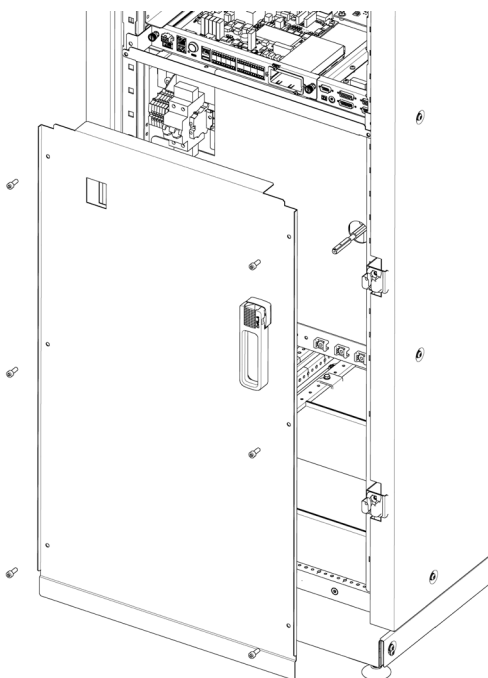

KEOR MOD 250

To insert the cables in the cabinet, it is necessary to remove the panels at the bottom of the cabinet according to the following sequence:

1

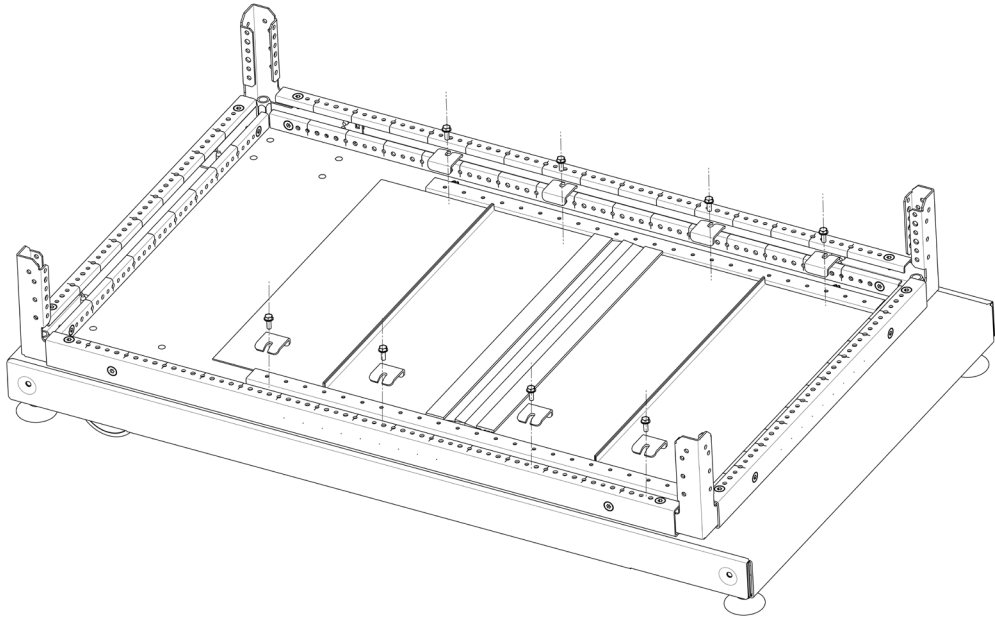

2

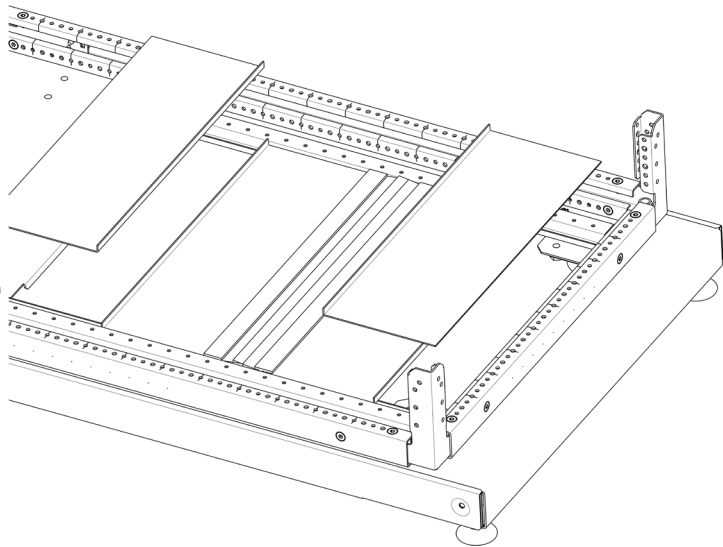

4. Installation

3

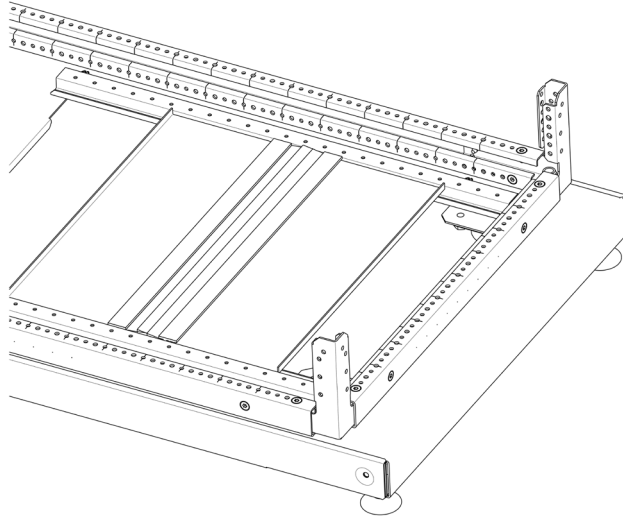

4

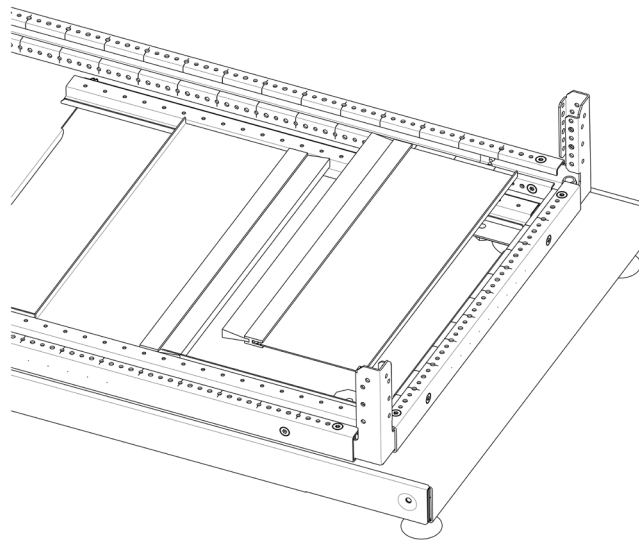

5

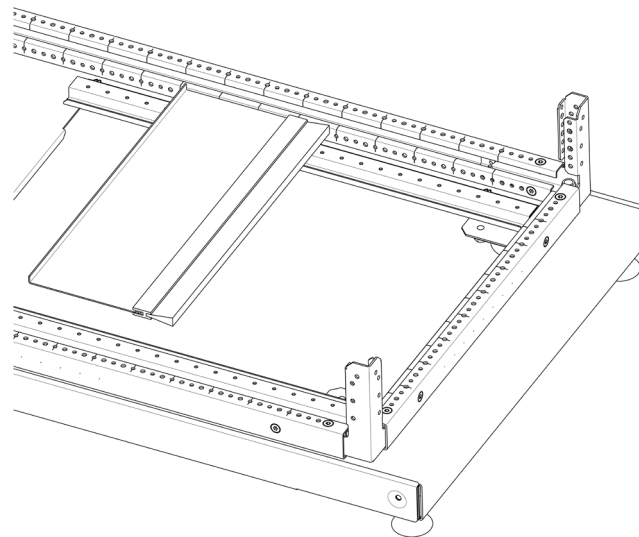

Insert the cable and add the panels according to the following sequence:

6

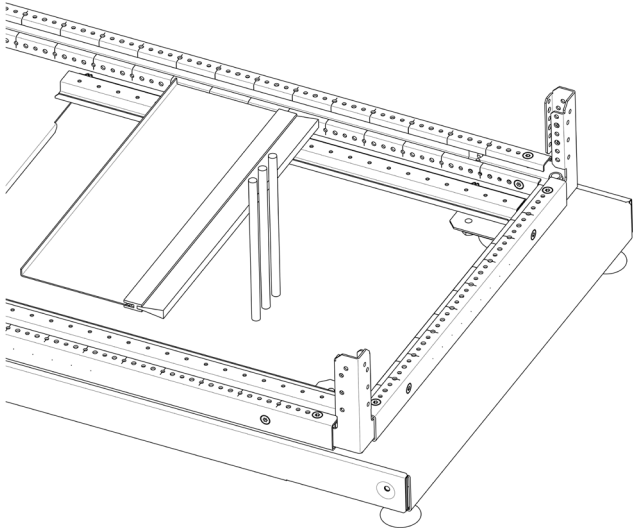

7

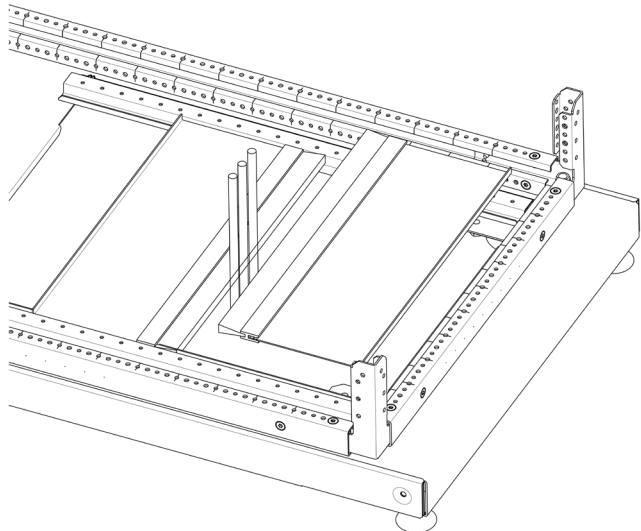

8

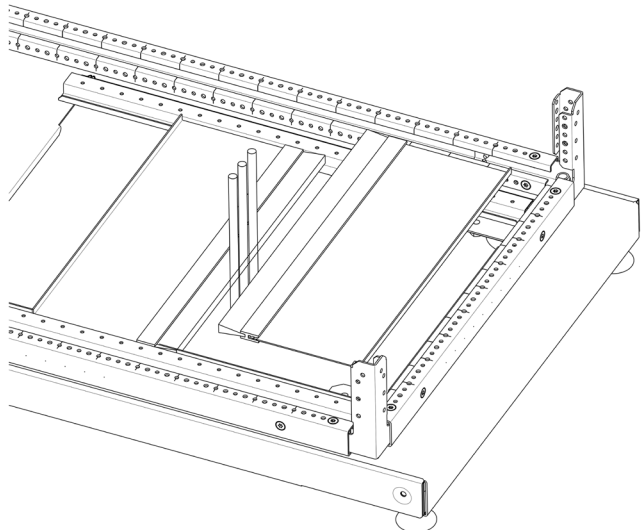

4. Installation

9

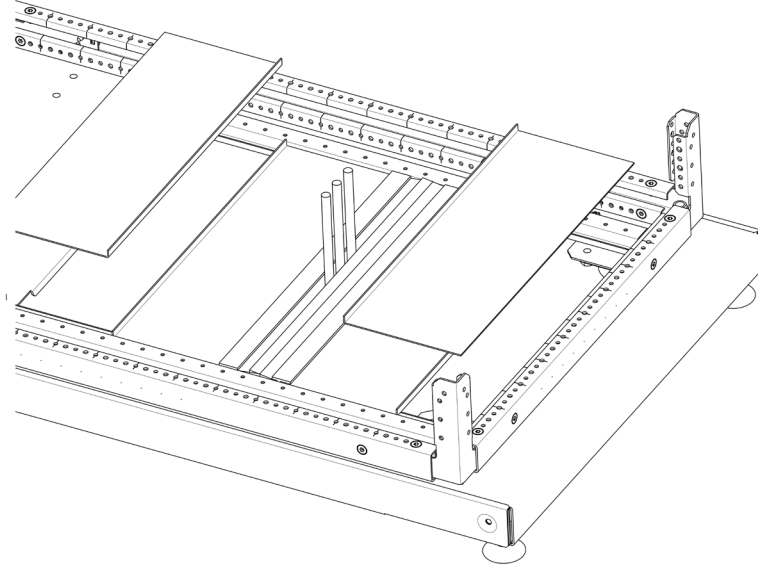

10

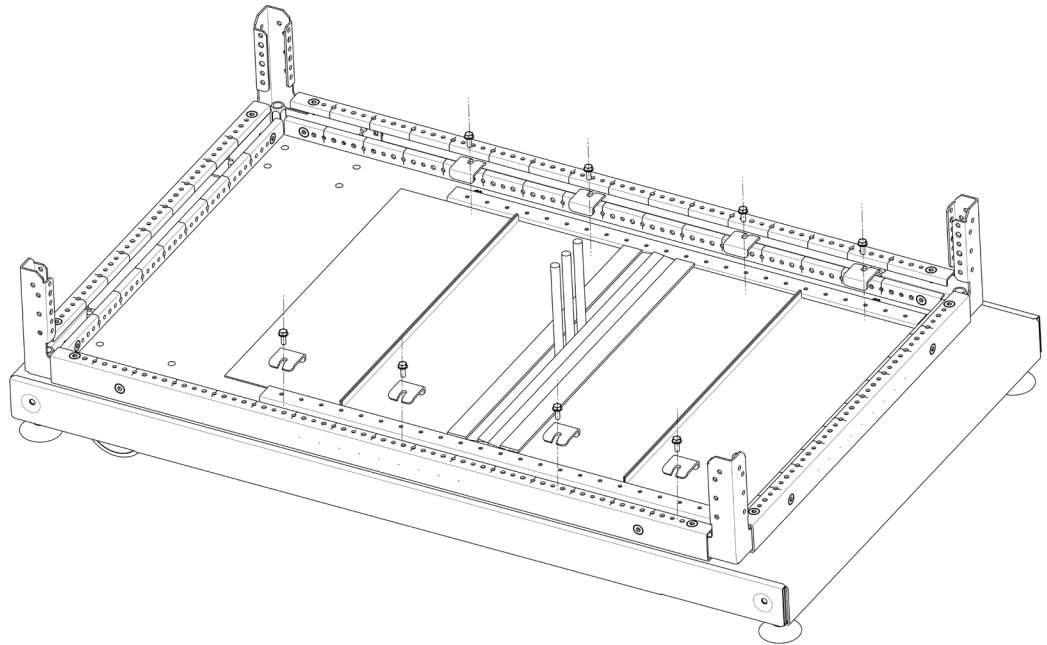

4.2.3 Earthing connection

Before carrying out any other installation operation, connect the earthing wiring coming from the low voltage switchgear to one of the earthing bars located on the left and right side of the busbars connection system.

The minimum cross-sectional area of the earthing conductor must be chosen according to the following criteria:

- if the cross-sectional area S of the phase conductors is $S \leq 16 \text{ mm}^2$, the minimum cross-sectional area of the earthing conductor must be the same as the phase conductors;
- if the cross-sectional area S of the phase conductors is $16 \text{ mm}^2 < S \leq 35 \text{ mm}^2$, the minimum cross-sectional area of the earthing conductor must be 16 mm^2 ;
- if the cross-sectional area S of the phase conductors is $S > 35 \text{ mm}^2$, the minimum cross-sectional area of the earthing conductor must be $S/2 \text{ mm}^2$.

Each earthing cable must be crimped with M8 eyelets and fixed to the earthing metal bar using hex M8x20 screws along with M8 flat washers and M8 grower washer.

The grower washer must be put on the top of the flat washer.

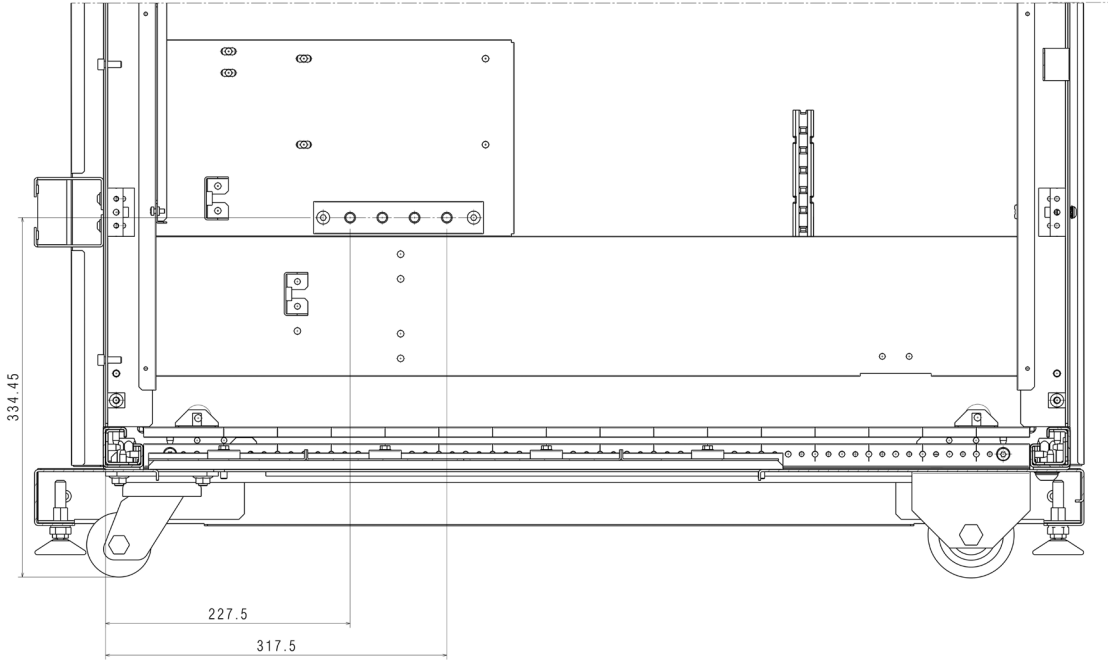
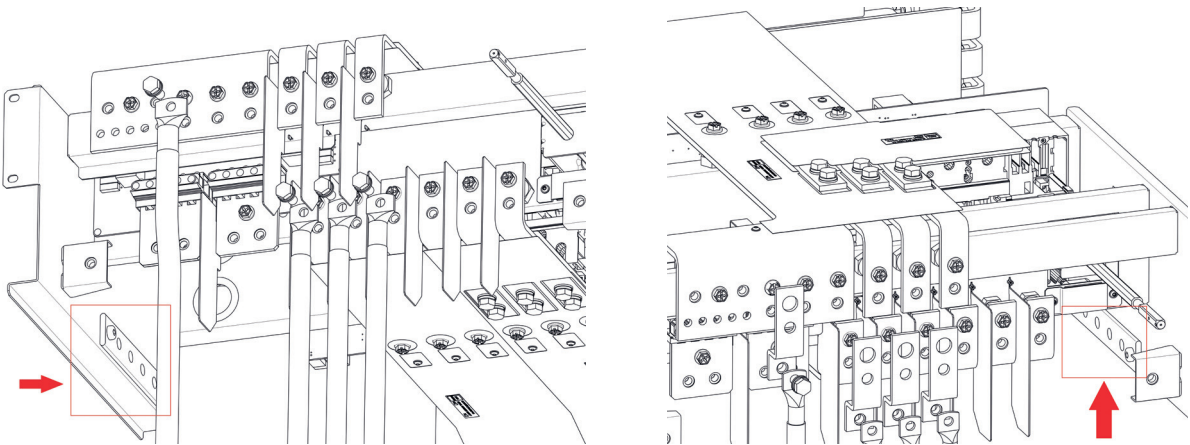

KEOR MOD 125 – earthing bars

4. Installation

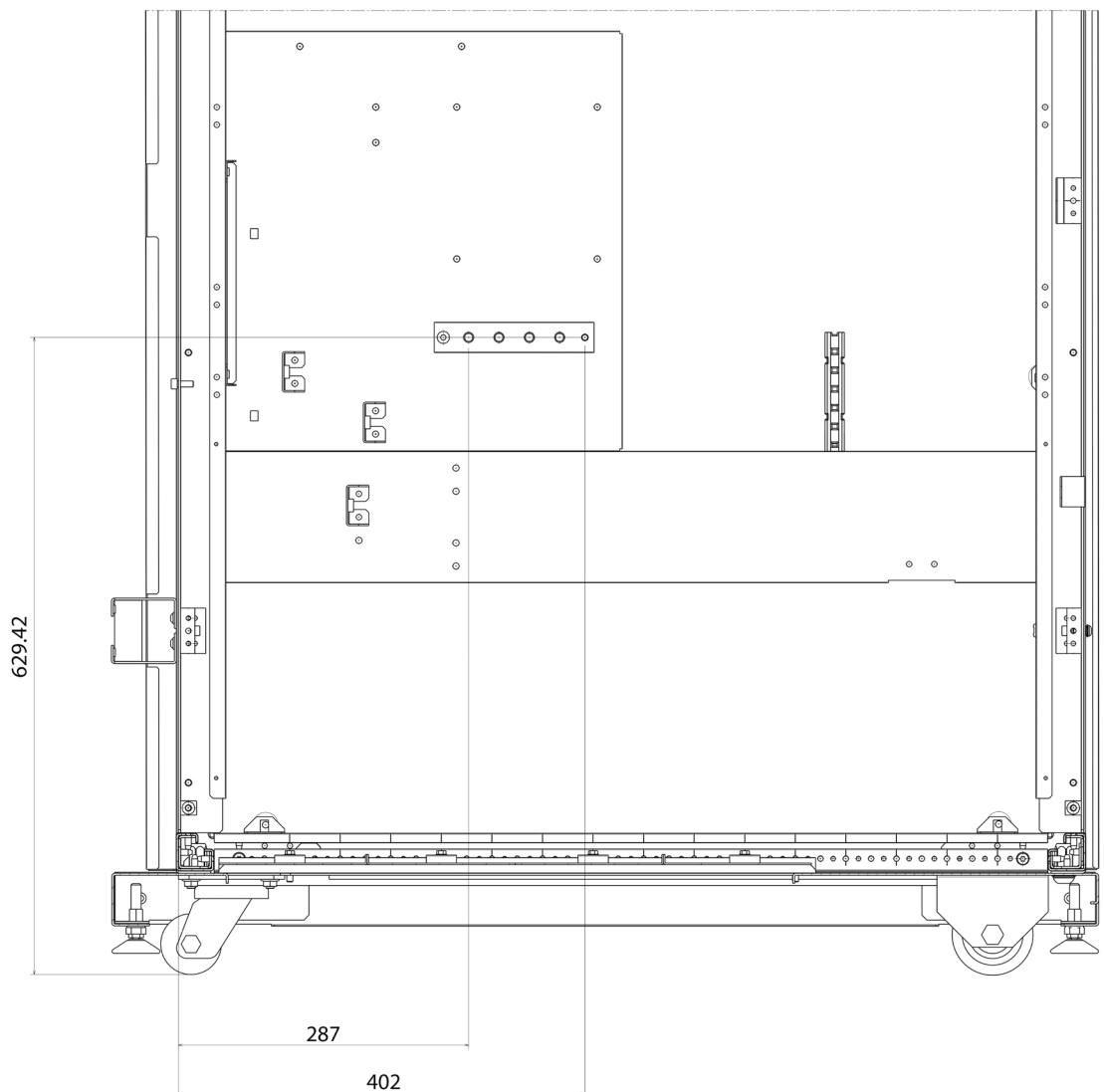
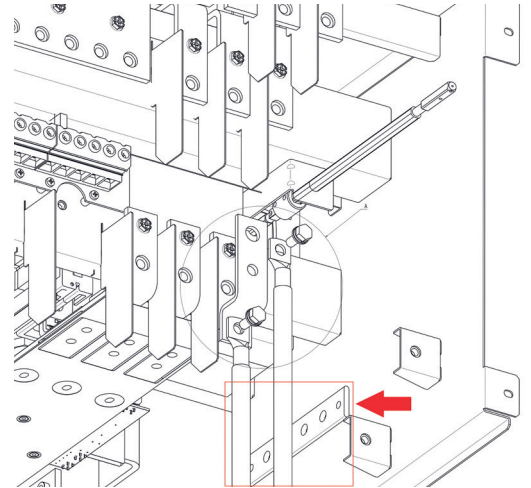
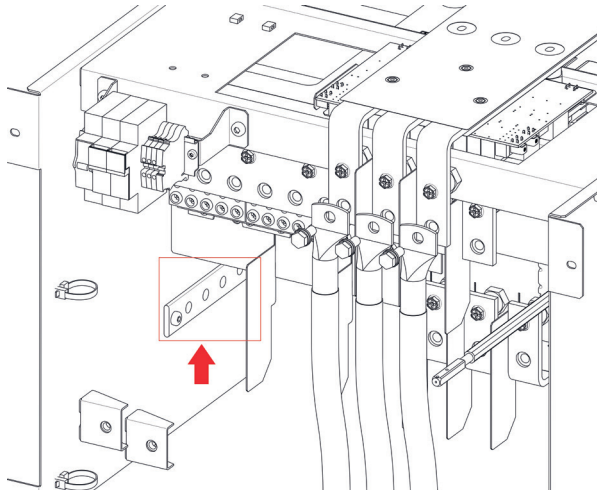

KEOR MOD 250 – earthing bars

4.2.4 Cable fastening

In the accessory box there are two metal bars for Keor MOD 125 and three metal bars for Keor MOD 250. They are used along with the plastic supports for cable ties to fasten the installation cables. Each bar must be fixed to the cabinet using two hex M8x14 screws. The plastic supports for the cable ties must be fixed on the bar using the M6 torx pan head screws.

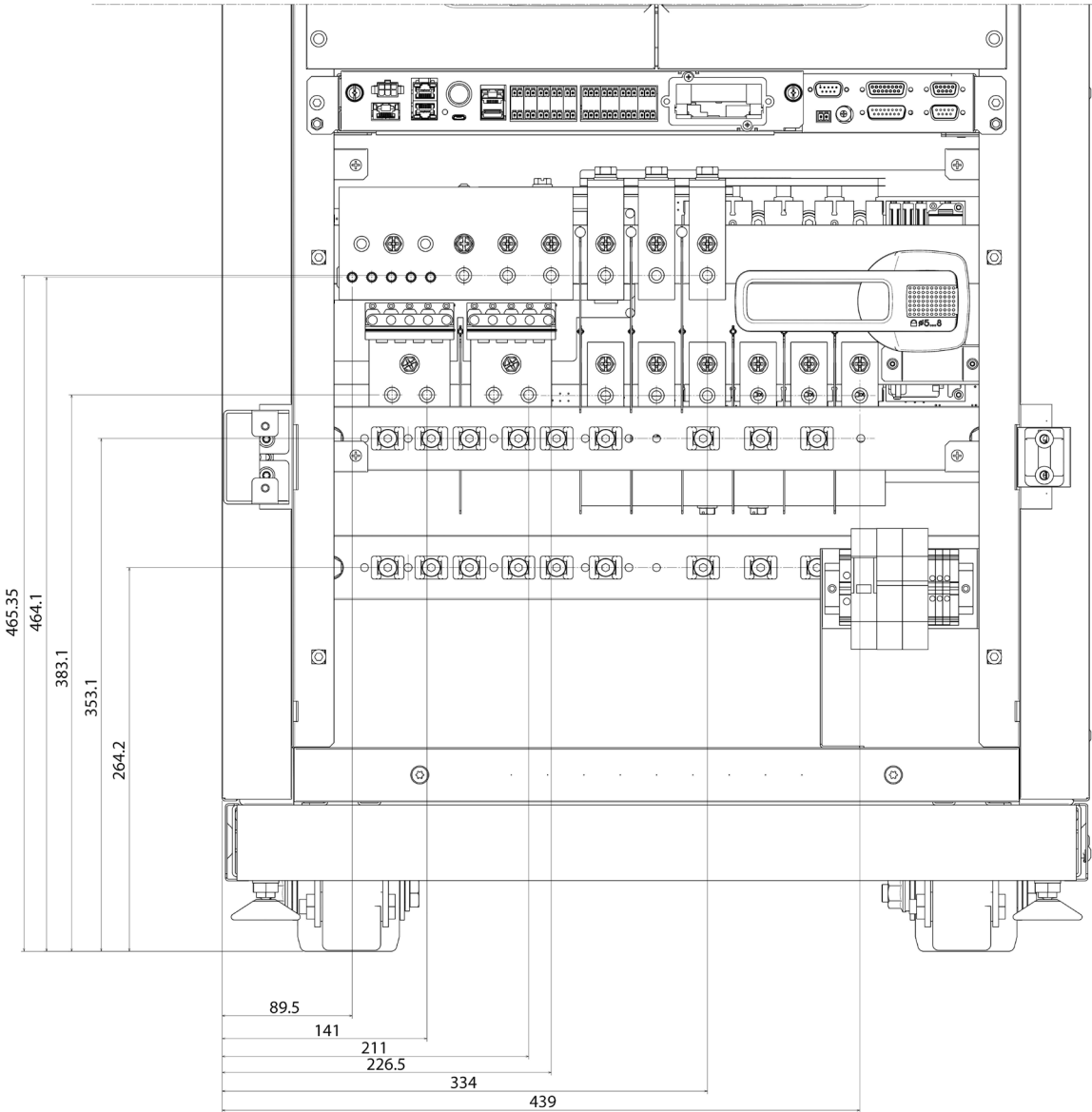

(all the dimensions are in mm)

KEOR MOD 125 – view of the two metal bars for cable fastening

4. Installation

The fastening of the battery, input and output cables on Keor MOD 125 must be done according to the following steps:

- 1) Fix the first metal bar to the cabinet, behind the surge arrester and the fuse holders, using two hex M8x14 screws.

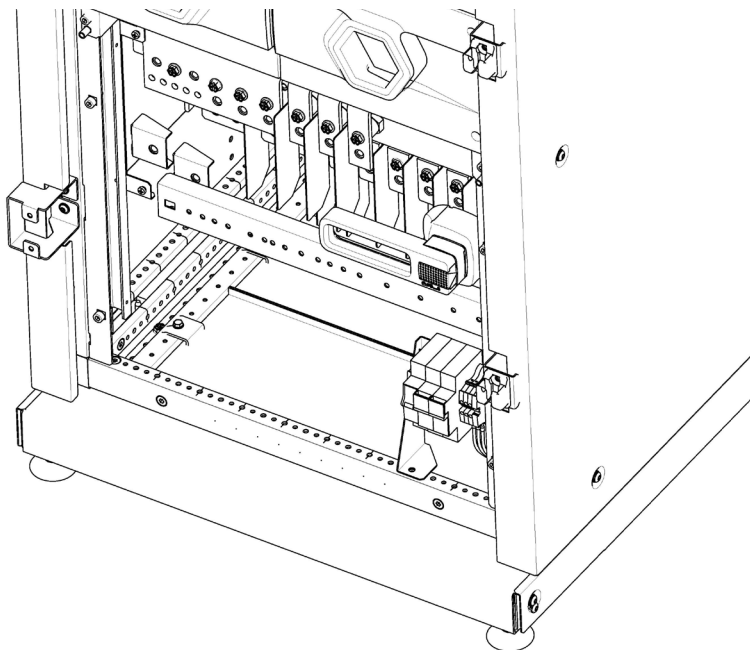

- 2) Fix the plastic supports for cable ties using M6 torx pan head screws.

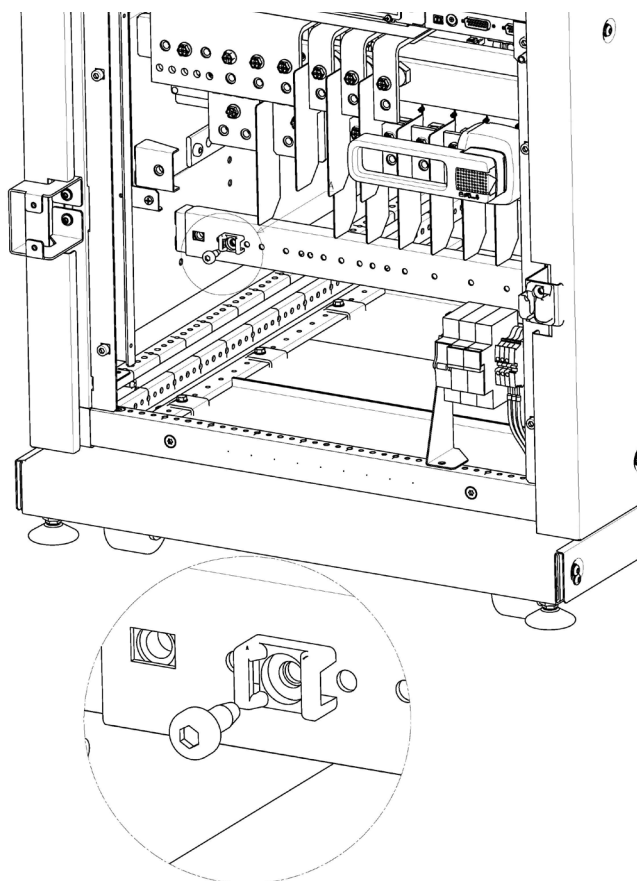

3) Fix the cables with cable ties.

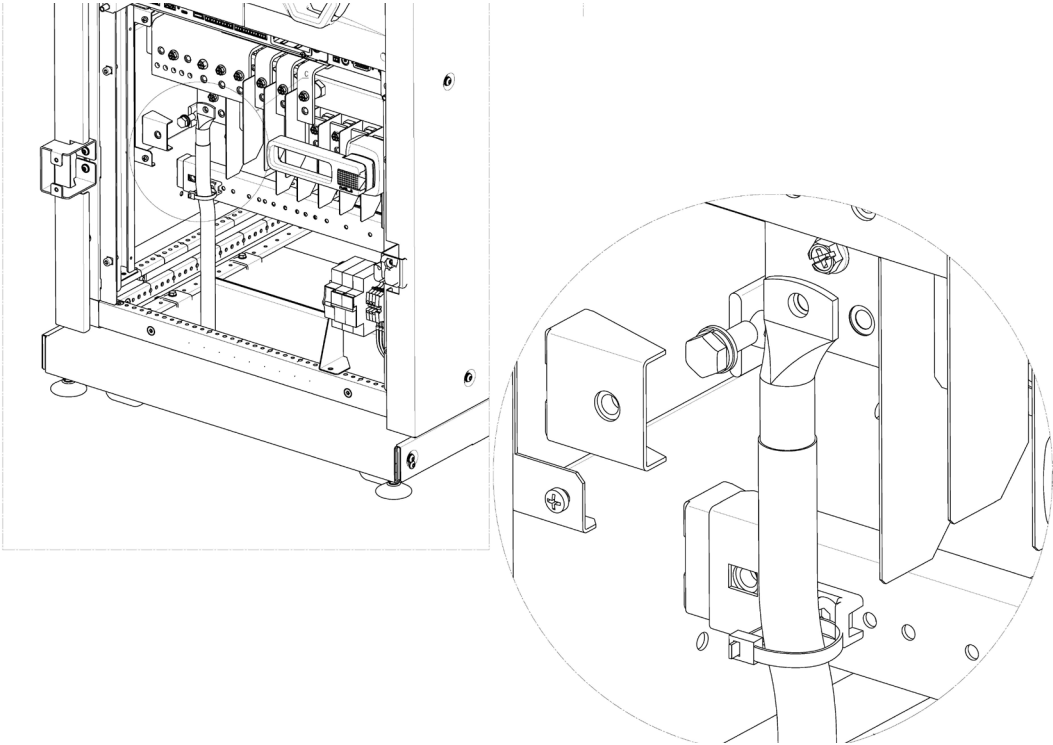

The fastening of the neutral and output cables on Keor MOD 125 must be done according to the following steps:

1) Fix the second metal bar to the cabinet, close to the maintenance manual bypass switch, using two hex M8x14 screws.

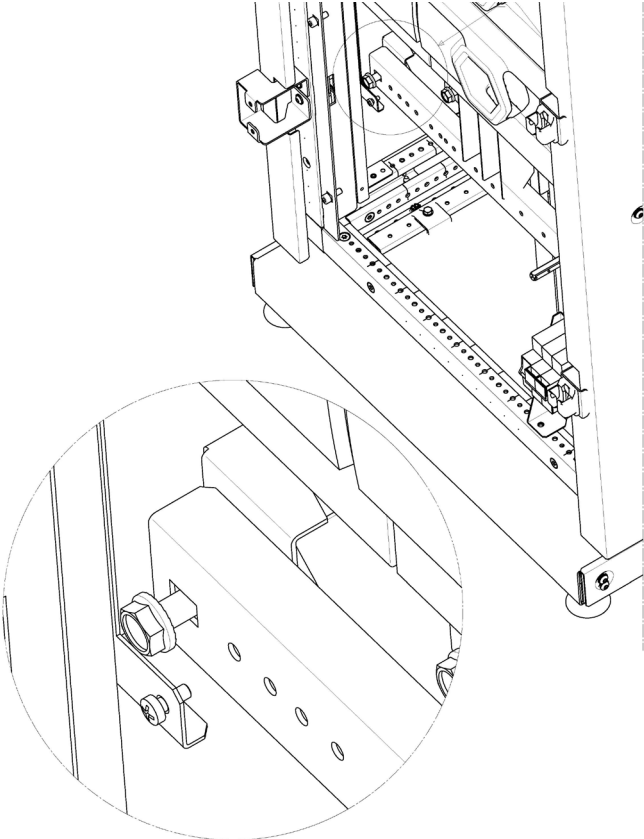

4. Installation

- 2) Fix the plastic support for cable ties using M6 torx pan head screws.

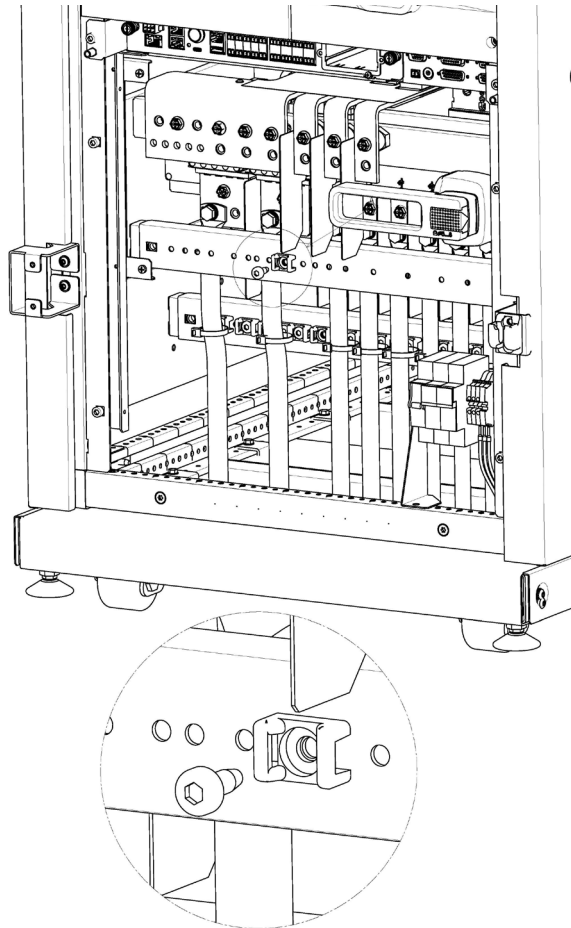

- 3) Fix the cables with cable ties.

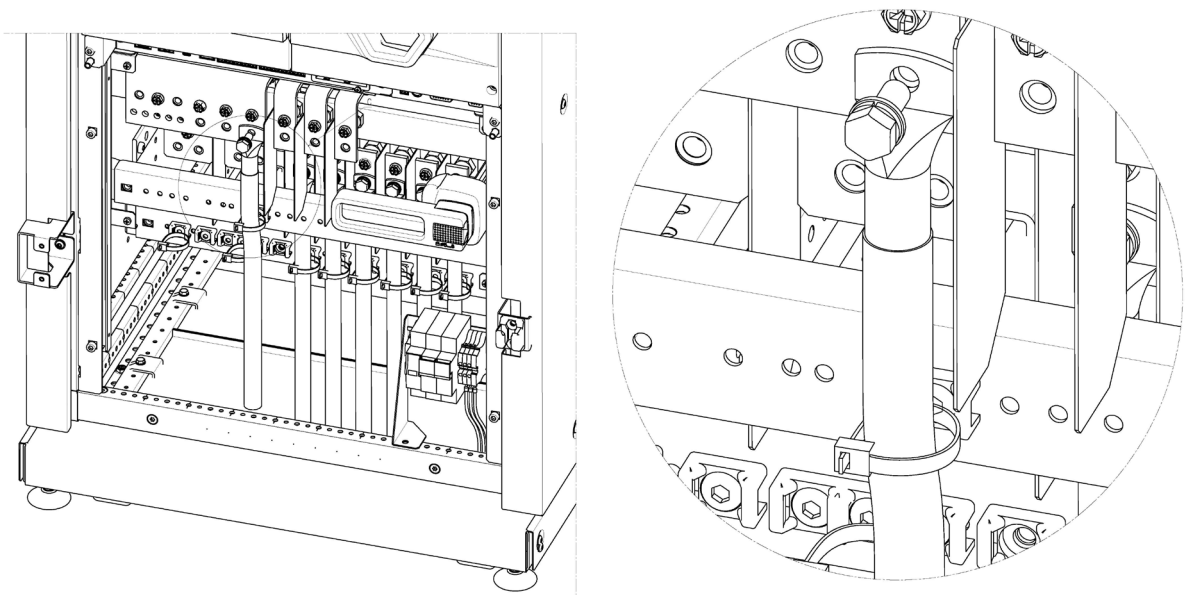

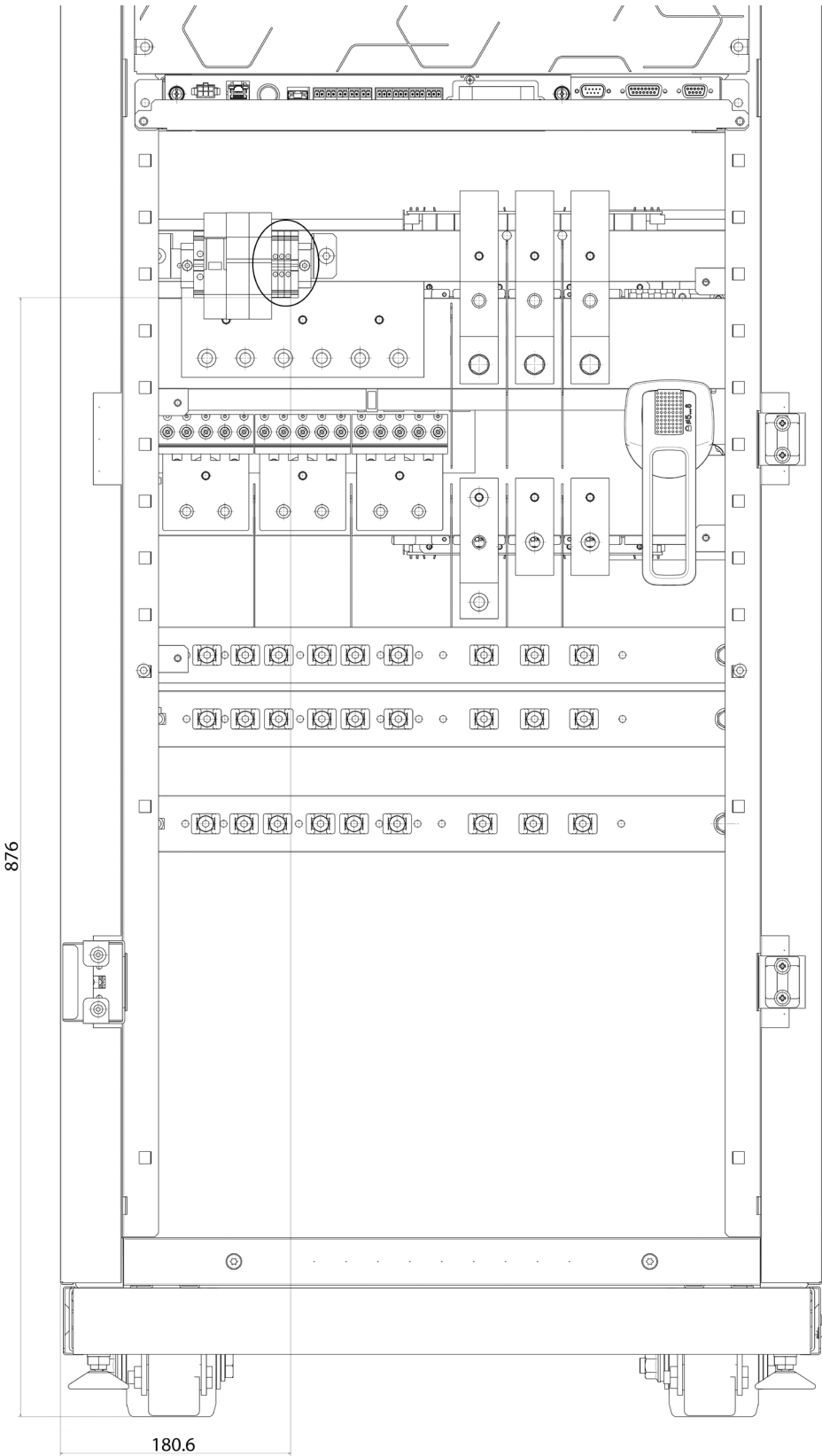

(all the dimensions are in mm)

KEOR MOD 250 – view of the three metal bars for cable fastening

4. Installation

The fastening of the battery and output cables on Keor MOD 250 must be done according to the following steps:

- 1) Fix the first metal bar at the bottom of the cabinet using two hex M8x14 screws. Then fix the plastic support for the cable ties using M6 torx pan head screws.

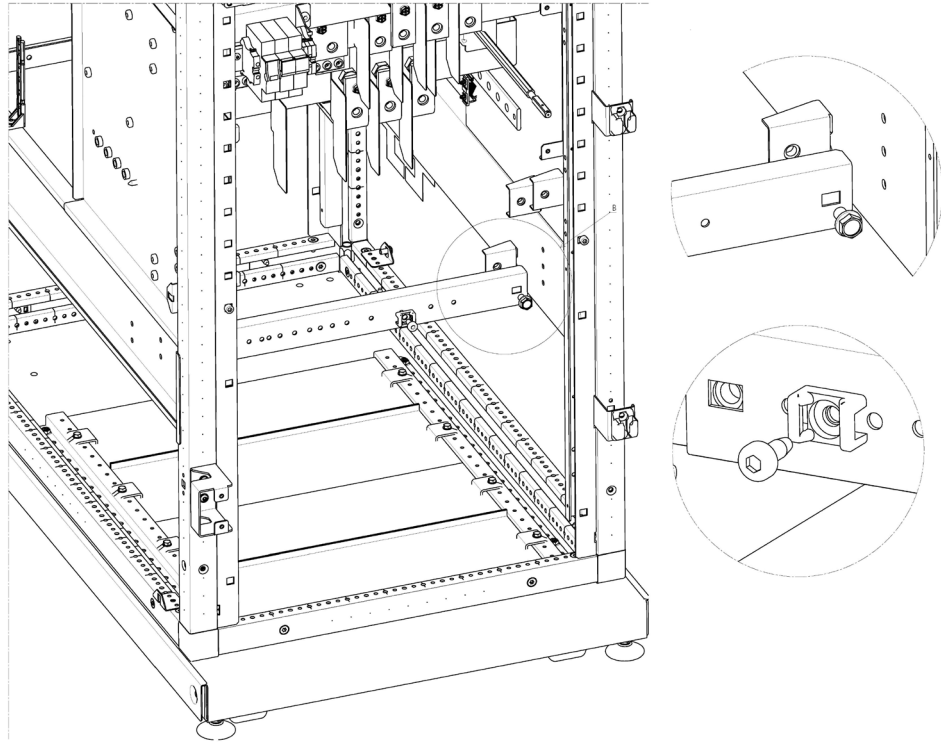

- 2) Fix the cable with cable ties.

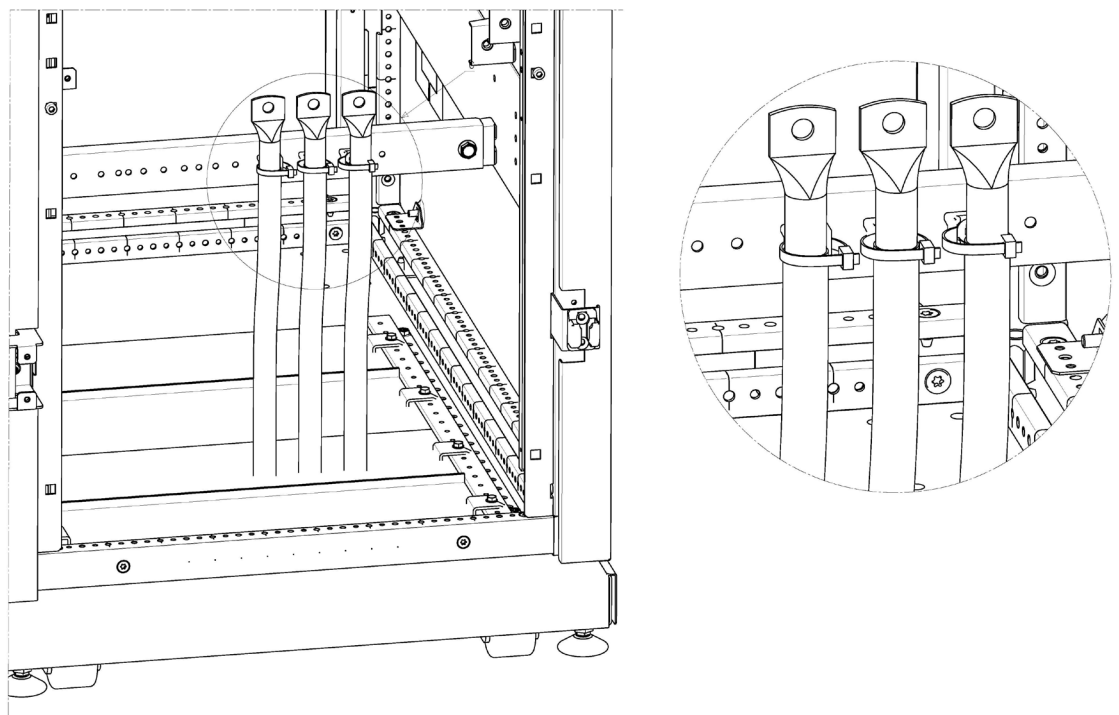

The fastening of the neutral and bypass cables on Keor MOD 250 must be done according to the following steps:
1) Fix the second metal bar above the first bar using two hex M8x14 screws. Then fix the plastic support for the cable ties using M6 torx pan head screws.

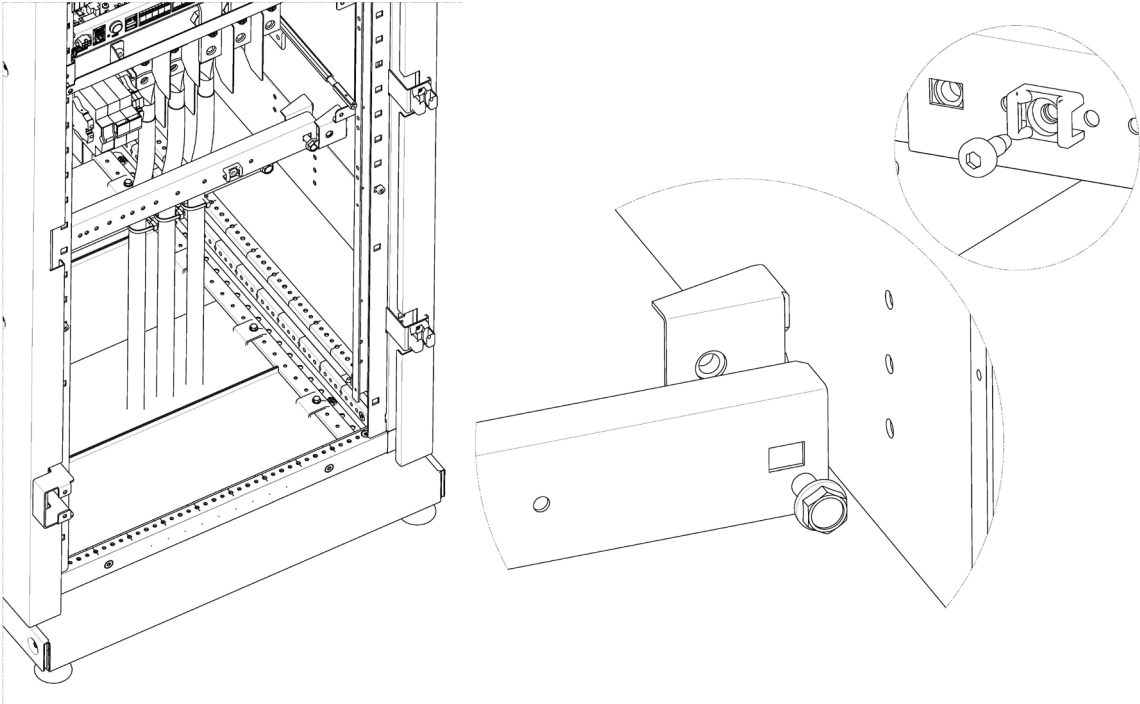

2) Fix the cable with cable ties.

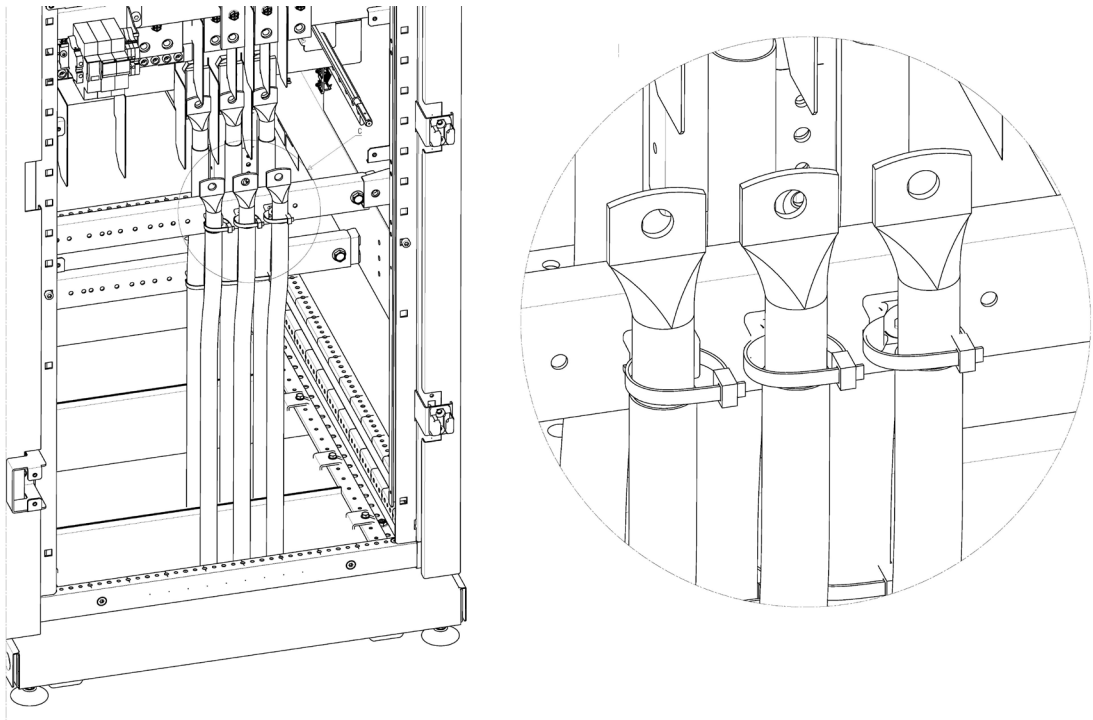

4. Installation

The fastening of the input cables on Keor MOD 250 must be done according to the following steps:

- 1) Fix the third metal bar above the second bar using two hex M8x14 screws. Then fix the plastic support for the cable ties using M6 torx pan head screws.

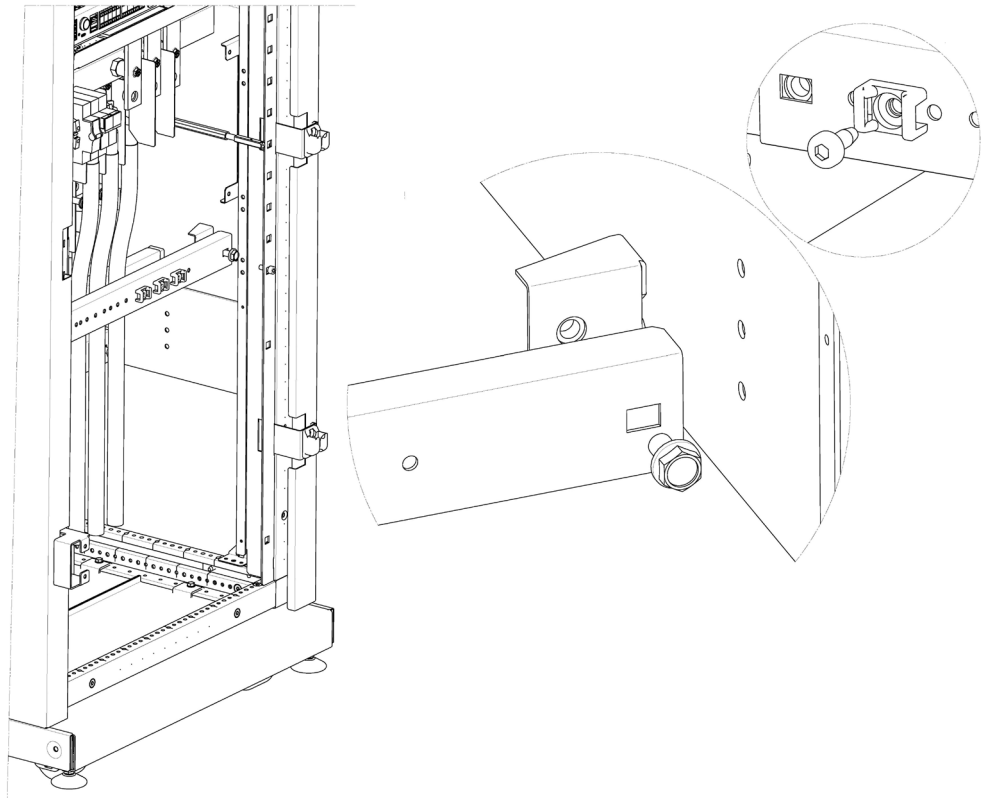

- 2) Fix the cable with cable ties.

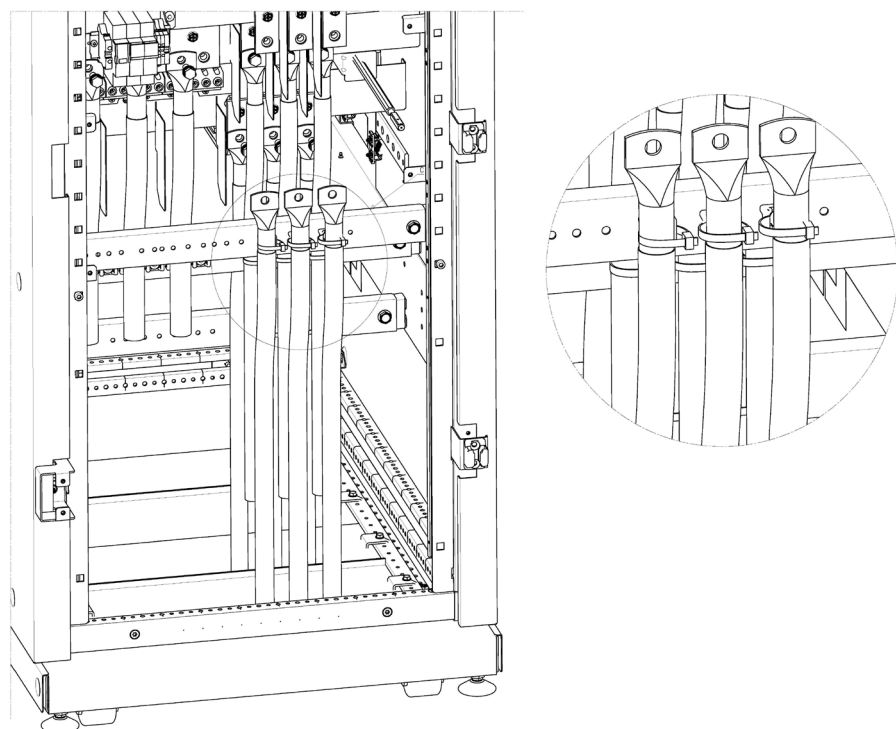

The tightening torque values for the cables are the following:

- M8 screws: 24 Nm
- M6 nuts: 15 Nm
- M10 nuts: 35 Nm

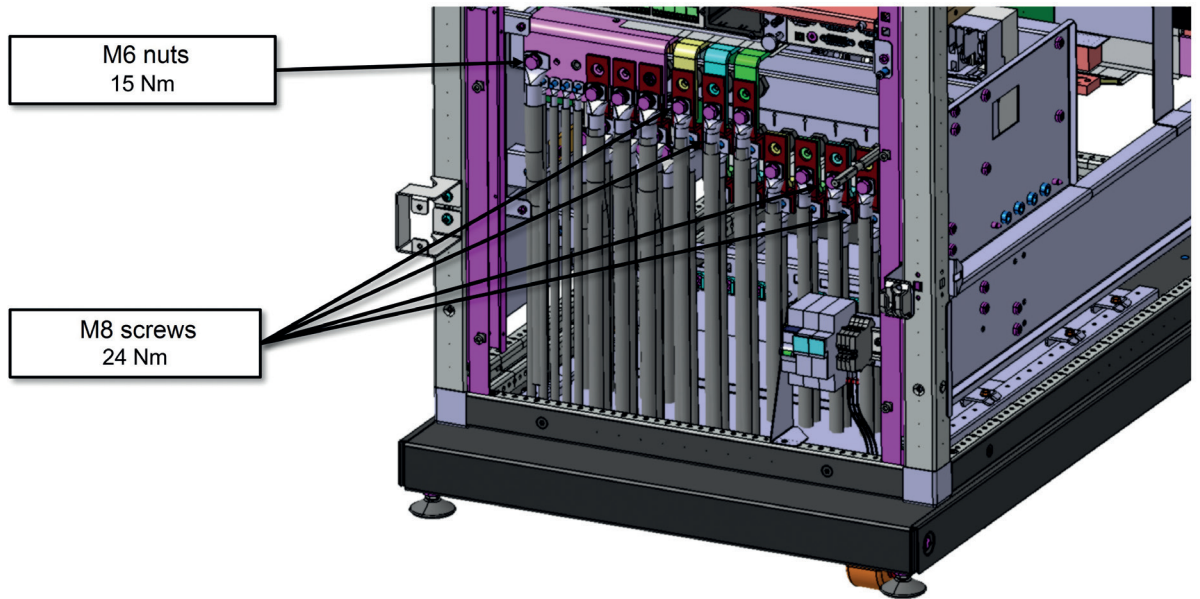

KEOR MOD 125

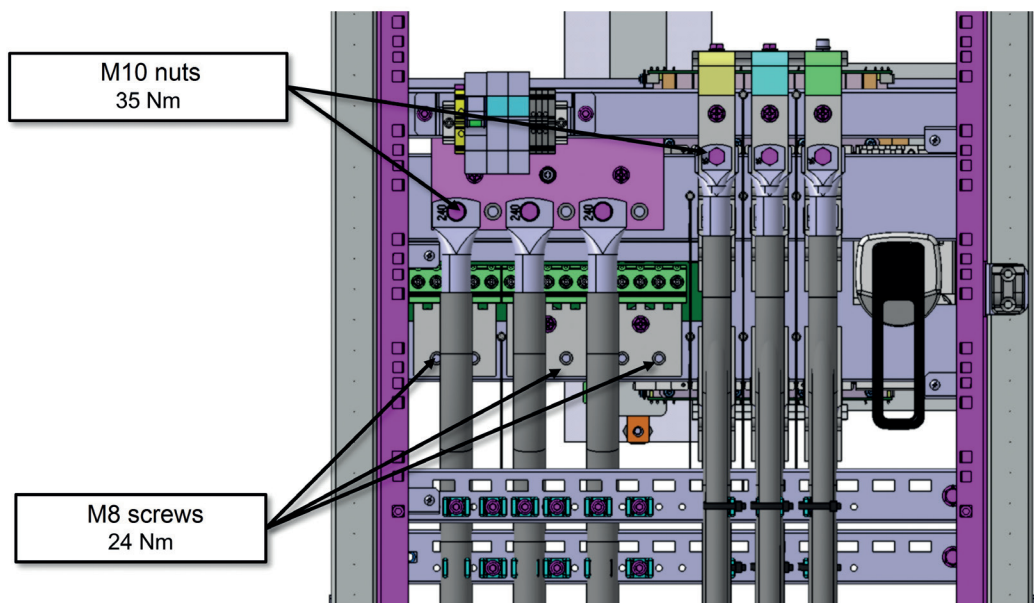

KEOR MOD 250

4. Installation

4.2.5 Backfeed protection

An external protection against voltage backfeed must be provided according to the following diagrams:

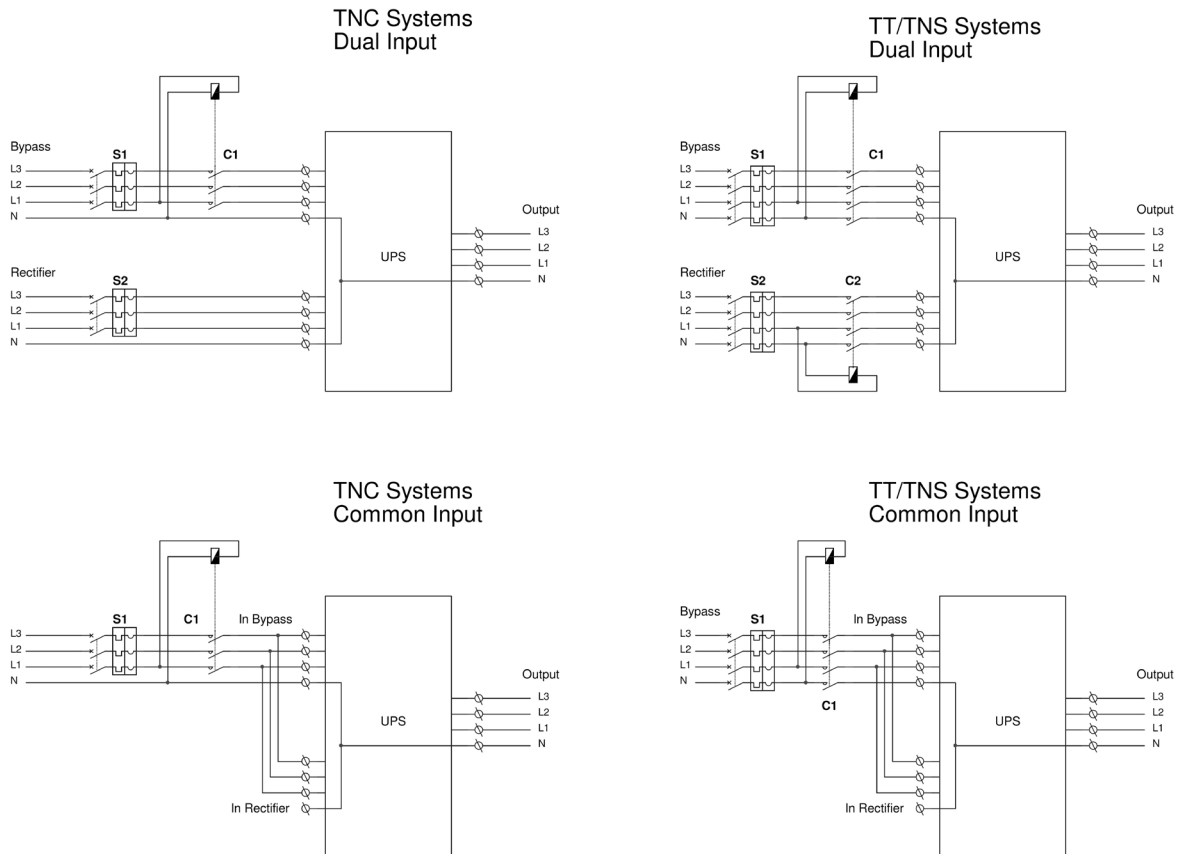

INDICATION

The following information related to the auxiliary contact for the backfeed protection are not yet implemented.

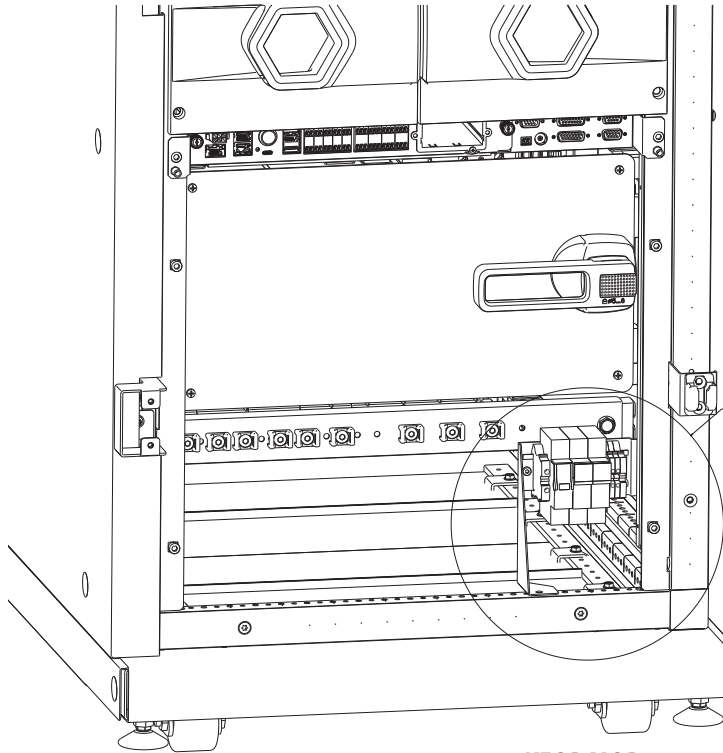

KEOR MOD 125

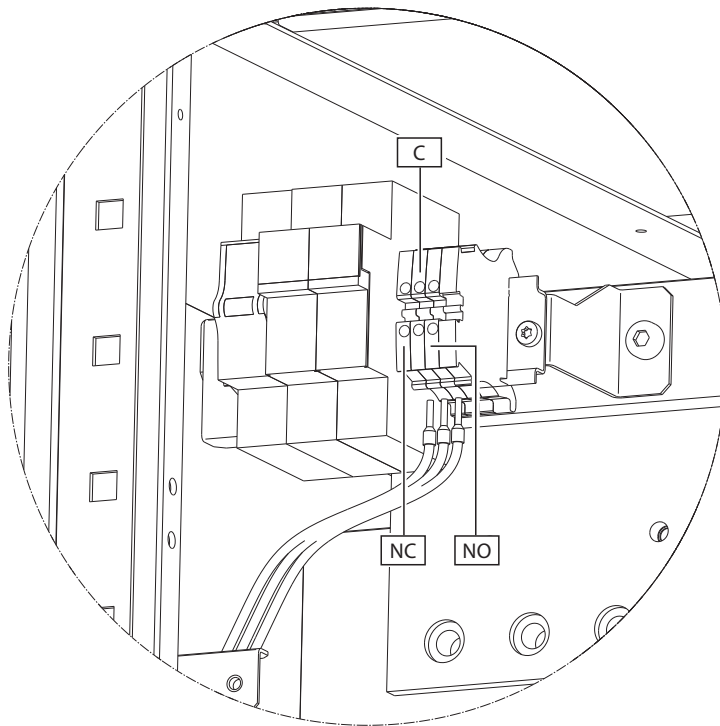
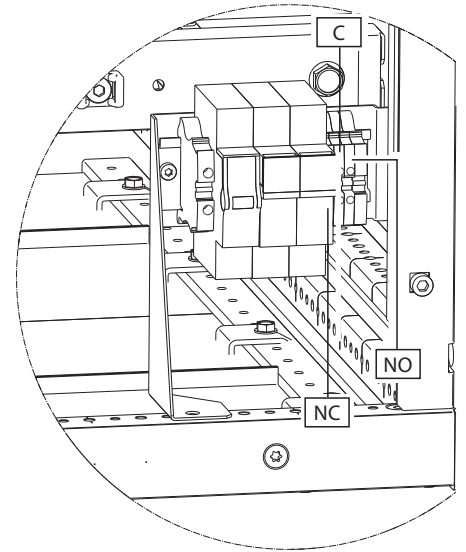

KEOR MOD 250

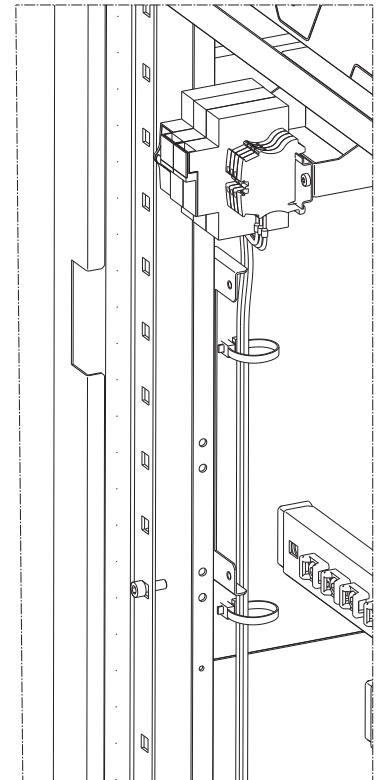

The UPS has an auxiliary contact for the actuation of the external backfeed protection (protection against power transfer towards the input). This auxiliary contact has been created with a C/NC/NO relay and is available in the DIN rail inside the cabinet.

4. Installation

If the UPS detects a voltage backfeed, the relay is energized and changes status, enabling the external disconnection of the input lines as indicated in the diagrams shown below.

The relay contacts characteristics are :

- Maximum applicable voltage: 250Vac.
- Maximum applicable current: 6A

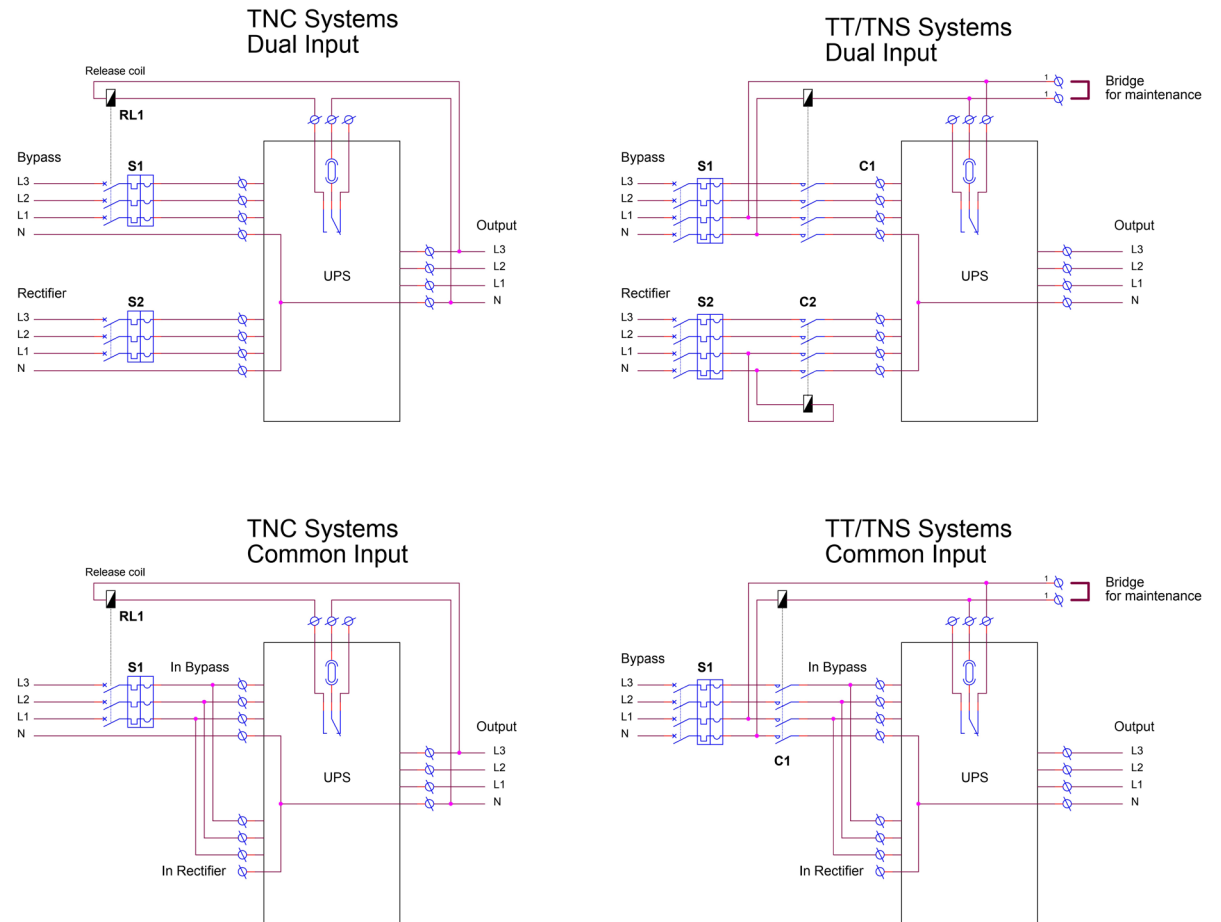

INDICATION

If during operation, the UPS signals that the backfeed protection has been actuated, contact the LEGRAND Technical Support Service.

4.2.6 External battery cabinets installation

The installation of external battery cabinets is necessary in case of UPS without internal batteries. For UPS with internal batteries, it can increase the runtime in stored energy mode.

The external battery cabinets available are:

- a modular cabinet (3 104 84) using up to 16 battery drawers.
- those indicated in table 6 of chapter 11 which are compact, non-modular cabinets that use a shelf architecture.

It is possible to install up to two external battery cabinet directly to the UPS Keor MOD. Avoid bridge connections when connecting the battery cabinets to the UPS.

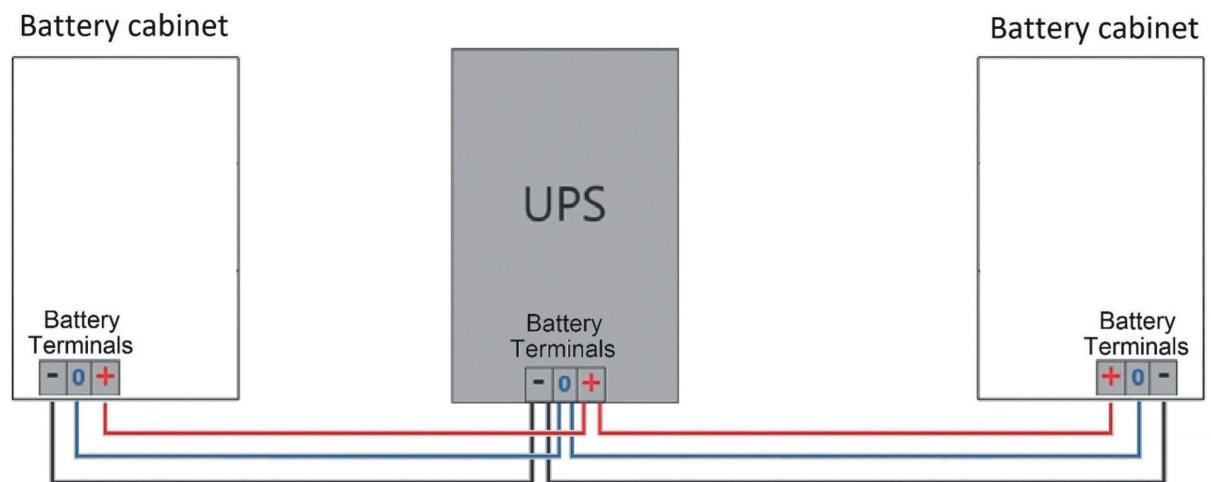

When there are more than two battery cabinets, it is recommended to provide a battery switchboard.

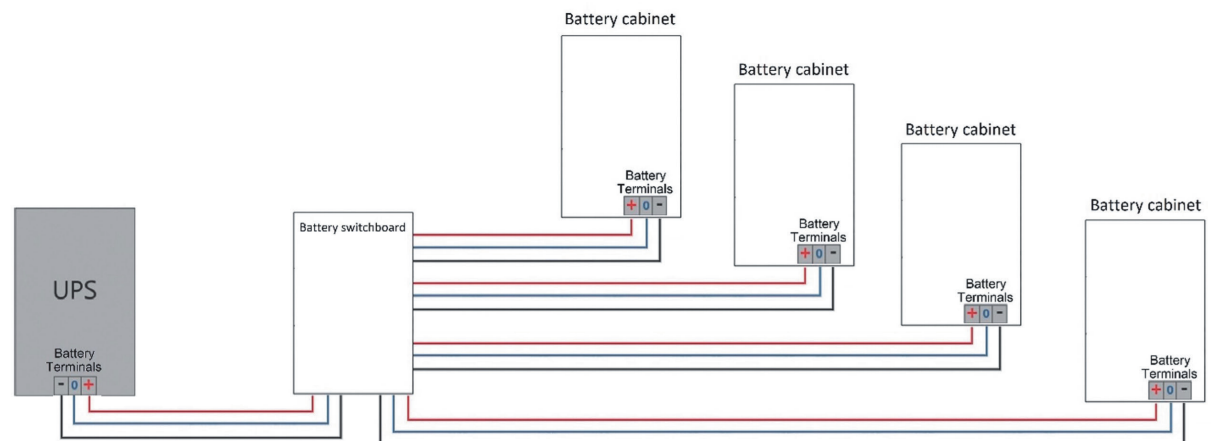

DANGER

Different connection solutions are the sole responsibility of the installer.

The implementation of the battery switchboard must be carried out according to the local installation regulations and it is a responsibility of the installer.

The external modular battery cabinets must be homogeneous in the number of battery drawers. The difference between one cabinet and the other must be a maximum of 1 KB (2 battery drawers).

INDICATION

There must be at least 1 KB (Battery Kit) every 25 kVA of nominal UPS power. For internal battery drawers and for external modular battery cabinets, 1 KB is made up of 2 battery drawers.

Table 5 of chapter 11 indicates the recommended cables and fuses to connect the UPS to the battery switchboard.

The input current and the output power of the UPS are indicated in chapter 11 and the battery current in table 5 of chapter 11.

Tables 6 of chapter 11 provides information about the fuses to be installed for the external non-modular battery cabinets.

4. Installation

4.2.7 Input cables installation

The default configuration has the input line in common with the bypass line through a metal jumper.

Before the installation of the input cables, check the following:

- the mains line must be able to provide an input voltage of 400 V + 15% - 20%;
- the available mains power must be at least the same of the UPS nominal power;
- the cables to connect to the UPS must be isolated upstream and no voltage must be present;
- the earthing cable from the low voltage switchgear must be properly connected (see paragraph 4.2.3).



WARNING

The neutral input cable must always be connected.

KEOR MOD 125

The default configuration has the input line in common with the bypass line through a metal jumper.

If no change is required, follow these steps:

- unscrew the three hex M8x25 screws that fix the jumper to the bypass terminal of the busbar;
- crimp the input and neutral cables with M8 eyelets;
- connect the input cables L1, L2, L3 to the metal jumper of the terminals **BYP L1**, **BYP L2**, **BYP L3** of the bypass busbar using the three screws removed previously along with M8 flat washers and M8 grower washers. The grower washer must always be put on top of the flat washer;
- do not change the phase sequence (L1, L2, L3);
- connect the input neutral cable to the neutral busbar with a hex M8x20 screw along with a M8 flat washer and a M8 grower washer. The grower washer must always be put on top of the flat washer.

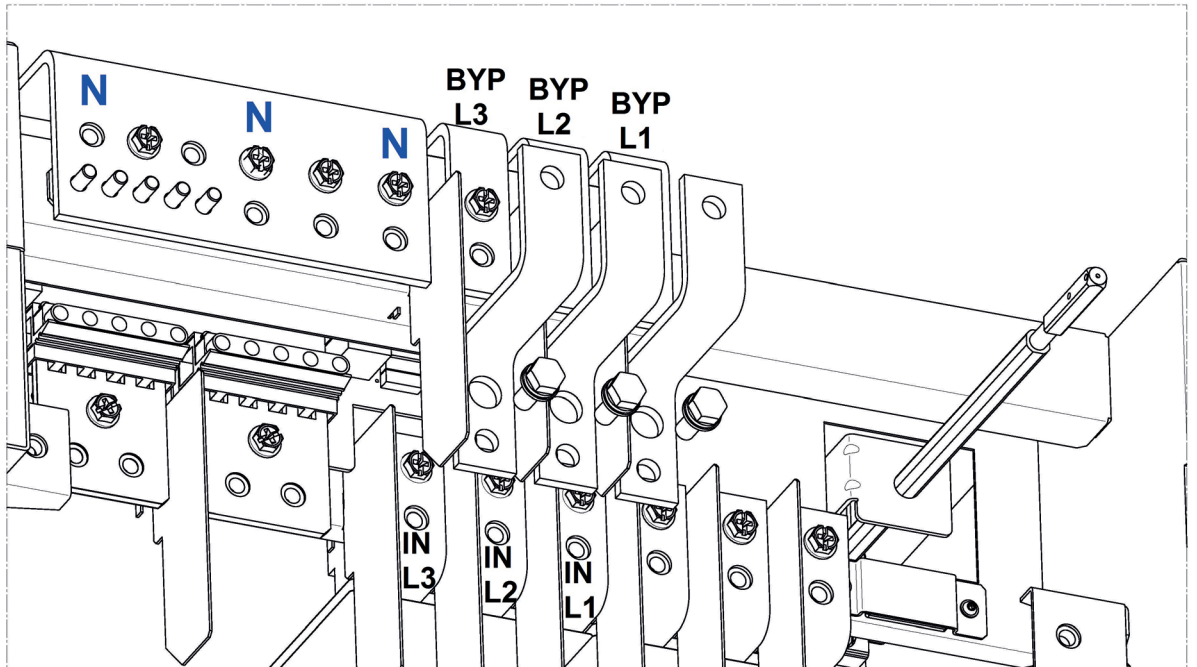

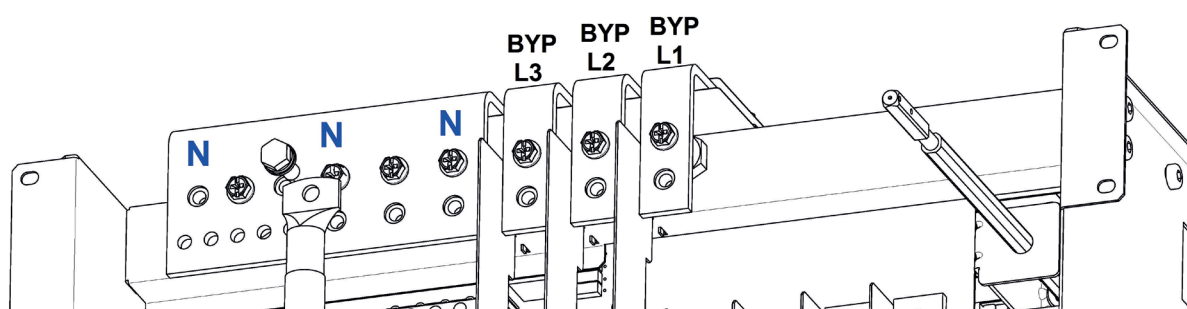
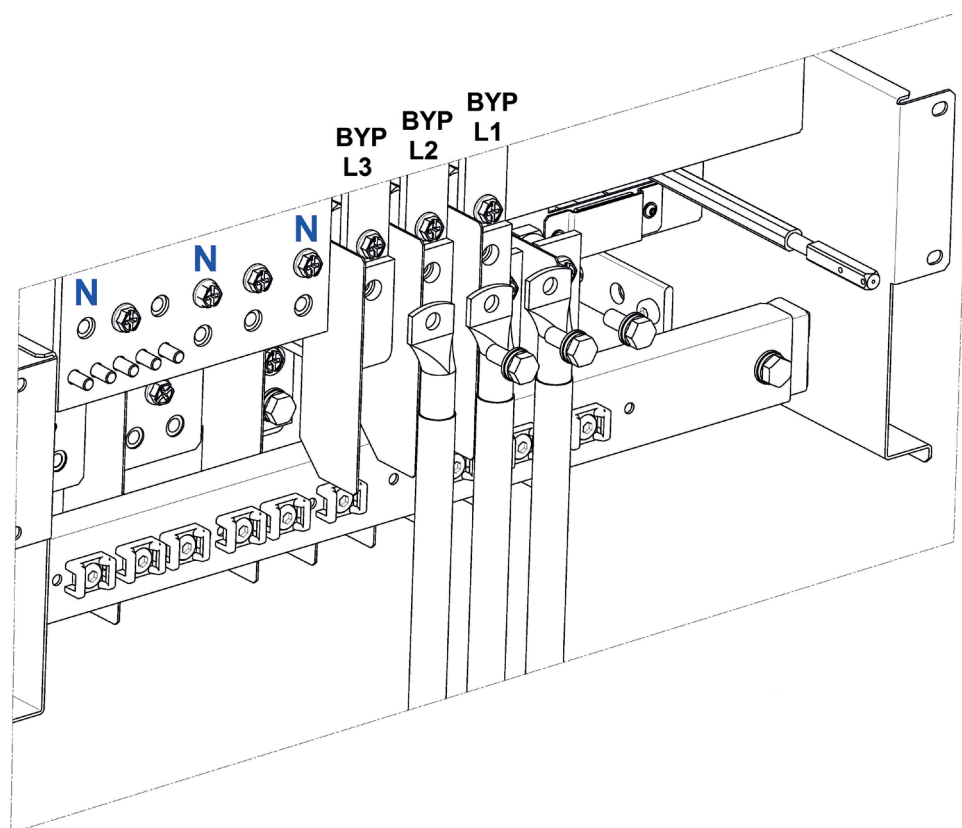

KEOR MOD 125 – input cables installation with input line in common with bypass line

In case the input line is separated from the bypass line, follow these steps:

- remove the metal jumper that connects the input line with the bypass line;
- crimp the input and neutral cables with M8 eyelets;
- connect the input cables L1, L2, L3 to the terminals IN L1, IN L2, IN L3 of the input busbar using three hex M8x20 screws along with M8 flat washers and M8 grower washers. The grower washer must always be put on top of the flat washer;
- do not change the phase sequence (L1, L2, L3);
- connect the input neutral cable to the neutral busbar with a hex M8x20 screw along with a M8 flat washer and a M8 grower washer. The grower washer must always be put on top of the flat washer.

4. Installation

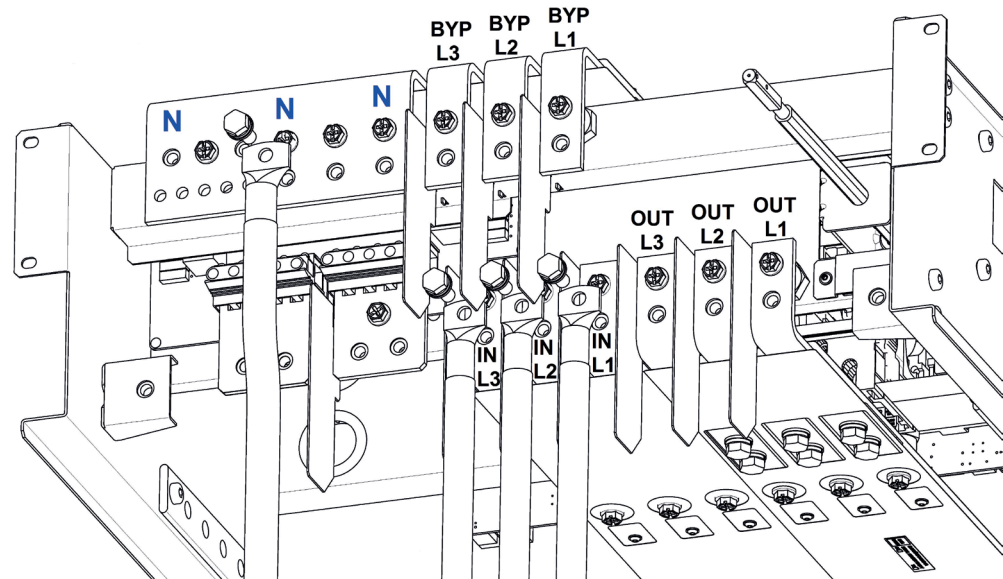

KEOR MOD 125 – input cables installation with input line separated from the bypass line

When the input line is separated from the bypass line, it is also possible to install an accessory for double cable. In this way it is possible for each terminal to use two cables with a smaller cross section than the one of a single cable.

For this installation, follow these steps:

- remove the metal jumper that connects the input line with the bypass line;
- crimp the input and neutral cables with M8 eyelets;
- connect the first three input cables L1, L2, L3 to the hole at the bottom of the accessory for double cable using three hex M8x20 screws along with M8 flat washers and M8 grower washers. The grower washer must always be put on top of the flat washer;
- connect the other three input cables L1, L2, L3 to the hole at the top of the accessory for double cable using three hex M8x25 screws along with M8 flat washers and M8 grower washers. Through these screws, fix the accessories to the terminals IN L1, IN L2, IN L3 of the input busbar. The grower washer must always be put on top of the flat washer;
- do not change the phase sequence (L1, L2, L3);
- connect the first neutral cable to the hole at the bottom of the accessory for double cable using a hex M8x20 screw along with a M8 flat washer and a M8 grower washer. The grower washer must always be put on top of the flat washer;
- connect the second neutral cable to the hole at the top of the accessory for double cable using a hex M8x25 screw along with M8 flat washer and M8 grower washer. Through this screw, fix the accessory to the terminal of the neutral busbar. The grower washer must always be put on top of the flat washer.

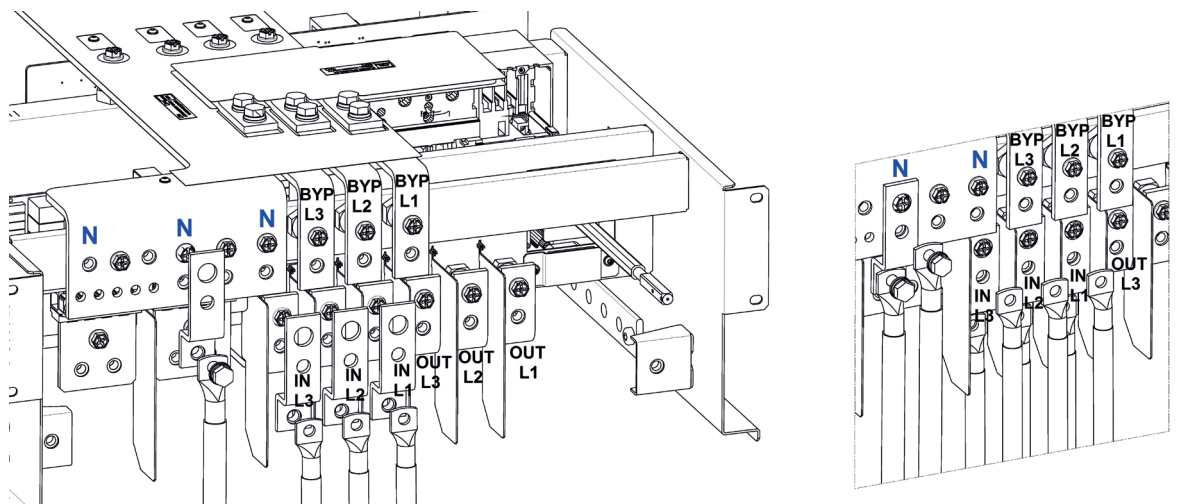

KEOR MOD 125 – input cables installation with accessories for double cable and input line separated from the bypass line

KEOR MOD 250

The default configuration has the input line in common with the bypass line through a metal jumper. If no change is required, follow these steps:

- unscrew the three hex M10x35 screws that fix the jumper to the input terminal of the busbar;
- crimp the input and neutral cables with M10 eyelets;
- connect the input cables L1, L2, L3 to the metal jumper of the terminals IN L1, IN L2, IN L3 of the input busbar using the three screws removed previously along with M10 flat washers and M10 grower washers. The grower washer must always be put on top of the flat washer;
- do not change the phase sequence (L1, L2, L3);
- connect the input neutral cable to the neutral busbar with a hex M10x30 screw along with a M10 flat washer and a M10 grower washer. The grower washer must always be put on top of the flat washer.

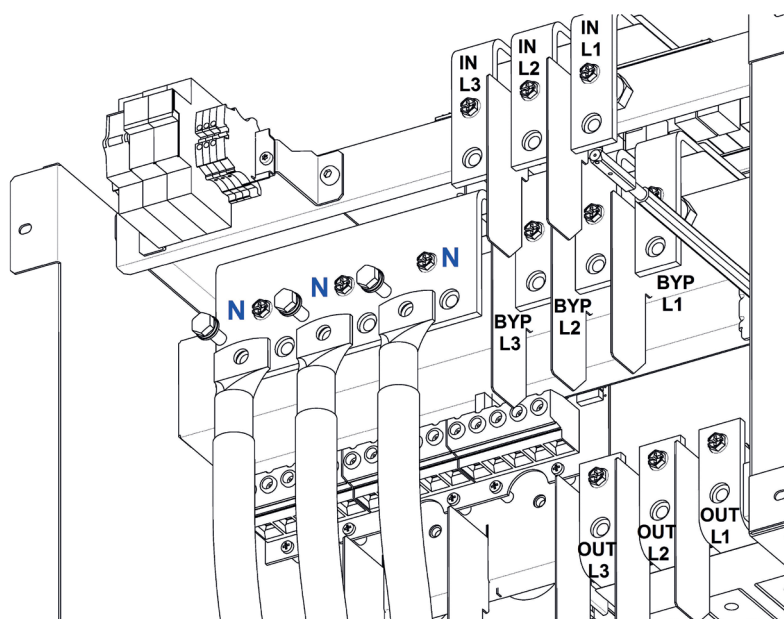
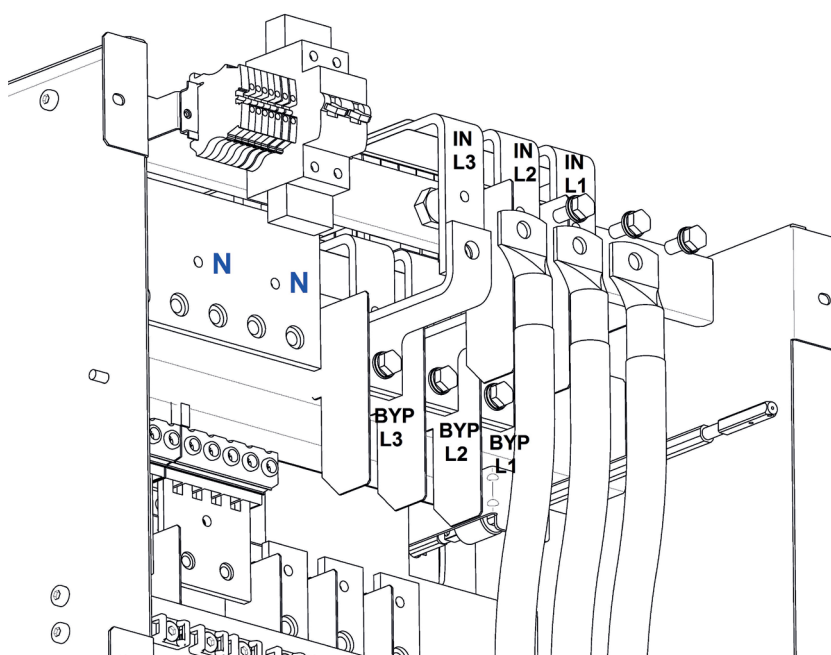

KEOR MOD 250 – input cables installation with input line in common with bypass line

4. Installation

In case the input line is separated from the bypass line, follow these steps:

- remove the metal jumper that connects the input line with the bypass line;
- crimp the input and neutral cables with M10 eyelets;
- connect the input cables L1, L2, L3 to the terminals IN L1, IN L2, IN L3 of the input busbar using three hex M10x30 screws along with M10 flat washers and M10 grower washers. The grower washer must always be put on top of the flat washer;
- do not change the phase sequence (L1, L2, L3);
- connect the input neutral cable to the neutral busbar with a hex M10x30 screw along with a M10 flat washer and a M10 grower washer. The grower washer must always be put on top of the flat washer.

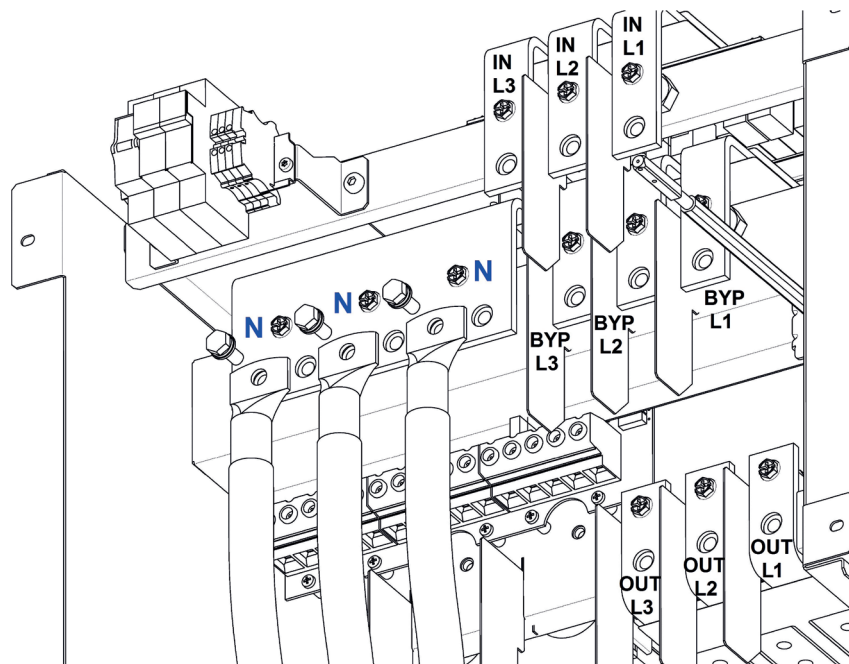
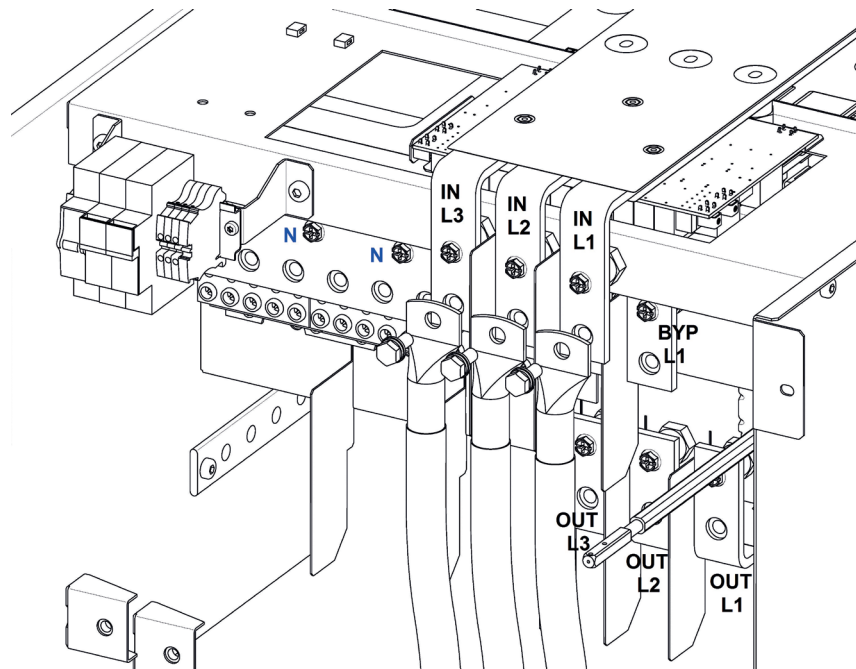

KEOR MOD 250 – input cables installation with input line separated from the bypass line

When the input line is separated from the bypass line, it is also possible to install an accessory for double cable. In this way it is possible for each terminal to use two cables with a smaller cross section than the one of a single cable.

For this installation, follow these steps:

- remove the metal jumper that connects the input line with the bypass line;
- crimp the input and neutral cables with M10 eyelets;
- connect the first three input cables L1, L2, L3 to the hole at the bottom of the accessory for double cable using three hex M10x30 screws along with M10 flat washers and M10 grower washers. The grower washer must always be put on top of the flat washer;
- connect the other three input cables L1, L2, L3 to the hole at the top of the accessory for double cable using three hex M10x35 screws along with M10 flat washers and M10 grower washers. Through these screws, fix the accessories to the terminals IN L1, IN L2, IN L3 of the input busbar. The grower washer must always be put on top of the flat washer;
- do not change the phase sequence (L1, L2, L3);
- connect the first input neutral cable to the hole at the bottom of the accessory for double cable using a hex M10x30 screw along with a M10 flat washer and a M10 grower washer. The grower washer must always be put on top of the flat washer;
- connect the second input neutral cable to the hole at the top of the accessory for double cable using a hex M10x35 screw along with M10 flat washer and M10 grower washer. Through this screw, fix the accessory to the terminal of the neutral busbar. The grower washer must always be put on top of the flat washer.

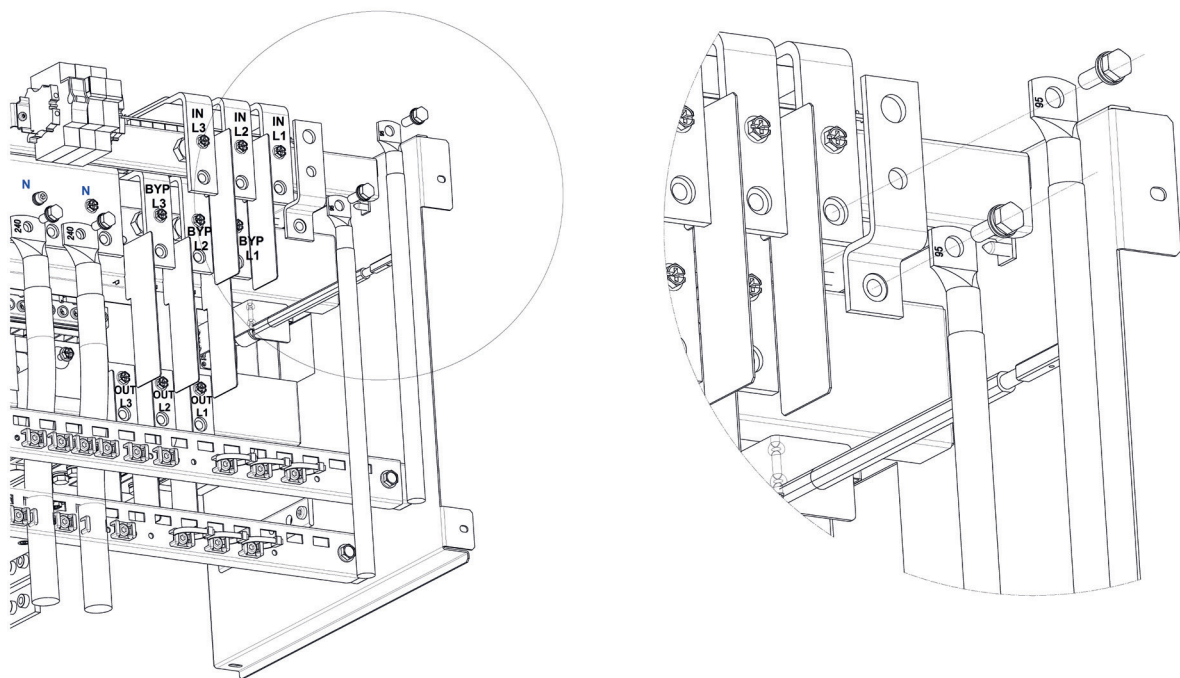

KEOR MOD 250 – input cables installation with accessories for double cable and input line separated from the bypass line

4. Installation

4.2.8 Bypass cables installation

The default configuration has the input line in common with the bypass line through a metal jumper. If no change is required, follow the steps indicated in the previous paragraph.

To perform a dual input installation with a separate bypass line, the following requirement must be met: if the two lines are supplied by the same source, the residual current breaker should be a unique one for both lines. If the two lines have a different electric potential, separate protective devices are required for each line. The UPS does not modify the neutral configuration of the system. The mains, bypass and output neutral are connected internally to each other.

Before the installation of the bypass cables, check the following:

- the bypass line must be able to provide a voltage of 400 V + 15% - 20%;
- the available bypass power must be at least the same of the UPS nominal power;
- the cables to connect to the UPS must be isolated upstream and no voltage must be present;
- the earthing cable from the low voltage switchgear must be properly connected (see paragraph 4.2.3).



WARNING

The neutral bypass cable must always be connected.

KEOR MOD 125

In case the bypass line is separated from the input line, follow these steps:

- remove the metal jumper that connects the input line with the bypass line;
- crimp the bypass and neutral cables with M8 eyelets;
- connect the bypass cables L1, L2, L3 to the terminals **BYP L1**, **BYP L2**, **BYP L3** of the bypass busbar using three hex M8x20 screws along with M8 flat washers and M8 grower washers. The grower washer must always be put on top of the flat washer;
- do not change the phase sequence (L1, L2, L3);
- connect the bypass neutral cable to the neutral busbar with a hex M8x20 screw along with a M8 flat washer and a M8 grower washer. The grower washer must always be put on top of the flat washer.

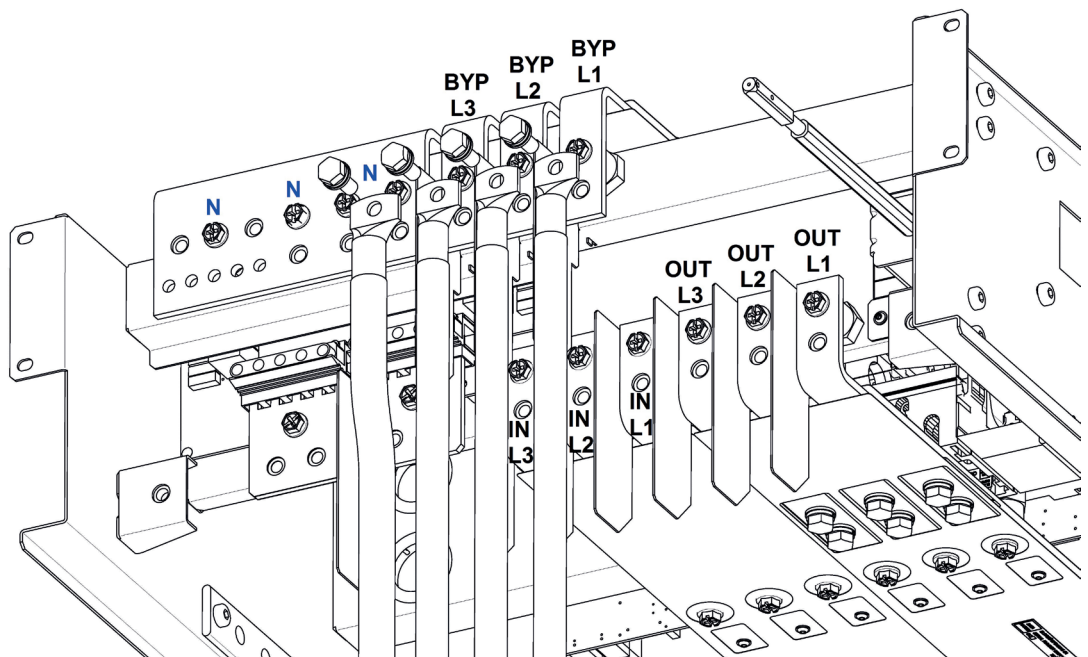

KEOR MOD 125 – bypass cables installation with input line separated from the bypass line

When the bypass line is separated from the input line, it is also possible to install an accessory for double cable. In this way it is possible for each terminal to use two cables with a smaller cross section than the one of a single cable.

For this installation, follow these steps:

- remove the metal jumper that connects the input line with the bypass line;
- crimp the bypass and neutral cables with M8 eyelets;
- connect the first three bypass cables L1, L2, L3 to the hole at the bottom of the accessory for double cable using three hex M8x20 screws along with M8 flat washers and M8 grower washers. The grower washer must always be put on top of the flat washer;
- connect the other three bypass cables L1, L2, L3 to the hole at the top of the accessory for double cable using three hex M8x25 screws along with M8 flat washers and M8 grower washers. Through these screws, fix the accessories to the terminals BYP L1, BYP L2, BYP L3 of the input busbar. The grower washer must always be put on top of the flat washer;
- do not change the phase sequence (L1, L2, L3);
- connect the first bypass neutral cable to the hole at the bottom of the accessory for double cable using a hex M8x20 screw along with a M8 flat washer and a M8 grower washer. The grower washer must always be put on top of the flat washer;
- connect the second bypass neutral cable to the hole at the top of the accessory for double cable using a hex M8x25 screw along with M8 flat washer and M8 grower washer. Through this screw, fix the accessory to the terminal of the neutral busbar. The grower washer must always be put on top of the flat washer.

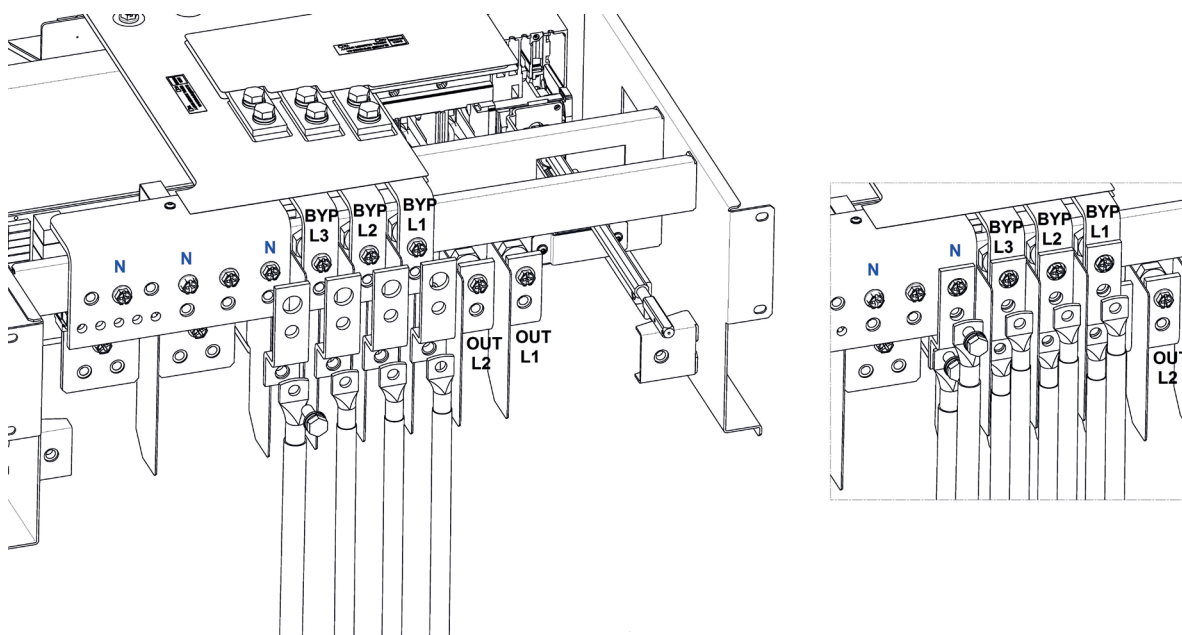

KEOR MOD 125 – bypass cables installation with accessories for double cable and input line separated from the bypass line

KEOR MOD 250

In case the bypass line is separated from the input line, follow these steps:

- remove the metal jumper that connects the input line with the bypass line;
- crimp the bypass and neutral cables with M10 eyelets;
- connect the bypass cables L1, L2, L3 to the terminals BYP L1, BYP L2, BYP L3 of the bypass busbar using three hex M10x30 screws along with M10 flat washers and M10 grower washers. The grower washer must always be put on top of the flat washer;
- do not change the phase sequence (L1, L2, L3);
- connect the bypass neutral cable to the neutral busbar with a hex M10x30 screw along with a M10 flat washer and a M10 grower washer. The grower washer must always be put on top of the flat washer.

4. Installation

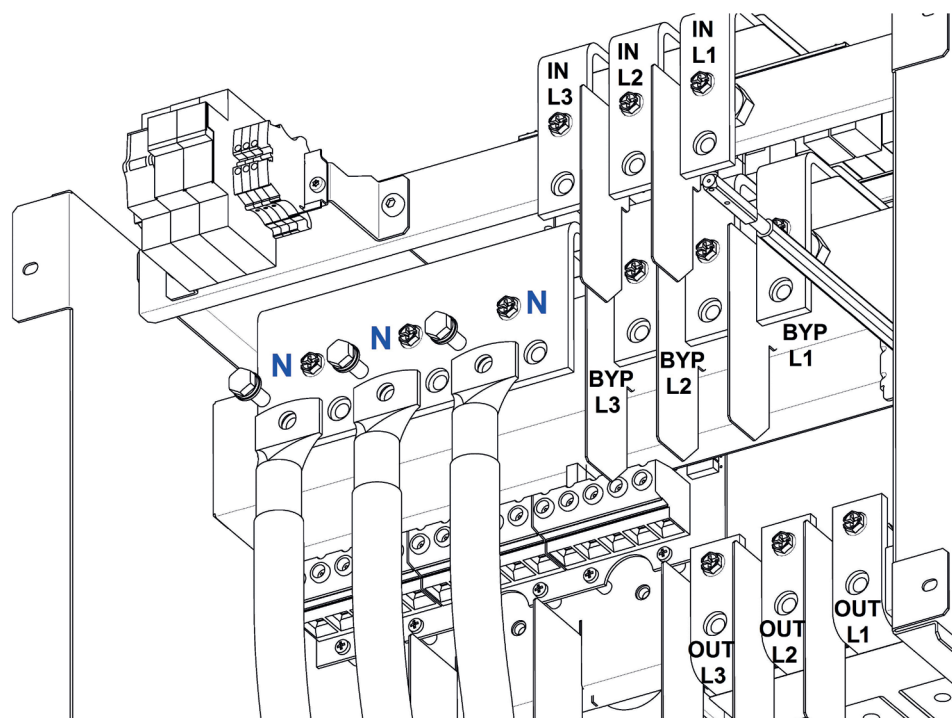
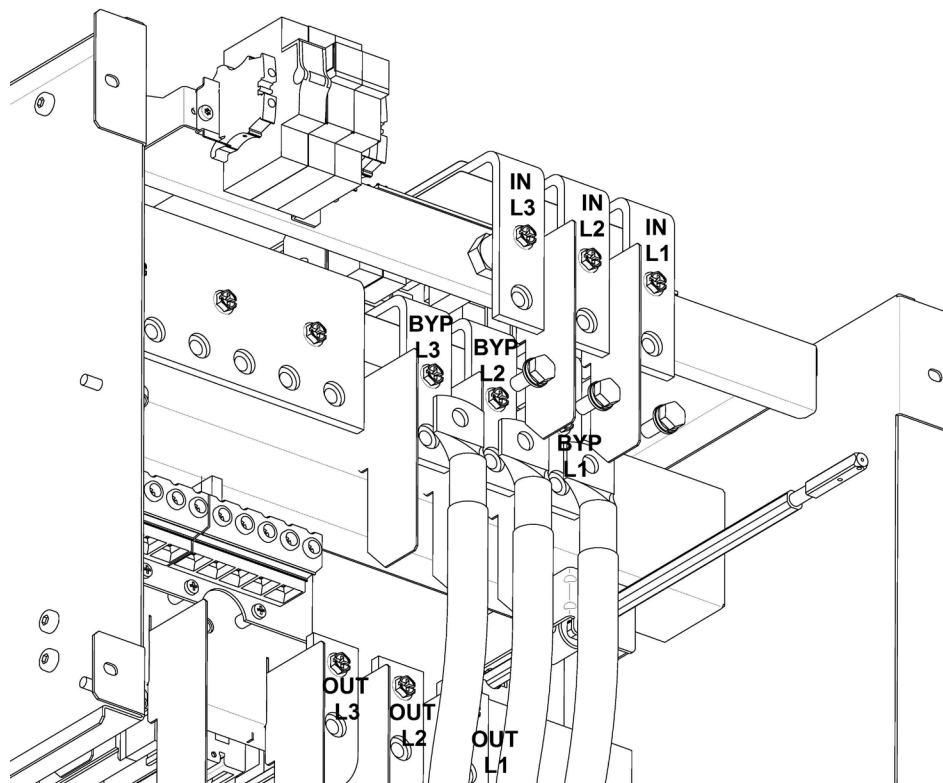

KEOR MOD 250 – bypass cables installation with input line separated from the bypass line

When the bypass line is separated from the input line, it is also possible to install an accessory for double cable. In this way it is possible for each terminal to use two cables with a smaller cross section than the one of a single cable.

For this installation, follow these steps:

- remove the metal jumper that connects the input line with the bypass line;
- crimp the bypass and neutral cables with M10 eyelets;
- connect the first three bypass cables L1, L2, L3 to the hole at the bottom of the accessory for double cable using three hex M10x30 screws along with M10 flat washers and M10 grower washers. The grower washer must always be put on top of the flat washer;
- connect the other three bypass cables L1, L2, L3 to the hole at the top of the accessory for double cable using three hex M10x35 screws along with M10 flat washers and M10 grower washers. Through these screws, fix the accessories to the terminals **BYP L1**, **BYP L2**, **BYP L3** of the bypass busbar. The grower washer must always be put on top of the flat washer;
- do not change the phase sequence (L1, L2, L3);
- connect the first bypass neutral cable to the hole at the bottom of the accessory for double cable using a hex M10x30 screw along with a M10 flat washer and a M10 grower washer. The grower washer must always be put on top of the flat washer;
- connect the second bypass neutral cable to the hole at the top of the accessory for double cable using a hex M10x35 screw along with M10 flat washer and M10 grower washer. Through this screw, fix the accessory to the terminal of the neutral busbar. The grower washer must always be put on top of the flat washer.

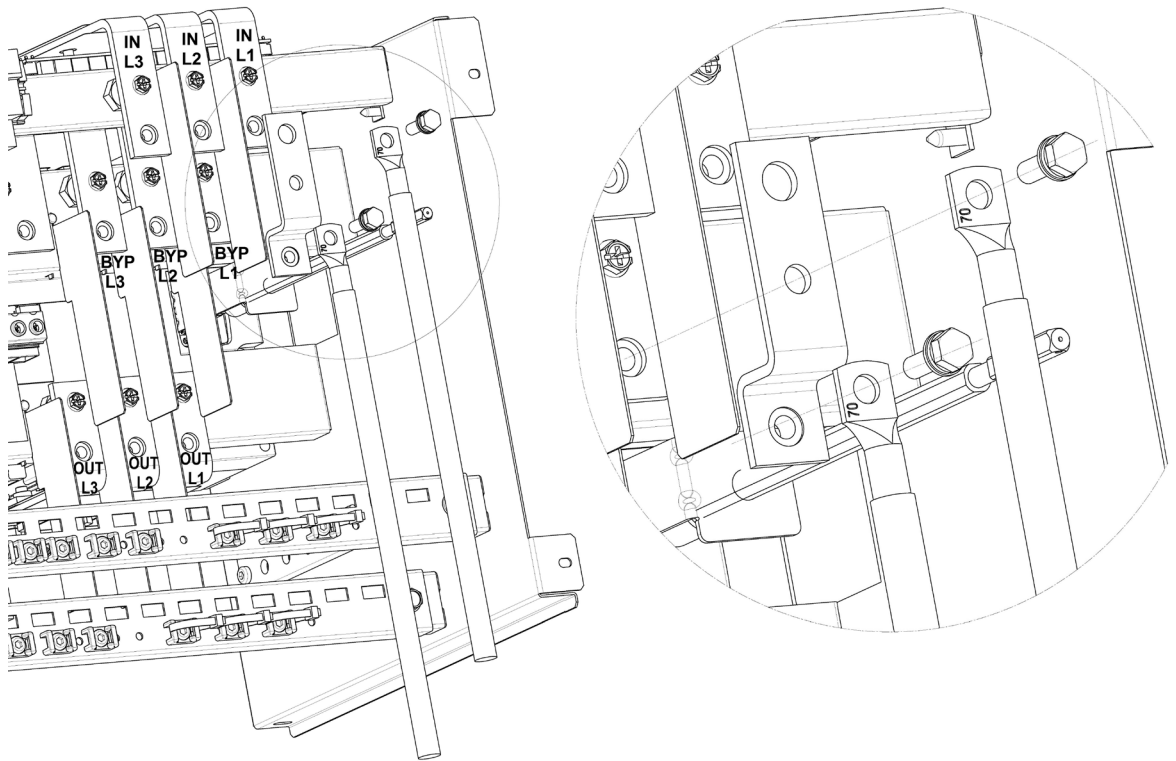

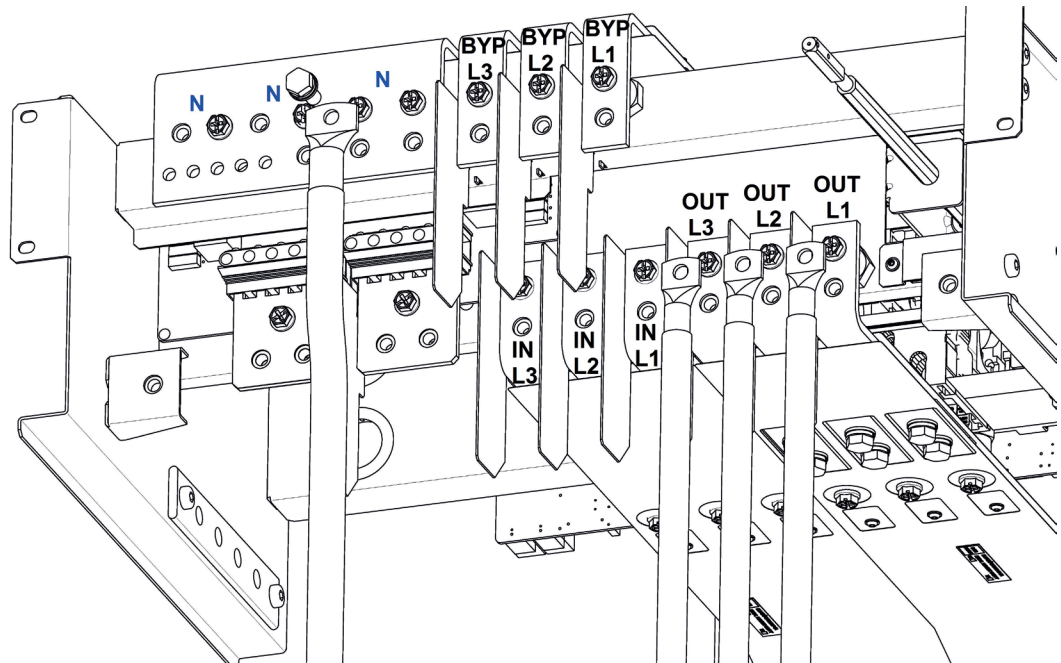

KEOR MOD 125 – output cables installation

It is also possible to install an accessory for double cable. In this way it is possible for each terminal to use two cables with a smaller cross section than the one of a single cable.

For this installation, follow these steps:

- crimp the output and neutral cables with M8 eyelets;
- connect the first three output cables L1, L2, L3 to the hole at the bottom of the accessory for double cable using three hex M8x20 screws along with M8 flat washers and M8 grower washers. The grower washer must always be put on top of the flat washer;
- connect the other three output cables L1, L2, L3 to the hole at the top of the accessory for double cable using three hex M8x25 screws along with M8 flat washers and M8 grower washers. Through these screws, fix the accessories to the terminals OUT L1, OUT L2, OUT L3 of the input busbar. The grower washer must always be put on top of the flat washer;
- do not change the phase sequence (L1, L2, L3);
- connect the first output neutral cable to the hole at the bottom of the accessory for double cable using a hex M8x20 screw along with a M8 flat washer and a M8 grower washer. The grower washer must always be put on top of the flat washer;
- connect the second output neutral cable to the hole at the top of the accessory for double cable using a hex M8x25 screw along with M8 flat washer and M8 grower washer. Through this screw, fix the accessory to the terminal of the neutral busbar. The grower washer must always be put on top of the flat washer.

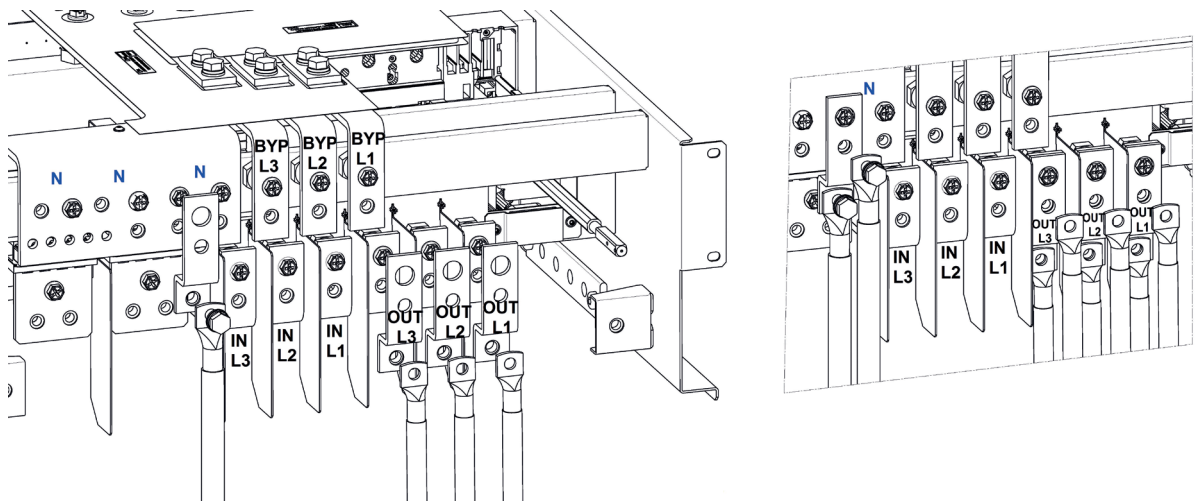

KEOR MOD 125 – output cables installation with accessories for double cable

4. Installation

KEOR MOD 250

Follow these steps:

- crimp the output and neutral cables with M10 eyelets;
- connect the output cables L1, L2, L3 to the terminals OUT L1, OUT L2, OUT L3 of the output busbar using three hex M10x30 screws along with M10 flat washers and M10 grower washers. The grower washer must always be put on top of the flat washer;
- do not change the phase sequence (L1, L2, L3);
- connect the output neutral cable to the neutral busbar with a hex M10x30 screw along with a M10 flat washer and a M10 grower washer. The grower washer must always be put on top of the flat washer.

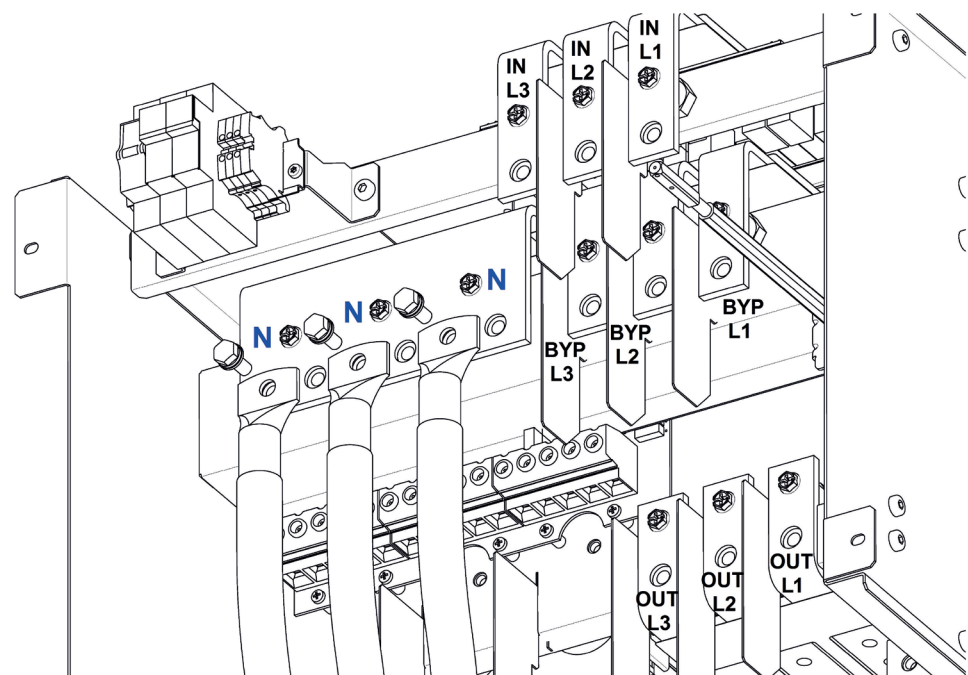
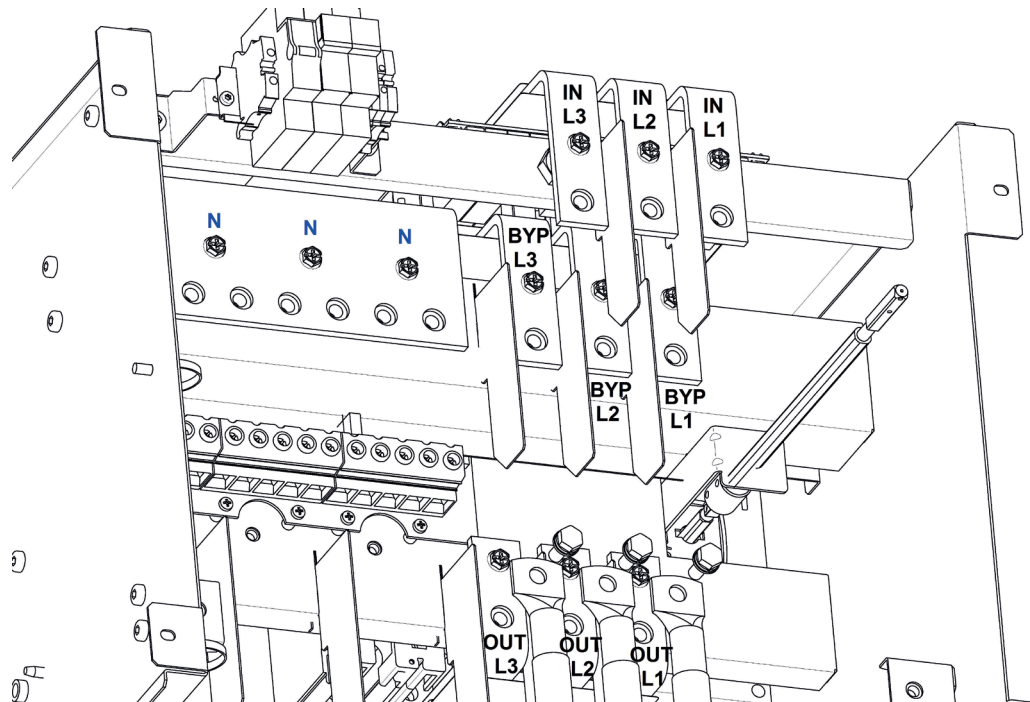

KEOR MOD 250 – output cables installation

It is also possible to install an accessory for double cable. In this way it is possible for each terminal to use two cables with a smaller cross section than the one of a single cable.

For this installation, follow these steps:

- crimp the output and neutral cables with M10 eyelets;
- connect the first three output cables L1, L2, L3 to the hole at the bottom of the accessory for double cable using three hex M10x30 screws along with M10 flat washers and M10 grower washers. The grower washer must always be put on top of the flat washer;
- connect the other three output cables L1, L2, L3 to the hole at the top of the accessory for double cable using three hex M10x35 screws along with M10 flat washers and M10 grower washers. Through these screws, fix the accessories to the terminals OUT L1, OUT L2, OUT L3 of the output busbar. The grower washer must always be put on top of the flat washer;
- do not change the phase sequence (L1, L2, L3);
- connect the first output neutral cable to the hole at the bottom of the accessory for double cable using a hex M10x30 screw along with a M10 flat washer and a M10 grower washer. The grower washer must always be put on top of the flat washer;
- connect the second output neutral cable to the hole at the top of the accessory for double cable using a hex M10x35 screw along with M10 flat washer and M10 grower washer. Through this screw, fix the accessory to the terminal of the neutral busbar. The grower washer must always be put on top of the flat washer.

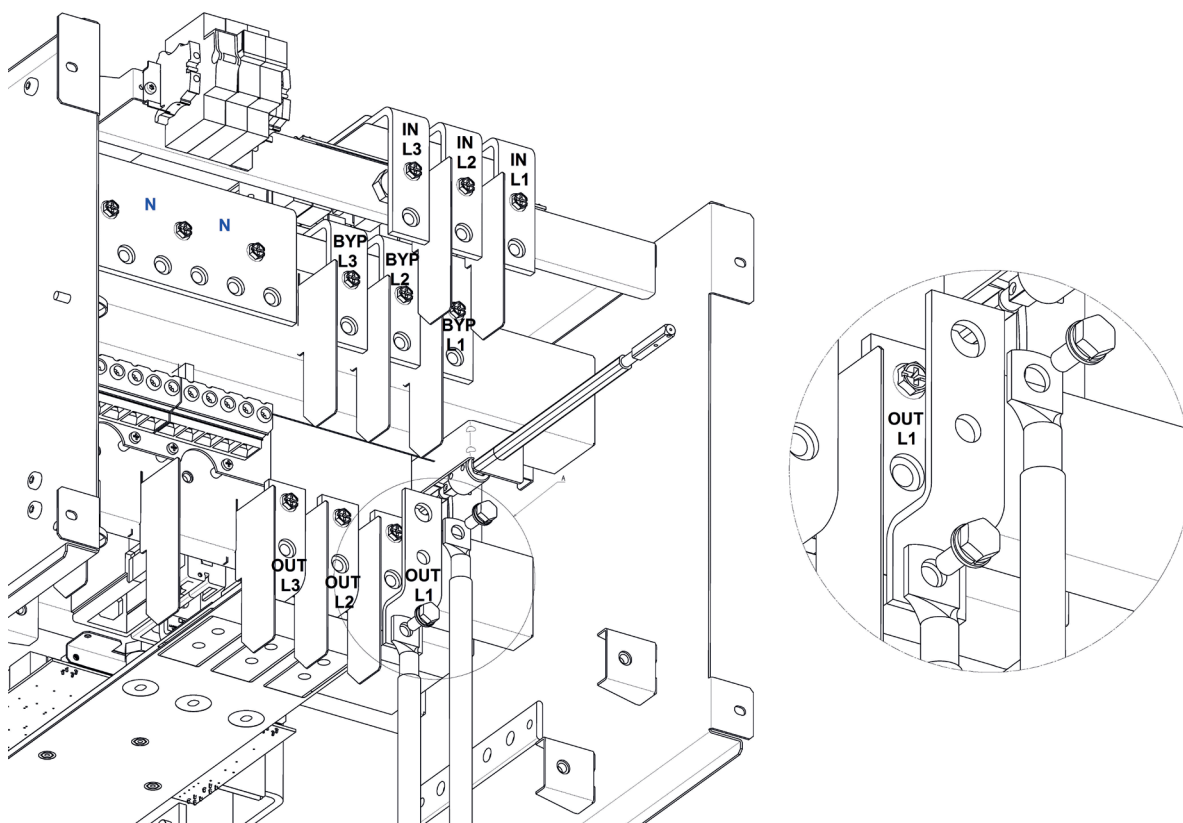

KEOR MOD 125

The default configuration has the strings of batteries in common.

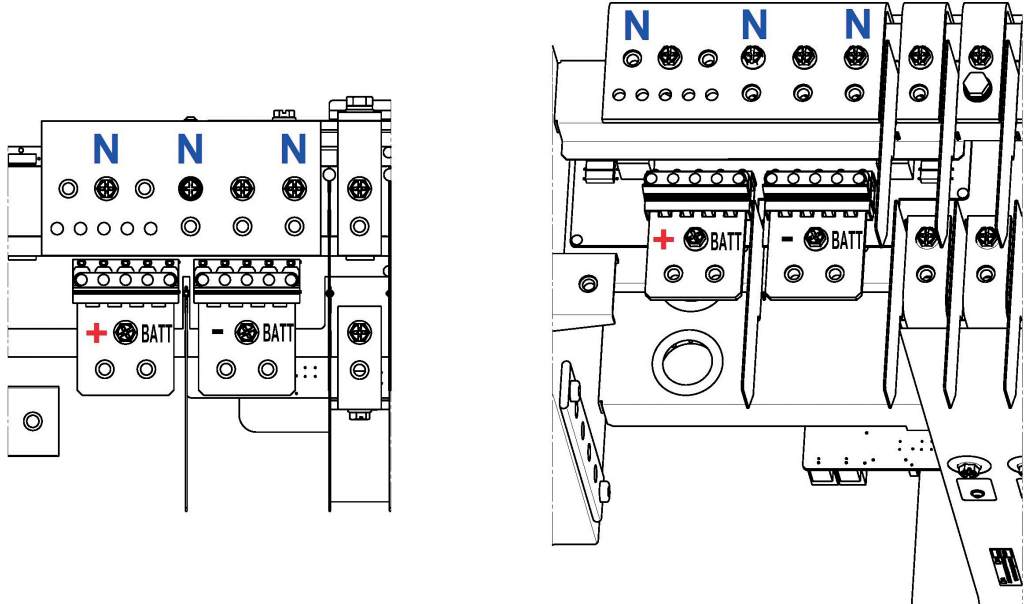

KEOR MOD 125 – battery terminals

If no change is required, follow these steps:

- crimp the positive, negative and neutral battery cables with M8 eyelets;
- connect the positive cable of the battery cabinet to the + BATT terminal using a hex M8x20 screw along with M8 flat washer and M8 grower washer. The grower washer must always be put on top of the flat washer;
- connect the negative cable of the battery cabinet to the - BATT terminal using a hex M8x20 screw along with M8 flat washer and M8 grower washer. The grower washer must always be put on top of the flat washer;
- connect the neutral cable of the battery cabinet to the neutral busbar using a hex M8x20 screw along with M8 flat washer and M8 grower washer. The grower washer must always be put on top of the flat washer.

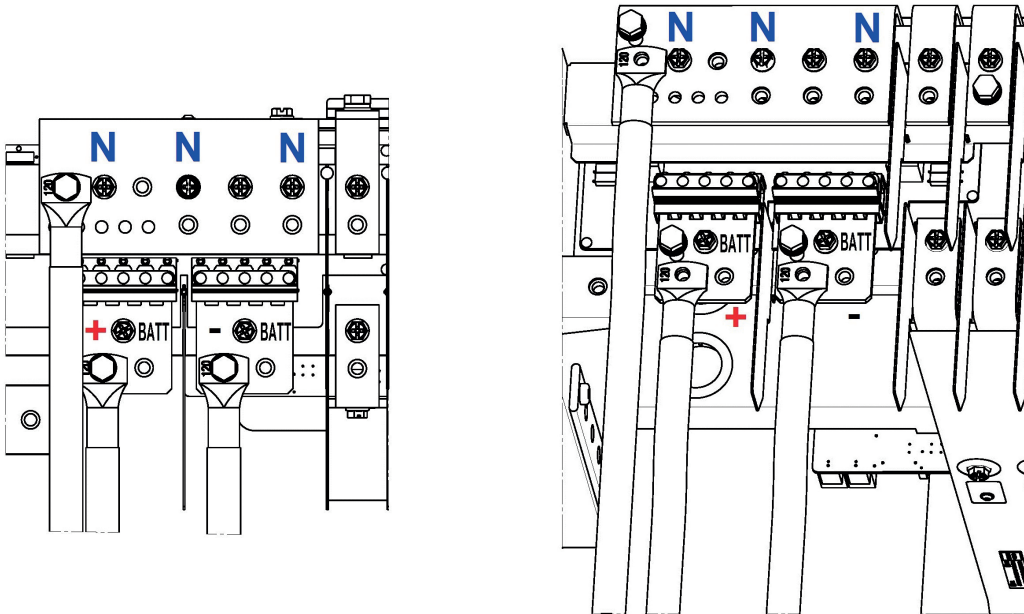

KEOR MOD 125 – battery cables installation with strings of batteries in common

4. Installation

In case there is the need to use a double cable for each terminal in order to use a smaller cross section for each cable, follow the previous procedure but install two cables for each terminal.

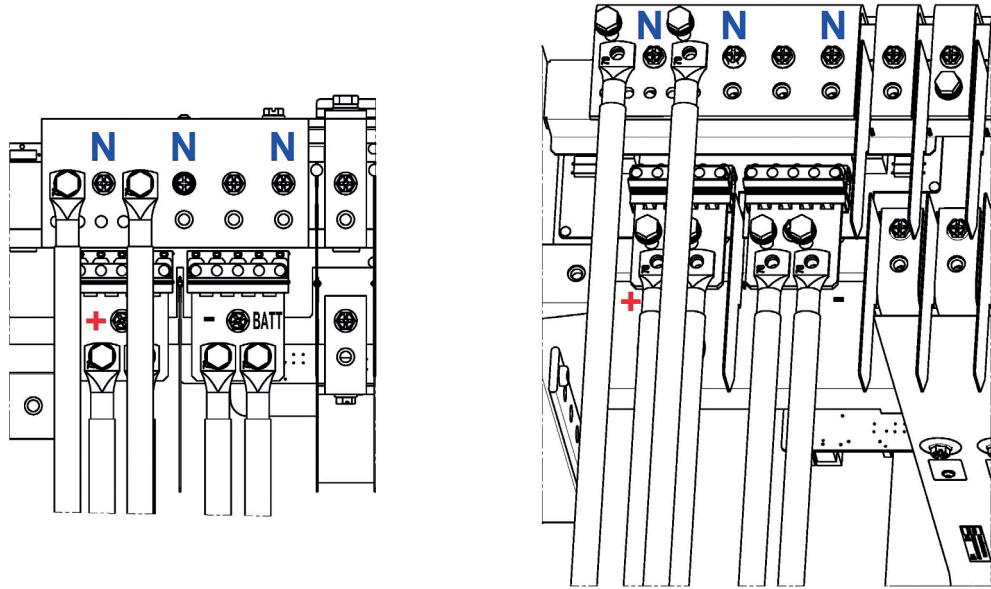

KEOR MOD 125 – battery cables installation with strings of batteries in common (double cable)

It is also possible to install independent string of batteries. In this case, each power module is associated to a unique string. The following picture shows the association between the power modules and the relative battery strings:

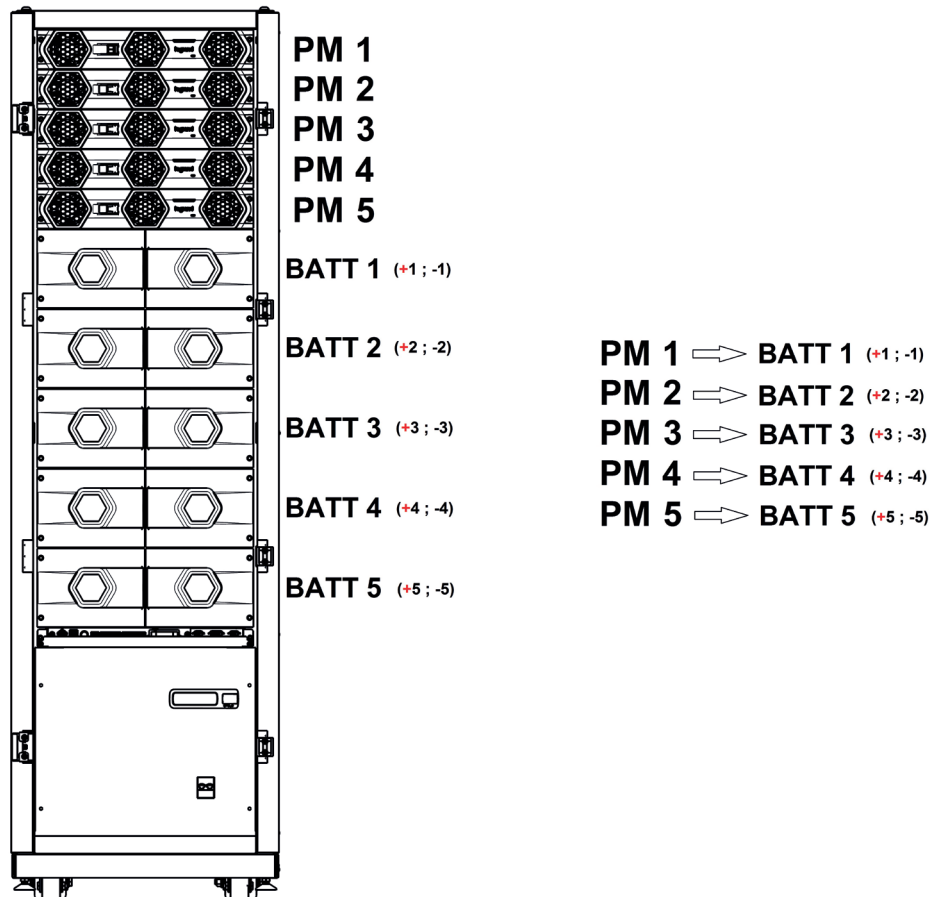

In case of installation of independent strings of batteries, follow these steps:

- remove the metal jumpers inserted in the positive and negative battery terminals.

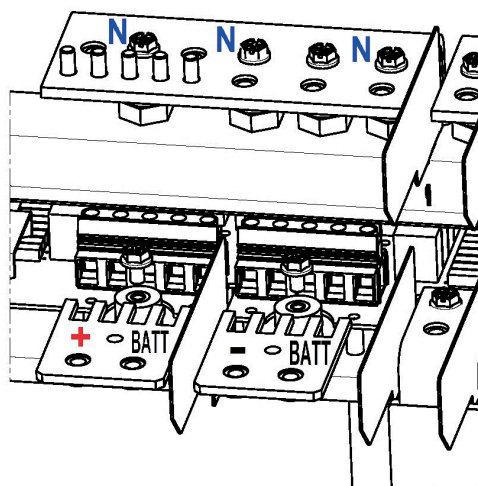

- remove the supports for the metal jumpers.

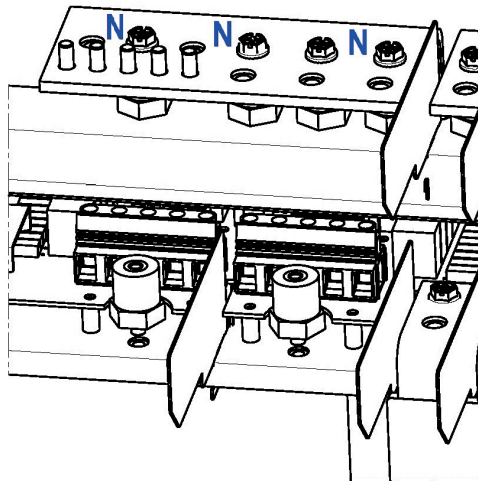

- insert the positive battery cables of the battery cabinets in the positive battery terminal and the negative battery cables of the battery cabinets in the negative battery terminal.

The maximum cross section accepted by the terminals is 16 mm².

Connect the battery cables on the terminals according to the string:

BATT1: +1 ; -1

BATT2: +2 ; -2

BATT3: +3 ; -3

BATT4: +4 ; -4

BATT5: +5 ; -5

4. Installation

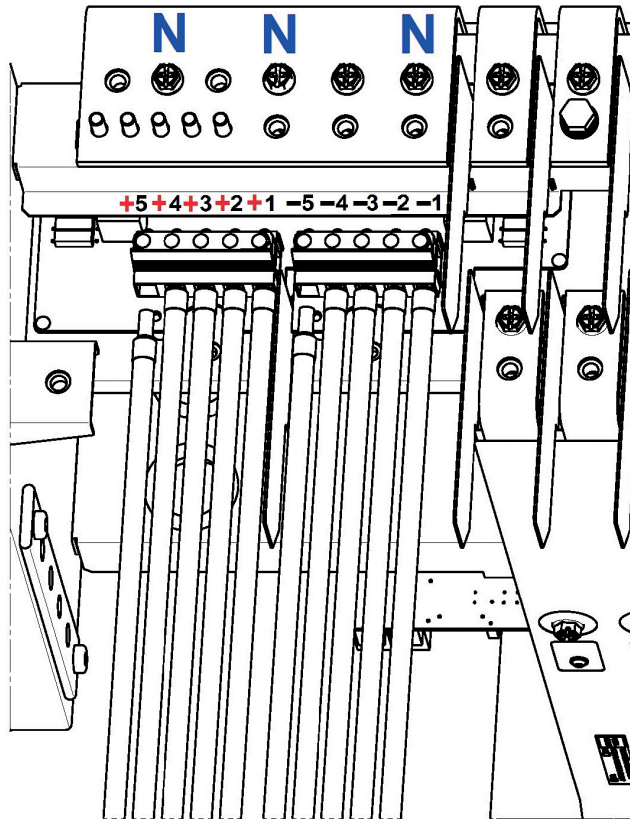

- take from the accessory box the metal support for the neutral battery cables and install it in the relative position on the neutral busbar.

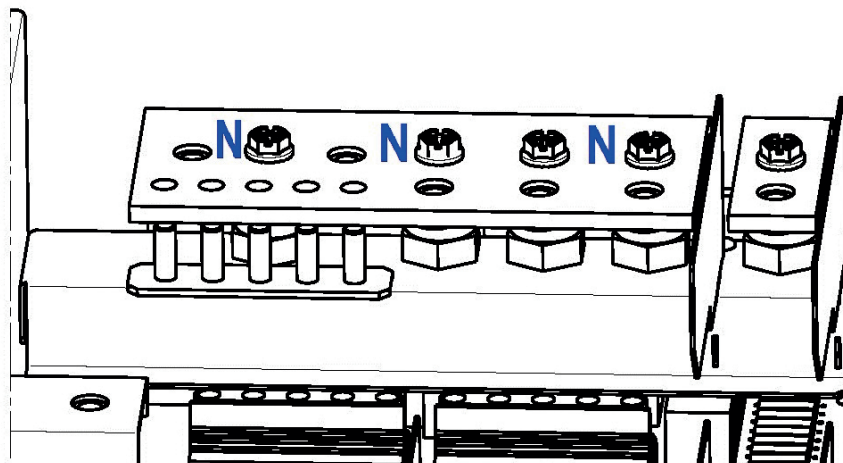

- crimp the neutral battery cables with M5 eyelets;
- connect the neutral cables of the battery cabinets to the metal support of the neutral busbar using hex M5 nuts along with M5 flat washer and M5 grower washers present in the accessory box. The grower washer must always be put on top of the flat washer.

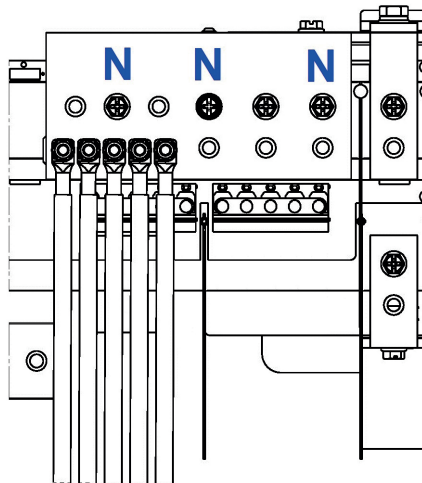
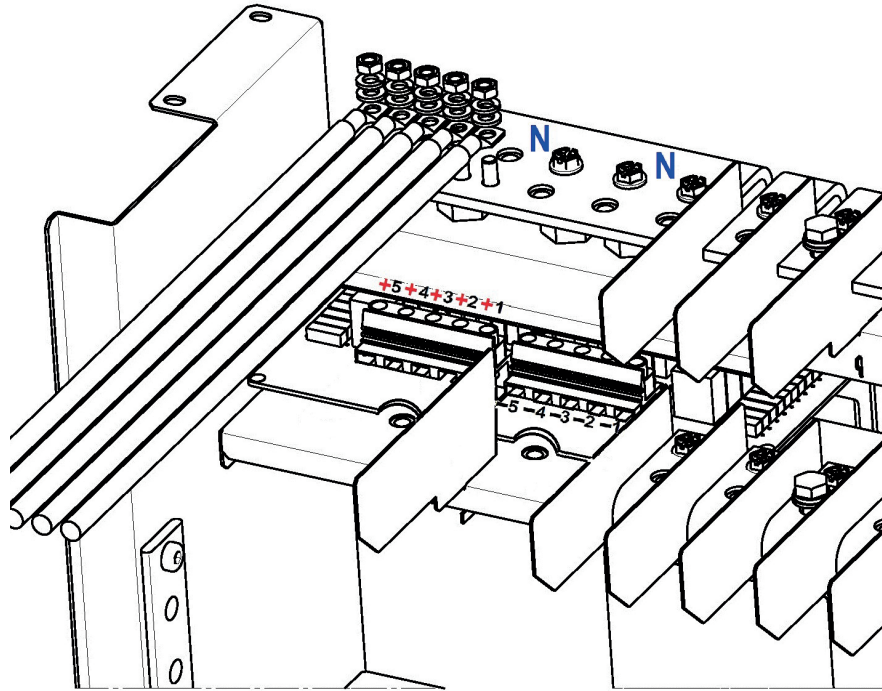

4. Installation

KEOR MOD 250

The default configuration has the strings of batteries in common.

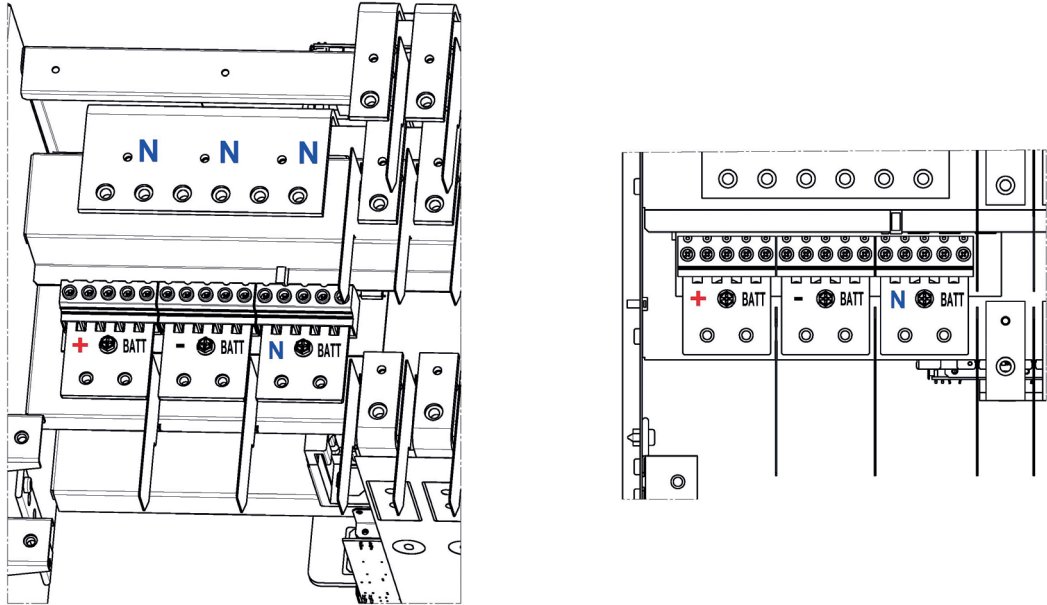

KEOR MOD 250 – battery terminals

If no change is required, follow these steps:

- crimp the positive, negative and neutral battery cables with M8 eyelets;
- connect the positive cable of the battery cabinet to the + BATT terminal using a hex M8x20 screw along with M8 flat washer and M8 grower washer. The grower washer must always be put on top of the flat washer;
- connect the negative cable of the battery cabinet to the - BATT terminal using a hex M8x20 screw along with M8 flat washer and M8 grower washer. The grower washer must always be put on top of the flat washer;
- connect the neutral cable of the battery cabinet to the N BATT terminal using a hex M8x20 screw along with M8 flat washer and M8 grower washer. The grower washer must always be put on top of the flat washer.

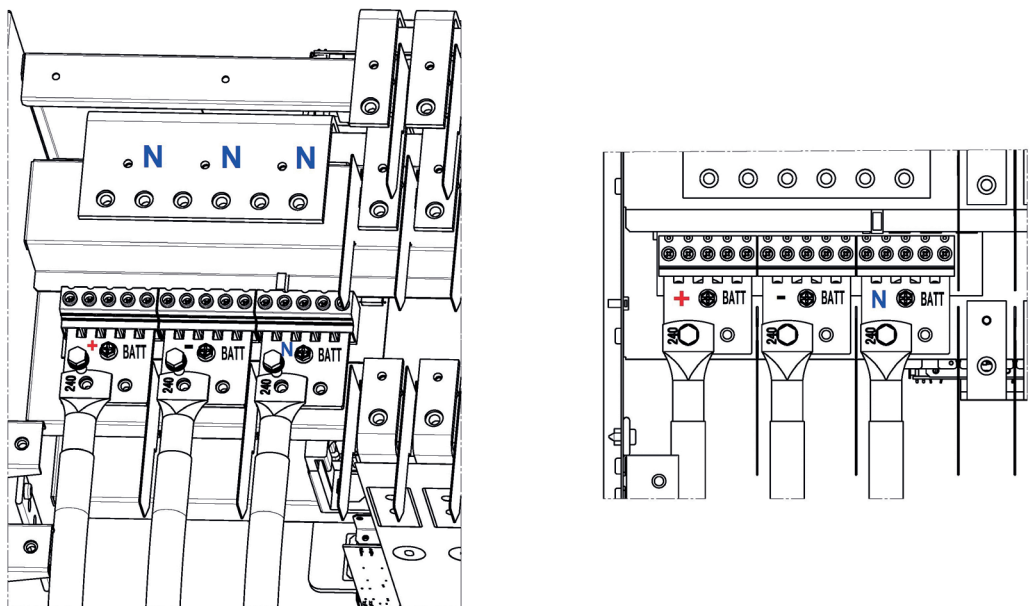

KEOR MOD 250 – battery cables installation with strings of batteries in common

In case there is the need to use a double cable for each terminal in order to use a smaller cross section for each cable, follow the previous procedure but install two cables for each terminal.

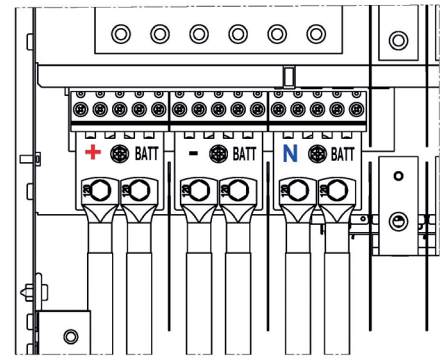
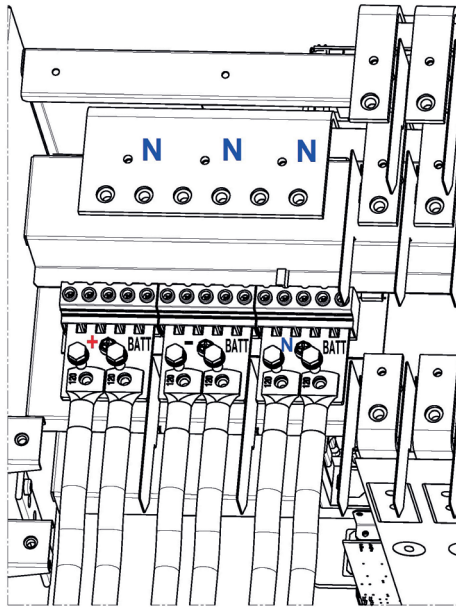

KEOR MOD 250 – battery cables installation with strings of batteries in common (double cable)

It is also possible to install independent string of batteries. In this case, each power module is associated to a unique string. The following picture shows the association between the power modules and the relative battery strings:

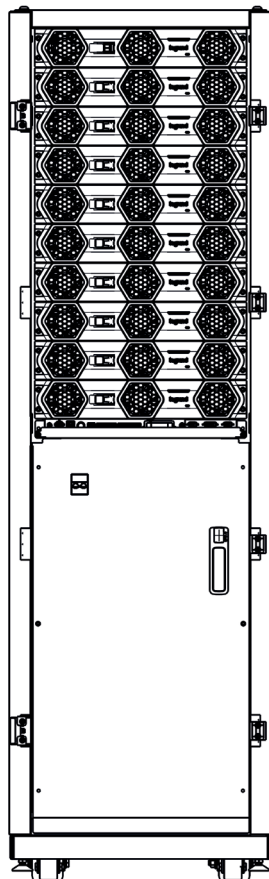

- PM 1
- PM 2
- PM 3
- PM 4
- PM 5
- PM 6
- PM 7
- PM 8
- PM 9
- PM 10

- PM 1 → BATT 1 (+1 ; -1)
- PM 2 → BATT 1 (+1 ; -1)
- PM 3 → BATT 2 (+2 ; -2)
- PM 4 → BATT 2 (+2 ; -2)
- PM 5 → BATT 3 (+3 ; -3)
- PM 6 → BATT 3 (+3 ; -3)
- PM 7 → BATT 4 (+4 ; -4)
- PM 8 → BATT 4 (+4 ; -4)
- PM 9 → BATT 5 (+5 ; -5)
- PM 10 → BATT 5 (+5 ; -5)

4. Installation

In case of installation of independent strings of batterie, follow these steps:

- remove the metal jumpers inserted in the battery terminals.

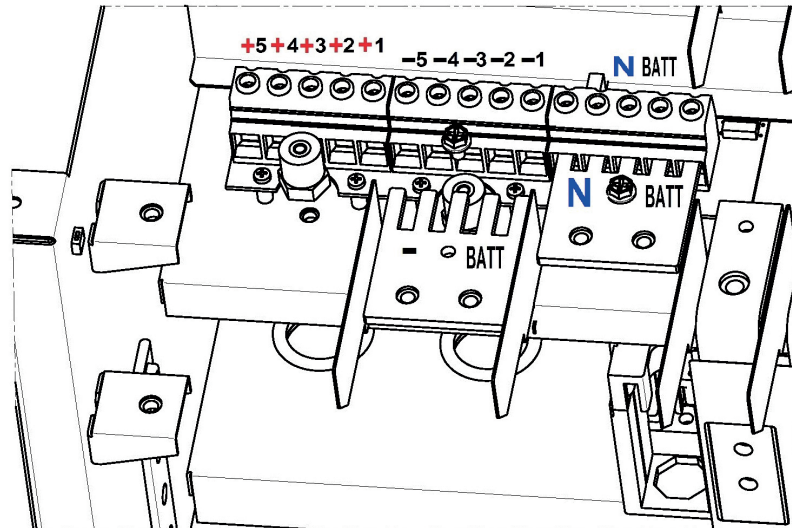

- insert the positive battery cables of the battery cabinets in the positive battery terminal, the negative battery cables of the battery cabinets in the negative battery terminal and the neutral battery cables of the battery cabinets in the neutral battery terminal.

The maximum cross section accepted by the terminals is 35 mm².

Connect the battery cables on the terminals according to the string:

BATT1: +1 ; -1

BATT2: +2 ; -2

BATT3: +3 ; -3

BATT4: +4 ; -4

BATT5: +5 ; -5

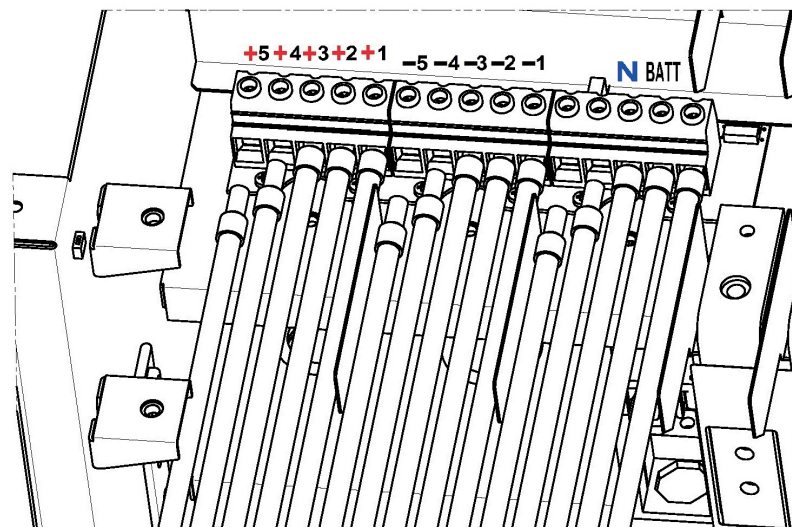

4.2.11 Parallel system

It is possible to connect up to three UPS in parallel to support redundancy. The UPS connected to the parallel system must be of the same type (i.e., Keor MOD 125 can be installed in a parallel system only with others Keor MOD 125) and the maximum difference in the number of PM of the cabinets is two.

The maximum load rate that can be supported by a parallel configuration is the same as for a single configuration. However, if one UPS becomes inoperable, the other units supplies the load without any load drop.

For the configuration of the parallel system, the first thing to do is to set the ID address of each UPS in the parallel system by means of the rotary switch of the SSS interface:

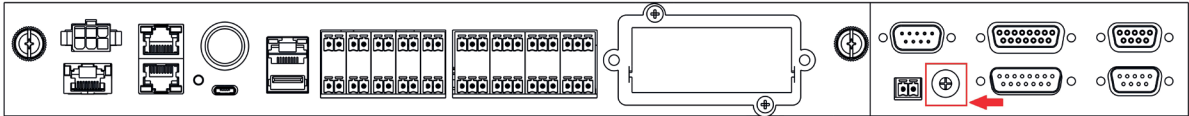

For Keor MOD 125, the ID address must be from 0 to 2. For Keor MOD 250, the ID address must be from 4 to 6.

If there is a parallel of two to three Keor MOD 125, this is the ID to set on each UPS:

- UPS 1 : ID=0
- UPS 2 : ID=1
- UPS 3 : ID=2

The limit for the parallel for Keor MOD 250 is a total of 24 PM. It is possible to have a parallel of two full UPS units or of three UPS units having eight PM each. If there is a parallel of two to three Keor MOD 250 cabinets, this is the ID to set on each UPS:

- UPS 1 : ID=4
- UPS 2 : ID=5
- UPS 3 : ID=6

The BYPASS-SYNC and CAN-BUS ports of the SSS interfaces of the UPS must be connected among themselves as indicated in the following pictures:

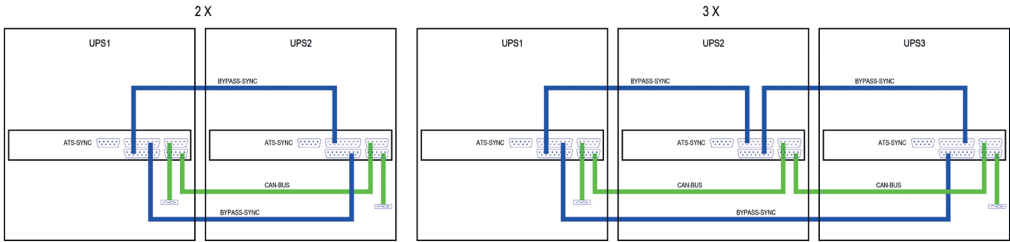
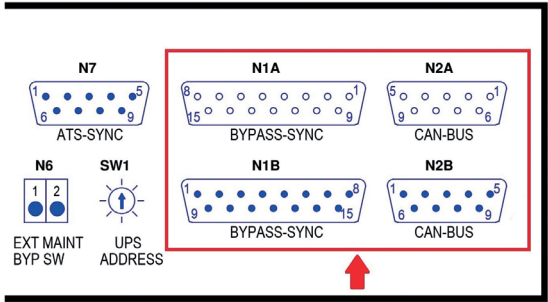

4. Installation

The cables for the connections of the ports of the SSS interfaces must have the following characteristics:

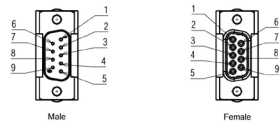
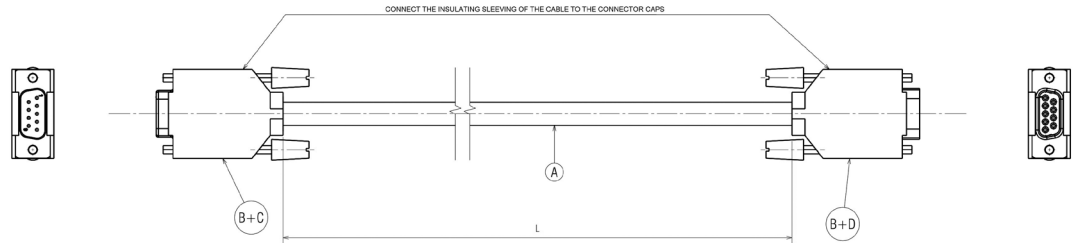

A: Belden 4 Pair Screened Multipair Industrial Cable, 28 AWG, 300V, twisted pair, Mfr. Part No.: 8134 060100
 B: Amphenol FCI 8655MH Series Die Cast Zinc D-sub Connector Hood, 9 Way, Strain Relief, Mfr. Part No.: 8655MH0901BLF
 C: Amphenol FCI Panel Mount, 9 Pin D-sub Connector Socket, Shell Size E, Mfr. Part No.: DE09S064TLF
 D: Amphenol FCI Panel Mount, 9 Pin D-sub Connector Plug, Shell Size E, Mfr. Part No.: DE09P064TXLF

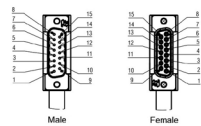
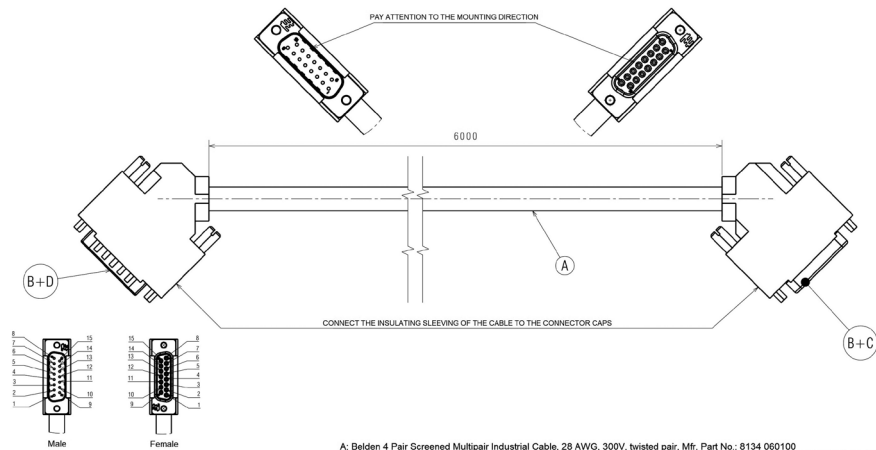
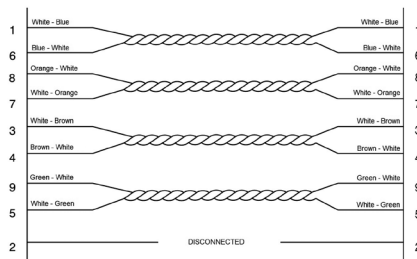

A: Belden 4 Pair Screened Multipair Industrial Cable, 28 AWG, 300V, twisted pair, Mfr. Part No.: 8134 060100
 B: Amphenol FCI Economical Series Die Cast Zinc Right Angle Backshell, 15 Way, Strain Relief, Mfr. Part No.: 8655MHRA1501LF
 C: Amphenol FCI Panel Mount, 15 Pin D-sub Connector Socket, Shell Size A, Mfr. Part No.: DA15S064TLF
 D: Amphenol FCI Panel Mount, 15 Pin D-sub Connector Plug, Shell Size A, Mfr. Part No.: DA15P064TXLF

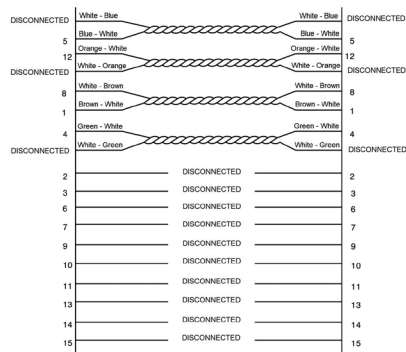

The cables can pass on the cabinet as indicated in the following pictures:

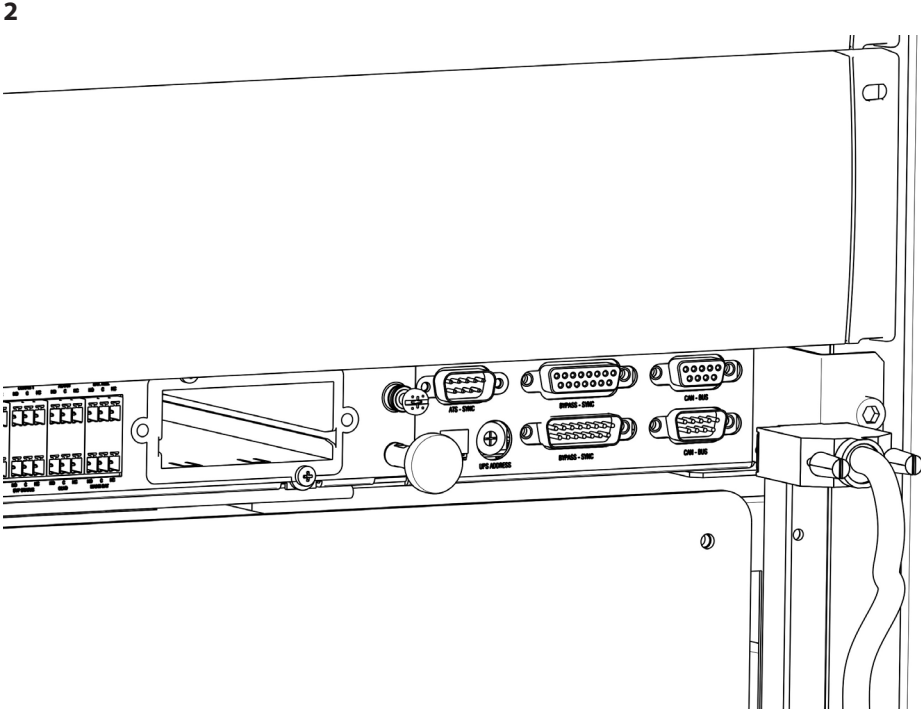
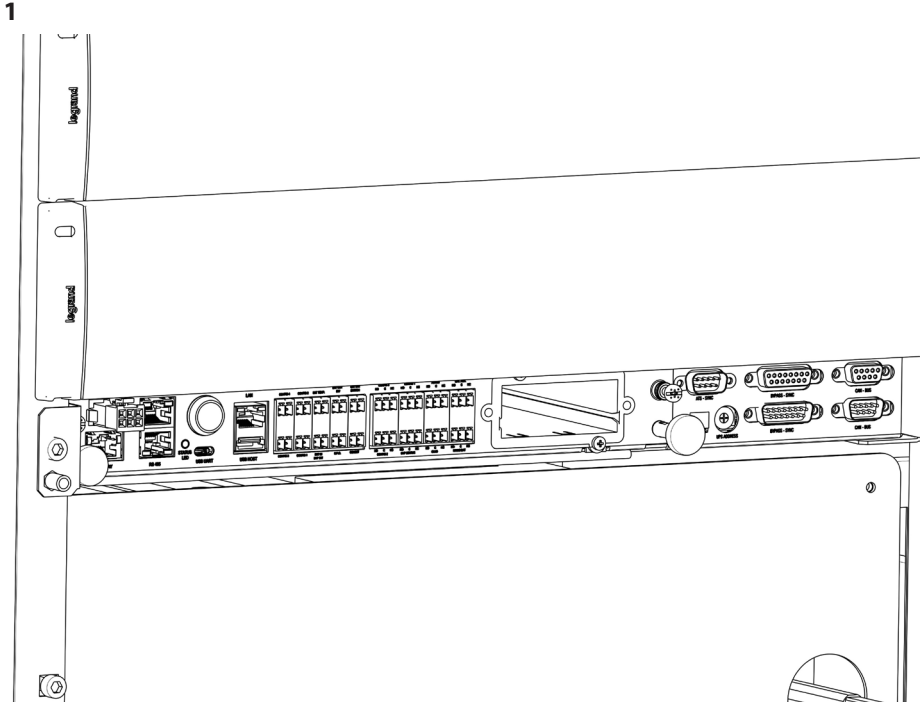

4. Installation

3

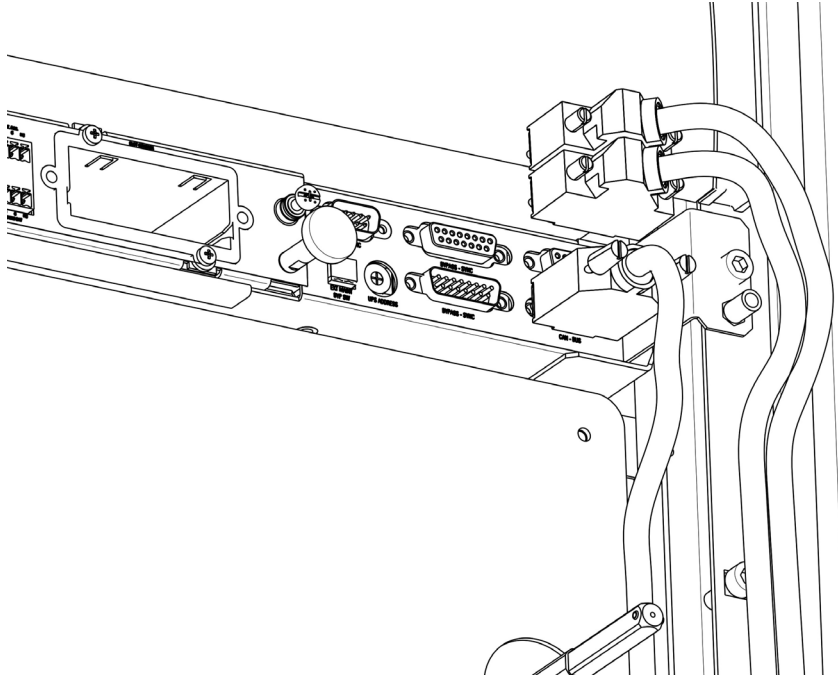

4

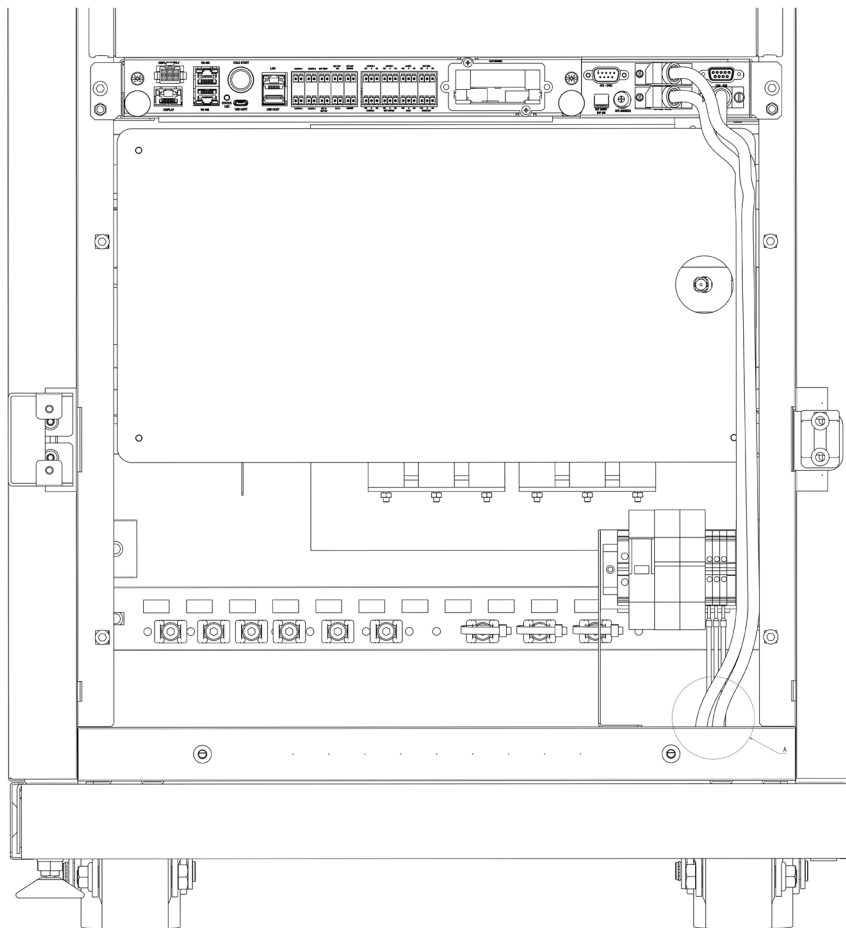

The first and the last UPS of the parallel system must be terminated. To do this, remove the fixed part of the SSS interface from the cabinet following the steps indicated on paragraph 6.3.3.

The fixed part of the SSS interface has two dip switches. SW2 is linked to N2B (the male connector of the CAN-BUS port of the SSS interface). SW3 is linked to N2A (the female connector of the CAN-BUS port of the SSS interface).

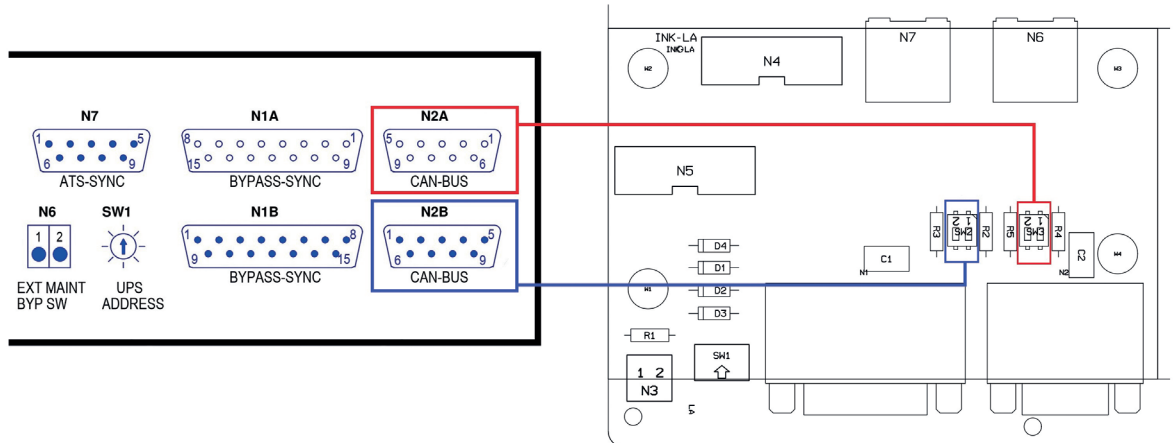

According to which CAN-BUS port is used on the first and on the last UPS of the parallel system, the relative dip switch must be set to ON if the port is free or to OFF if the cable is connected.

For example, for the configuration shown before, set the dip switch as indicated in the following picture:

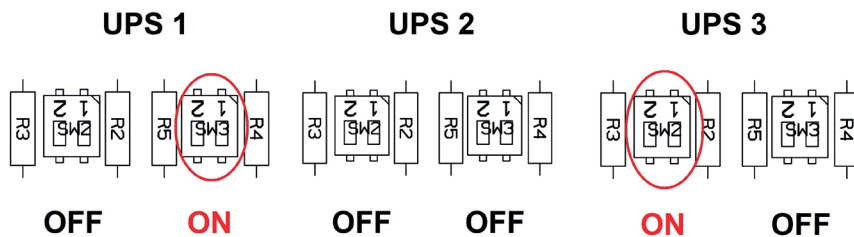
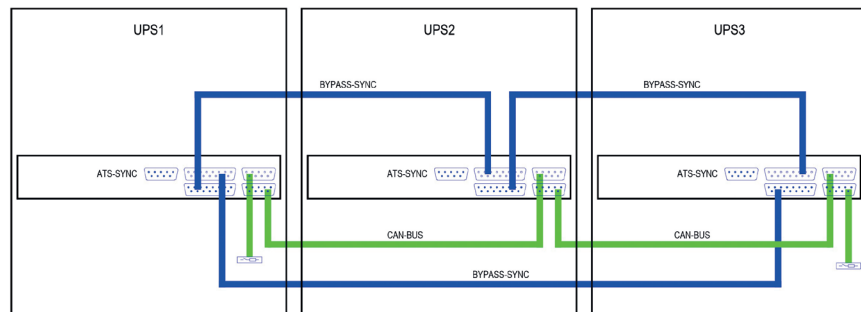

4. Installation

For the installation of the cables for the parallel system, it is recommended to provide an external system bypass as indicated in the following connection diagram:

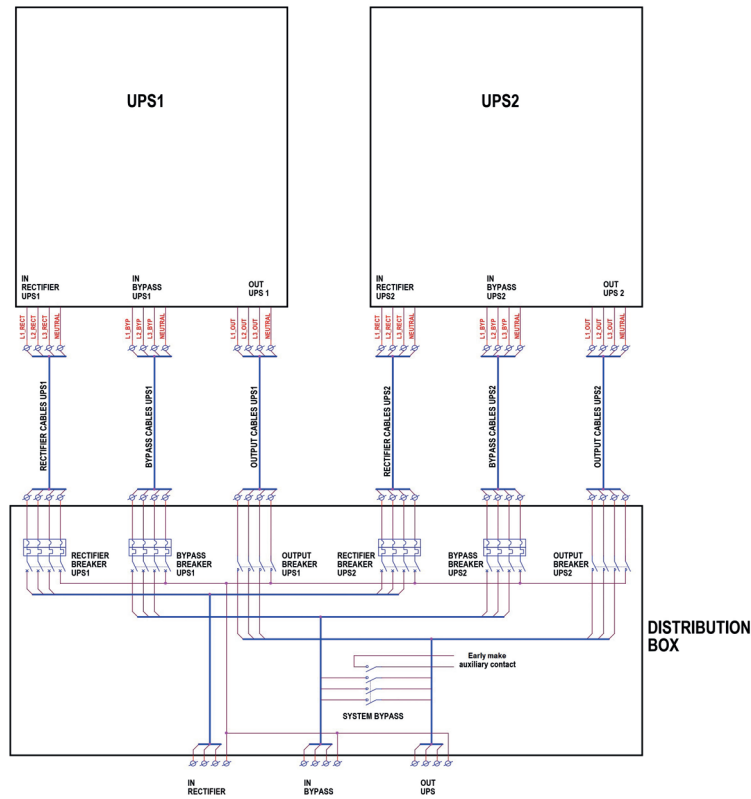

Follow these steps:

- connect the PE (Protective Earth) between the UPS units to ensure an equipotential bonding;
- connect the input line and the bypass line (including the earthing cable) of the mains to the distribution box where it also present the external system bypass;
- connect the load to the output line of the distribution box;
- connect the input cables for each UPS (see paragraph 4.2.7) to the input line of the distribution box;
- connect the bypass cables for each UPS (see paragraph 4.2.8) to the bypass line of the distribution box. These cables must have the same length and the same cross section;
- connect the output cables for each UPS (see paragraph 4.2.9) to the output line of the distribution box. These cables must have the same length and the same cross section.

Use only the external system bypass for maintenance and block the maintenance bypass of each single UPS unit to 0 (open) with a lock.

An early make contact of the external maintenance bypass must be connected to the N6 terminal of the SSS interface (EXT MAINT BYP SW) of one UPS unit of the parallel system (see paragraph 4.5).

If redundancy is required, add an early make contact from the external maintenance bypass for each N6 terminal of the SSS interfaces of the UPS units.

The following diagram indicates how to connect battery cabinets to a parallel system:

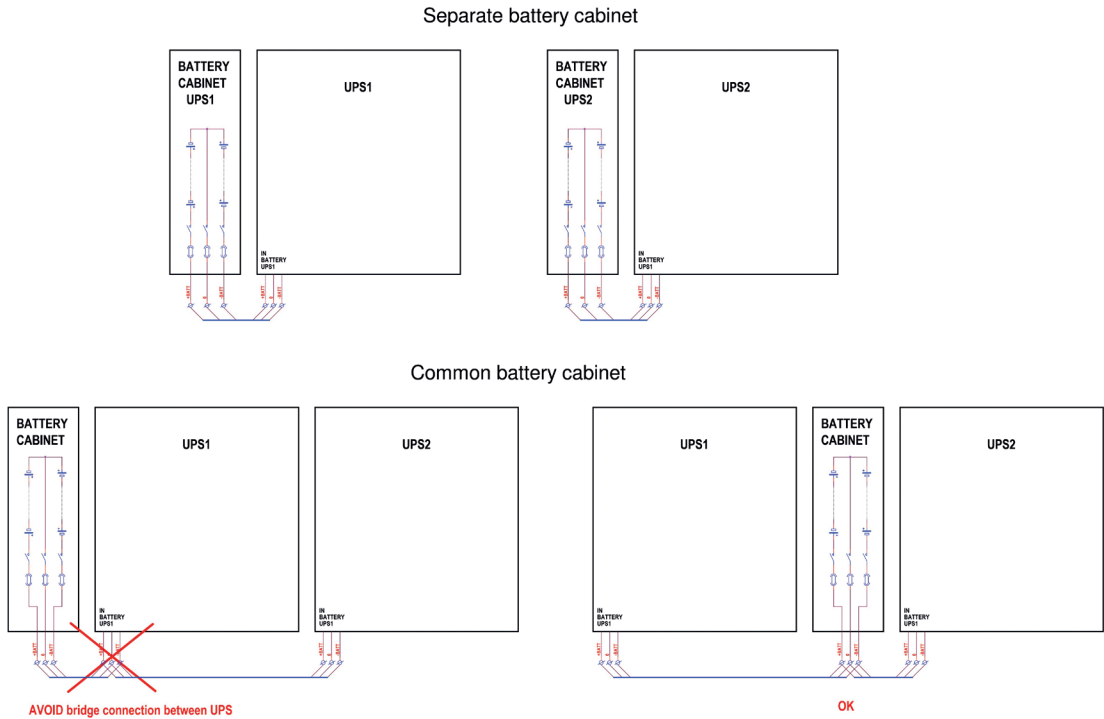

4.2.12 Installation with STS (Static Transfer System)

Static Transfer Systems (STS) are intelligent units that transfer the load to an alternative source when the primary source is out of tolerance. This ensures “high availability” of the power supply for sensitive or critical installations. Normally, STS provide redundancy between 2 independent UPS systems and each STS is sized according to the load it protects.

Follow the installation manual of the STS for the electrical installation of the Keor MOD UPS systems to the STS.

The ATS-SYNC ports of the SSS interfaces of the first UPS of each system (the one having lower ID number) must be connected to each other using the Keor Mod cross sync cable Cat. Nos. 3 102 59

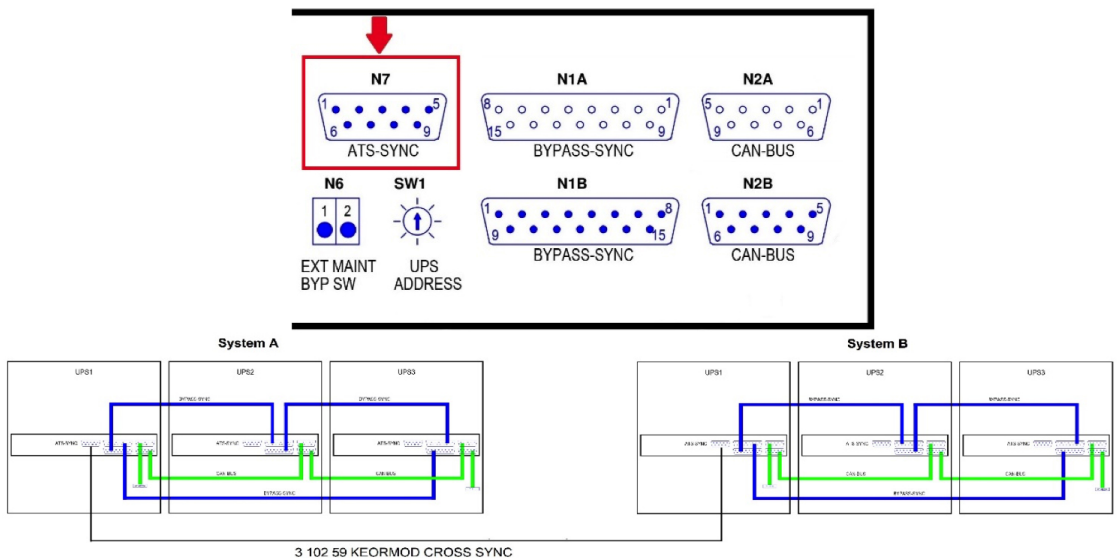

For the configuration of this function, check paragraph 5.2 about the start-up procedure.

4. Installation

4.3 Power modules installation

Once all the electrical connections have been made, close the distribution panels and fix them by screwing all the hex socket M6x16 screws along with M6 toothed washers.

It is then possible to move onto the insertion of the power modules into the UPS.

During the installation it is necessary to use the appropriate Personal Protective Equipment like protective gloves and anti-accident shoes (see paragraph 2.3).

INDICATION

To guarantee the stability of the Keor MOD 125 cabinet, first install the power modules and only later the battery drawers.

Insert the power modules one at a time starting from the top of the cabinet.

Insert two screwdrivers in the upper parts of the plastic slot cover where the power module must be installed. Slightly turn the screwdrivers down to unhook the cover.

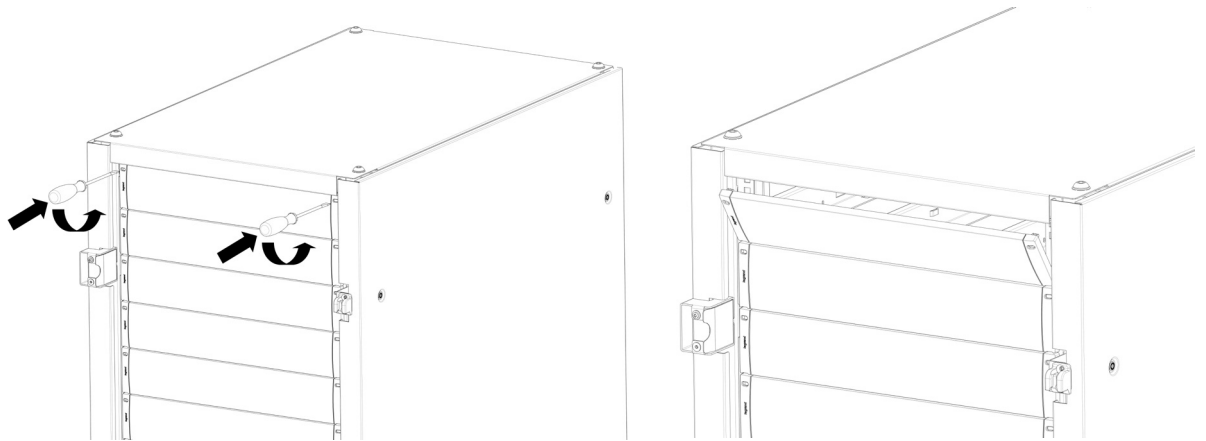

Handle the power module from his sides and never from the front.

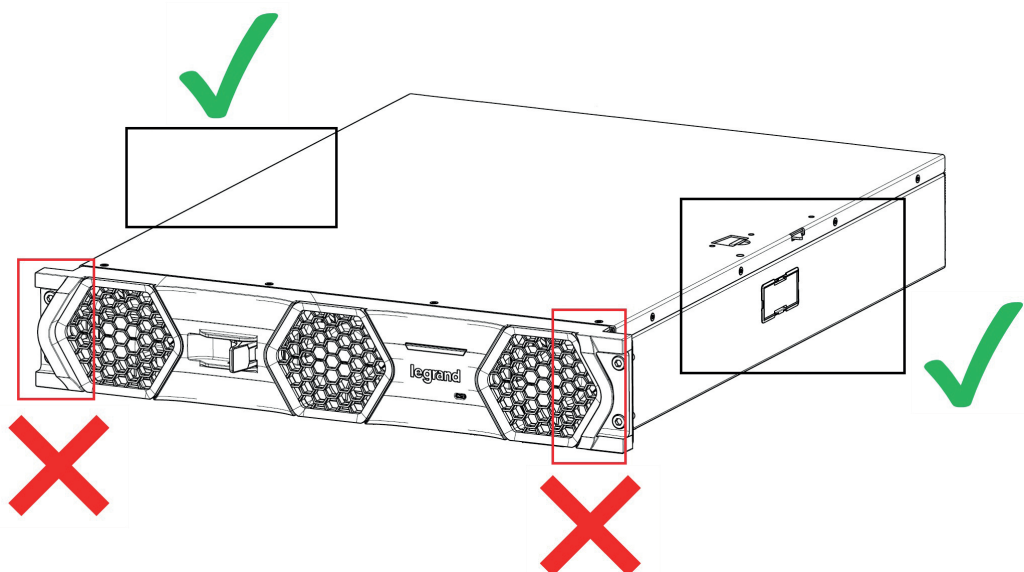

Remove the film protector from the front of the power module. Insert the power module in the free slot, making sure that its switch in the front is open.

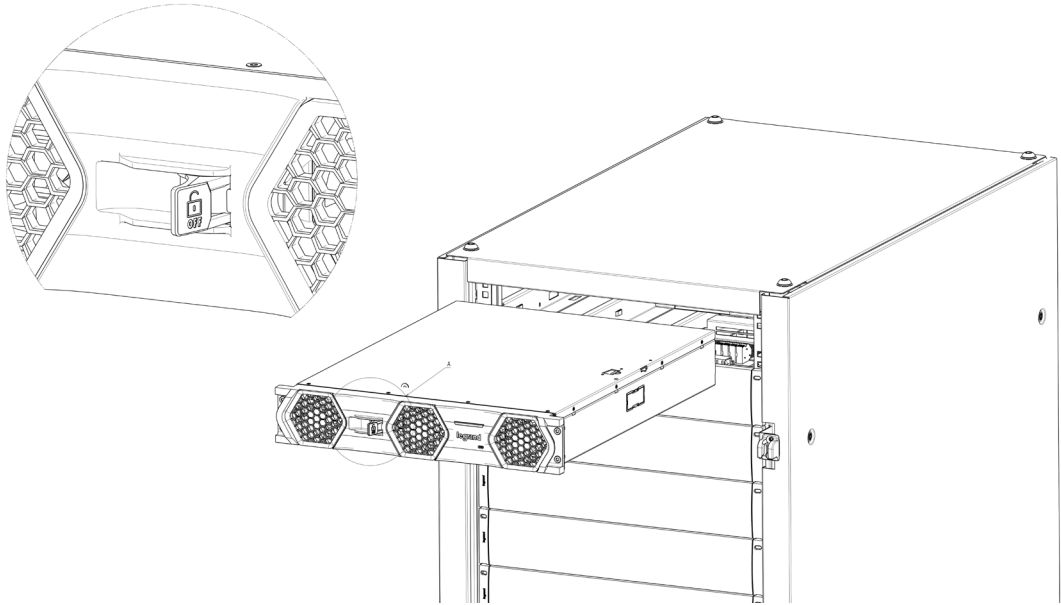

Make sure that the power module is abut and then close its front switch. Fix the module to the cabinet with four screws included in the accessory kit.

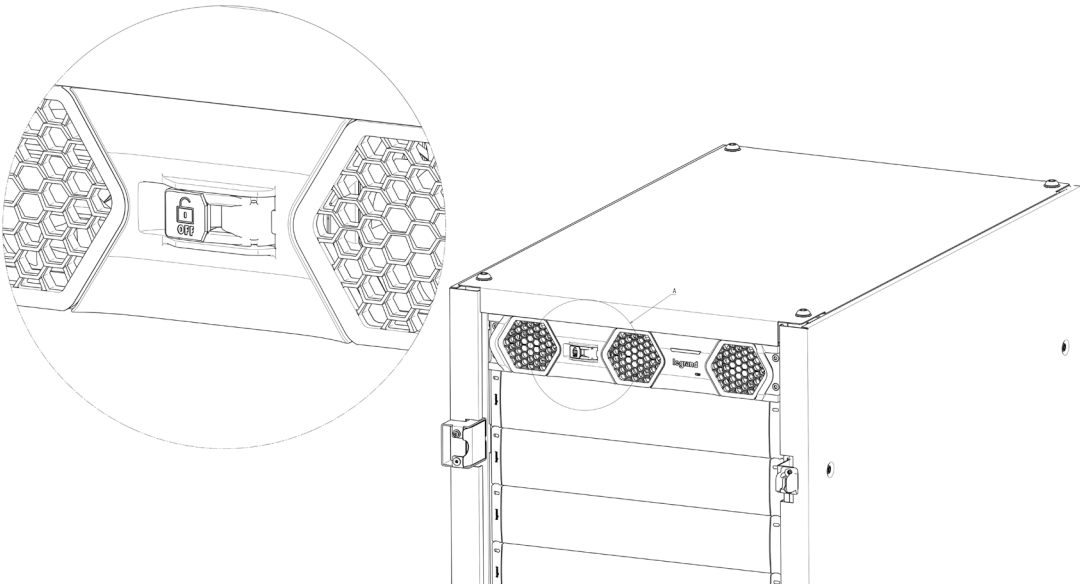

4. Installation

4.4 Battery drawers installation

The cabinet for Keor MOD 125 may include two to ten internal battery drawers. Each battery string is made up of two drawers, therefore it is necessary to install them two by two.

The battery drawers have a specific order in the cabinet that must be kept, especially if the UPS has to work in a configuration with independent strings of batteries.

During the installation it is necessary to use the appropriate Personal Protective Equipment (see paragraph 2.3).

There must be at least 1 KB (Battery Kit) every 25 kVA of nominal UPS power. For internal battery drawers and for external modular battery units, 1 KB is made up of 2 battery drawers.

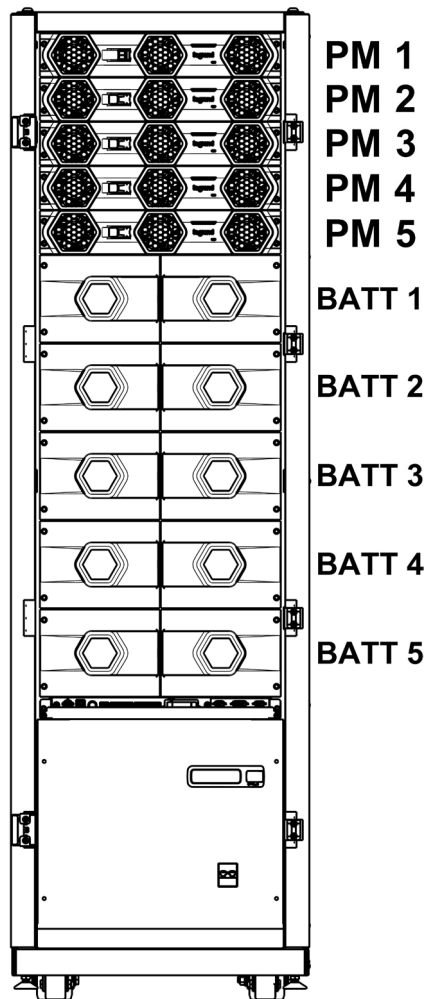

Starting from the top of the cabinet, insert two screwdrivers in the upper parts of the two plastic slot cover where the battery drawers must be installed. Slightly turn the screwdrivers down to unhook the covers.

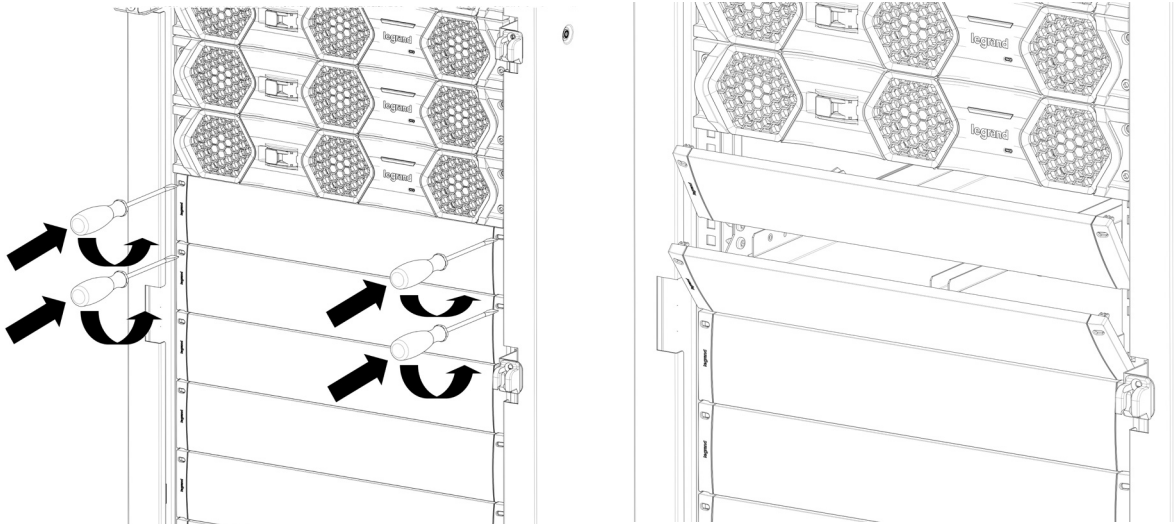

Insert the empty battery drawers in the free slots and push them till the 'click' of the safety block is heard. The battery packs must be added to the drawers only after the activation of the safety block.

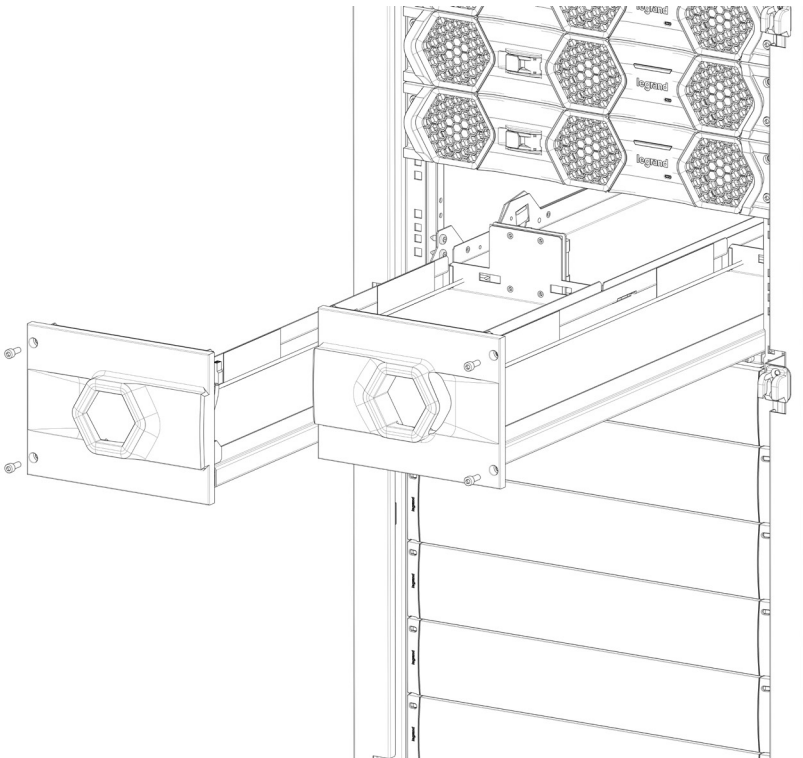

Remove the adhesive tape from the terminal covers at the extremes of the battery pack and remove the covers.

4. Installation

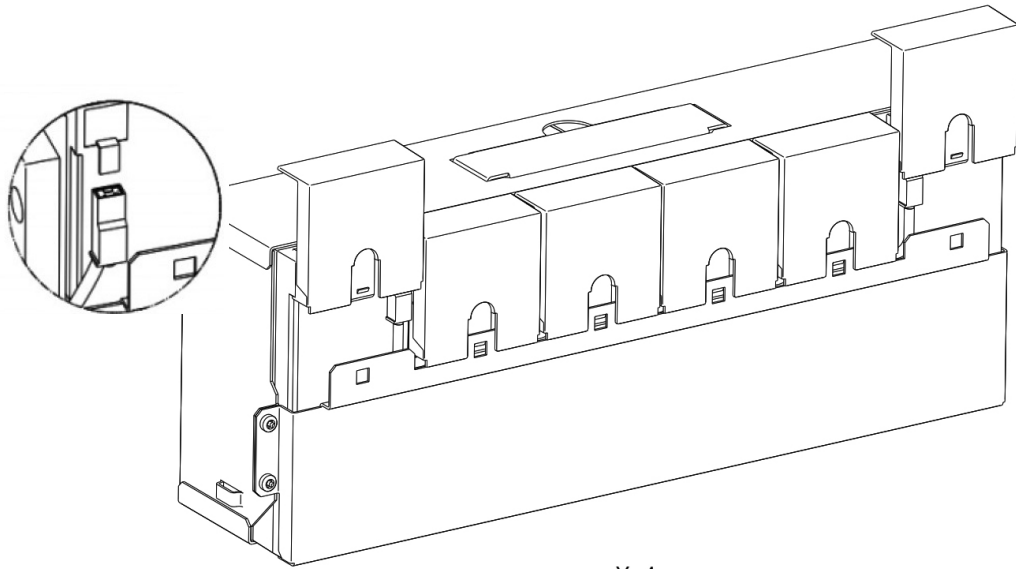

X 4

Add two battery packs on a drawer and connect in series the two packs using the provided cable fixed in the bracket and respecting the polarity (connect a positive terminal to a negative terminal).

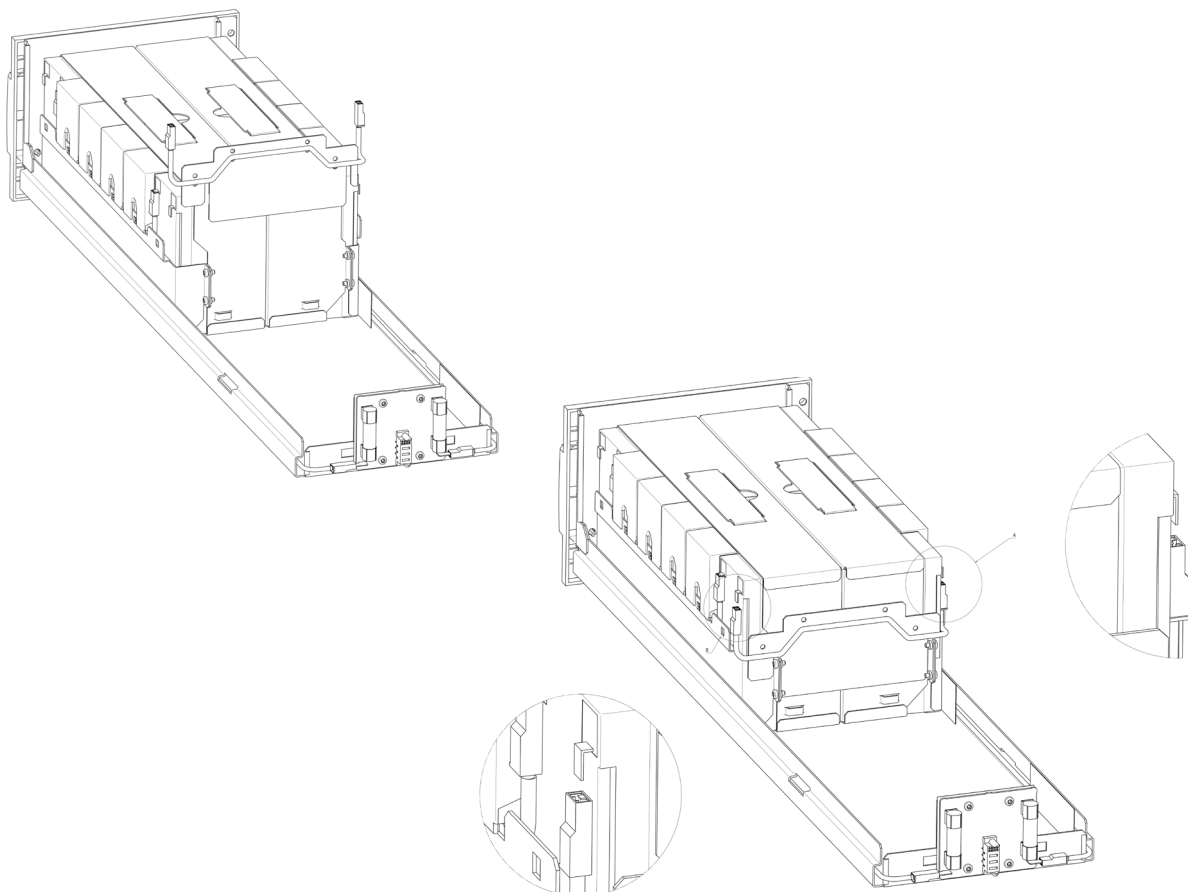

Connect the two provided cables on the free battery terminals that will connect the two battery packs with the other two that will be added in the next step. Insert the terminal covers and fix them to the packs with the adhesive tape.

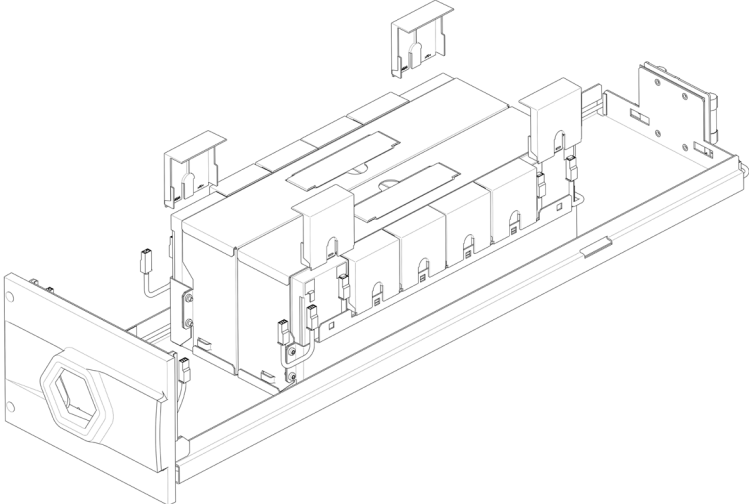

Add other two battery packs on the drawer.

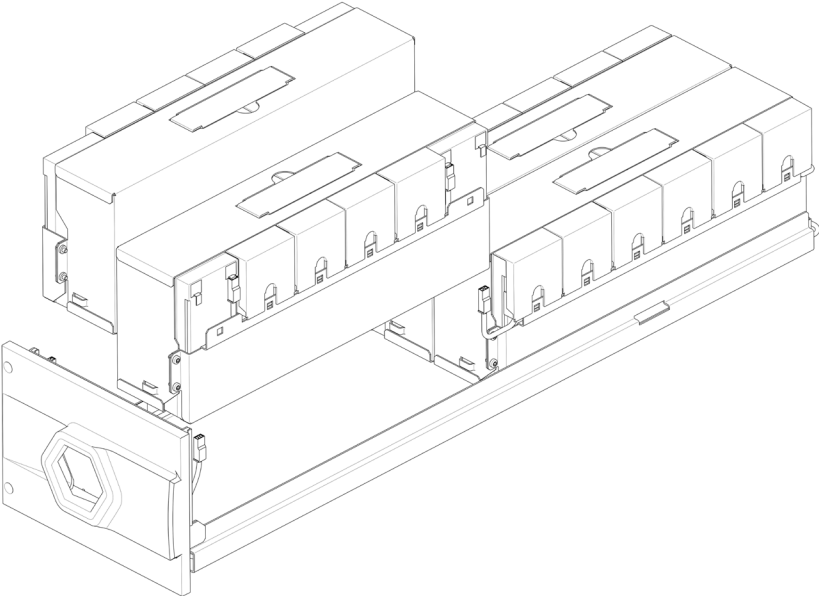

4. Installation

Connect in series the two new packs to the ones already in the drawer using the cable installed previously and respecting the polarity (connect a positive terminal to a negative terminal).

Connect the free terminals of the two batteries located close to the handle of the drawer to the cables that are connected to the back of the drawer. Check the correct polarity of the whole cabling.

Cables should not protrude from the drawer uprights to avoid cuts during insertion into the cabinet.

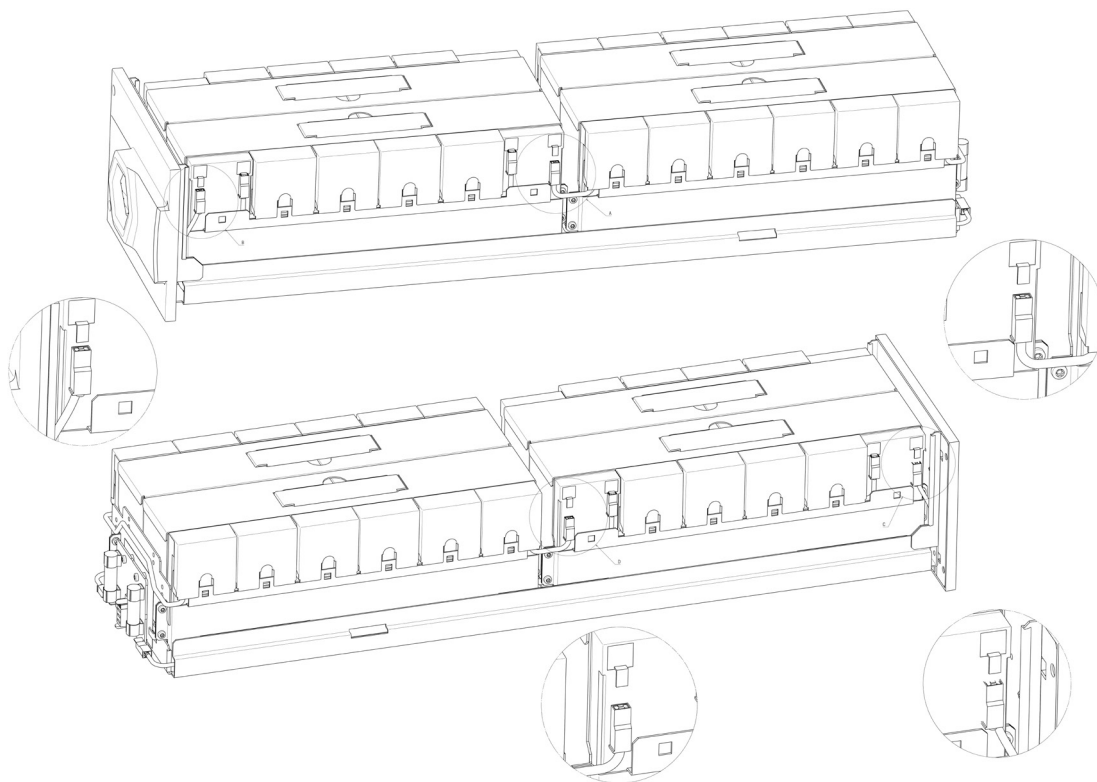

Insert the remaining terminal covers on the batteries and fix them with the adhesive tape to the battery pack.

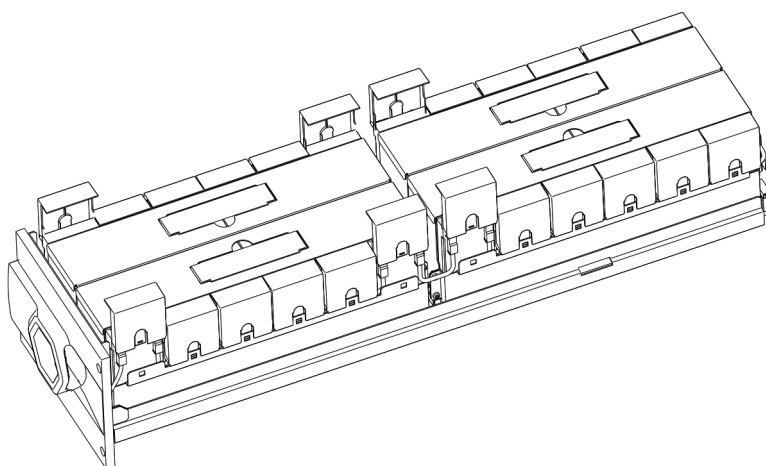

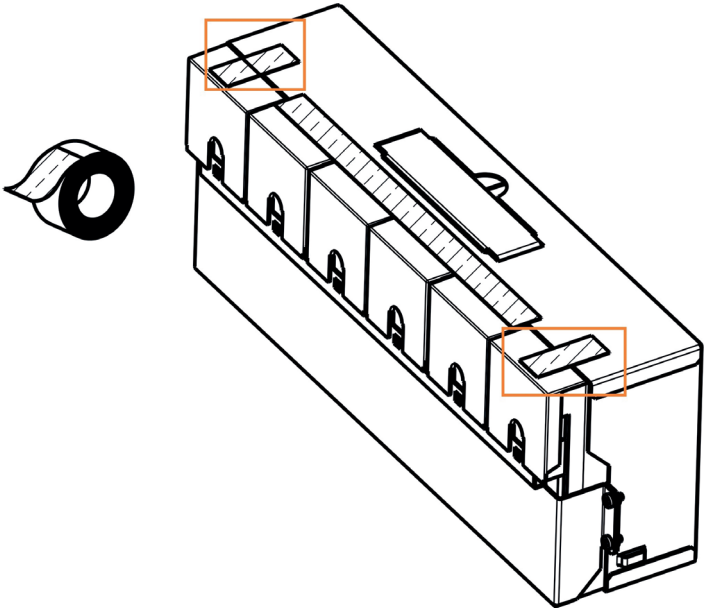

Fill the second drawer in the same way.
After the two drawers are ready, push them inside the UPS cabinet till they are abut and fix them with four screws included in the accessory kit.

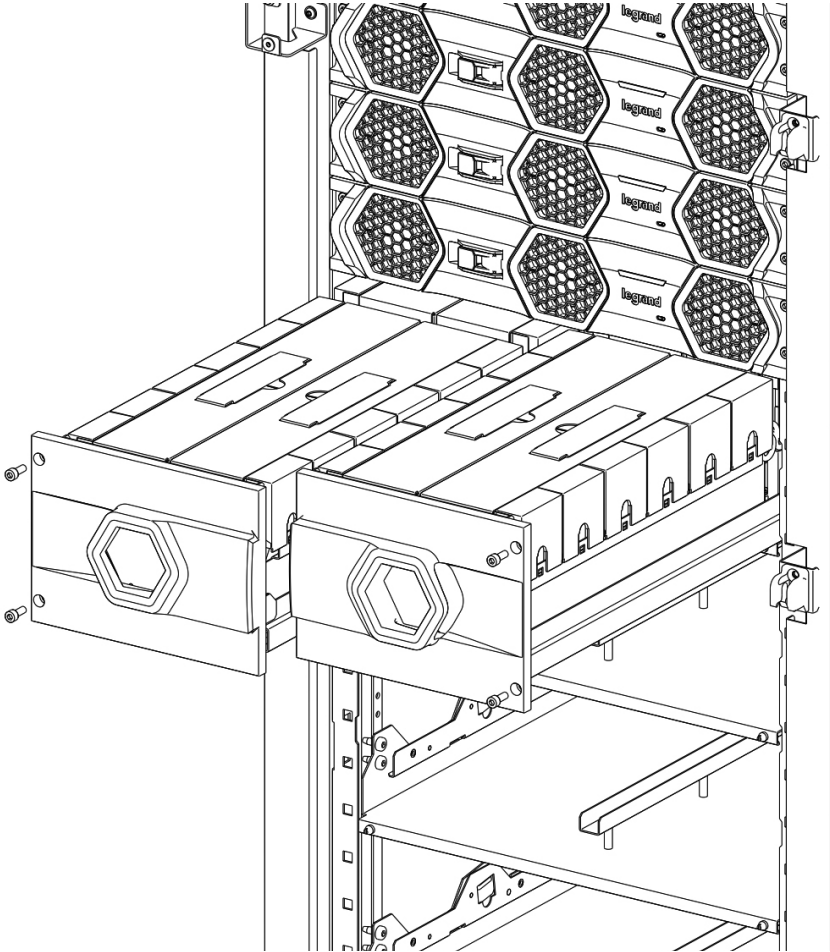

4. Installation



A drawer must be made up of batteries of the same brand and of the same manufacturing date.

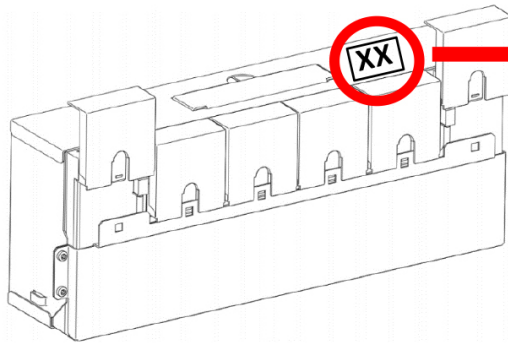

CHECK THE BATTERY CODE LABEL ON THE BATTERY BLOCK



XX	XX
XX	XX

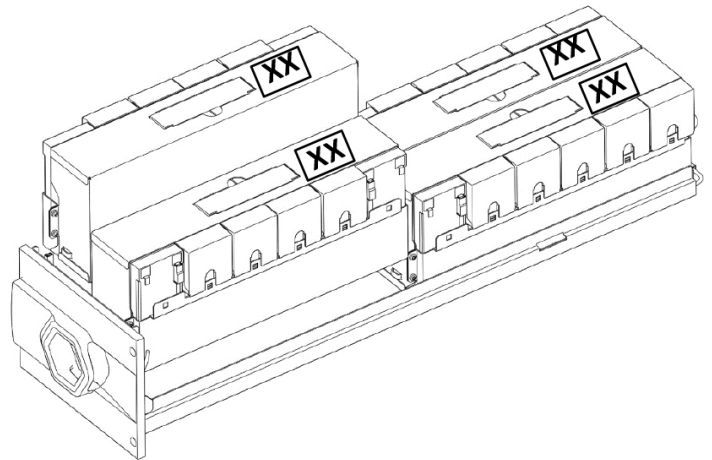

XX	YY
YY	XX

DO NOT MIX DIFFERENT BATTERY CODES ON THE SAME DRAWER!

4.5 SSS interface

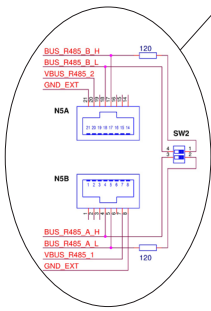
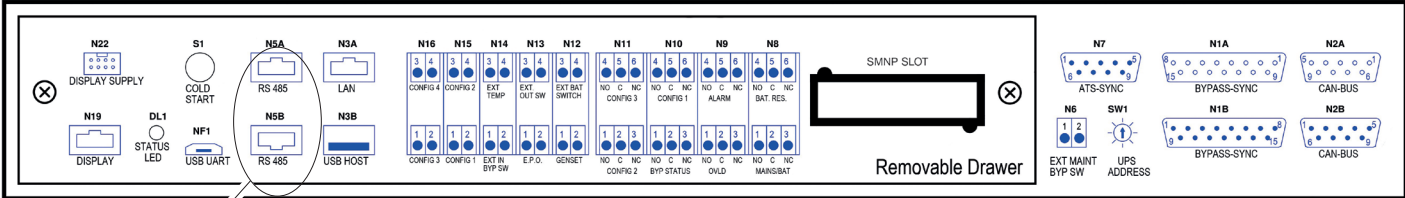

	TERMINAL	PINS	FUNCTION	
Analogic floating inputs	N16	1-2	CONFIGURABLE CONTACT 3 <i>(function not yet available)</i>	<p>Maximum input voltage: 15V 15 kΩ pull-up</p>
		3-4	CONFIGURABLE CONTACT 4 <i>(function not yet available)</i>	
	N15	1-2	CONFIGURABLE CONTACT 1 <i>(function not yet available)</i>	
		3-4	CONFIGURABLE CONTACT 2 <i>(function not yet available)</i>	
	N14	1-2	EXTERNAL BYPASS SWITCH <i>(function not yet available)</i>	
		3-4	EXTERNAL TEMPERATURE (maximum Input Voltage: 5V) It allows to check the temperature of the batteries for external cabinets. Use the Keor Mod battery temperature probe 3 104 82.	
Digital floating inputs	N13	1-2	EPO	<p>Maximum input voltage: 5V 1 kΩ pull-up</p>
		3-4	EXTERNAL OUTPUT SWITCH <i>(function not yet available)</i>	
	N12	1-2	GENSET It allows the UPS to know if there is an external generator.	
		3-4	EXTERNAL BATTERY SWITCH <i>(function not yet available)</i>	
Output contacts	N11	4-5-6	CONFIGURABLE CONTACT 3 <i>(function not yet available)</i>	<p>NC/NO contacts 30 Vdc -1 A 125 Vac - 0,5 A (resistive load).</p> <p>Dry Contact When the function is activated, the contact switches from the NC terminal to the NO terminal.</p>
		1-2-3	CONFIGURABLE CONTACT 2 <i>(function not yet available)</i>	
	N10	4-5-6	CONFIGURABLE CONTACT 1 <i>(function not yet available)</i>	
		1-2-3	BYPASS STATUS	
	N9	4-5-6	ALARM	
		1-2-3	OVERLOAD	
	N8	4-5-6	BATTERY AUTONOMY RESERVE	
		1-2-3	MAINS/BATTERY STATUS	
N6	1-2	AUXILIARY REMOTE BYPASS CONTACT It is possible to enable the bypass mode through this NO contact		

CONNECTOR	TERMINAL
N3B	USB HOST Port used for FW updates

The maximum wire cross sections that can be used for the SSS terminals is 1,5 mm².

4. Installation

4.5.1 Emergency Power Off (EPO)

The UPS has a contact that can be used to activate the immediate stop of the equipment. It can be set as normally closed (NC) or normally open (NO) from the user interface. The default configuration is NC.

The EPO terminal is found on pins 1 and 2 of contact N13 of the SSS interface.

Use a voltage-free contact to connect the epo externally.

INDICATION

It is not possible to connect in parallel the EPO circuits of several UPS. If necessary, use contacts on the EPO emergency pushbutton isolated from each other.

The electric characteristics of the EPO interface are:

- voltage between terminals 1 and 2 of contact N13 with open circuit: 5 Vdc
- current between terminals 1 and 2 of contact N13 with closed circuit: 5 mA

5. Configuration and start-up



DANGER

All the configurations and start-up operations must be carried out exclusively by a SKILLED TECHNICIAN (paragraph 2.2.1).

5.1 Pre-start-up checks

Before powering the equipment, carry out the following checks:

1. Close all the distribution panels on the UPS cabinet.
2. Check that the external mains input disconnecter is open (OFF position).
3. Check that the external bypass input disconnecter (if present) is open (OFF position).
4. Check that the external output disconnecter is open (OFF position).
5. Check that the battery disconnectors of the external battery cabinets (if present) are open.
6. Check that the maintenance bypass disconnecter and the output disconnectors of the UPS are open (OFF position).
7. Check that the input and output wiring has been done and that all the connections have been tightened up properly.
8. Check the correct phase sequence of the input and bypass line (if separate).
9. Check that the parameters (voltage and frequency) of the mains input are compatible with those shown on the UPS rating plate.
10. Check that all the power modules are inserted properly and that the fixing screws are screwed up to abut the relative slots (use hex socket M6x16 screws along with M6 toothed washers).
11. Check that all the battery drawers (if present) are inserted properly and that the fixing screws are screwed up to abut the relative slots (use hex socket M6x16 screws along with M6 toothed washers).
12. Check the presence of the EPO terminal according to the setting (see paragraph 4.5.1)

5.2 Start-up procedure

1. Insert the battery fuses into the appropriate fuse breakers of the external battery cabinets (if present).
2. Press for at least 5 seconds the COLD START button of the SSS interface. The display turns on and the UPS boot starts.
3. The UPS boot ends when the LEDs on the power modules turn to steady blue. Tap on the *Settings* icon of the menu bar at the bottom of the display.

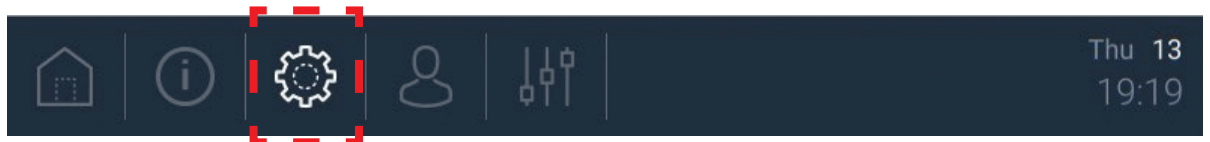

4. Choose the desired language in the tab *GENERAL* by tapping on the pencil icon on the item *Language*.

SYSTEM	GENERAL	ADVANCED	PM	BD
Reboot SSS		NO		
Language		ENGLISH (US)		
Display dimming		0		
Enable Buzzer		NO		
Cabinet Serial Number		123456789012		
HMI Language		ENGLISH		
Input Configuration EPO		ACTIVE LOW		
Input Configuration Ext. Battery Switch		ACTIVE LOW		
Input Configuration Genset		ACTIVE LOW		

5. Configuration and start-up

- Set the desired voltage and frequency output in the tab *SYSTEM* by tapping on the pencil icon on the items *Output Voltage* and *Output Frequency*.
In the same tab there is also the item *Enable or disable walk-in function*. If the UPS turns from battery mode to normal mode while it is connected to an external generator, especially with full load, there could be some frequency fluctuations causing a condition where the bypass is not available. If the walk-in function is enabled, the PM are not turned from battery mode to normal mode all together; they are turned to normal mode one by one with a time interval of 2 seconds. Tap on the pencil icon of the item *Enable or disable walk-in function* and select *ENABLE* or *DISABLE*.

SYSTEM	GENERAL	ADVANCED	PM	BD
Bypass Enable		YES		
Bypass Forced Mode		NO		
Output Frequency		50.00 HZ		
Operating Mode		ONLINE		
DIP Speed		FAST		
Synchro PLL Custom Range		1.000 Hz		
Synchro PLL Enable		YES		
Synchro PLL Range		STANDARD		
Output Voltage		230.0 V		

SYSTEM	GENERAL	ADVANCED	PM	BD
Bypass Forced Mode		NO		
Output Frequency		50.00 HZ		
Operating Mode		ONLINE		
DIP Speed		FAST		
Synchro PLL Custom Range		1.000 Hz		
Synchro PLL Enable		YES		
Synchro PLL Range		STANDARD		
Output Voltage		230.0 V		
Enable or disable walk-in function		ENABLE		

- 6. Select the tab BD to set the number of KB (Battery Kits) and the battery capacity in Ah of the single KB. Tap on the pencil icon of the item *Number of Kit Batteries installed* and insert the number of KB. Tap on the pencil icon of the item *Capacity value of Kit Batteries [Ah]* and insert the value of the battery capacity.

INDICATION

1 KB (Battery Kit) represents a string of 48 batteries in series. In case of models with internal battery drawers, 1 KB is made up of 2 drawers.

The UPS calculates the total battery capacity as produced by the total KB * Capacity.

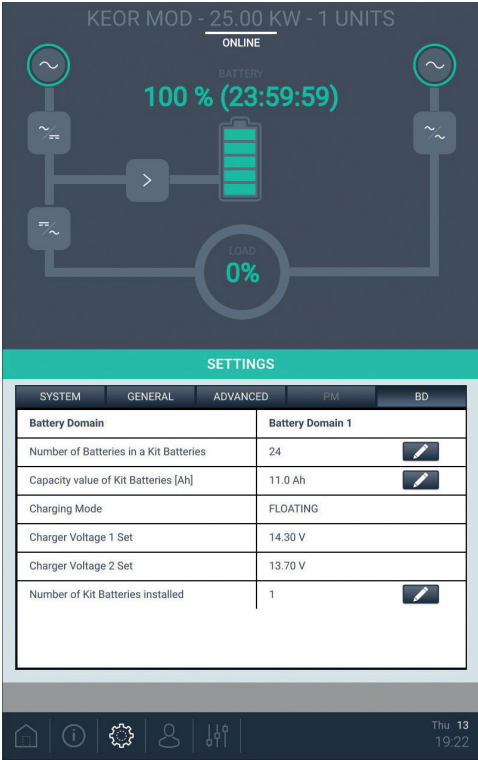

5. Configuration and start-up

7. In the *BD* tab, select the the charge mode of the UPS. There are 2 modes available:
 - Floating mode: the voltage on the batteries is maintained to 13.8 V. For this mode it is also possible to have a tune of the charging voltage according to the temperature detected by an internal sensor of the SSS (in case of internal battery drawers) or through an external sensor (in case of external battery cabinets).
 - 2 step mode: smart charge with an advanced cycle that limits any chance of overcharging or overheating the batteries.
 Tap on the pencil icon of the item *Charging Mode* and choose between these 4 options: *TWO STEP*, *FLOATING*, *FLOATING_INT* and *FLOATING_EXT*.
 The last two options refer to the floating mode with internal or external temperature control.

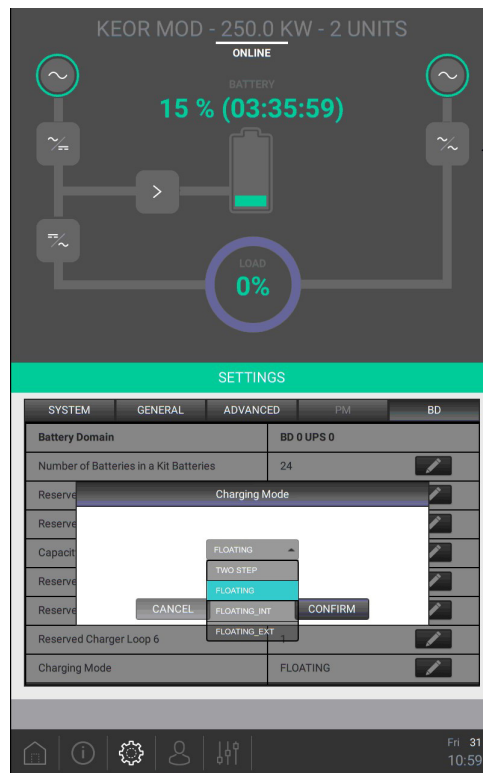

8. Set the configuration of the batteries (see paragraph 4.2.10) by tapping on the *General Commands* icon of the menu bar at the bottom of the display.



9. Tap on the icon > of the item *BATTERY CONFIGURATION*.

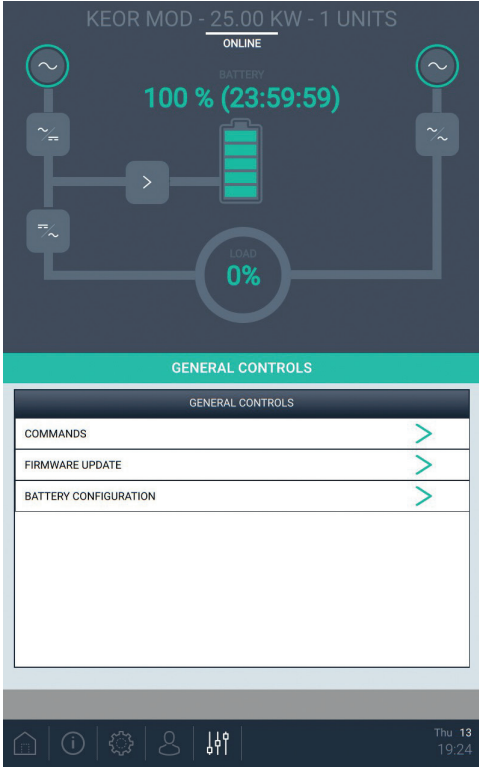

10. Select the type of Battery Configuration among the three options:
- *Common*: all the strings of batteries are in common;
- *Cabinet*: each UPS unit has his unique battery cabinet;
- *Individual*: each PM is connected to a unique battery string.

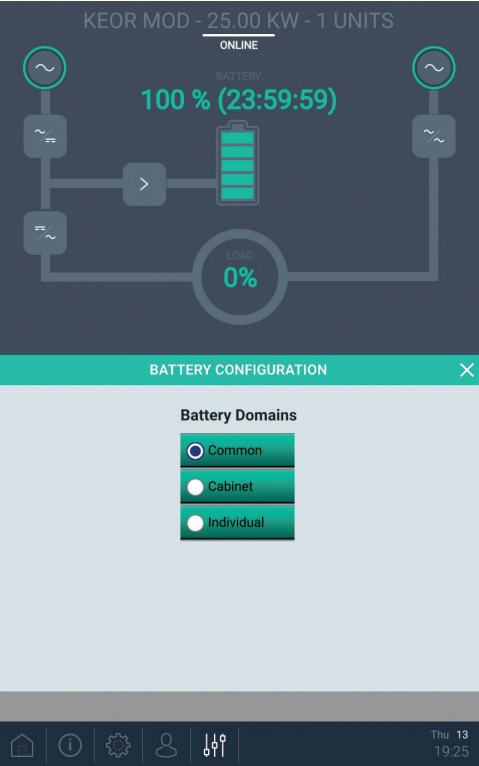

5. Configuration and start-up

11. If there are two Keor MOD systems connected to an STS (see paragraph 4.2.12), it is necessary to set a proper configuration for one of the UPS in each system.

Tap on the *Settings* icon of the menu bar at the bottom of the display. Select the *System* tab.

Tap on the pencil icon of the item Syncro2N Mode. If the UPS is part of the system which is the primary source of supply to the load through the STS, select MASTER. If the UPS is part of the secondary system which is the alternative source, select SLAVE.

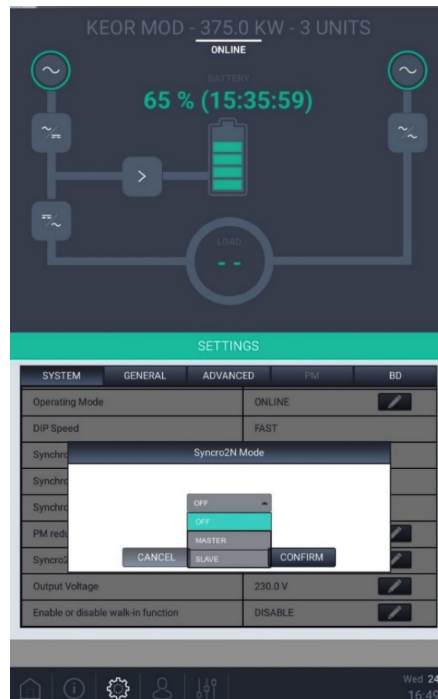

12. Provide the mains supply to the UPS by closing the external mains input/bypass input disconnectors (ON position).

13. Ensure that the EPO is connected to the SSS interface (the default setting is NC).

Tap on the *General Commands* icon of the menu bar at the bottom of the display. Find the item *System Power On* and tap on the button *ON* to turn on the UPS.

14. The LEDs on the power modules turn to steady yellow while they are powered from the batteries. When they are powered from the mains and the UPS is on-line, the LEDs turn to steady green.

15. Check that the output voltage and frequency values set correspond with the requirements of the load. If not, turn off the UPS and set the correct values (see step 6).

16. Provide the power supply to the load by closing the external output disconnector (ON position).

17. Close the UPS door and remove the key.

DANGER

Do not remove the power modules during the functioning of the UPS without activating the hot-swap procedure (described in paragraph 6.3.1). The removal of one or more power modules without the proper use of the hot-swap procedure could damage the equipment.

CAUTION

The keys to open the UPS door and the installation manual must not be left at the disposal of the operator.

5.3 Turning off the UPS

Follow this procedure in case there is the need to turn off the UPS:

1. Tap on the *General Commands* icon of the menu bar at the bottom of the display.
2. Then locate the item *System Power Off* and tap on the button *OFF* to turn off the UPS.

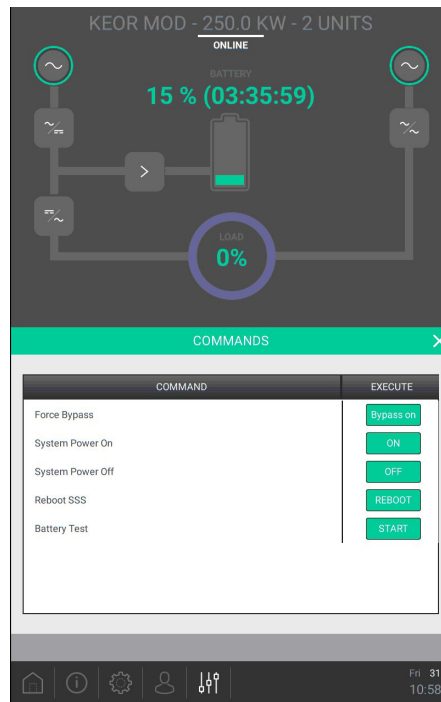

3. The LEDs on the power modules turn to steady blue when they are in stand-by mode and the UPS is no longer supplying the load.

DANGER

In this stand-by condition there are still hazardous voltages on the UPS.

To disconnect the UPS from all sources of supply:

- open the external mains input/bypass input disconnectors (ON position);
- open all the fuse breakers of the external battery cabinets (if present);
- remove at least one battery drawer for every shelf present to interrupt the battery string.

6. Maintenance



DANGER

INSTALLATION and ORDINARY MAINTENANCE operations must be carried out only by SKILLED TECHNICIANS (paragraph 2.2.1).

EXTRAORDINARY MAINTENANCE operations must be carried out only by LEGRAND TECHNICAL SUPPORT SERVICE. LEGRAND declines all liability for any injury or damage caused by activities carried out differently from the instructions written in this manual.

6.1 Preventive maintenance

The UPS does not contain parts for preventative maintenance by the operator.

The operator must regularly perform:

- a general external cleaning;
- a check to verify there is no alarm indication on the display;
- a check to verify the correct functioning of the ventilating fans on each power module.

6.2 Periodical checks

The correct functioning of the UPS must be guaranteed by periodical maintenance inspections. These are essential to safeguard the reliability of the equipment.

These inspections should also be made to determine if components, wiring, and connections exhibit evidence of overheating.

During a maintenance inspection, the skilled technician must carry out the following checks:

- no alarm presence;
- list of the memorised events;
- correct function of the static and maintenance bypass;
- integrity of the electrical installation;
- flow of cold air;
- battery status;
- characteristics of the applied load;
- conditions of the installation location.

Contact the LEGRAND Technical Support Service in case of problems.



WARNING

The periodical checks involve operations inside the UPS in presence of dangerous voltages. Only maintenance personnel trained by LEGRAND are authorized to intervene.

It is also possible to perform an automatic battery test. With this function, only one PM is switched to battery mode to verify the battery status.

Tap on the *General Commands* icon of the menu bar at the bottom of the display. Find the item *Battery Test* and tap on the button *START*.

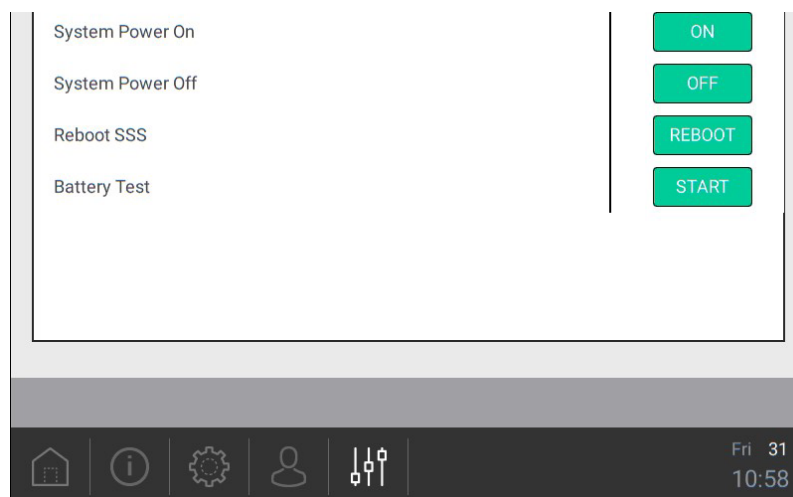

CAUTION

Do not power off the UPS during a battery test.

6.3 Ordinary maintenance

6.3.1 Hot-swap procedure for the replacement of power modules

The hot-swap procedure makes it possible to replace a faulty power module while the load is powered by the UPS in on-line mode. In case of a black-out during the procedure, there is no risk to power off the load since it is supplied by the other power modules.

INDICATION

To use this function, the UPS must have at least two power modules and the output power required must not be above the one available during the hot-swap procedure.

Always replace just one PM at a time.

If the load power does not allow the hot-swap without overload, perform the manual bypass mode maintenance procedure.

Each power module (PM) is identified by a unique address inside the system, as shown below:

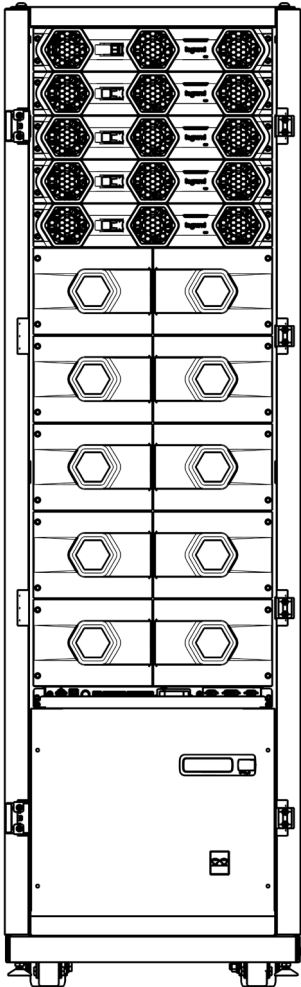

- PM 1
- PM 2
- PM 3
- PM 4
- PM 5

KEOR MOD 125

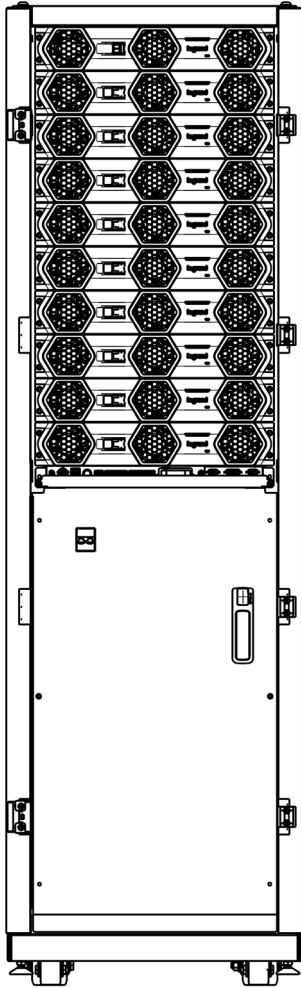

- PM 1
- PM 2
- PM 3
- PM 4
- PM 5
- PM 6
- PM 7
- PM 8
- PM 9
- PM 10

KEOR MOD 250

6. Maintenance

During the hot-swap procedure the maximum active power available is indicated in the following table:

	MAXIMUM ACTIVE POWER AVAILABLE
KEOR MOD 50	25 kW (50%)
KEOR MOD 75	50 kW (66%)
KEOR MOD 100	75 kW (75%)
KEOR MOD 125	100 kW (80%)
KEOR MOD 150	125 kW (84%)
KEOR MOD 175	150 kW (86%)
KEOR MOD 200	175 kW (88,5%)
KEOR MOD 225	200 kW (89%)
KEOR MOD 250	225 kW (90%)

The following is the hot-swap procedure:

1. Check that the load connected to the UPS allows the power module replacement without causing an overload.
2. Open the frontal switch of the PM that must be replaced. When the frontal switch is open, it is not possible to restart the PM by simply closing it. It is necessary to extract the PM.

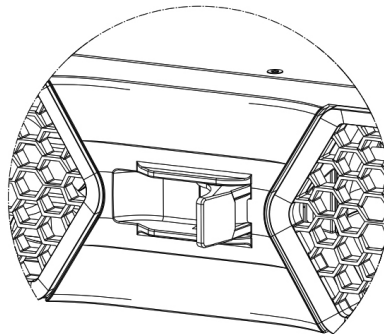

3. Initially, the LED on the PM turns blue. Wait until it turns white: the PM is ready to be replaced.
4. Unscrew the fixing screws of the PM and save them.
5. Extract the PM until the safety block prevents the extraction from continuing.

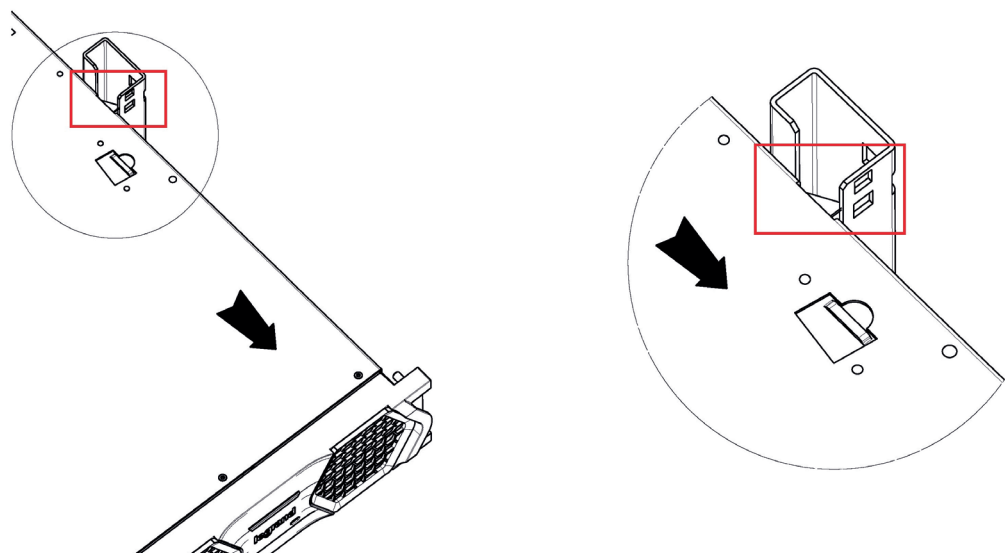

6. Push the safety hook located on the top right of the PM to unlock the block and pull the PM to finalize the extraction.

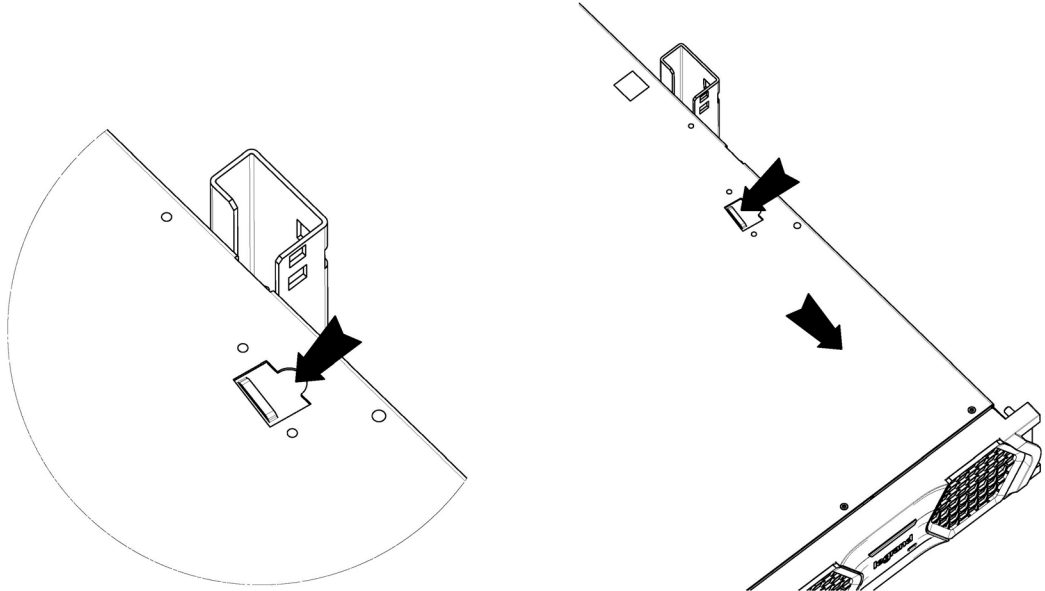

7. Insert the new PM on the free slot making sure that the frontal switch is open and that the module is in abutment.
8. Fix the PM to the cabinet using the screws previously unscrewed.
9. Close the frontal switch of the PM.

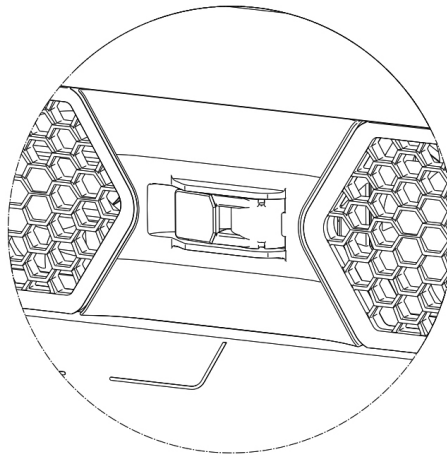

10. The LED on the PM turns red. After the boot of the PM, the LED turns blue. Next, the PM starts in battery mode (yellow LED). Finally, the LED turns green and the PM is powered by the mains.

INDICATION

If one or more screws are lost, use only hex socket M6x16 screws along with M6 toothed washers to fix the power modules.

CAUTION

If there is a hot-swap replacement of a PM and the UPS battery charger status was set to OFF, it is important to verify its status at the end of the procedure. If the charger has turned on, it is necessary to change the status to OFF.

6. Maintenance

6.3.2 Installation/replacement of power modules with the UPS in maintenance bypass mode

If the hot-swap procedure explained in the previous paragraph is not applicable, it is possible to replace or even to add PM with the UPS in maintenance bypass mode.

INDICATION

During this procedure, the load is not protected by the UPS because it is powered from the bypass input line.

6.3.2.1 Setting the UPS in maintenance bypass mode

1. Tap on the *Settings* icon of the menu bar at the bottom of the display.



2. Check on the tab *System* that the item *Bypass Enable* is set to YES. If not, tap on the item and enable the bypass.

KEOR MOD - 25.00 KW - 1 UNITS
ONLINE
BATTERY 100 % (23:59:59)
LOAD 0%

SETTINGS

SYSTEM	GENERAL	ADVANCED	PM	BD
Bypass Enable		YES		
Bypass Forced Mode		NO		
Output Frequency		50.00 HZ		
Operating Mode		ONLINE		
DIP Speed		FAST		
Synchro PLL Custom Range		1.000 Hz		
Synchro PLL Enable		YES		
Synchro PLL Range		STANDARD		
Output Voltage		230.0 V		

Thu 13 19:21

3. Tap on the *General Commands* icon of the menu bar at the bottom of the display.



4. Tap on the icon > of the item *COMMANDS*.

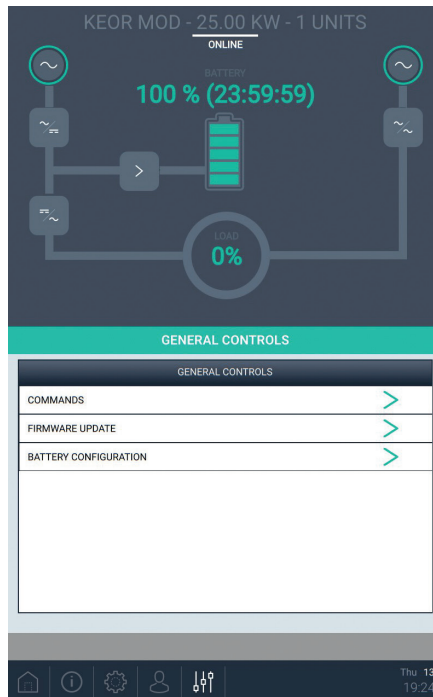

5. Tap on the *Bypass on* button of the item *Force Bypass*. The LEDs of the PM blink fast in orange.

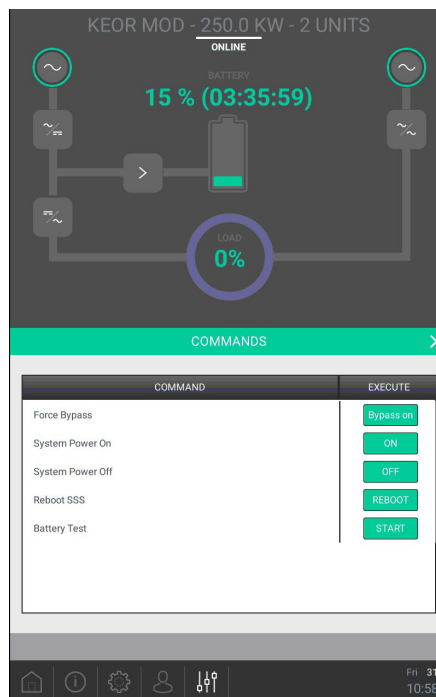

6. Maintenance

6. Close the maintenance manual bypass switch by bringing it to the ON position. The load is powered directly from the bypass line.
7. Turn OFF the UPS by following the procedure described at paragraph 5.3. The LEDs of the PM turn to blue when the PM are in stand-by mode.
8. If present, open the battery disconnectors of the external battery cabinets.



DANGER

If there are battery drawers installed in the cabinet, some internal parts of the UPS are still live with dangerous voltage. Remove at least one battery drawer for every shelf present to interrupt the battery string.

6.3.2.2 Installation/replacement of power modules

Check that the procedure for setting the maintenance bypass mode described in paragraph 6.3.2.1 has been applied.

To replace a PM:

1. Open the frontal switch of the PM to be replaced.

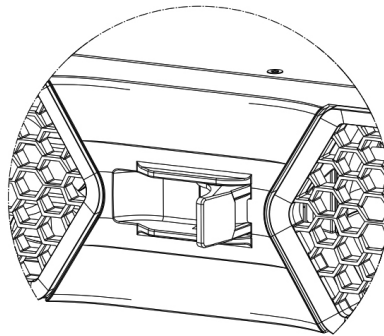

2. Unscrew the fixing screws of the PM and save them.
3. Extract the PM until the safety block prevents to continue the extraction.

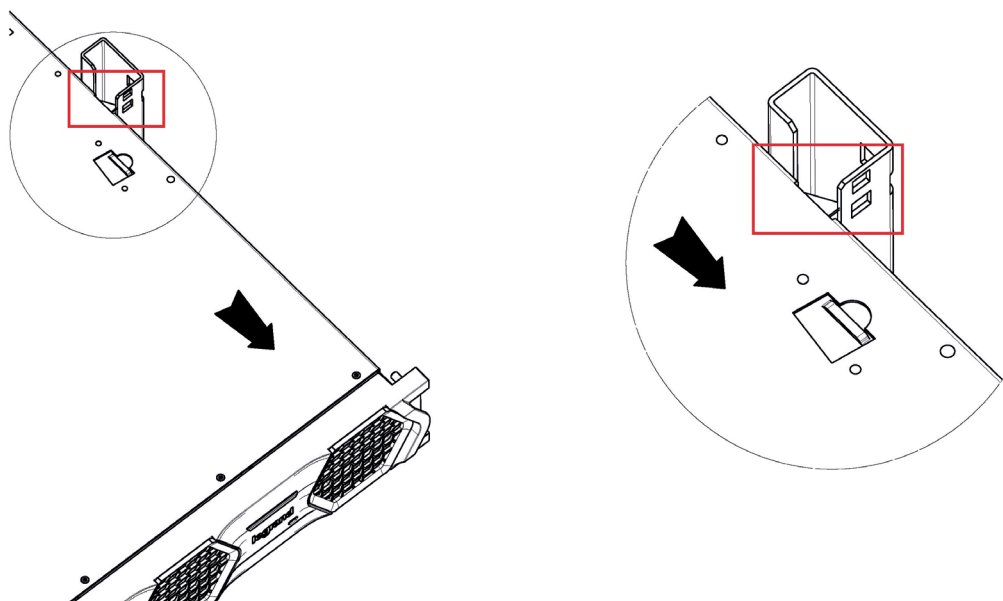

4. Push the safety hook located on the top right of the PM to unlock the block and pull the PM to finalize the extraction.

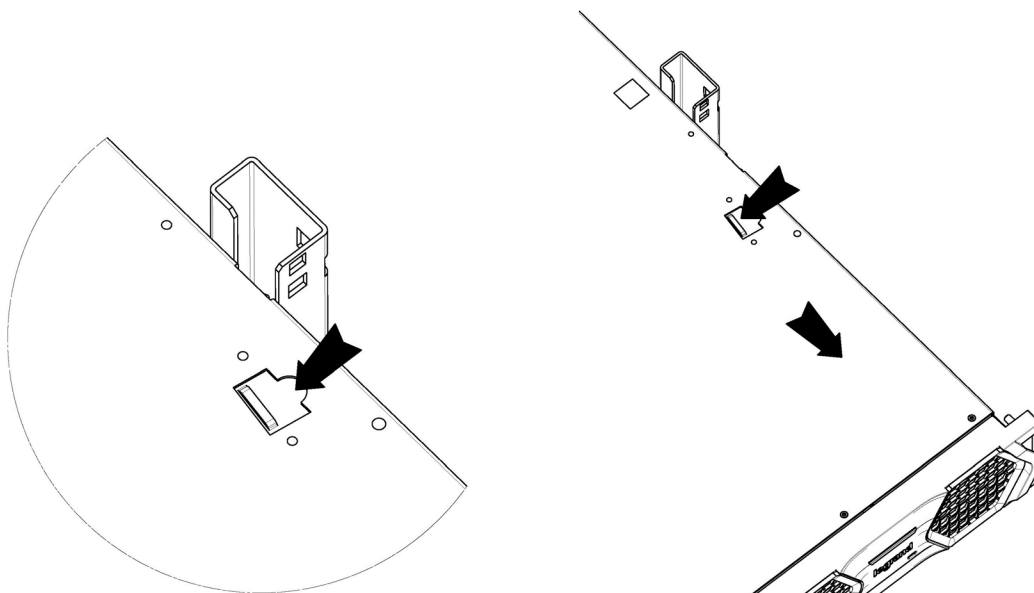

5. Insert the new PM on the free slot making sure that the frontal switch is open and that the module is in abutment.
6. Fix the PM to the cabinet using the screws previously unscrewed.
7. Close the frontal switch of the PM and wait until the LED of the PM turns blue.

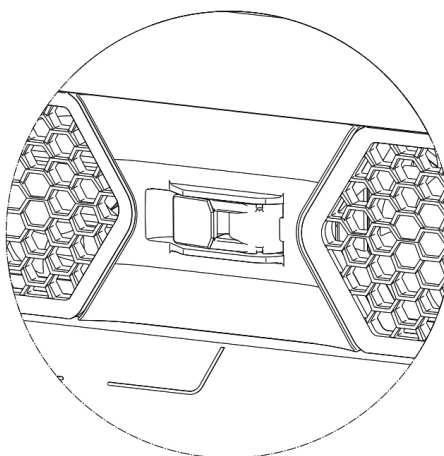

To add a PM:

1. Unscrew the screws of the protective cover of a free slot starting from the top of the cabinet.
2. Insert the new PM on the free slot making sure that the frontal switch is open and that the module is in abutment.
3. Fix the module using the screws previously unscrewed.
4. Close the frontal switch of the PM.

INDICATION

If one or more screws are lost, use only hex socket M6x16 screws along with M6 toothed washers to fix the power modules.

6. Maintenance

6.3.2.3 Exit the UPS from the maintenance bypass mode

1. If present, close the battery disconnectors of the external battery cabinets and insert all the internal battery drawers.
2. Tap on the *General Commands* icon of the menu bar at the bottom of the display. Find the item *System Power On* and tap on the button *ON* to turn on the UPS.

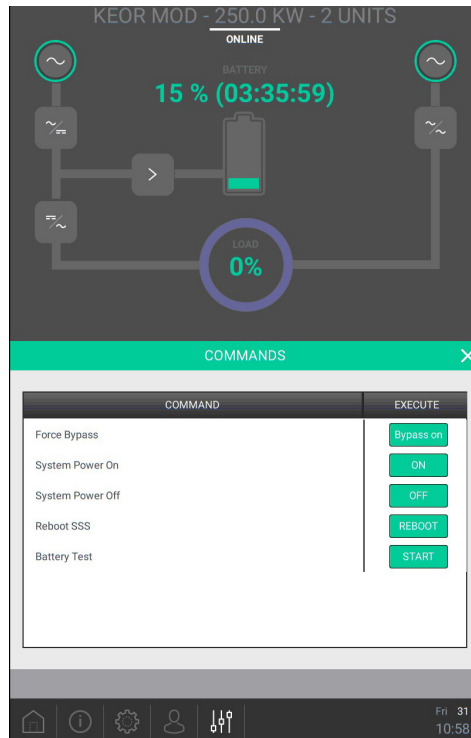

3. Wait for the UPS boot until the LEDs of the PM blink fast in orange.
4. Open the maintenance manual bypass switch by bringing it to the OFF position
5. Tap on the *General Commands* icon of the menu bar at the bottom of the display. Tap on the icon > of the item *COMMANDS*. Tap on the *Bypass off* button of the item *Force Bypass*. The LEDs of the PM turn to steady green.

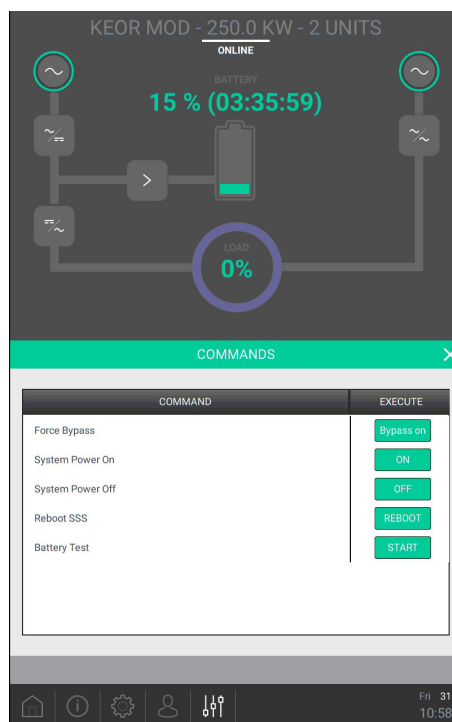

6.3.3 Removal of the SSS drawer

1

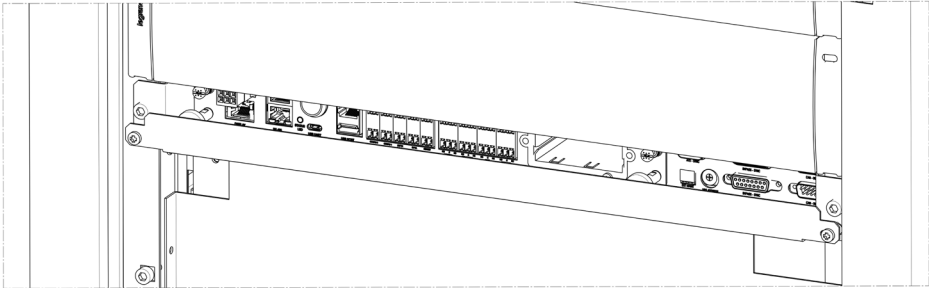

2

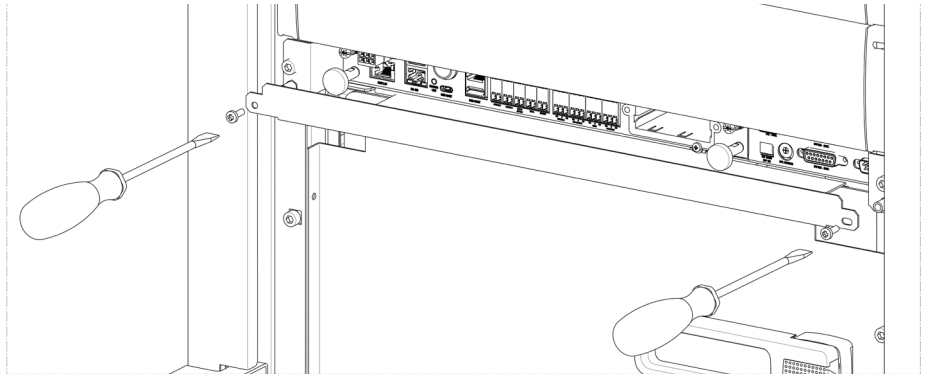

3

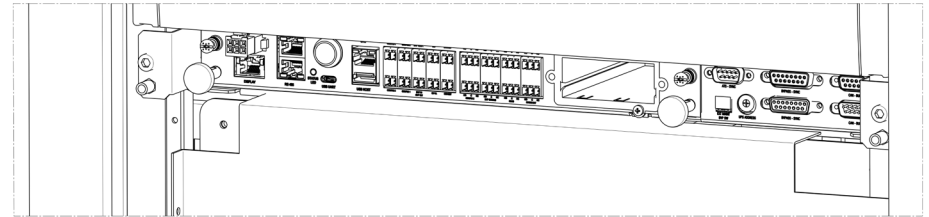

4

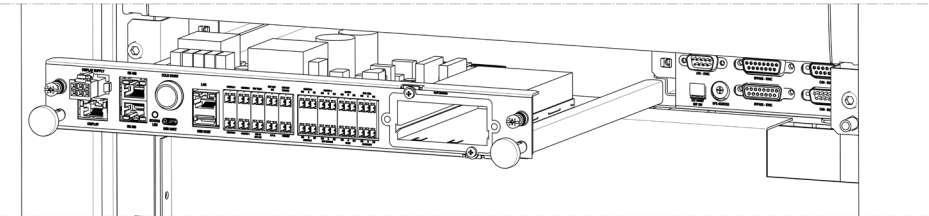

6. Maintenance

6.4 Battery drawers replacement



WARNING

A battery can present a risk of electrical shock and high short circuit current. Read and apply the safety instructions in chapter 2 before operating on batteries

INDICATION

The battery drawers must always be added/removed in multiples of two (1 KB consists of two battery drawers). Always replace just one KB at a time. If one KB is added, start from the free slots at the top which are covered by protective covers. If a KB is completely removed, install the protective covers to block any access to live parts. If the installation/removal procedure changes the total number of KB installed in the UPS, it is necessary to update this setting from the control panel.



CAUTION

A drawer must be made up of batteries of the same brand and of the same manufacturing date.

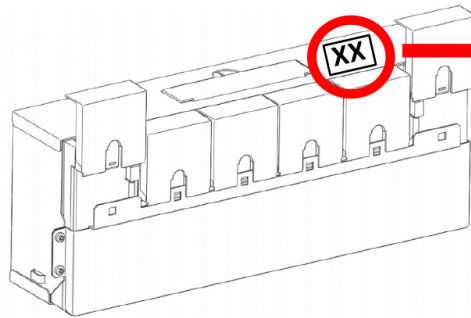

CHECK THE BATTERY CODE LABEL ON THE BATTERY BLOCK



XX	XX
XX	XX

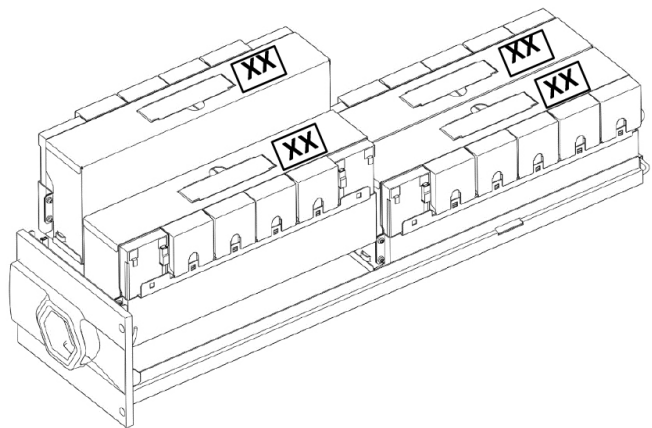

XX	YY
YY	XX

DO NOT MIX DIFFERENT BATTERY CODES ON THE SAME DRAWER!

6.4.1 Installation/replacement of battery drawers with UPS in on-line mode

To replace a battery drawer:

1. Check that the UPS has installed more than 1KB every 25kVA of power supplied to the output.
2. Check that the UPS is not working in battery mode and that the battery charger is in the "maintenance" or "standby" state.
3. Extract the battery drawer until the safety block prevents to continue the extraction.

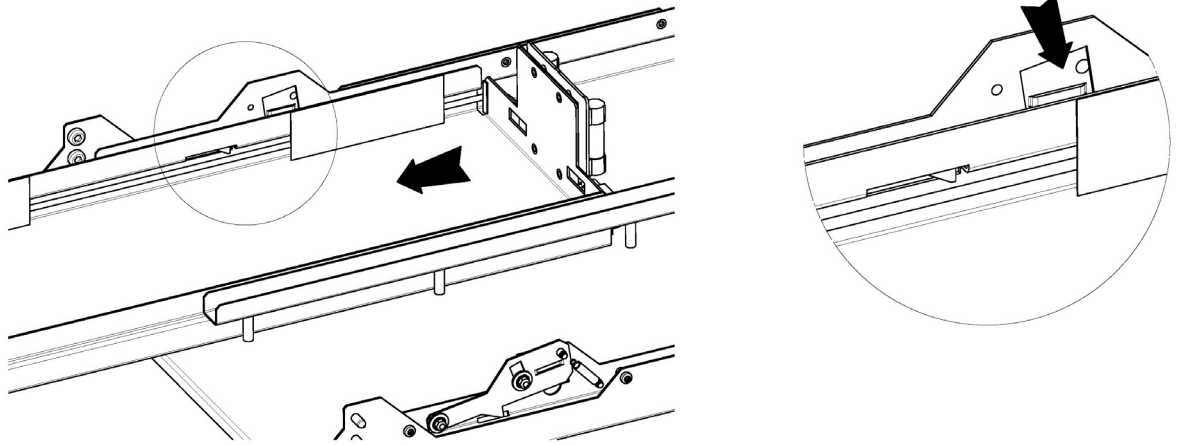

4. Remove all the battery packs from the drawer. Use the handle included in the accessory kit to remove the battery packs at the back of the drawer.

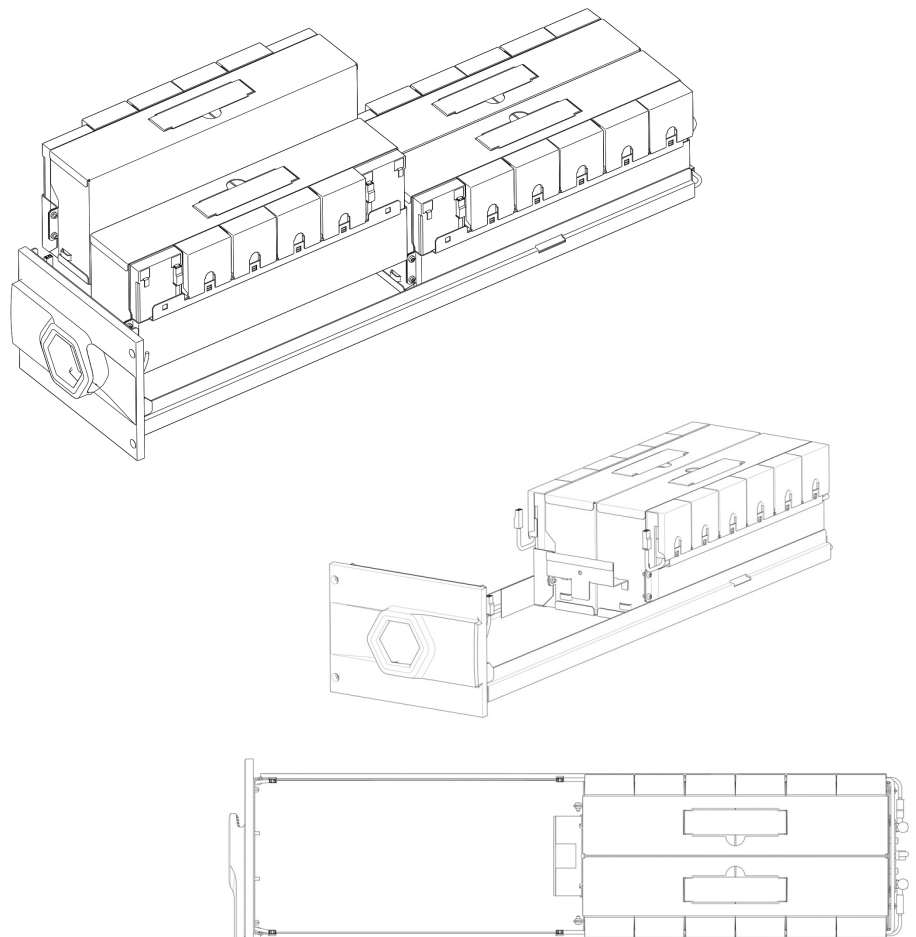

6. Maintenance

5. Push up the safety hook located on the left side of the battery drawer to unlock the block and pull the drawer to finalize the extraction.

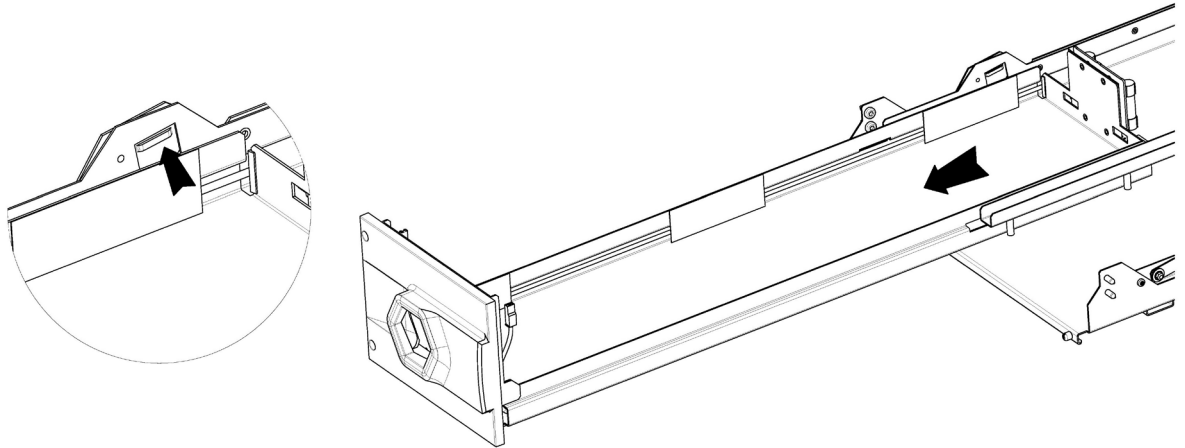

6. Follow the procedure shown at paragraph 4.4 to insert a new battery drawer

INDICATION

If the UPS turns to battery mode during these operations, do not continue the installation/replacement. It is possible to resume the operations when the UPS turns to on-line mode.

When there is a black-out during the replacement of battery drawers, the backup time is reduced. It is necessary to carefully assess this event before starting with the installation/replacement procedure.

To add a battery drawer:

Follow the procedure shown at paragraph 4.4 to add a new battery drawer

6.4.2 Installation/replacement of battery drawers with UPS in maintenance manual bypass

To replace a battery drawer:

1. Follow the procedure described in paragraph 6.3.2.1 for setting the UPS in maintenance bypass mode.
2. Extract the battery drawer until the safety block prevents to continue the extraction.

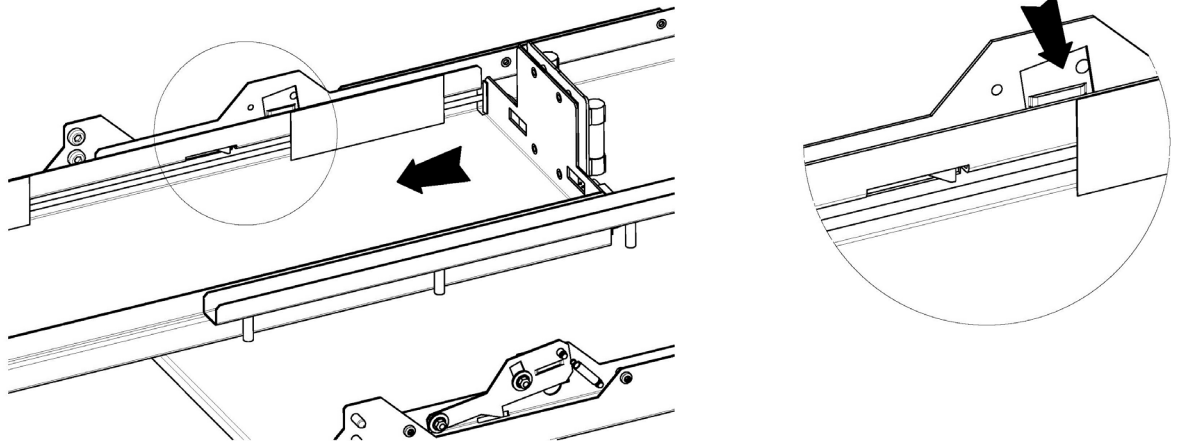

3. Remove all the battery packs from the drawer. Use the handle included in the accessory kit to remove the battery packs at the back of the drawer.

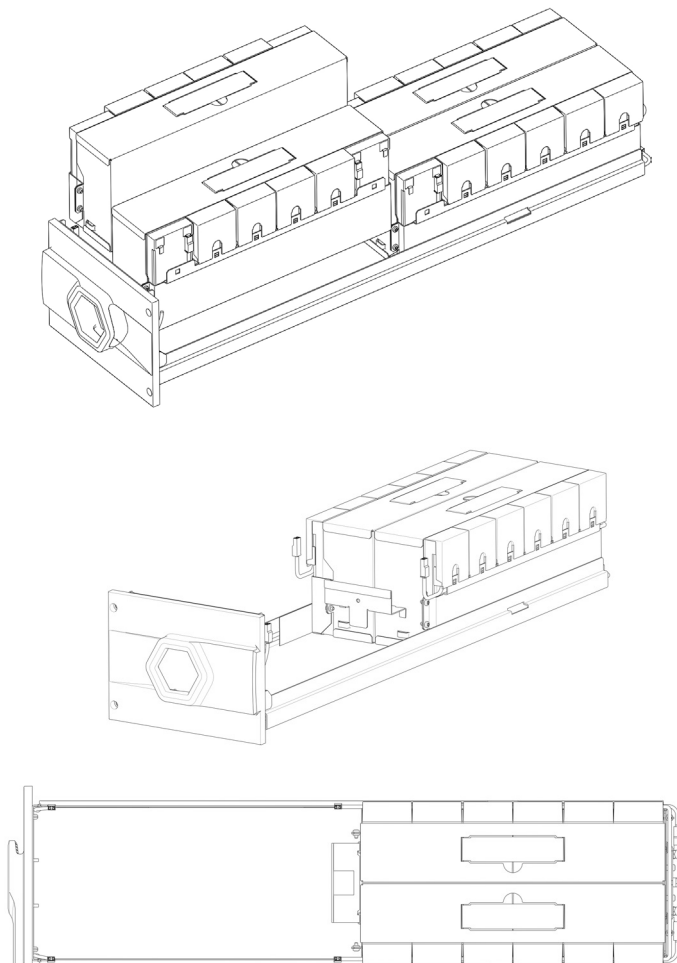

6. Maintenance

4. Push up the safety hook located on the left side of the battery drawer to unlock the block and pull the drawer to finalize the extraction.

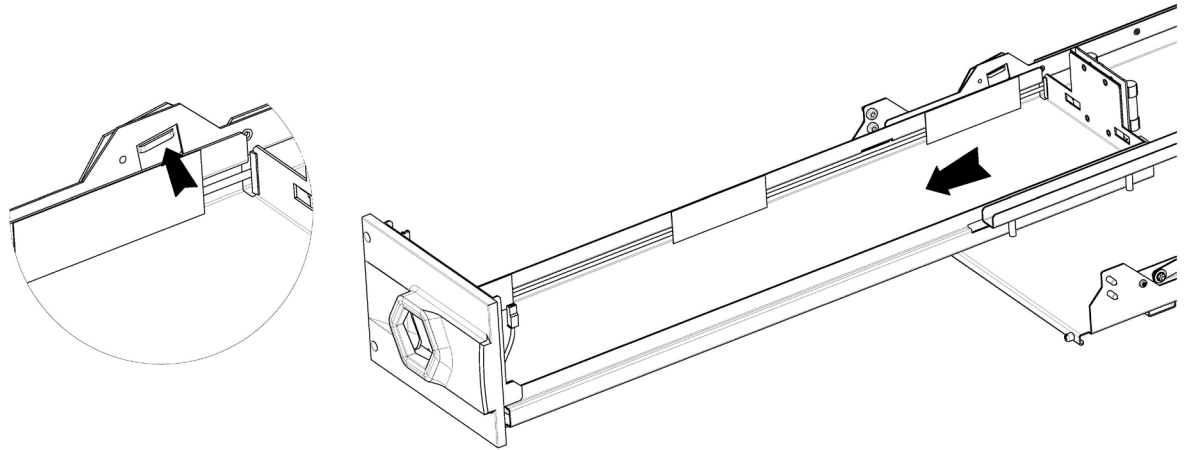

5. Follow the procedure shown at paragraph 4.4 to insert a new battery drawer
6. Follow the procedure described in paragraph 6.3.2.3 to exit from the maintenance bypass mode.

To add a battery drawer:

1. Follow the procedure described in paragraph 6.3.2.1 for setting the UPS in maintenance bypass mode.
2. Follow the procedure shown at paragraph 4.4 to add a new battery drawer
3. Follow the procedure described in paragraph 6.3.2.3 to exit from the maintenance bypass mode.

INDICATION

During the installation/replacement operations, the load is not protected by the UPS because it is powered from the bypass input line.

6.5 Replacing the fuses and surge arrester (DIN rail)

A surge arrester and two fuse holders can be found in the DIN rail inside the cabinet. It is not necessary to open the front panel for the replacement.

The first fuse holder contains a 16A GG 10x38mm fuse (LG-013316). It is in series to the surge arrester.

The second fuse holder contains a 2A GG 10x38mm fuse (LG-013302). It is in series to the input bypass disconnecter release coil.

The surge arrester is a T2 40kA 1P SPD (LG-412230).

INDICATION

It is mandatory to verify monthly the indication on the surge arrester. The device works correctly if the indicator is green. If the device is damaged, the indicator is red and the surge arrester must be replaced.

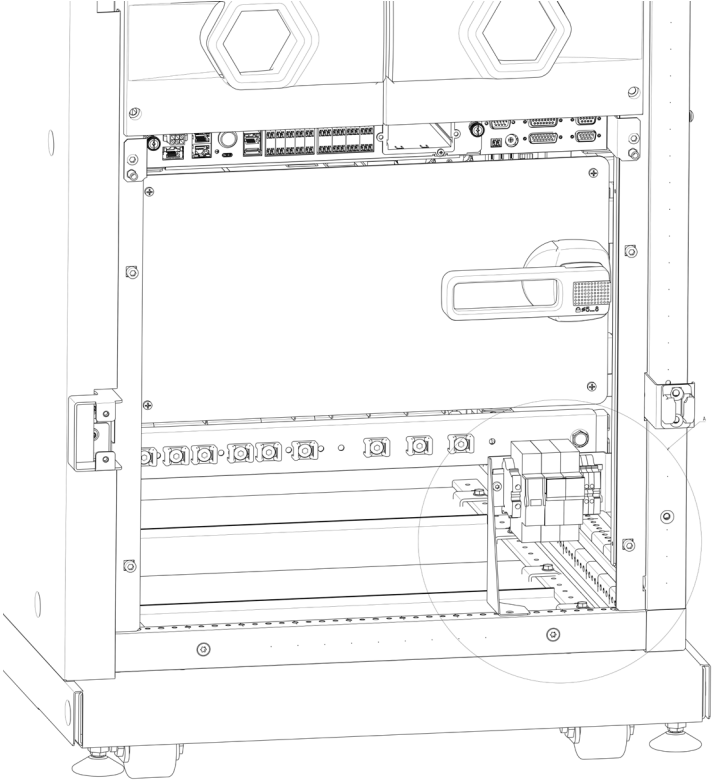

T2 40kA 1P SPD
 16A GG 10x38mm fuse
 2A GG 10x38mm fuse

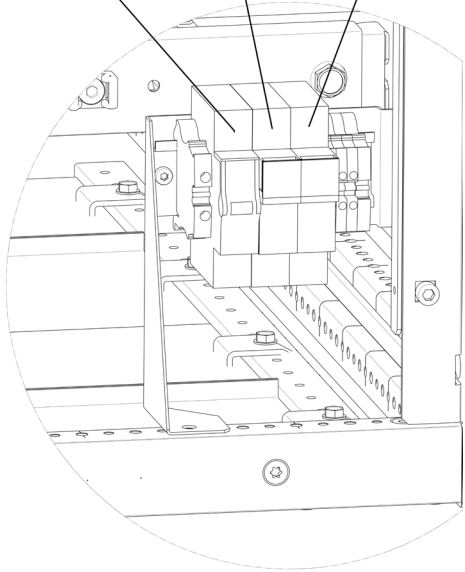

KEOR MOD 125

T2 40kA 1P SPD
 16A GG 10x38mm fuse
 2A GG 10x38mm fuse

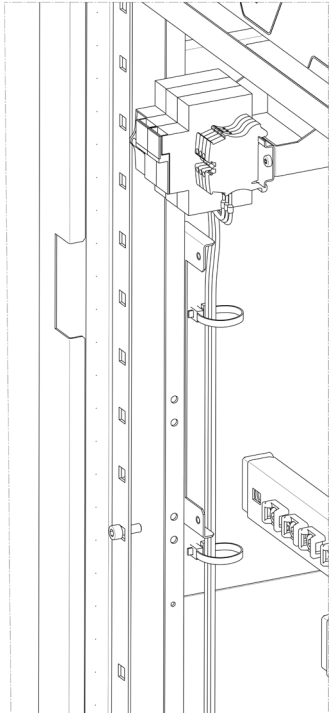
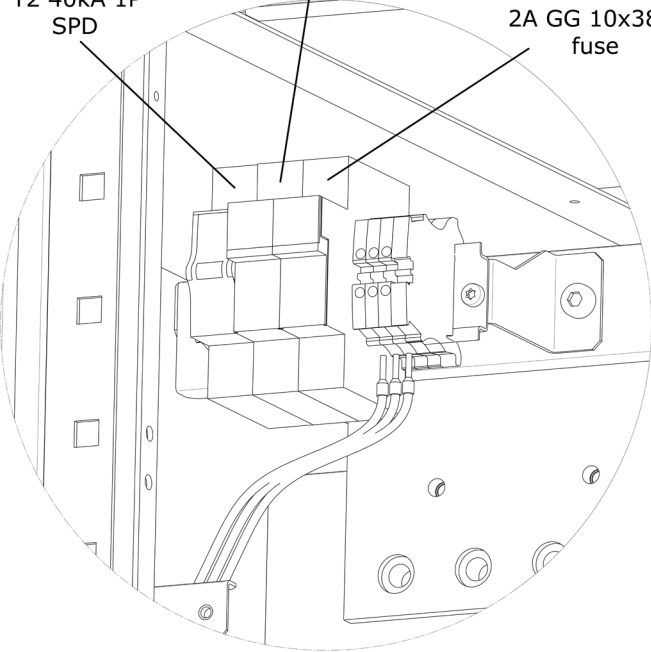

KEOR MOD 250

6.6 Extraordinary maintenance

Contact the LEGRAND Technical Support Service if there are failures that require the access to internal parts of the UPS.

7. Warehousing



DANGER

All storage operations must be carried out only by a **SKILLED TECHNICIAN** (paragraph 2.2.1)



DANGER

A SKILLED TECHNICIAN must check that there is no voltage present before disconnecting the cables. All the battery isolator switches on the UPS and on the EBC must be open.

All the battery isolator switches on the UPS and on the external battery cabinets must be open. The battery drawers of the UPS and of the external battery cabinet (if present) must be removed.

7.1 UPS

The UPS must be stored in an environment with a room temperature between -20°C (-4°F) and +50°C (+122°F) and humidity less than 90% (not condensing).

7.2 Batteries

It is possible to store batteries without recharging them in the following conditions:

- up to 6 months if the temperature is between +20°C (+68°F) and +30°C (+86°F);
- up to 3 months if the temperature is between +30°C (+86°F) and +40°C (+104°F);
- up to 2 months if the temperature is over +40°C (+104°F).



CAUTION

Batteries must never be stored if partially or totally discharged.

LEGRAND is not liable for any damage or bad functioning caused to the UPS by wrong warehousing of the batteries.

8. Dismantling



DANGER

Dismantling and disposal operations must be carried out only by a **SKILLED TECHNICIAN** (paragraph 2.2.1). The instructions in this chapter are to be considered indicative: in every country there are different regulations regarding the disposal of electronic or hazardous waste such as batteries. It is necessary to strictly adhere to the standards in force in the country where the equipment is used.

Do not throw any component of the equipment in the ordinary rubbish.

8.1 Battery disposal

Batteries must be disposed of in a site intended for the recovery of toxic waste. Disposal in the traditional rubbish is not allowed. Apply to the competent agencies in your countries for the proper procedure.



WARNING

A battery may constitute a risk of electric shock and high short-circuit current. When working on batteries, the prescriptions indicated in chapter 2 must be adhered to.

8.2 UPS dismantling

The dismantling of the UPS must occur after the dismantling of the various parts it consists of.

For the dismantling operations, it is necessary to wear the Personal Protective Equipment mentioned in paragraph 2.3. Sub-divide the components separating the metal from the plastic, from the copper and so on according to the type of selective waste disposal in the country where the equipment is dismantled.

If the dismantled components must be stored before their disposal, be careful to keep them in a safe place protected from atmospheric agents to avoid soil and groundwater contamination.

8.3 Electronic component dismantling

For the disposal of electronic waste, it is necessary to refer to the relevant standards.



This symbol indicates that in order to prevent any negative effects on the environment and on people, this product should be disposed of separately from other household waste, by taking it to authorised collection centres, in accordance with the EU countries local waste disposal legislations. Disposing of the product without following local regulations may be punished by law. It is recommended to check that this equipment subject to WEEE legislations in the country where it is used.

To remove the display, unscrew the four nuts on four M3 threaded studs that secure the display to the cabinet.

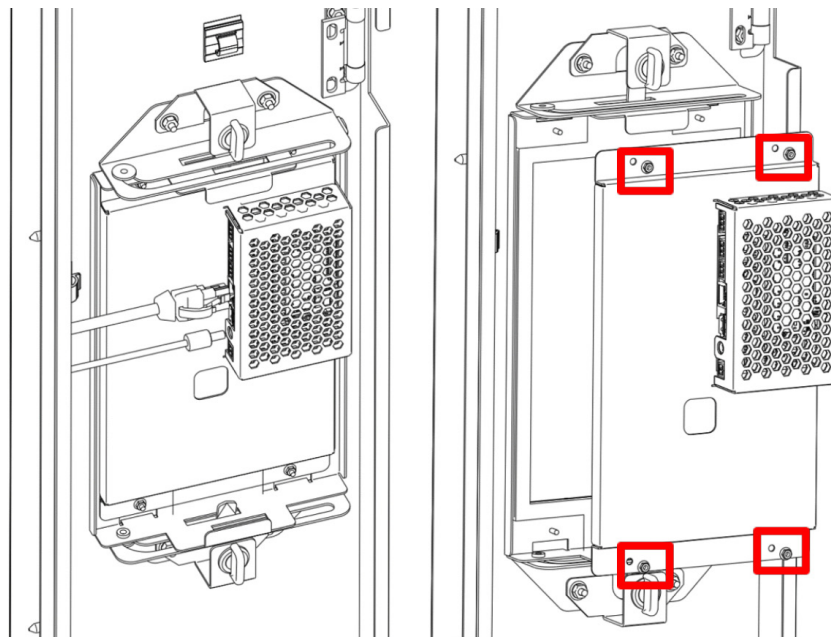

9. Mechanical characteristics

The UPSs Keor MOD are sold as empty power cabinets. It is necessary to purchase the power modules separately.

9.1 Cabinets

(all the dimensions are in mm)

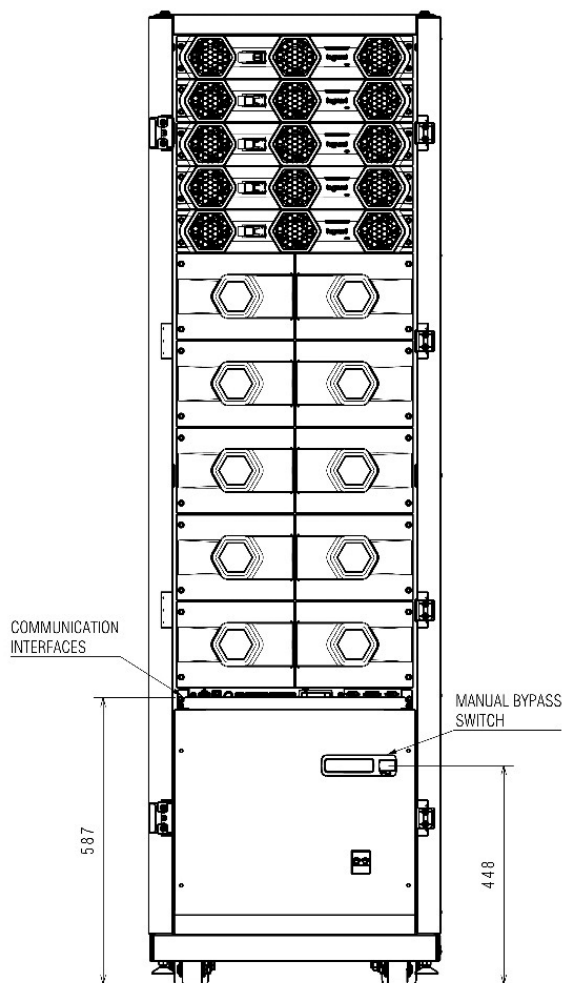

3 104 80 KEOR MOD 25-125 kVA

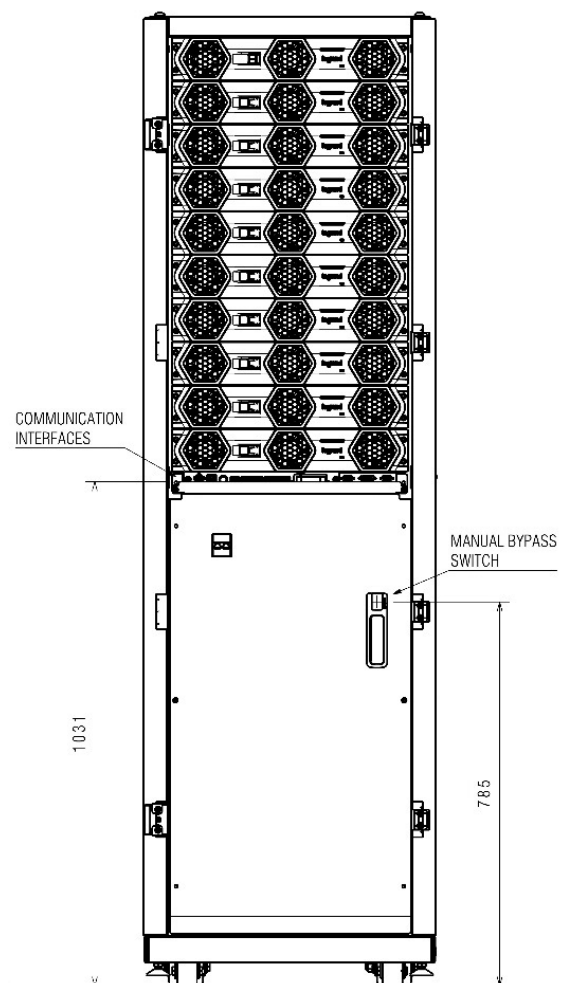

3 104 81 KEOR MOD 25-250 kVA

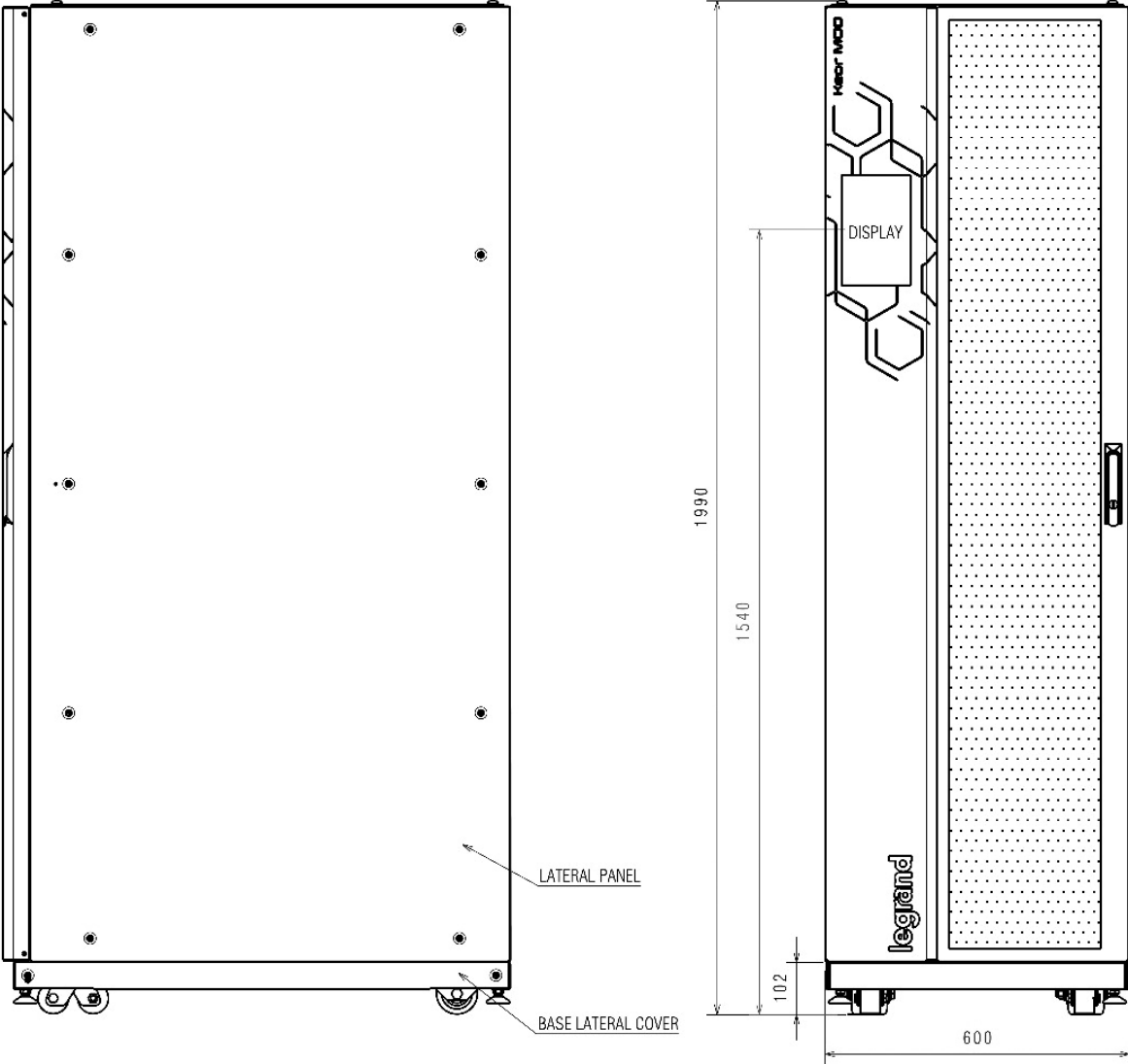

9. Mechanical characteristics

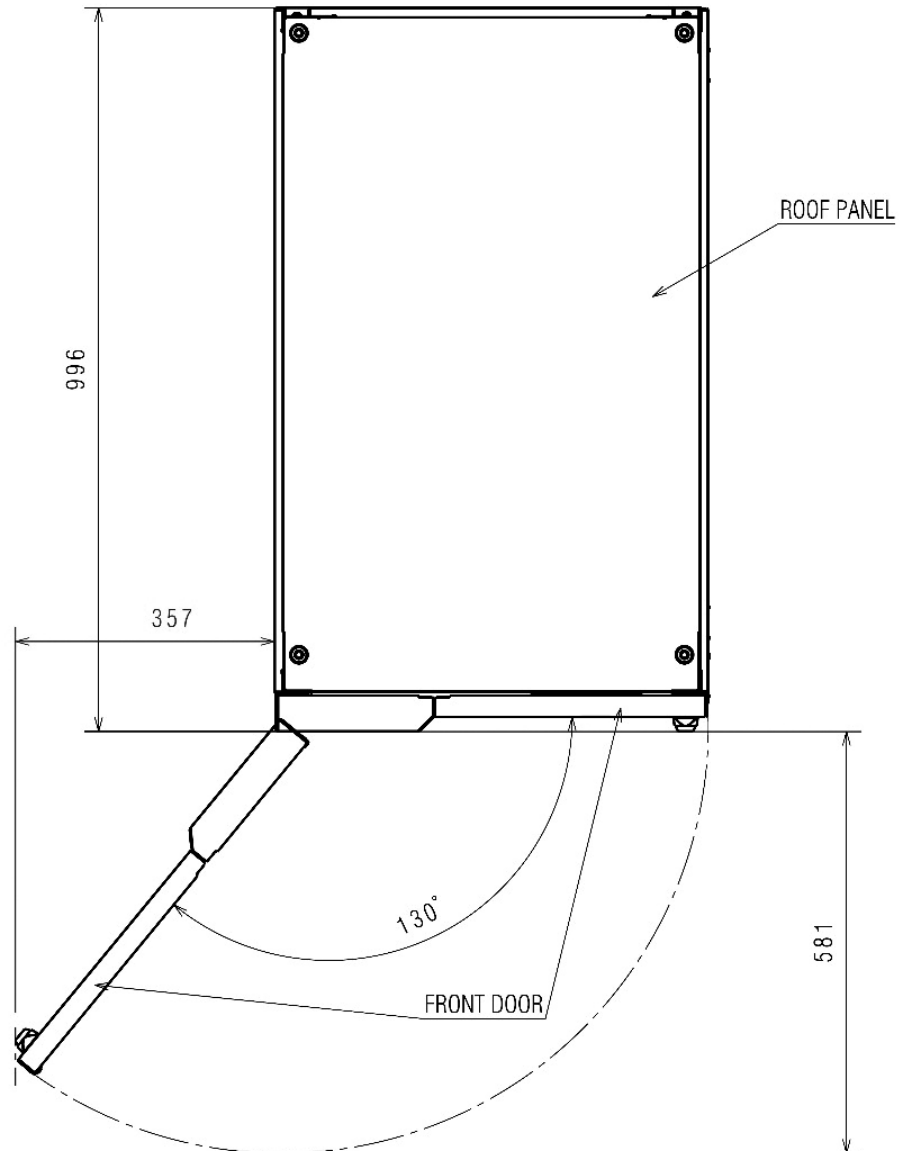

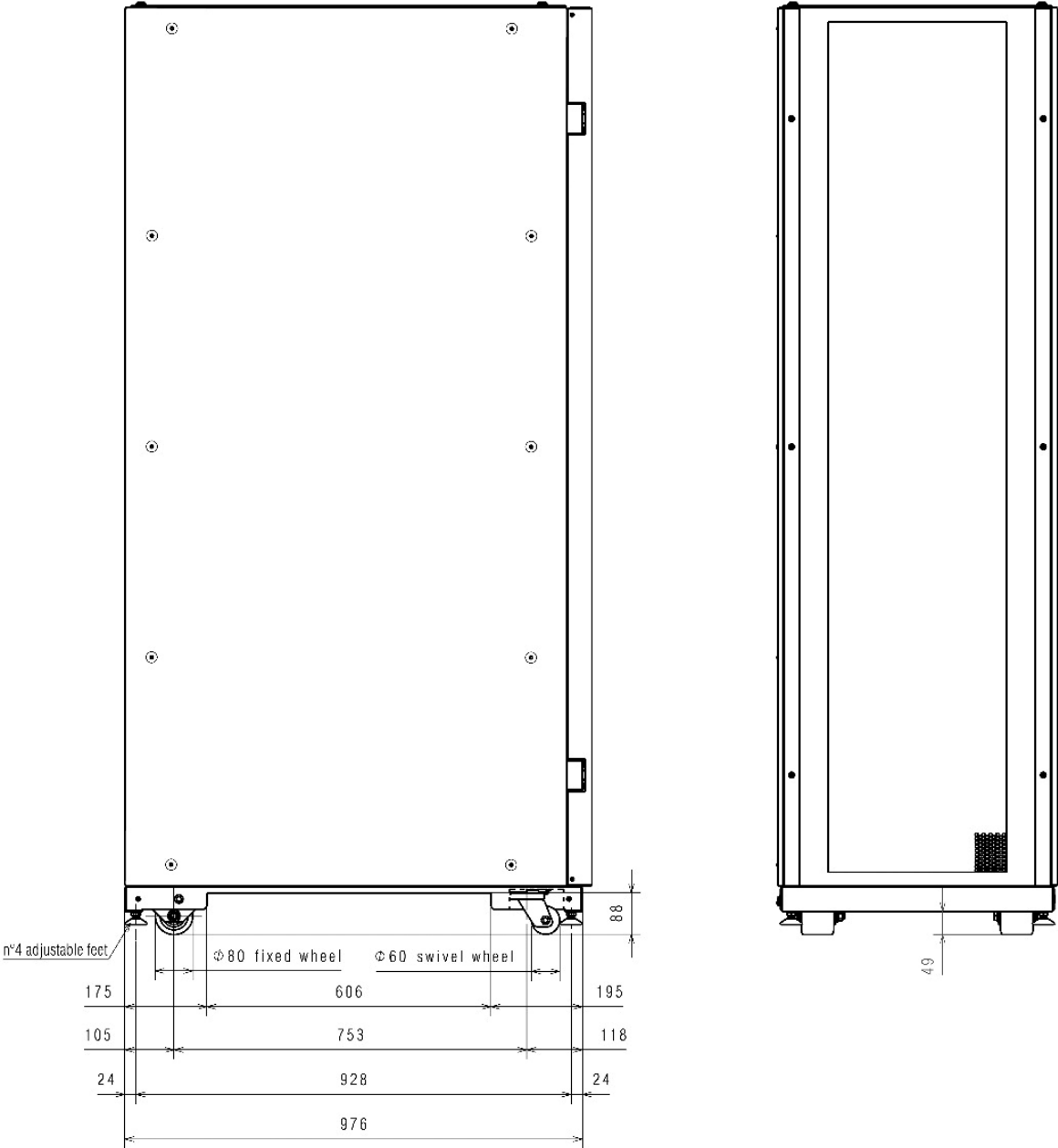

9. Mechanical characteristics

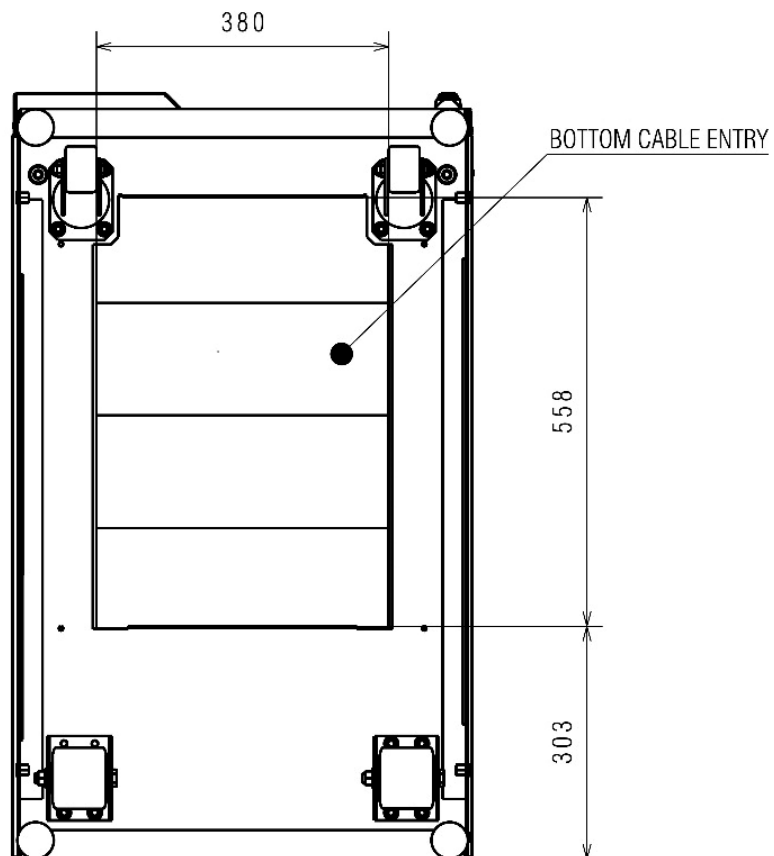

9.2 Power module PM25
(all the dimensions are in mm)

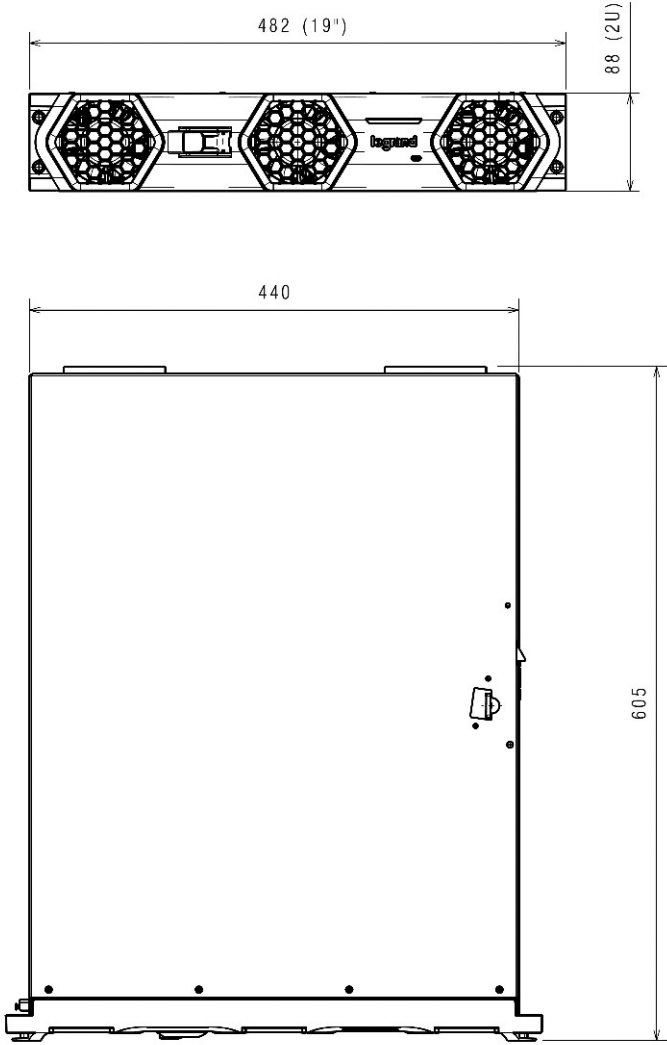

9. Mechanical characteristics

9.3 Battery drawer

(all the dimensions are in mm)

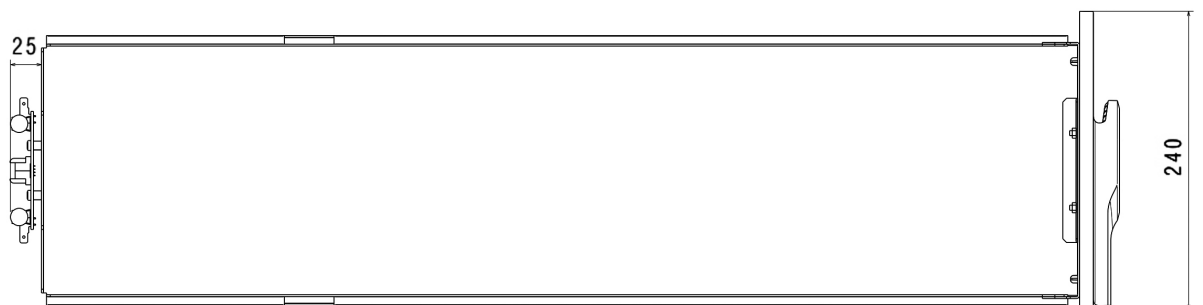
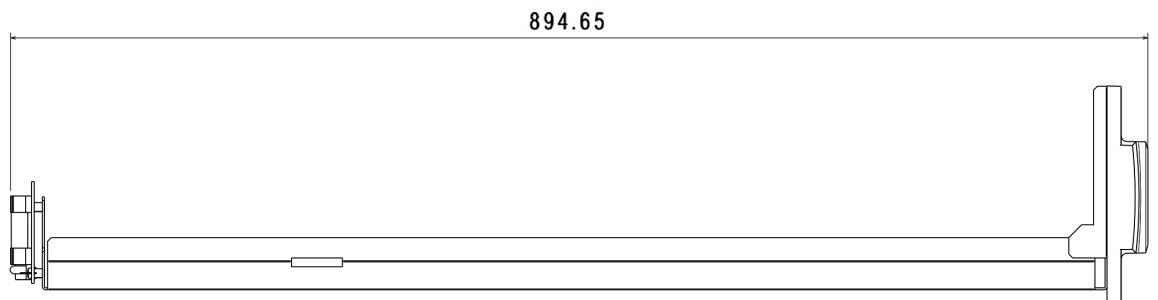
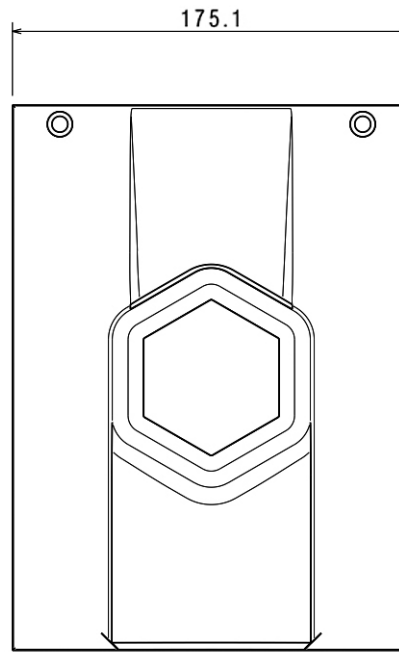

9.4 Battery block
(all the dimensions are in mm)

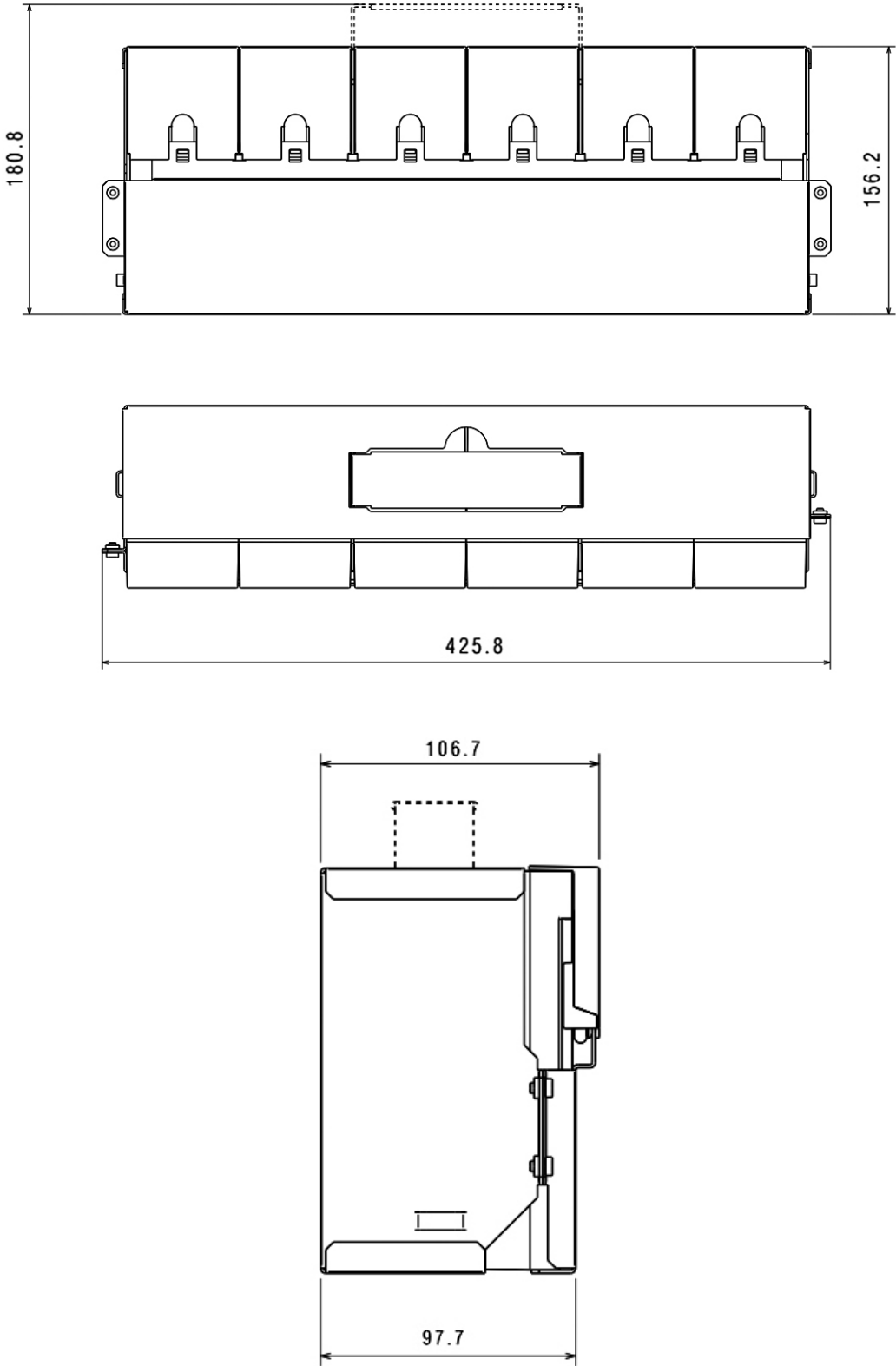

10. Technical data

Main features

	Keor MOD 25	Keor MOD 50	Keor MOD 75	Keor MOD 100	Keor MOD 125	Keor MOD 150	Keor MOD 175	Keor MOD 200	Keor MOD 225	Keor MOD 250
Nominal Power (kVA)	25	50	75	100	125	150	175	200	225	250
Active Power (kW)	25	50	75	100	125	150	175	200	225	250
Number of power modules	1	2	3	4	5	6	7	8	9	10
Technology	online, double conversion VFI-SS-111 (EN IEC 62040-3)									
IN/OUT configuration	Three-phase / Three-phase									
Dual Input	Available									
UPS system	Modular, expandable and redundant									
Neutral system	Neutral passing straight from input to output (not isolated)									
Bypass	Automatic (static) Manual (for maintenance)									
Overvoltage category	OVC II									
Protection class (EN/IEC 61140)	I									
AC power distribution system compatibility	TN, TT									

Input electrical characteristics

	Keor MOD 25	Keor MOD 50	Keor MOD 75	Keor MOD 100	Keor MOD 125	Keor MOD 150	Keor MOD 175	Keor MOD 200	Keor MOD 225	Keor MOD 250
Rated input current (A) (full load and 400V input voltage)	37.6	75	113	150	188	225.6	263.2	300	338	376
Maximum input current (A) (full load and 320V input voltage)	47	94	141	188	235	282	329	376	423	470
Input voltage (V)	400 + 15% - 20% (3P+N+PE)									
Input frequency (Hz)	50 / 60 ± 2% 50 / 60 +14% - 6% (autosensing and/or selectable by the user)									
Input Power Factor	> 0.99									
Total harmonic distortion of the input current	THDi < 4% (at full load)									
I _{cp} Prospective short-circuit current (kA)	10									

Output electrical characteristics (normal mode)

	Keor MOD 25	Keor MOD 50	Keor MOD 75	Keor MOD 100	Keor MOD 125	Keor MOD 150	Keor MOD 175	Keor MOD 200	Keor MOD 225	Keor MOD 250
Maximum output current (A)	36	72	108	144	180	216	252	288	324	360
Output voltage (V)	380/400/415 ± 1% (3P+N+PE)									
Output frequency (Hz)	50 / 60 (selectable by the user)									
Range of the output frequency	If synchronized with the bypass frequency: adjustable range from +14% to -6% If not synchronized (free run): ± 0.1 Hz									
Crest factor admitted on the output current	3:1									
Total harmonic distortion of the output voltage	THDv < 0.9% (at full linear load) for Keor MOD 125-250									
Efficiency in Normal Mode	up to 96.5%									
Efficiency in Eco Mode	up to 98.8%									
Overload capacity	125% for 10 minutes without automatic bypass intervention 150% for 60 seconds without automatic bypass intervention									

Output electrical characteristics (battery mode)

	Keor MOD 25	Keor MOD 50	Keor MOD 75	Keor MOD 100	Keor MOD 125	Keor MOD 150	Keor MOD 175	Keor MOD 200	Keor MOD 225	Keor MOD 250
Output voltage (V)	380/400/415 ± 1%									
Output frequency (Hz)	50 / 60 Hz ± 1%									
Total harmonic distortion of the output voltage	THDv < 0.7% (at full linear load) for Keor MOD 125-250									
Overload capacity	115% for 10 minutes									
Shortcircuit	I _{cc} = 3 I _n for 50 ms									

10. Technical data

Batteries and battery charger characteristics

	Keor MOD 25	Keor MOD 50	Keor MOD 75	Keor MOD 100	Keor MOD 125	Keor MOD 150	Keor MOD 175	Keor MOD 200	Keor MOD 225	Keor MOD 250
Nominal battery voltage (V)	± 288 (48 blocks)									
Battery voltage range (V)	± 264 to ± 312 (44-52 blocks)									
Battery wiring	Internal batteries: string made up of 2 drawers (composed by 4 blocks of 6 batteries) External batteries						Only external batteries			
Battery type	VRLA						-			
Unitary capacity	12 Vdc - 9 Ah 12 Vdc - 11 Ah						-			
Type of battery charger	High performance PWM, one for each power module Smart charge technology (3-stage advanced cycle)									
Maximum recharge current (A)	5 (for each power module installed)									
Independent battery configuration	maximum 5 sets of independent batteries (configurable as common or separate units)									

Features

	Keor MOD 25	Keor MOD 50	Keor MOD 75	Keor MOD 100	Keor MOD 125	Keor MOD 150	Keor MOD 175	Keor MOD 200	Keor MOD 225	Keor MOD 250
Display	10-inch rotating colour touchscreen									
Communication ports	2 x RS485 ports (one for external accessories) 10 input floating contacts 8 output floating contacts 1 interface slot USB host port									
Protections	Backfeed protections (NC/NO auxiliary contact) Emergency Power Off (EPO) Electronic against overloads, short-circuit and excessive battery discharge Block of functions due to end of autonomy In-rush limiter on start-up Internal battery circuit fuses (for internal battery drawers)									
Remote management	available									

Mechanical characteristics

	Keor MOD 25	Keor MOD 50	Keor MOD 75	Keor MOD 100	Keor MOD 125	Keor MOD 150	Keor MOD 175	Keor MOD 200	Keor MOD 225	Keor MOD 250
Empty power cabinet	3 104 80					3 104 81				
Net weight (kg)	256					233				
Dimensions H x W x D (mm)	1990 x 600 x 1000									
Installable Power modules PM25 3 106 75	up to 5					up to 10				
PM25 net weight (kg)	22.5									
Installable battery drawers	up to 10					-				
Weight of one battery block (kg)	17 (9Ah batteries) 19.2 (11Ah batteries)					-				
Weight of one battery drawer with 4 battery blocks (kg)	72 (9Ah batteries) 81 (11Ah batteries)					-				

10. Technical data

Environmental conditions

	Keor MOD 25	Keor MOD 50	Keor MOD 75	Keor MOD 100	Keor MOD 125	Keor MOD 150	Keor MOD 175	Keor MOD 200	Keor MOD 225	Keor MOD 250
Operating temperature (°C)	0 ÷ +40									
Relative humidity during operation	0% ÷ 95% non-condensing									
Storage temperature (°C)	-25 - +55 (excluding batteries)									
Noise level at 1 metre (dBA)	up to 79									
Ingress Protection Code	IP 20									
Pollution degree	PD2									
Climatic class (EN IEC 60721-3-3)	3K22									
Special climatic class (EN IEC 60721-3-3)	3Z2									
Biological class (EN IEC 60721-3-3)	3B2									
Mechanical class (EN IEC 60721-3-3)	3M11									
Mechanically active substances class (EN IEC 60721-3-3)	3S5									
Operating height	up to 1000 metres above sea level without derating									
Heat dissipation with full load (BTU/h)	3560	7120	10680	14240	17800	21360	24920	28480	32040	35600

Reference directives and standards

Marks	CE, EAC, CMIM, UKCA
Safety	Directive 2014/35/EU EN IEC 62040-1
EMC	Directive 2014/30/EU EN IEC 62040-2
Performance and test requirements	EN IEC 62040-3

11. Tables



CAUTION

The choice of the type and section of the power cables must be done according to the voltage and rated current as well as the local wiring standards and regulations. It is a responsibility of the installation engineer.

The input current and the output power of the UPS are indicated in chapter 10 and the battery current in table 5 of this chapter.

The following tables give an indication of the wire cross sections to use if the wires are unipolar with simple PVC installation and installation in tube in the air.

TABLE 1
Minimum wire cross sections recommended

POWER	INPUT CABLE	BYPASS CABLE (in case of separate bypass line)	OUTPUT CABLE
125 kVA	Phase: 1 x 95 mm ² or 2 x 50 mm ² per pole Neutral: 1 x 120 mm ² or 2 x 70 mm ²	Phase: 1 x 95 mm ² or 2 x 50 mm ² per pole Neutral: 1 x 120 mm ² or 2 x 70 mm ²	Phase: 1 x 95 mm ² or 2 x 50 mm ² per pole Neutral: 1 x 120 mm ² or 2 x 70 mm ²
250 kVA	Phase: 1 x 185 mm ² or 2 x 95 mm ² per pole Neutral: 1 x 240 mm ² or 2 x 120 mm ²	Phase: 1 x 185 mm ² or 2 x 95 mm ² per pole Neutral: 1 x 240 mm ² or 2 x 120 mm ²	Phase: 1 x 150 mm ² or 2 x 70 mm ² per pole Neutral: 1 x 240 mm ² or 2 x 120 mm ²

11. Tables

TABLE 2
Maximum wire cross sections and maximum crimping lugs

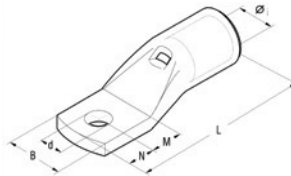

CABINET	INPUT - BYPASS - OUTPUT	NEUTRAL	BATTERY (CONFIGURED AS COMMON BATTERY)
KEOR MOD 125	<p>up to 95 mm² B = 25 mm (M8 standard palm width)</p> <p>up to 185 mm² B = 24,5 mm (M8 contained palm width)</p>	<p>up to 120 mm² B = 28,5 mm (M8 standard palm width)</p> <p>up to 185 mm² B = 24,5 mm (M8 contained palm width)</p> <p>for independent strings of battery up to 16 mm² B = 11,5 mm (M5 contained palm width)</p>	<p>1 x up to 120 mm² B = 28,5 mm (M8 standard palm width)</p> <p>1 x up to 185 mm² B = 24,5 mm (M8 contained palm width)</p> <p>2 x up to 70 mm² B = 21 mm (M8 standard palm width)</p> <p>2 x up to 150 mm² B = 19 mm (M8 contained palm width)</p>
KEOR MOD 250	<p>up to 150 mm² B = 31,5 mm (M10 standard palm width)</p> <p>up to 240 mm² B = 31 mm (M10 contained palm width)</p>	<p>3 x up to 240 mm² B = 31,5 mm (M10 standard palm width)</p> <p>3 x up to 300 mm² B = 31 mm (M10 contained palm width)</p> <p>6 x up to 120 mm² B = 28,5 mm (M10 standard palm width)</p> <p>6 x up to 185 mm² B = 24,5 mm (M10 contained palm width)</p>	<p>1 x up to 240 mm² B = 39 mm (M8 standard palm width)</p> <p>2 x up to 120 mm² B = 28,5 mm (M8 standard palm width)</p> <p>2 x up to 150 mm² B = 19 mm (M8 contained palm width)</p>

TABLE 3
Automatic breaker recommended for input and bypass line

POWER	AUTOMATIC CIRCUIT BREAKER
125 kVA	In=250 A curve C Icp=10kA
250 kVA	In=630 A curve C Icp=10kA

TABLE 4
Residual current breaker recommended for input and bypass line

POWER	RESIDUAL CURRENT BREAKER (I Δ n)
125 kVA	≥ 300 mA type B
250 kVA	

TABLE 5
Maximum current absorbed by the batteries at full load and recommended wire cross sections for connecting the UPS to the external battery cabinets

POWER	MAXIMUM BATTERY CURRENT	RECOMMENDED WIRE CROSS SECTION	RECOMMENDED FUSES
125 kVA	300 A	Common battery: 1 x 150 mm ² (per pole) Independent strings: 5 x 16 mm ² (per pole)	DC ultra rapid type aR or gR 315 A (1 per pole) *
250 kVA	600 A	Common battery: 2 x 150 mm ² (per pole) Independent strings: 5 x 35 mm ² (per pole)	DC ultra rapid type aR or gR 315 A (2 per pole) *

* NOTE: Contact the Legrand Technical Support Service to know the correct fuses to be installed. UPS produced in the past may need to use only aR fuses with I²t= 39600 for the 125 kVA model or with I²t= 158400 for the 250 kVA model.

INDICATION

The maximum length of the battery cables is 25 m.

TABLE 6
External battery cabinets

ITEM CODE	CABINET DIMENSION (L X D X H) mm	SWITCHES AND PROTECTION KIT	BATTERIES (Ah)
3 109 65	1200 x 900 x 1900	1x FUSE HOLDER 3P NH2 400A - 3x aR FUSE 315A	70-93
3 109 67	1200 x 900 x 1900	1x FUSE HOLDER 3P NH2 400A - 3x aR FUSE 350A	105
3 109 44	1200 x 900 x 1900	1x FUSE HOLDER 3P NH1 250A - 3x aR FUSE 250A	55
3 109 89	2 cabinets 810 x 840 x 1900	2 cabinets 2x FUSE HOLDER 3P NH2 400A - 3x gR FUSE 315A	80

LEGRAND
Pro and Consumer Service
BP 30076 - 87002
LIMOGES CEDEX FRANCE
www.legrand.com

┌ Installer stamp ───────────┐

└───────────────────────────┘