

DALI



	230 V~ +/- 10%	
	50 Hz	
	2.5 mm <sup>2</sup>	
	-10°C / +30 °C	
	Microwave	
	1000 lux	
	20 min.	
	Auto ON / OFF	
	min. ●●●●●● 6 x 23 m	max. (●●●●) 6 x 17 m

• Compatibilité des fréquences micro-ondes
• Microwave frequency compatibility
• Compatibilità delle frequenze microonde

0 489 55	UK, China, India, Middle East, Malaysia, Hong Kong, Singapore	10.587 GHz
0 489 56	Australia and all of Europe except: UK, France, Portugal, Germany, Switzerland, Austria, Slovak Republic, Republic of Ireland	10.525 GHz
0 489 57	France, Portugal, Switzerland	9.900 GHz

DIM+/DIM-

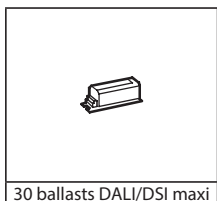

L/OUT

230 V~	 10 A	 10 A	 10 A	 10 A	 10 A
230 V~	 10 A	 10 A	 10 A	 10 A	 10 A

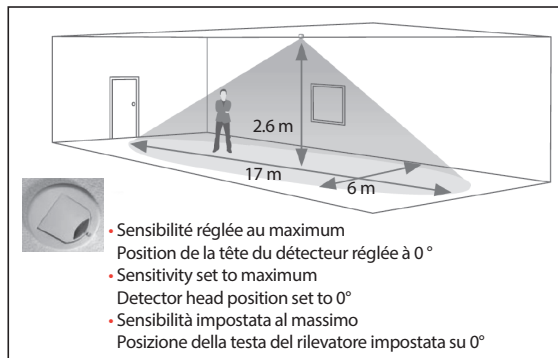
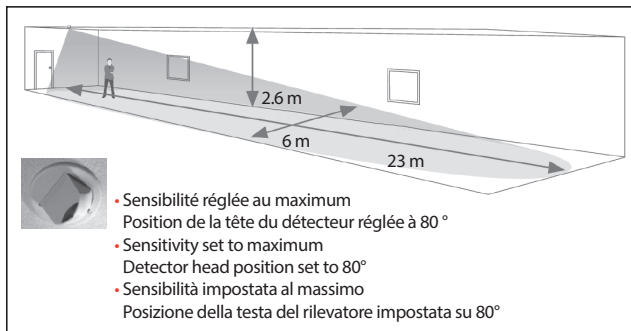

- 1**
- Retirer le clip de verrouillage métallique de l'arrière de l'unité
  - Remove metal locking clip from rear of unit
  - Rimuovere la clip di bloccaggio metallico dalla parte posteriore dell'unità

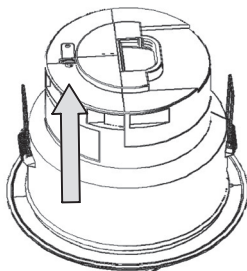

- 2**
- Ajuster la tête à la position requise. Poussez le clip dans la position illustrée ci-dessous pour verrouiller la tête. Pour retirer le clip, dégagez avec un petit tournevis.
  - Adjust head to required position. Push clip into position shown below to lock head. To remove clip, lever out with a small screwdriver.
  - Regola la testa nella posizione desiderata. Spingere la clip nella posizione mostrata sotto per bloccare la testa. Per rimuovere la clip, usare un piccolo cacciavite.

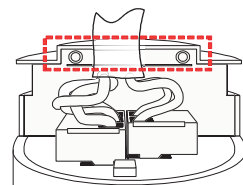
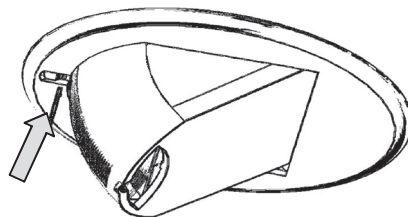



- Un seul canal de variation
- Single channel dimming
- Singolo canale di variazione

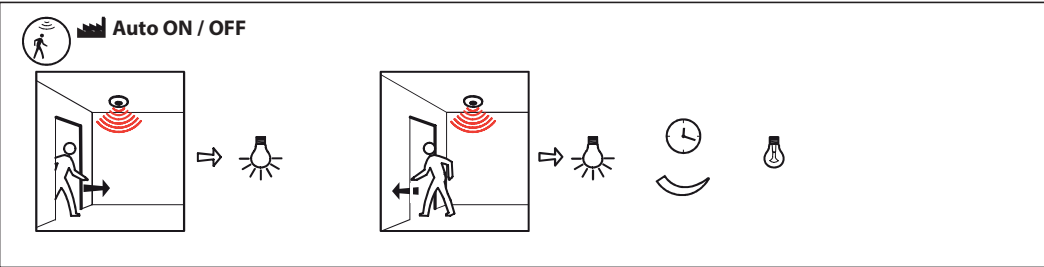
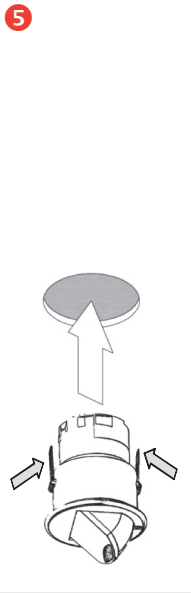
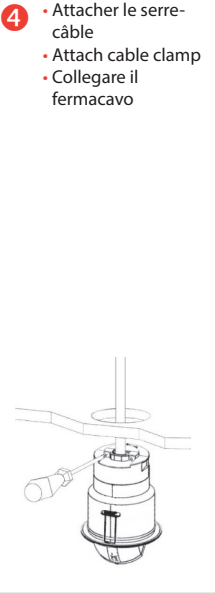
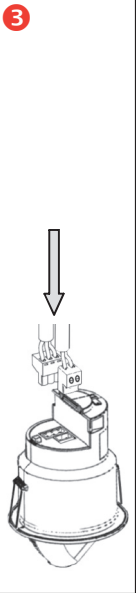
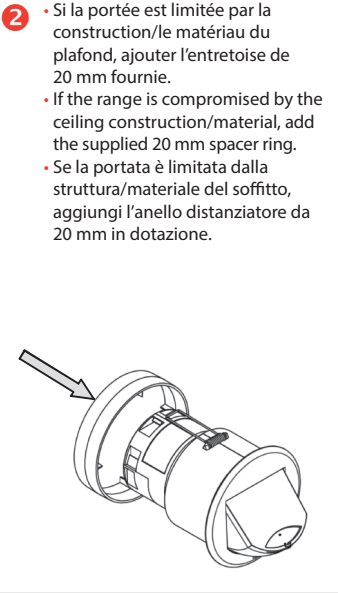
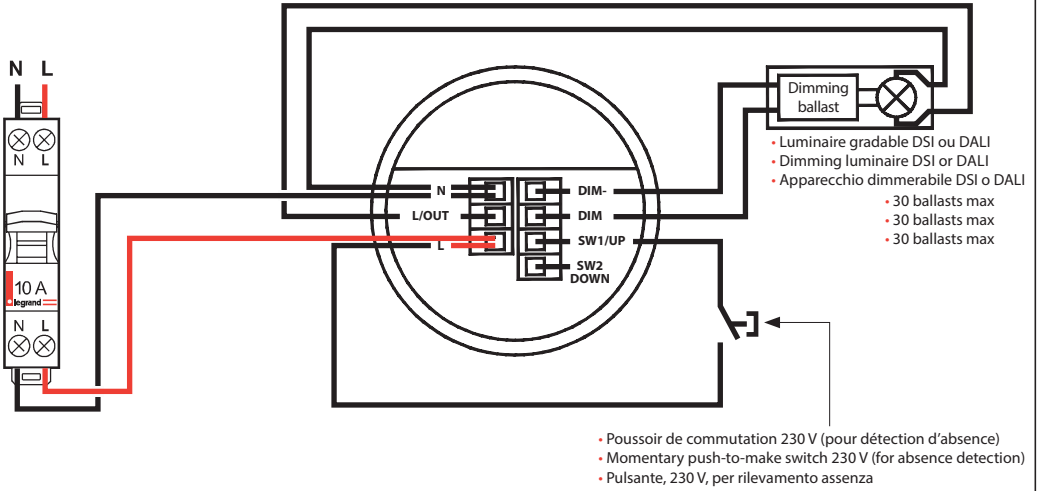



## Manual ON / Auto OFF

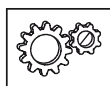
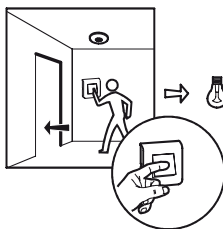
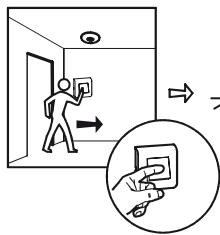

- À la première utilisation: Télécharger l'application Legrand Close Up sur l' Apple Store ou le Play Store.
- On first use: Download the Legrand Close Up app from Apple Store or Play Store
- Al primo utilizzo: Scaricare l'app Legrand Close Up su Apple Store o Play Store.

- Réf. 0 882 40 : Passerelle de configuration
- Cat. No(s) 0 882 40 : Configuration tool
- Ref. 0 882 40: Gateway di configurazione



&



Application: «Legrand Close Up»



App Store



Google Play



- Pour plus de renseignement sur les paramètres, reportez vous à la fiche technique de la passerelle de configuration Réf. 0 882 40.
- For more information about setting parameters, refer to the data sheet for the configuration gateway Cat. No. 0 882 40.
- Per maggiori informazioni sulle impostazioni, consultare la scheda tecnica del gateway di configurazione Ref. 0 882 40.

	0-1000 lux
	0-99 min.
	1-9
Mode	Auto - Manual

- Facette de montage
- Mounting bezel
- Lunetta di montaggio

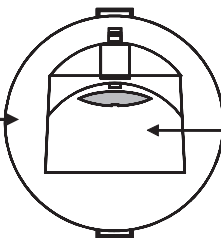

- Détecteur hyper-fréquence / récepteur IR / capteur de luminosité / LED d'état
- Microwave sensor / IR receiver / light level sensor / status LED
- Rivelatore iperfrequenza / ricevitore IR / sensore luminosità / LED di stato

- Pour la configuration, il est nécessaire d'effectuer une opération d'initialisation proposée dans l'application de configuration Legrand Close Up :

- 1 – cliquer sur "lecture des paramètres produits"
  - 2 – cliquer sur "détails de paramètres / copier"
  - 3 – dans le menu en haut à droite (...) sélectionner "Initialiser"
  - 4 – cliquer sur "écriture des paramètres produits"
- Cette opération permet le réglage prédéfini de certains paramètres.

- For configuration, it is necessary to operate an operation for initialization proposed in the Legrand Close Up application:

- 1 – click on "new scan"
  - 2 – click on "see details"
  - 3 – from the menu at the top right (...) select the action "Initialise"
  - 4 – click on "upload configuration"
- This operation allows the predefined setting of some parameters.

- Per la configurazione, è necessario eseguire un'operazione di inializzazione proposta nell'applicazione Legrand Close Up:

- 1 – clicca su "leggi i parametri del prodotto"
- 2 – clicca su "dettagli parametro"
- 3 – dal menu in alto a destra (...) selezionare "Inizializza"
- 4 – clicca su "scrivi parametri prodotto"

Questa operazione consente l'impostazione predefinita di alcuni parametri.