

	● 0 321 11	SC duplex HD 12 singlemode fibres
	● 0 321 21	SC duplex HD 12 multimode fibres
	● 0 321 10	SC duplex 6 singlemode fibres
	● 0 321 12	SC apc duplex 6 singlemode fibres
	● 0 321 20	SC duplex 6 multimode fibres
	● 0 321 13	LC duplex 6 singlemode fibres
	● 0 321 23	LC duplex 6 multimode fibres
	● 0 321 36	LC duplex 6 multimode fibres (aqua)
	● 0 321 14	LC duplex 12 singlemode fibres
	● 0 321 16	LC apc duplex 12 singlemode fibres
	● 0 321 24	LC duplex 12 multimode fibres
	● 0 321 37	LC duplex 12 multimode fibres (aqua)
	● 0 322 58	LC duplex 12 multimode fibres (lime)
	● HVBL12	LC duplex 12 multimode fibres (violet)
	● 0 321 15	LC duplex HD 24 singlemode fibres
	● 0 321 25	LC duplex HD 24 multimode fibres
	● 0 322 59	LC duplex HD 24 multimode fibres (lime)
	● HVBL24	LC duplex HD 24 multimode fibres (violet)
	● 0 321 17	ST for 6 singlemode fibres
	● 0 321 27	ST for 6 multimode fibres
	● 0 321 33	4 MTP adapter, pass-through, singlemode
	● 0 321 34	4 MTP adapter, pass-through, multimode
	● 0 321 18	8 MTP adapter, pass-through, multimode
	● 0 321 19	8 MTP adapter, pass-through, singlemode
	● AS24MM	3 Acclaim, MDC 24 fibres, multimode (aqua)
	● AS24SM	3 Acclaim, MDC 24 fibres, singlemode

<ul style="list-style-type: none"> • Accessoires • Accessoires • Accessories 	<ul style="list-style-type: none"> • Zubehör • Accesorios • Acessórios 	<ul style="list-style-type: none"> • Αξεσουάρ • Аксессуары • Accessori 	<ul style="list-style-type: none"> • 附件 • الملحقات
0 321 28	0 321 29	0 321 30	0 321 31
0 321 32	0 321 32	0 321 32	0 321 32

- Préparation
- Voorbereiding
- Preparación
- Preparazione

- Vorbereitung
- Preparación
- Preparação

- Προετοιμασία
- Подготовка
- Preparazione

- 准备工作
- التحضير

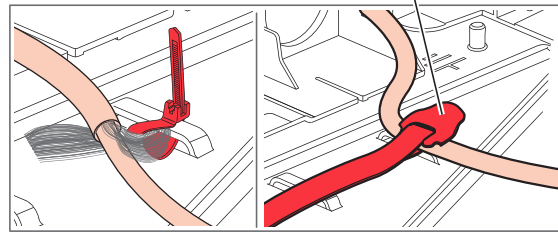
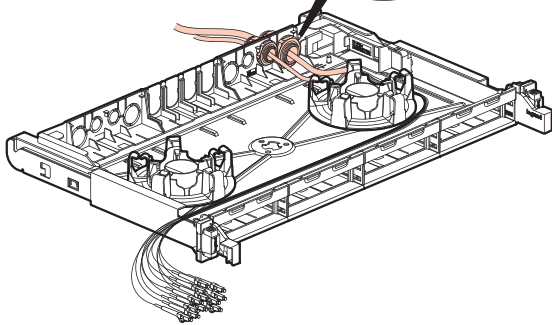
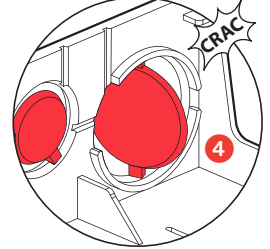
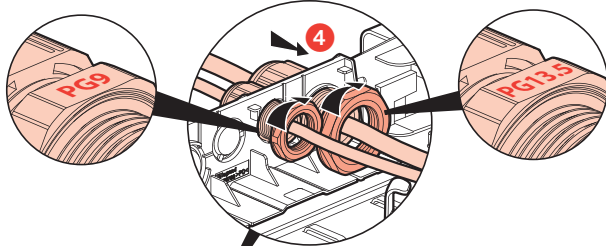
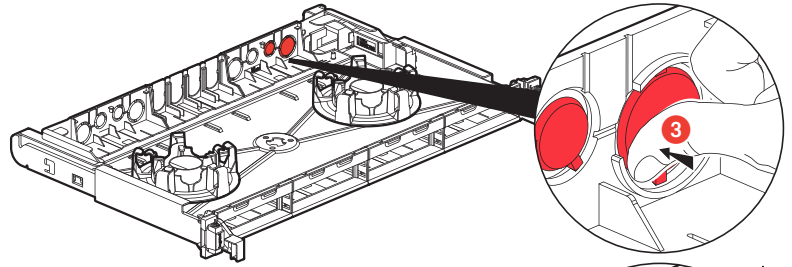
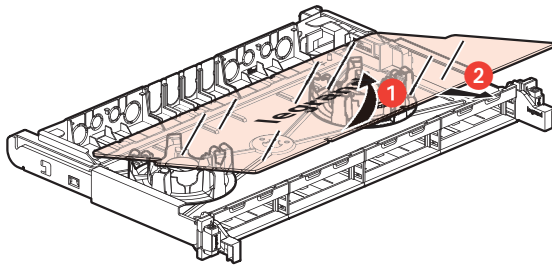

- Préconnectorisation
- Voor-connectorisatie
- Preconnectorisation

- Vorverbindung
- Preconexión
- Pré-conectorização

- Προεγκατάσταση συνδετήρων
- Монтаж кабельных разъемов
- Pre-connettorizzazione

- 预连接
- توصيل مسبق

0 331 28

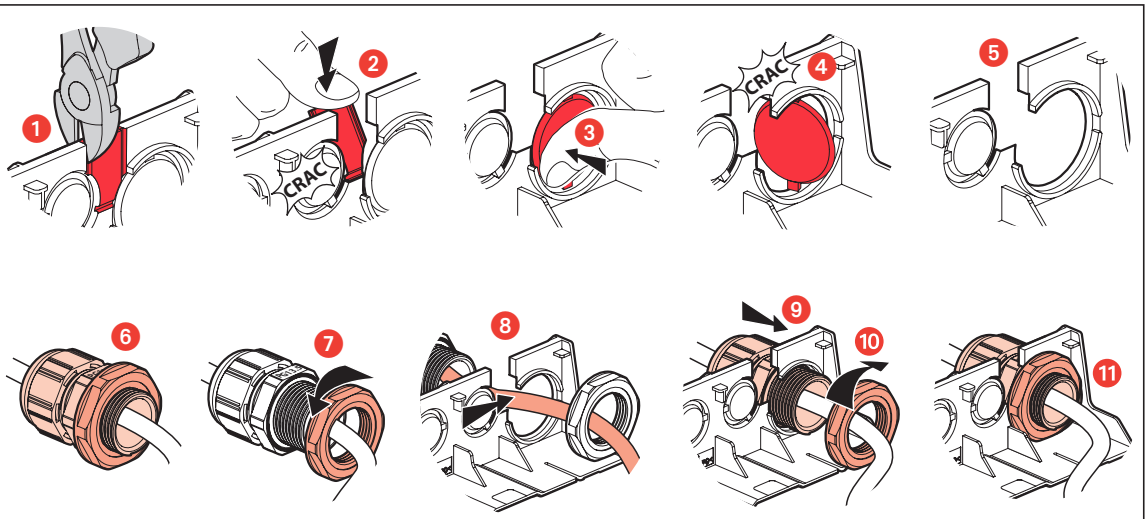
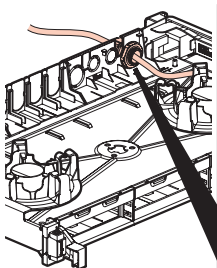
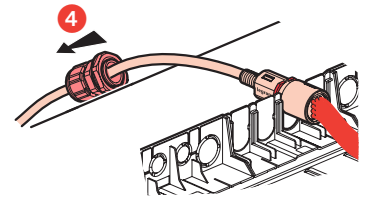
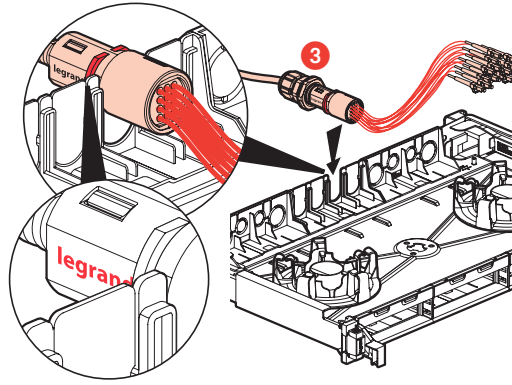
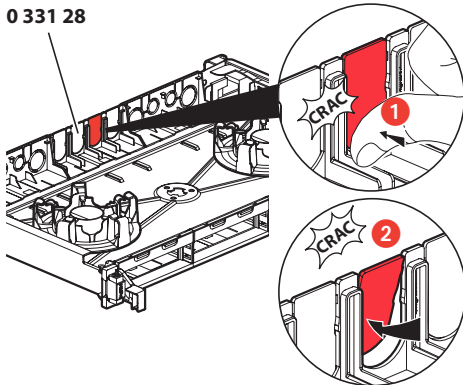



- Lovage et raccordement
- Haspels en aansluiting
- Coiling and connection

- Aufwickeln und Anschließen
- Enrollado y conexión
- Bobinagem e ligação

- Τύλιξη και σύνδεση
- Укладка и подсоединение
- Anvolgimento e collegamento

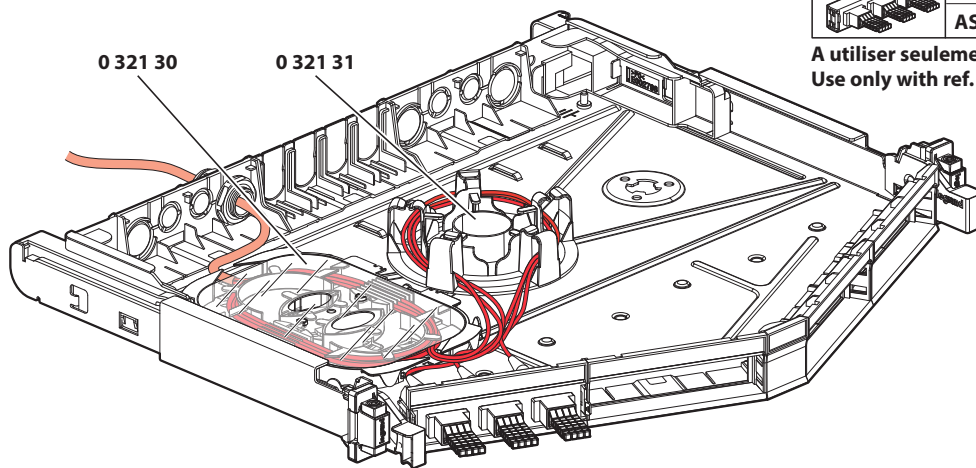
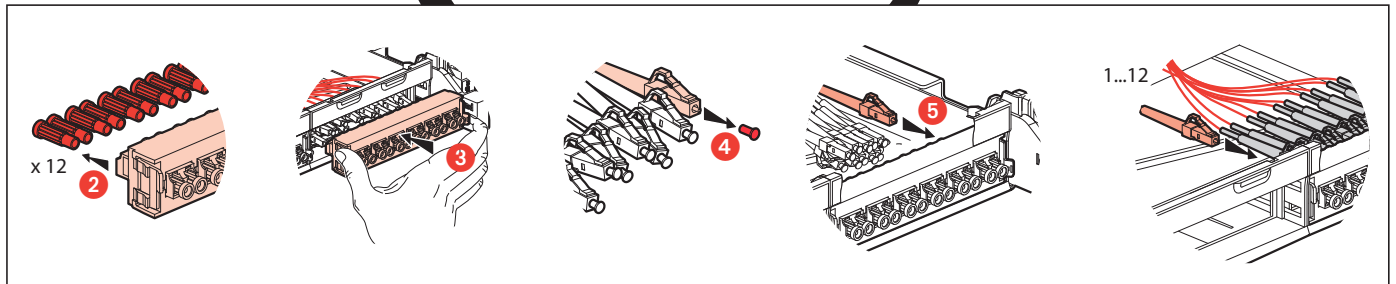
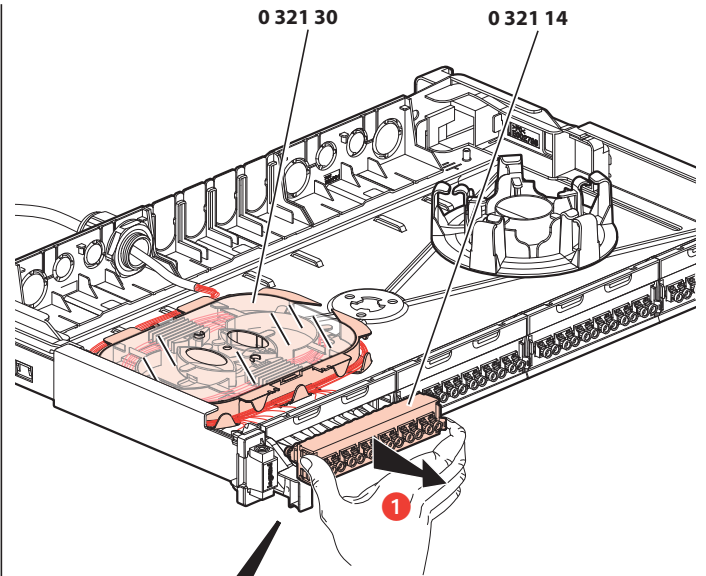
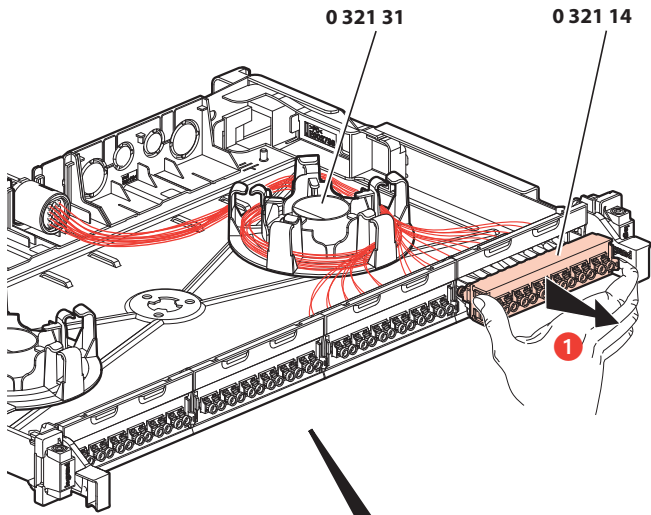
- 螺旋理线环与接头
- إنشاء الحلقات الاحتياطية والتوصيل

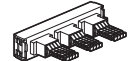

	AS24MM	3 Acclaim, MDC 24 fibres, multimode (aqua)
	AS24SM	3 Acclaim, MDC 24 fibres, singlemode

A utiliser seulement avec la réf. 0 321 01
Use only with ref. 0 321 01

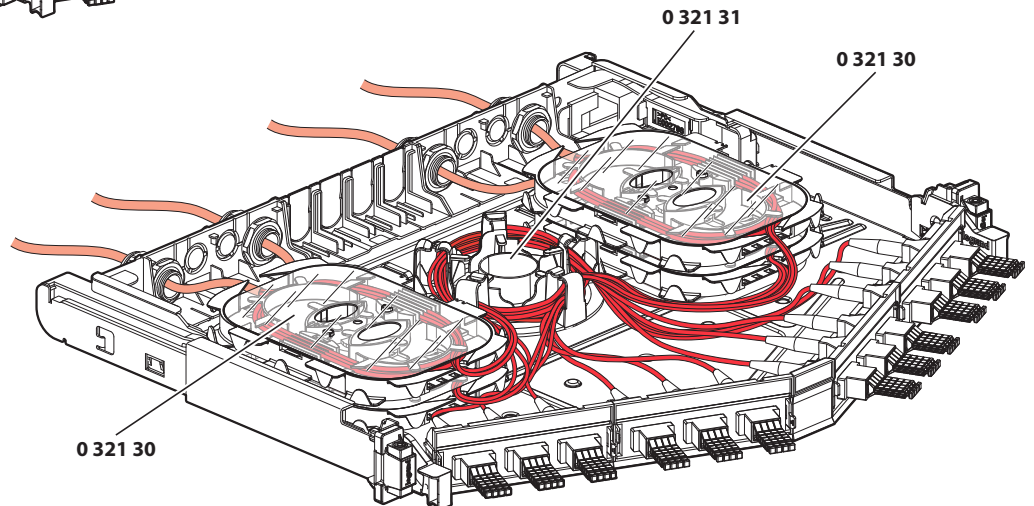

- Remontage capot
- Kap opnieuw plaatsen
- Refitting of cover

- Wiedereinbau der Abdeckung
- Colocación de la tapa
- Remontagem do capô

- Επανατοποθέτηση καλύμματος
- Установка крышки
- Rimontaggio coperchio

- 重新安裝盖板
- إعادة تركيب الغطاء

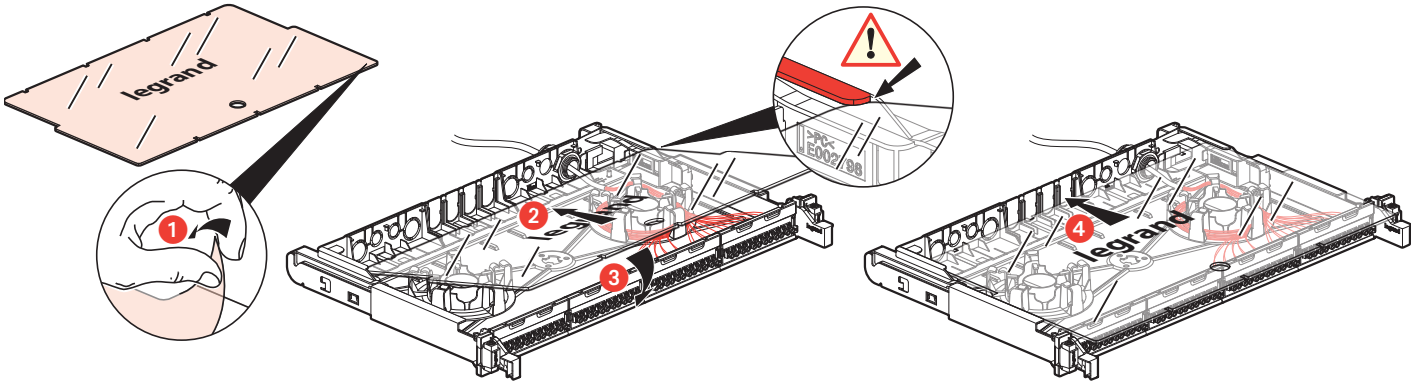

- Montage/Démontage
- Montage/demontage
- Installation/Removal

- Einbau/Ausbau
- Montaje/desmontaje
- Montagem/desmontagem

- Τοποθέτηση/Αφαίρεση
- Монтаж/демонтаж
- Montaggio/Smontaggio

- 安裝/拆卸
- التركيب/التفكيك

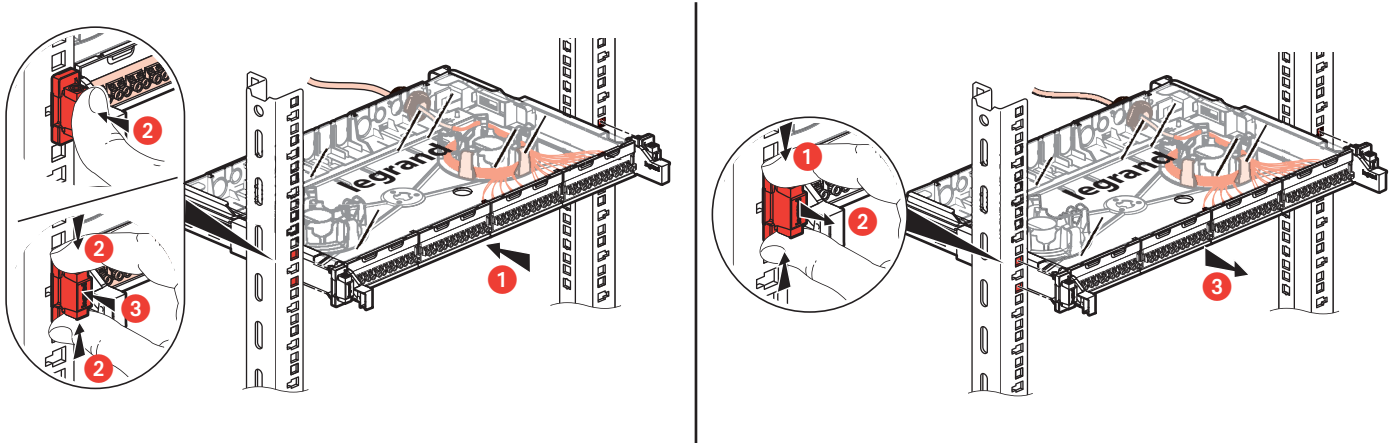

- Utilisation porte-étiquette
- Gebruik van etikethouder
- Use of label holder

- Verwendung Etikettenhalter
- Utilización del portaetiquetas
- Utilização do porta-etiquetas

- Χρήση πλαισίου τοποθέτησης ετικέτας
- Использование держателя этикетки
- Uso porta etichetta

- 使用端子标记座
- استخدام حامل الملصقات

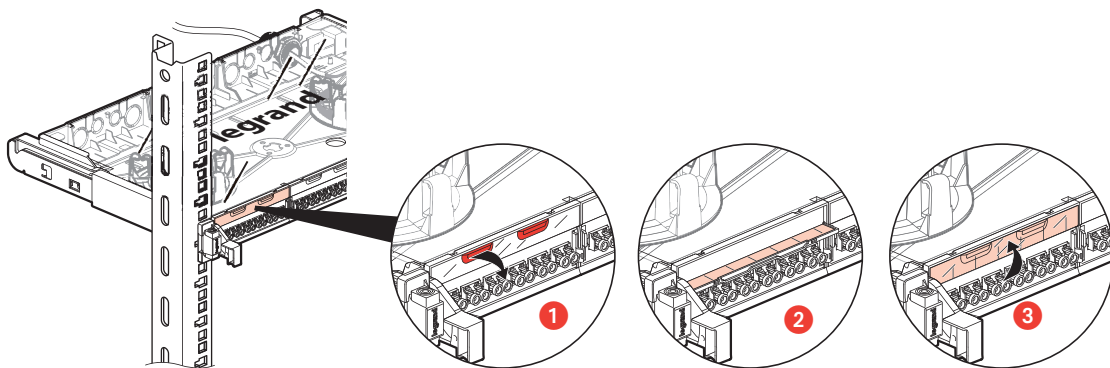

- Mise à la terre
- Aardverbinding
- Earthing

- Erdung
- Puesta a tierra
- Ligação a terra

- Γείωση
- Заземление
- Messa a terra

- 接地
- التأسيس

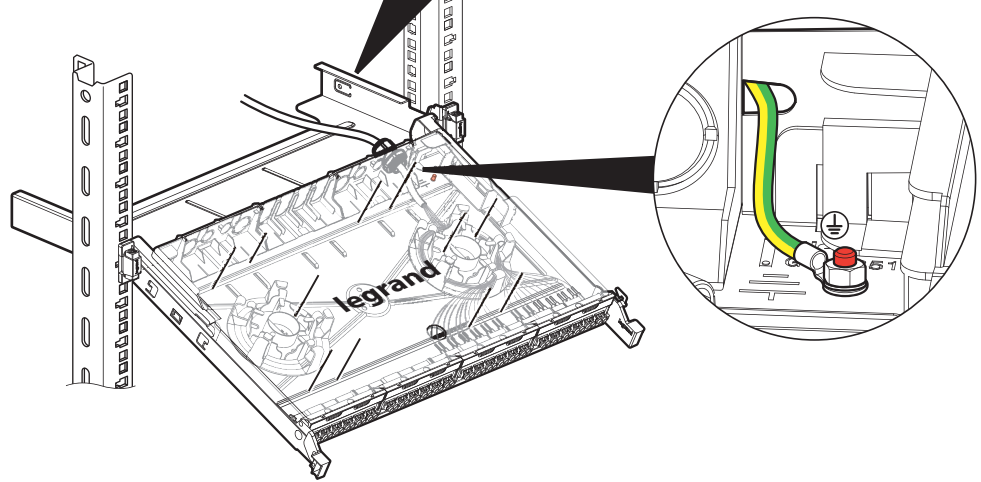
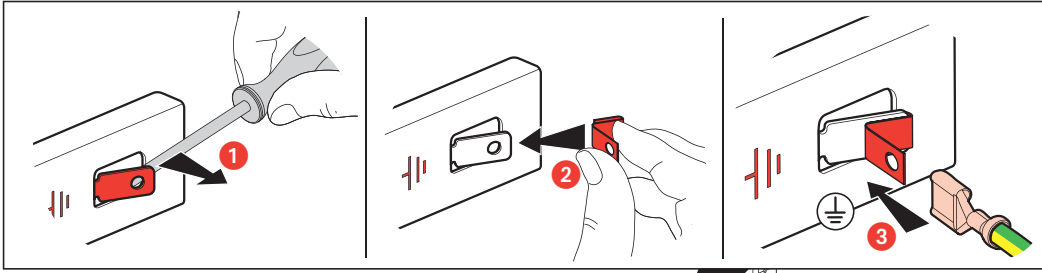

- Maintenance
- Onderhoud
- Maintenance

- Wartung
- Mantenimiento
- Manutenção

- Συντήρηση
- Техническое обслуживание
- Manutenzione

- 维护
- الصيانة

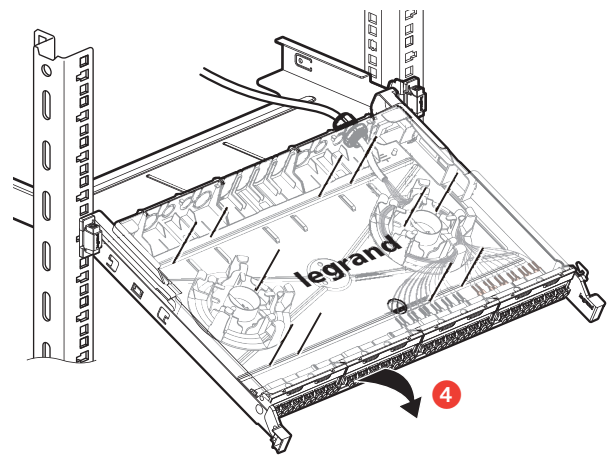
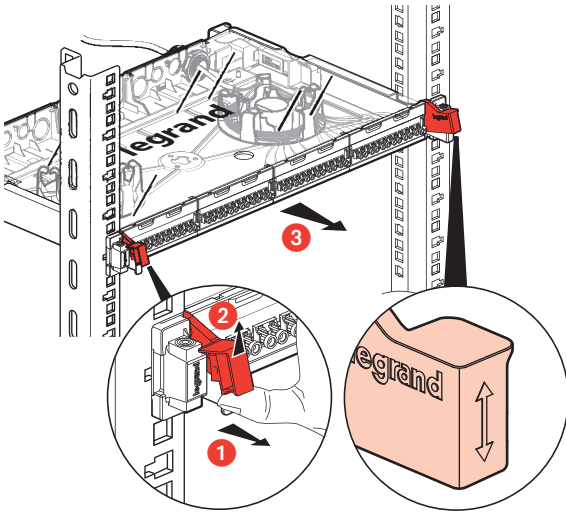

- Maintenance (suite)
- Onderhoud (vervolg)
- Maintenance (continued)

- Wartung (Fortsetzung)
- Mantenimiento (continuación)
- Manutenção (continuação)

- Συντήρηση (συνέχεια)
- Техническое обслуживание (продолжение)

- Manutenzione (segue)
- 维护 (续上页)
- الصيانة (يتبع)

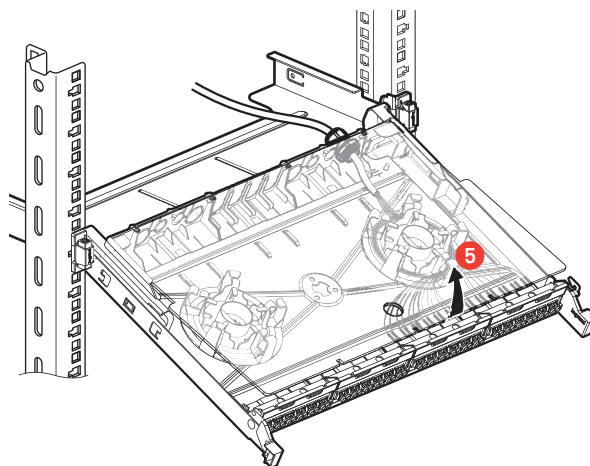

- Maintenance (remontage)
- Onderhoud (opnieuw plaatsen)
- Maintenance (reinstallation)
- Wartung (Wiedereinbau)

- Mantenimiento (remontaje)
- Manutenção (remontagem)
- Συντήρηση (επανατοποθέτηση)
- Техническое обслуживание (сборка)

- Manutenzione (rimontaggio)
- 维护 (重新安装)
- الصيانة (إعادة التركيب)

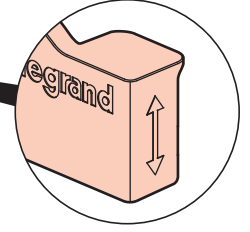
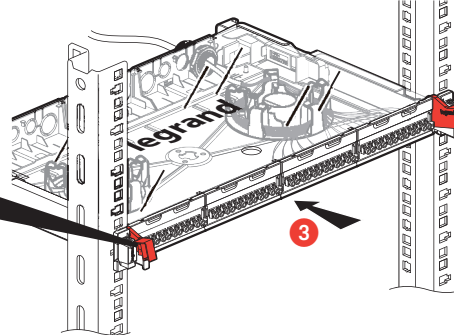
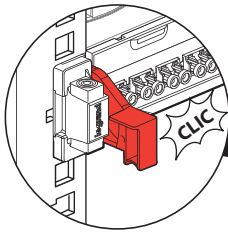
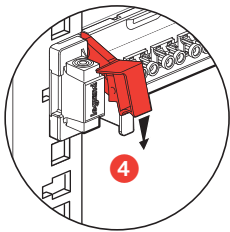
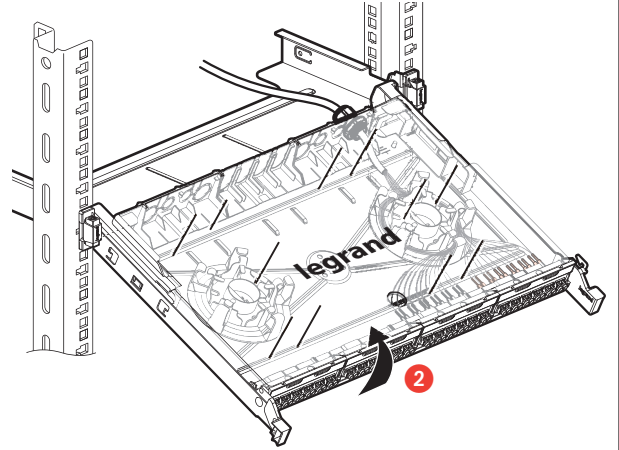
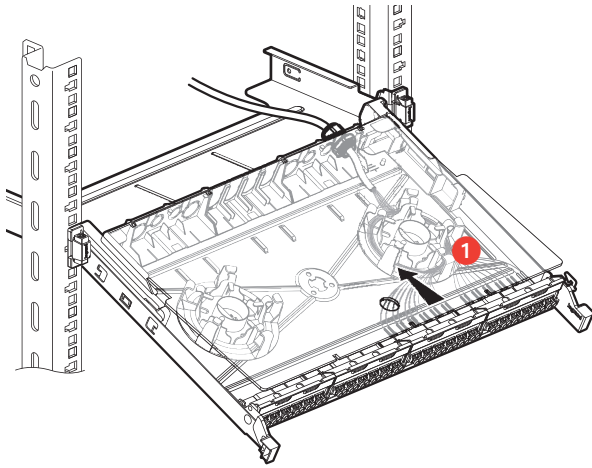

- Autres configurations
- Andere configuraties
- Other configurations

- Weitere Konfigurationen
- Otras configuraciones
- Outras configurações

- Λοιπές διαμορφώσεις
- Другие конфигурации
- Altre configurazioni

- 其他设置
- البرمجيات الأخرى

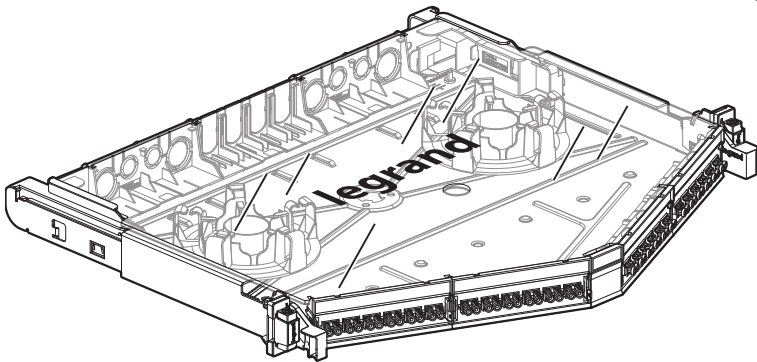
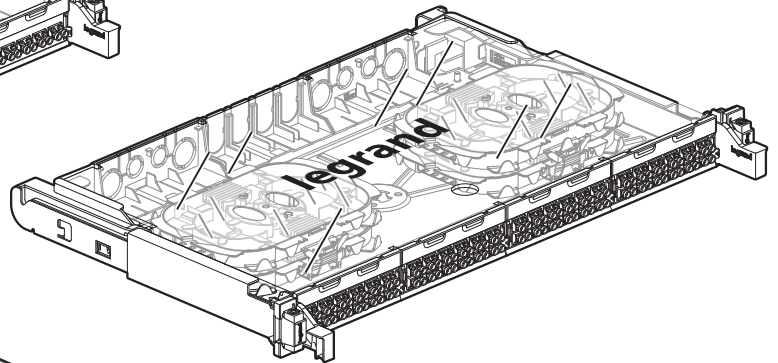
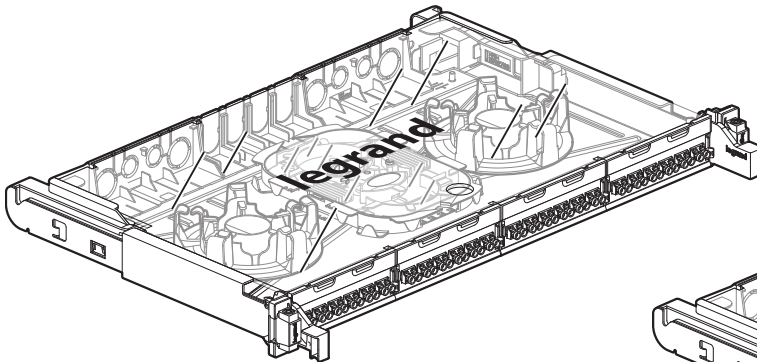

⚠ **Consignes de sécurité** (FR LU BE CH)
Avant toute intervention, couper le courant.
Respecter strictement les conditions d'installation et d'utilisation.

⚠ **Veiligheidsvoorschriften** (NL BE)
Onderbreek voor enige ingreep de stroom.
Neem de installatie- en gebruiksvoorwaarden nauwgezet in acht.

⚠ **Safety instructions** (GB IE)
Make sure the power supply is disconnected before any intervention.
Strictly comply with instructions for installation and use.

⚠ **Sicherheitshinweise** (DE CH)
Vor jeglichem Eingriff die Spannungsfreiheit sicherstellen.
Einbau- und Gebrauchsanleitungen sind genau zu beachten.

⚠ **Consignas de seguridad** (ES)
Antes de realizar cualquier intervención, cortar la corriente eléctrica.
Respetar estrictamente las condiciones de instalación y uso.

⚠ **Instruções de segurança** (PT)
Antes de qualquer intervenção, desligar a corrente.
Respeitar rigorosamente as condições de instalação e de utilização.

⚠ **Συστάσεις ασφαλείας** (GR CY)
Πριν από οποιαδήποτε επέμβαση, διακόψτε την παροχή ρεύματος.
Να τηρείτε ανστηρά τις συνθήκες εγκατάστασης και χρήσης.

⚠ **Меры предосторожности** (RU)
Отключить питание перед проведением любых ремонтных работ.
Строго соблюдайте требования к условиям монтажа и эксплуатации.

⚠ **Istruzioni di sicurezza** (IT CH)
Prima di qualsiasi intervento, interrompere l'alimentazione.
Rispettare scrupolosamente le condizioni d'installazione e uso.

⚠ **安全提示**
在任何干涉以前一定要断电，严格遵守安全和使用的规定。

⚠ **إرشادات الأمان:**
«اقطع التيار الكهربائي قبل أي تدخل. تقيّد تقيداً تاماً بشروط التركيب والاستخدام.»