

6

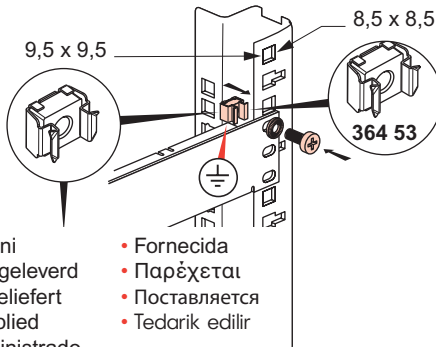

- Fourni
- Meegeleverd
- Mitgeliefert
- Supplied
- Suministrado

- Fornecida
- Παρέχεται
- Поставляется
- Tedarik edilir

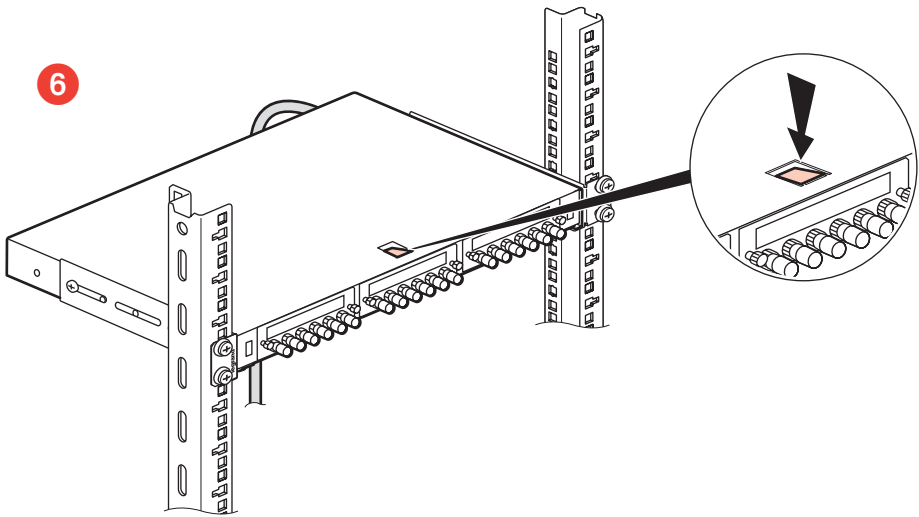
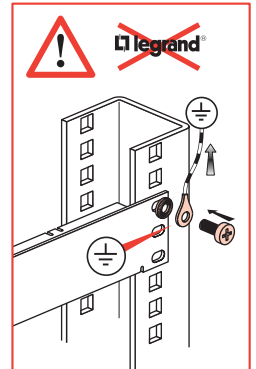
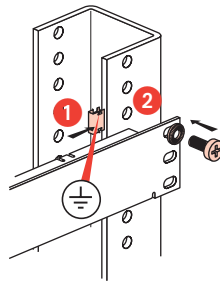

⚠ Consignes de sécurité

Avant toute intervention, couper le courant.
Respecter strictement les conditions d'installation et d'utilisation.

(FR LU BE)

⚠ Veiligheidsvoorschriften

Onderbreek voor enige ingreep de stroom.
Neem de installatie- en gebruiksvoorwaarden nauwgezet in acht.

(NL BE)

⚠ Sicherheitshinweise

Vor jeglichem Eingriff die Spannungsfreiheit sicherstellen.
Einbau- und Gebrauchsanleitungen sind genau zu beachten.

(DE)

⚠ Safety instructions

Make sure the power supply is disconnected before any intervention.
Strictly comply with instructions for installation and use.

(GB IE)

⚠ Consignas de seguridad

Antes de cualquier intervención, cortar la corriente.
Respetar estrictamente las condiciones de instalación y de utilización.

(ES)

⚠ Instruções de segurança

Antes de qualquer intervenção, cortar a corrente.
Respeitar estritamente as condições de instalação e de utilização.

(PT)

⚠ Συστάσεις ασφαλείας

Πριν από οποιαδήποτε επέμβαση, κόψτε το ρεύμα.
Τηρήστε αυστηρά τις συνθήκες εγκατάστασης και χρήσης.

(GR CY)

⚠ Меры предосторожности

Преди каквото и да е работа по продукта, да се изключи от електрическото захранване.
Задължително е да се спазват условията за инсталиране и употреба

(RU)

⚠ Güvenlik talimatları

Herhangi bir müdahaleden önce, akımı kesiniz.
Yerleşime ve kullanım koşullarına titizlikle riayet ediniz.

(TR CY)