

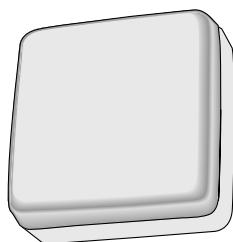

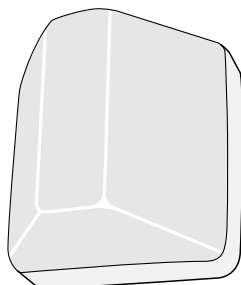











AVR70



AVR72



AVR71

-  FIN Asennusohje
-  SWE Installationsanvisning
-  ENG Installation Instructions
-  CZE Návod k montáži
-  DEU Montageanweisung
-  EST Paigaldusjuhend
-  FRA Notice d'installation
-  ITA Istruzioni per l'installazione
-  LAV Montāžas instrukcija
-  LIT Montavimo instrukcija
-  NOR Installasjonsinstrukser
-  POL Instrukcja montażu
-  RUS Инструкция по монтажу



IP44



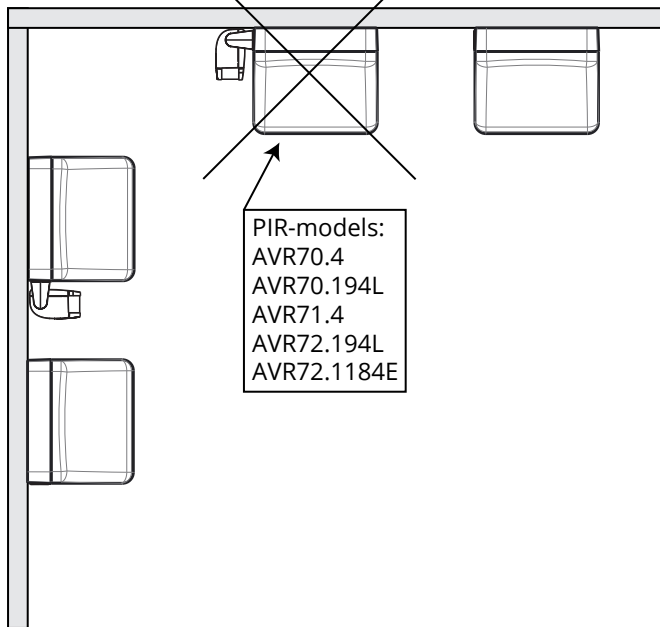
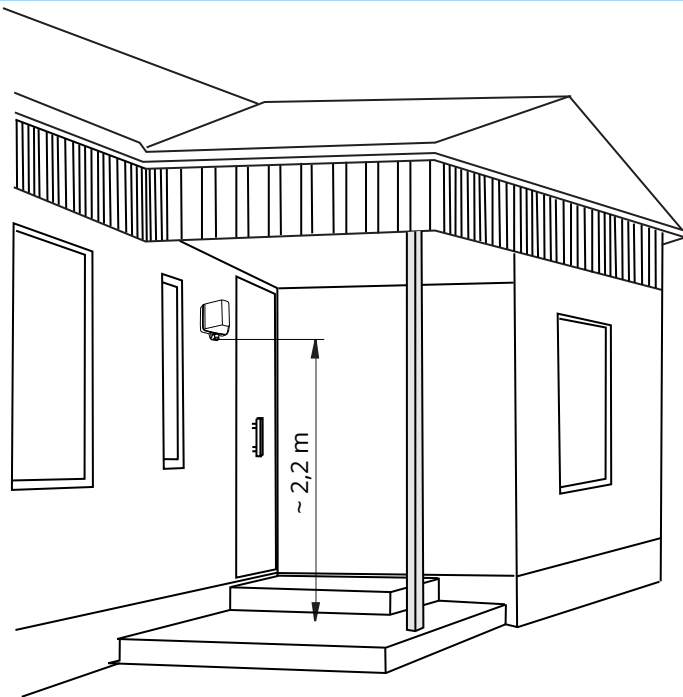

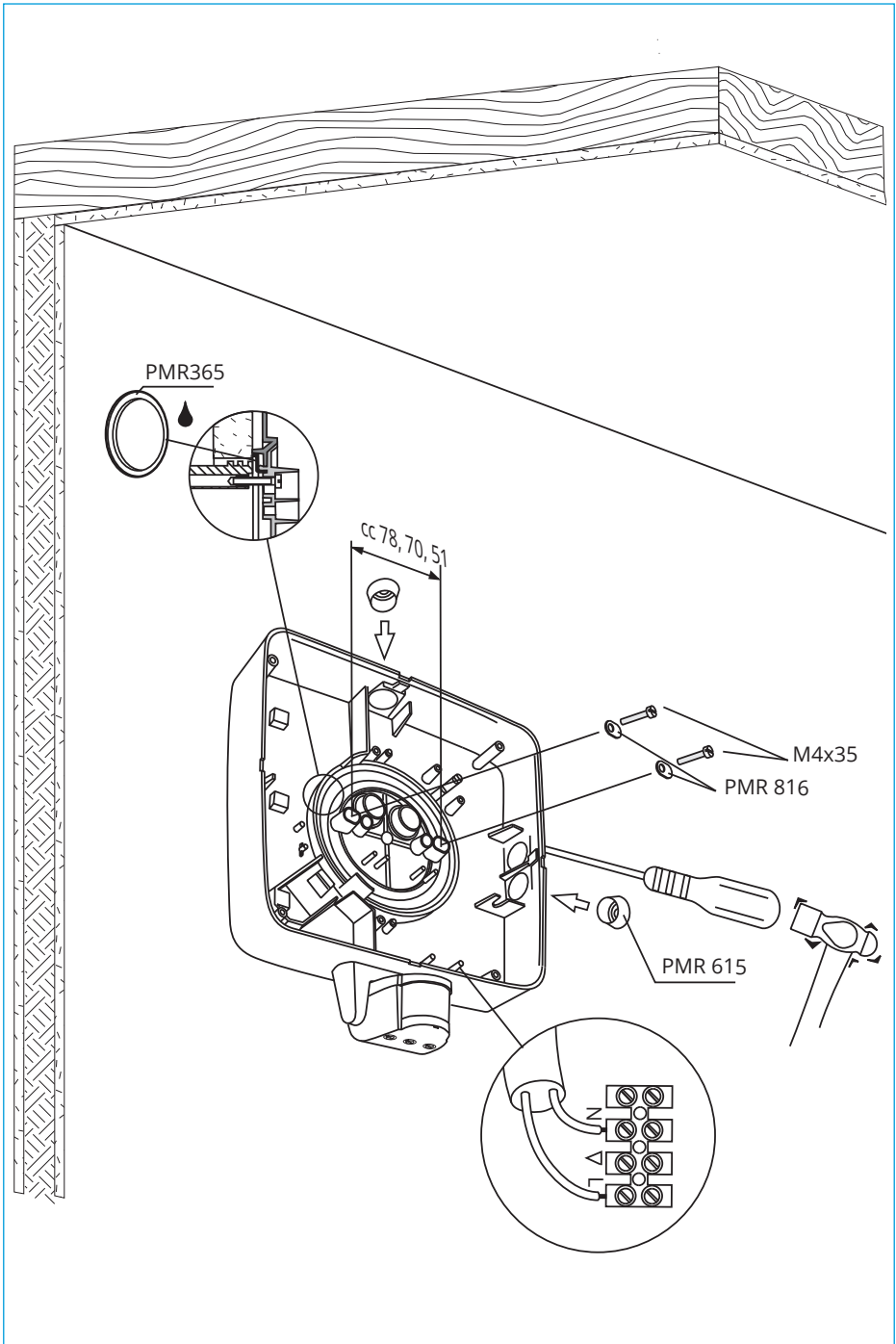



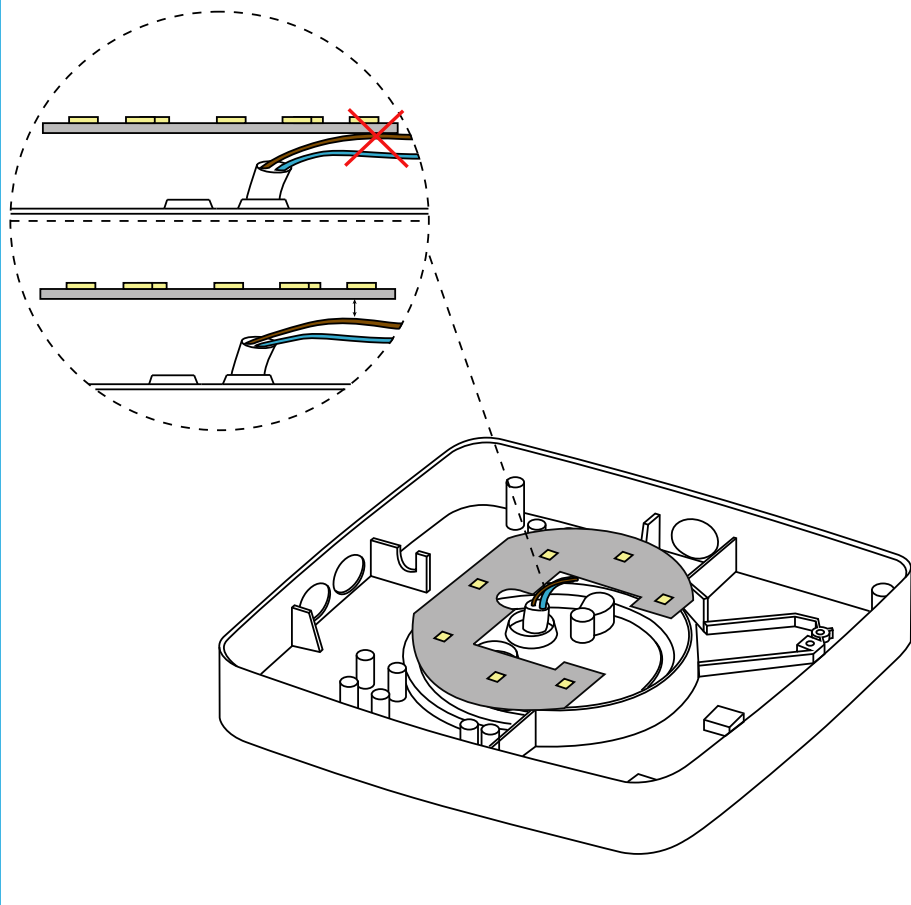

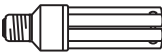

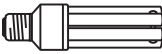
# LED



|                                     |   |  |  |                                  |     |
|-------------------------------------|---|--|--|----------------------------------|-----|
| AVR70.19L<br>AVR71.19L<br>AVR72.19L | 1 x 9W LED  | 86 lm/W  |  | -40°C ... +25°C                  |     |
| AVR70.194L<br>AVR72.194L            | 1 x 9W LED  | 86 lm/W  |  | -30°C ... +25°C                  | PIR |
| AVR70                               | max 75W/E27<br>max 53W Halogen/E27<br>max 23W CFL/E27 <sup>1)</sup> | <br> |  | -30°C ... +30°C<br><br>... +25°C |     |
| AVR71                               | max 75W/E27<br>max 53W Halogen/E27<br>max 23W CFL/E27 <sup>2)</sup> | <br> |  | -30°C ... +30°C<br><br>... +25°C |     |
| AVR70.4                             | max 75W/E27<br>max 53W Halogen/E27<br>max 23W CFL/E27 <sup>1)</sup> | <br> |  | -30°C ... +30°C<br><br>... +25°C | PIR |
| AVR71.4                             | max 60W/E27<br>max 53W Halogen/E27<br>max 23W CFL/E27 <sup>2)</sup> | <br> |  | -30°C ... +30°C<br><br>... +25°C | PIR |

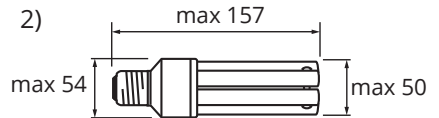
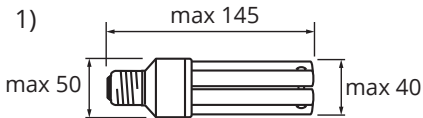

**FIN** Valaisimen saa asentaa vain sähköalan ammattihenkilö. Käytä ainoastaan sytytintyyppiä, valonlähdettä ja tehoa joka valaisimeen on merkitty. Kytke virta pois päältä ennen asennusta tai huoltoa. Tämä asennusohje on säilytettävä paikassa, josta se on saatavilla tulevaa asennusta ja huoltoa varten.

**SWE** Armaturen får endast installeras av en fackkunnig person. Använd endast tändare, ljuskälla och effekt som är märkta på armaturen. Gör kretsen strömlös före installation eller service. Denna intallationsanvisning bör sparas och finnas tillgänglig vid framtida installation eller service.

**ENG** The luminaire must be installed by a qualified person. Use only starters, light sources and rated wattages as marked in the luminaire. Switch off the current before installation or service. This installation instruction must be kept available for future installation and maintenance.

**CZE** Montáž svítidla může provádet pouze pracovník s odrovidaji kvalifikaci pouzitelině startery, světline zdroji a napeti jsou uvedeny na svítidli. Prld instalaaci nebo opravou svítidla vyphenetl privdo proudu. Tento návod k montázi uchovejie pro další povziti.

**DEU** Die montage darf nur durch qualifizierte elektriker vorgenommen werden. Nur die anzündertypen und die auf der leuchte angegebene lichtquelle und leistung verwenden. Vor montage und wartung den strom abschalten. Montageanleitung für spätere wartungsarbeiten aufbewahren!

**EST** Valgustit tohib ühendada vaid nõutava kutseoskusega isik. Kasuta üksnes valgustile märgitud võimsusega starterit ja valgusallikat. Lülita vool välja enne paigaldus- või hooldustöid. Käesolevat paigaldusjuhendit tuleb säilitada ning see peab olema saadaval ka edaspidiste paigaldus- ja hooldustööde ajal.

**FRA** La pose doit être faite par un électricien professionnel. Les starters, les types et puissances de lampes utilisées doivent être strictement conformes aux spécifications indiquées à l'intérieur du luminaire. Couper l'alimentation avant l'installation et pendant toute l'intervention. Conserver la notice pour les opérations de maintenance futures.

**ITA** Il dispositivo di illuminazione va installato da un elettricista professionista. Usare esclusivamente le tipologie di starter, di lampada e il wattaggio indicato sul dispositivo. Spegner la corrente prima di montare il dispositivo o effettuare riparazioni. Conservare le istruzioni per futuri interventi di manutenzione o eventuali nuove installazioni.

**LAV** Gaismekla montazu var veikt tikai attiecīgas kvalifikācijas strādnieks. Driest izmantot tikai tadu palaišanas iekartu, gaismas avotu un ta jaudu, kada ir noradita uz gaismekla. Prims montazas vai remonta ir jaatsledz strava. Dota montazas instrukcija ir jasaglaba turpmakajiem montazas vai apkalpošanas darbiem.

**LIT** Montazo darbus gali atlikti tik darbuotojas, turintis atitinkama kvalifikacija. Naudoti tik ant šviestuvo nurodytus paleidziancius itaisus, šviesos šaltinius ir galingumus. Atjungti itampa prieš montaza ar remonta. Šia instrukcija saugoti ir ja naudotis ateityje, atliekant montazo ir remonto darbus.

**NOR** Armaturen må kun installeres av person med tilstrekkelig yrkeskunnskap. Anvend kun tennere, lyskilder og merket wattstyrke som angitt på armaturen. Slå av strømmen før du installerer eller vedlikeholder. Denne bruksanvisningen skal være tilgjengelig for fremtidig vedlikehold.

**POL** Oprawa moze byc instalowana tylko pnez uprawnionego elektryka. Malezy uzywac zaptonnikow oraz zródet sniatla wskazanyth w opisie. Pned instalowaniem lub obstuga nalezy odtaczyc zosilanie. Instrukcje nalezy zachowac.

**RUS** Светильник может устанавливать только человек, обладающий достаточной профессиональной квалификацией. Отключить ток до начала монтажа или обслуживания. Эту инструкцию сохранять и в дальнейшем применять при монтаже и обслуживании. Применять только указанное на светильнике зажигающее устройство и лампы, указанной мощности.

#### СВЕДЕНИЯ О СЕРТИФИКАЦИИ

Товар сертифицирован и соответствует требованиям нормативных документов.

#### ЗАВОДЫ-ИЗГОТОВИТЕЛИ:

Ensto Building Systems Finland Oy  
(Энсто Билдинг Системс Финлянд Ой)  
Ensio Miettisen katu 2 (Ул. Энсио  
Меттисен, 2)  
P.O.BOX 77 (А/я 77)  
06101 Porvoo (06101 Порвоо)  
Finland (Финляндия)  
Тел. +358 204 76 21

#### ИМПОРТЕР:

ООО «Энсто Билдинг Системс»  
Россия, 198205 Санкт-Петербург  
Таллинское шоссе (Старо-Паново),  
дом 206, литер А, офис 2128  
тел. (812) 325 93 40  
факс (812) 325 93 41

[www.ensto.ru](http://www.ensto.ru)

Ensto Building Systems Oü  
(Энсто Билдинг Системс Ой)  
Pärnuvälja 9  
72720 Paide,  
Estonia (Эстония)





# ENSTO

Ensto Building Systems Finland Oy  
Ensio Miettisen katu 2, P.O. Box 77  
FIN-06101 Porvoo, Finland  
Tel. +358 204 76 21  
[www.ensto.com](http://www.ensto.com)

