

2

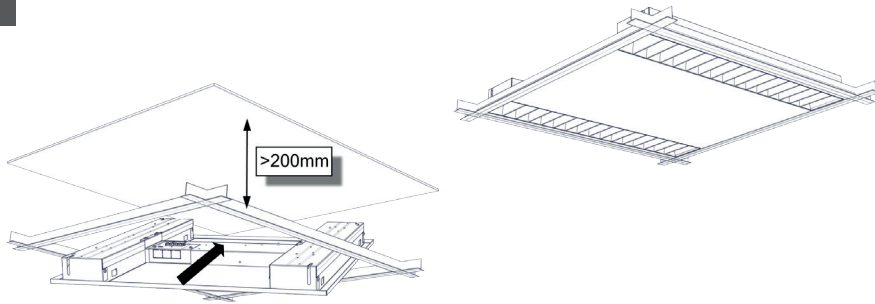

3

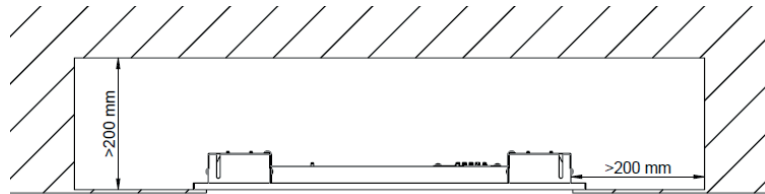
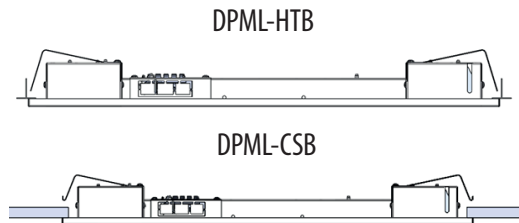

Tarvikkeet / Tilbehör / Accessories / Accessoires / Accessori / Lisatarvikud / Аксессуары

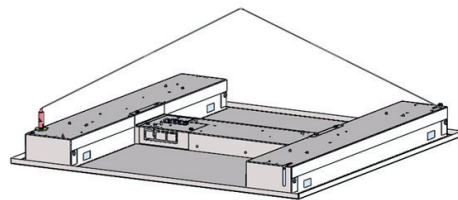

DPML-SECURE

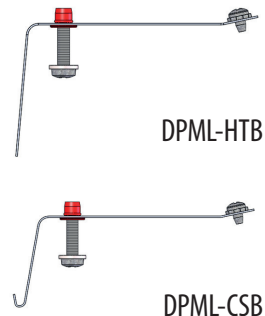

DPML-HTB

DPML-CSB

KÄYTTÖOHJE
BRUKSANVISNING
INSTRUCTION MANUAL
INSTRUCTION D'INSTALLATION

ISTRUZIONI PER L'INSTALLAZIONE
PAIGALDUSJUHEND
MONTAGEANWEISUNG
РУКОВОДСТВО ПО МОНТАЖУ

DPML



Valaisimen asennuksen saa suorittaa vain riittävän ammattitaidon omaava henkilö. Asennuksessa on noudatettava vallitsevia asennusmääräyksiä. Virta on kytkettävä aina pois ennen asentamista tai huoltotoimenpiteitä. Jos valaisin vikaantuu, ottakaa yhteys ammattihenkilöön tai valmistajan asiakaspalveluun. Valaisimessa olevan tyyppitarran merkintöjä on noudatettava.



Endast en behörig elektriker för göra installationen. Installationen måste uppfylla gällande bestämmelser. Gör kretsen strömlös före installation eller service. Om produkten inte fungerar kontakta behörig elektriker eller tillverkaren. Använd endast den ljuskälla och effekt som är märkt på armaturen.



Only a professional electrician is allowed to do the installation. The electrical installation must comply with the prevailing installation regulations. Switch off the current before installation or service. If the luminaire is not working, please contact professional electrician or manufacturer's customer service. Use the ratings as marked in the type label of the luminaire.



La pose doit être faite par un électricien professionnel. Les starters, les types et puissances de lampes utilisés doivent être strictement conformes aux spécifications indiquées à l'intérieur du luminaire. Couper l'alimentation avant l'installation et pendant toute l'intervention. Conserver la notice pour les opérations de maintenance futures.



Il dispositivo di illuminazione va installato da un elettricista professionista. Usare esclusivamente le tipologie di starter, di lampada e il wattaggio indicato sul dispositivo. Spegner la corrente prima di montare il dispositivo o effettuare riparazioni. Conservare le istruzioni per futuri interventi di manutenzione o eventuali nuove installazioni.



Valgusti paigaldust võib teostada ainult vastava ala spetsialist. Valgusti paigaldusel tuleb jälgida üldisi elektriseadmete paigaldamise eeskirju. Enne Valgusti paigaldust või hooldust kontrolli, et elekter oleks alati välja lülitatud. Valgusti rikke korral võta ühendust spetsialistiga või tootja Klienditoeaga. Paigaldamisel jälgi tooteetiketil olevaid tingimärke ja juhiseid.



Die Montage darf nur durch qualifizierte Elektriker vorgenommen werden. Vor Montage und Wartung den Strom abschalten. Bei Störungen der Leuchte wenden Sie sich bitte qualifizierte Elektriker oder Hersteller an. Auf dem Typenschild angegebenen Werte übereinstimmen.



Светильник может устанавливать только человек, обладающий достаточной профессиональной квалификацией. Электрическая установка должна отвечать действующим правилам электрических установок. Отключить ток до начала установки или обслуживания. При обнаружении неисправности светильника обращайтесь только к специалисту с необходимой квалификацией и достаточными профессиональными навыками или сервисную службу производителя. Применять только указанное на этикетке светильника маркировки.



IP20    
3x2,5mm²
5x2,5mm²
LINECT®

