

EMDX³ - Single Phase Din Rail Energy Meter

1 module

Cat.Nos: 700040-700041-700042-700043-700044

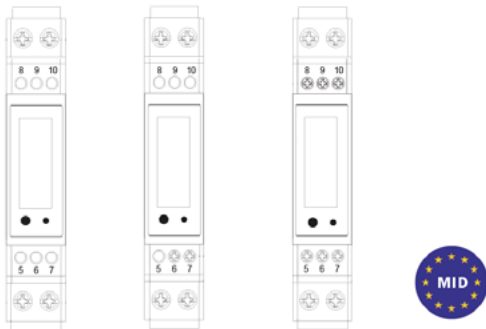

1. USE

The energy-meters are used to measure single-phase applications like residential, utility and industrial. The unit measures and displays various important electrical parameters. It is equipped with a white back-lighted LCD screen for perfect reading (only LCD for Basic version). Bi-directional energy measurement makes it a good choice for solar PV energy metering. The compact design and din rail installation provides an easy and economical solution for your metering demand.

2. RANGE

Cat. Nos	Version	Display	Measurement	Outputs
700040	Basic	LCD	kWh	No
700041	Pulse	LCD with Backlight	kWh	Pulse
700042	Pulse	LCD with Backlight	kWh	Pulse
700043	ModBus	LCD with Backlight	Multi-parameters	Pulses & RS485
700044	ModBus	LCD with Backlight	Multi-parameters	Pulses & RS485

3. INSTALLATION

3.1 Fixing

On IEC/EN 60715 symmetric rail or DIN 35 guide.

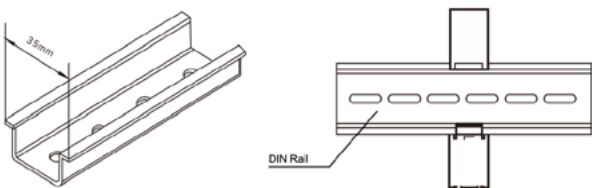

For fastening the device on the DIN rail: 5,5 mm flat screwdriver (from 4 to 6 mm).

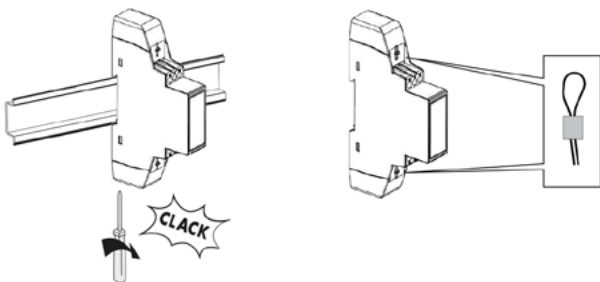

3.2 Operating position

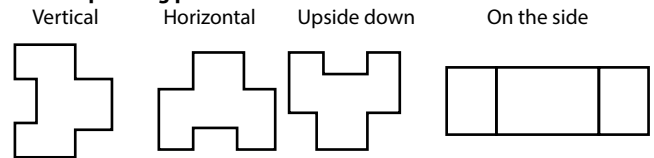

4. DIMENSIONS (mm)

1 module DIN 43880
 Dimensions: 18 x 64 x 118 (W x H x D)
 Weight: 0,1 kg.
 Packaged volume: 0.20 dm³.

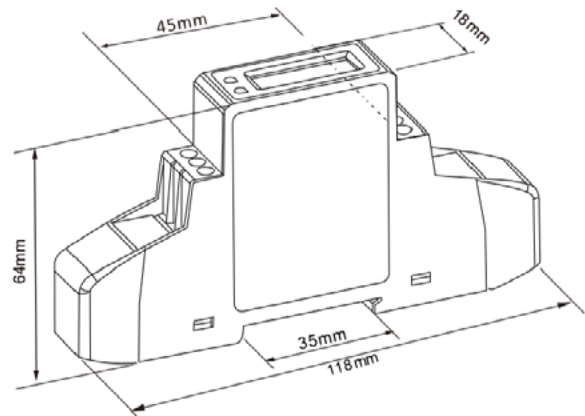

5. CONNECTION

5.1 Wiring diagrams

700040

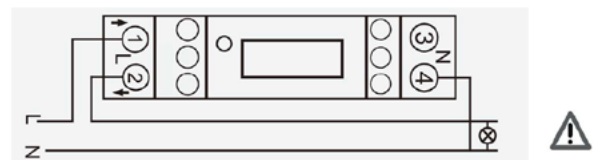

700041

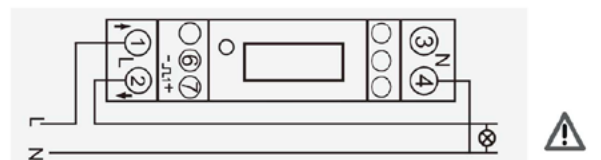

5. CONNECTION (continued)

5.1 Wiring diagrams (continued)

700042

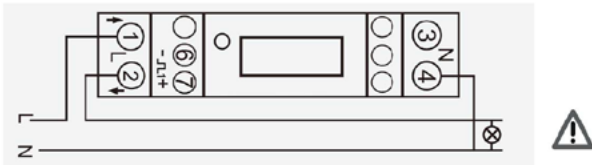

700043

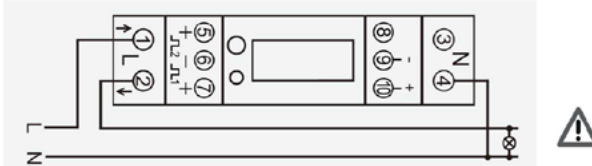

700044

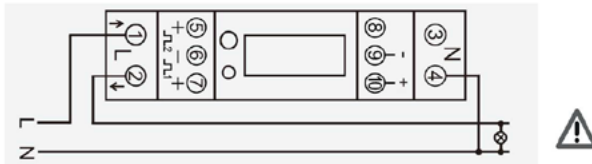

 1 - 2 3 - 4	8 mm MAX 1 x 10 mm ²	max 1,5 Nm 4mm PZ1
	5 mm MAX 1 x 0,5 mm ² 1 x 1,5 mm ²	max 0,2 Nm 3mm PZ0

5.2 Protection of the device

By means of thermal-magnetic circuit breaker.

6. TECHNICAL CHARACTERISTICS

6.1 Display

Start-up Screens

When it is powered on, the meter will initialize and do self-checking. After the self-checking program, the meter screen will display the total active energy (kWh).

Scroll Display by Button

There is a button on the front of the meter. After initialization and self-checking program, the meter display the measured values. The default page is total kWh. If the user wants to check other information, he needs to press the scroll button on the front panel.

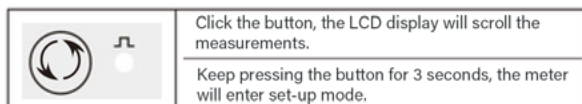

The display of each model:

- 700040/700041/700042:

Total active energy in kWh

- 700043/700044:

Total active energy in kWh -> Imported active energy in kWh -> Exported active energy in kWh -> Total reactive energy in kVArh -> Phase to neutral voltage -> Current of phase -> Instantaneous active power in kW -> Frequency -> Power factor -> Address -> Baud rate -> Parity bit -> Stop bit

6.2 Electric characteristics

Voltage AC (Un)	230 V
Voltage range	176-276 V~ (Basic/Pulse vers.) 100-277 V~ (Modbus vers.)
Current input	0.15-5 (45) A (Max. 45 A)
Voltage Circuit	< 2 W/10 VA
Current Circuit	< 1 VA
Frequency	50/60 Hz
AC voltage withstand	4 kV for 1 minute
Impulse voltage withstand	6 kV~1.2uS waveform
Overcurrent withstand	30 Imax for 0.01 s
Pulse output 1	1000/100/10/1imp/kWh/kVArh (conf.)
Pulse output 2	1000 imp/kWh (no conf.)
Max. Reading	99999.9 kWh/kVArh

Accuracy (IEC/EN61557-12)

Voltage	cl. 0.5
Current	cl. 0.5
Frequency	cl. 0.2
Power factor	cl. 1
Active power	cl. 1
Reactive power	cl. 1
Apparent power	cl. 1

Environment

Reference temperature (IEC/EN 62052-11)	23 °C ± 2 °C
Installation category	CATIII
Relative Humidity	0 to 95%, non-condensing
Altitude	Up to 2000 m
Location	Dry
Warm up time	3 s

6.3 Mechanical characteristics

Protection class:

Terminal protection index against solid bodies and liquids: IP20 (IEC/EN 60529).

Housing protection index against solid bodies and liquids: IP51 (IEC/EN 60529).

Material: Self-extinguishing UL94V-0

Class II: Front panel with cover plate

Level of pollution: 2

Protection class against external mechanical impacts: IK02 (IEC/EN 62052-31).

Mechanical environment: M1

Electromagnetic environment: E2

6.4 Climatic characteristics

Operating room temperatures:

T min. = - 40 °C; T max. = + 70 °C

Storage room temperatures:

T min. = - 40 °C; T max. = + 80 °C

6.5 Diagnostic

Current output diagnostic: Open circuit.

Voltage output diagnostic: Low output load.

7. COMMUNICATION

The meter is equipped with pulse output, which is fully isolated from the inside circuit. That generates pulses in proportion to the measured energy. The pulse output is polarity dependent, passive transistor output requiring an external voltage source for correct operation.

For this external voltage source, the voltage shall be 5-27 V DC, and the maximum input current shall be 27 mA DC.

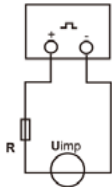

ATTENTION: Pulse output must be fed as shown in the wiring diagram on the left. Scrupulously respect polarities and the connection mode. Opto-coupler with potential-free SPST-NO Contact.

Contact range: 5~27 VDC max.
Max. current input: 27 mA DC

Pulse output for 700041/700042:

Pulse constant: 1000 imp/kWh
Pulse width: 80 ms

Pulse output for 700043/700044:

ModBus vers. provide two pulse outputs. Both pulse outputs are passive type.

Pulse output 1 is configurable. The pulse output can be set to generate pulses to represent total/import/export kWh or kVAh.

The default is export kWh.

Pulse width: 50(default)/100/200 ms.

The pulse constant can be set to: 1000(default)/100/10/1imp/kWh/kVAh.

Pulse output 2 is non-configurable. It is fixed to import kWh.

The constant is 1000imp/kWh. Post width: 100ms.

RS485 Output for 700043/700044:

The meter provides a RS485 port for remote communication. Modbus RTU is the protocol applied. For Modbus RTU, the following RS485 communication parameters can be configured via Modbus communication or from the Set-up Mode.

Baud rate: 2.4 k, 4.8 k, 9.6 k, 19.2 k, 38.4 kbps

Parity: None/Even/Odd

Stop bits: 1 or 2

Modbus Address: 001 to 247

Default parameters for communication:

- Baud rate: 19.2 kbps

- Parity: Even

- Stop bit: 1

- Modbus address: 0 x 05

8. STANDARDS AND REGULATIONS

European Directives:

2014/30/EU

2014/32/EU

2014/35/EU

According to the standard:

Low voltage Directive IEC/EN 61010-1

EMC compatibility: EN/IEC 62052-11 / EN 50470-3

Active energy: Class 0.5 Wh (EN 62053-21)

Class C (EN 50470-3) (MID version)

Reactive energy: Class 2 varh (EN 62053-23)

Respecting the environment - Conformity with CEE Directives:

Compliance with the 2011/65/EU Directive, as modified by the 2015/863/EU Directive (RoHS), on the restriction of the use of certain hazardous substances in electrical and electronic equipment. Conformity with the REACH Regulation (1907/2006): at the date of publication of this document no substance in the annex XIV is found in these products.

RAEE Directive (2012/19/EU): the sale of this product includes a contribution to the appointed environmental bodies of each European country in charge of handling, at the end of their life, the products falling within the scope of the EU Directive on Electrical and Electronic Equipment Waste.

Plastic materials:

Plastic materials without Halogens.

Parts marking according to standards ISO 11469 and ISO 1043.

Packaging:

Packaging designed and produced in accordance with Decree 98-638 of 20/07/98 and Directive 94/62/CE.

