

**Three-phase counter, direct connection 125
A, 6 modules, Modbus RS485 output - MID**Cat. N°:
F41DM125

Contents	Pages
1. Description - Use.....	2
2. Range	2
3. Overall dimensions.....	2
4. Preparation - Connection.....	2
5. General characteristics.....	3
6. Compliance and approvals.....	6
7. Communication	6

Three-phase counter, direct connection 125 A, 6 modules, Modbus RS485 output - MID

Cat. N°:
F41DM125

1. DESCRIPTION - USE

Three-phase active and reactive energy meter.
Measures the electric power consumed by a three-phase circuit downstream of the power distribution metering.
Displays the energy consumption in kWh and kvarh.

2. RANGE

. Cat. No F41DM125: 6-modules (107,2 mm), three-phase meter, pulse and Modbus RS485 output, self-powered on the measurement terminals. MID compliant

Rated currents:

- . Starting current, I_{st} : 40 mA
- . Minimum current, I_{min} : 50 mA
- . Transitional current, I_{tr} : 1 A
- . Reference current, I_{ref} : 10 A
- . Maximum current, I_{max} : 125 A

Rated voltage and frequency:

- . Three-phase reference voltage: 3x230V~/3x400V~ ± 15%
- . Fn: 49...51 Hz, 59...61Hz

Auxiliary supply:

- . Self-supplied on the measurement terminals (V1-N)

3. OVERALL DIMENSIONS

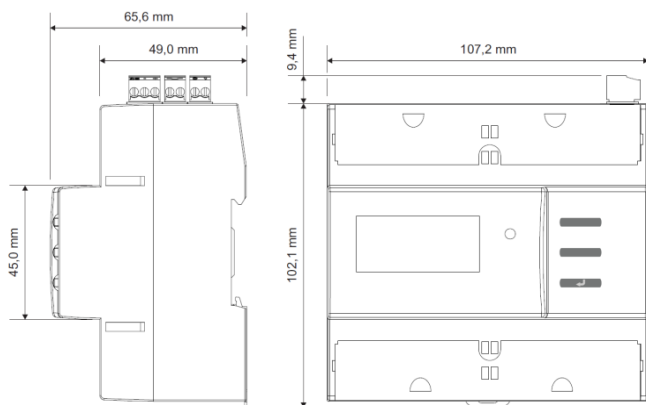

4. PREPARATION - CONNECTION

Fixing:

- . On symmetrical EN/IEC 60715 rail or DIN 35 rail.

Operating positions:

- . Vertical,
- . Horizontal,
- . Upside down,
- . On the side



Terminals:

- . Terminals depth: 8 mm.
- . Stripping length: 8 mm

4. PREPARATION - CONNECTION (continued)

Screw head:

- . Voltages connection terminals (V1, V2, V3): Slotted and Pozidriv
- . Neutral connection terminal (N): Slotted
- . Terminal blocks in the upper part of the meter (input, pulse output and RS485 bus): Slotted

Recommended tightening torque:

- . Voltages connection terminals (V1, V2, V3): 3 Nm
- . Neutral connection terminal (N): 1 Nm
- . Terminal blocks in in the upper part of the meter (input, pulse output and RS485 bus): 0,2 Nm

Max. tightening torque:

- . Voltages connection terminals (V1, V2, V3): 4 Nm
- . Neutral connection terminal (N): 1,2 Nm
- . Terminal blocks in in the upper part of the meter (input, pulse output and RS485 bus): 0,3 Nm

Tools required:

- . Voltages connection terminals (V1, V2, V3): Flat screwdriver 6 mm or Pozidriv PZ2
- . Neutral connection terminal (N): Flat screwdriver 4 mm
- . Terminal blocks in in the upper part of the meter (input, pulse output and RS485 bus): Flat screwdriver 2,5 mm
- . For fixing the device on the DIN rail: flat screwdriver 5.5 mm (max. 6 mm).

Connectable section:

- . Copper cables.
- . Voltages connection terminals (V1, V2, V3):

	Without ferrule	With ferrule
Rigid cable	1 x 4 to 50 mm ²	-
Flexible cable	1 x 4 to 35 mm ²	1 x 4 to 35 mm ²

ATTENTION: for safety reasons, it is compulsory not to exceed 4 A/mm² as current density in the input terminals.

- . Neutral connection terminal (N):

	Without ferrule	With ferrule
Rigid cable	1 x 4 to 16 mm ²	-
Flexible cable	1 x 4 to 16 mm ²	1 x 4 to 16 mm ²

- . Terminal blocks in in the upper part of the meter (input, pulse output and RS485 bus):

	Without ferrule	With ferrule
Rigid cable	1 x 0,2 to 1 mm ²	-
Flexible cable	1 x 0,2 to 1 mm ²	1 x 0,2 to 1 mm ²

Three-phase counter, direct connection 125 A, 6 modules, Modbus RS485 output - MID

Cat. N°:
F41DM125

4. PREPARATION - CONNECTION *(continued)*

Terminal protection:

. Voltage terminals are protected with integrated sealable screw cover.

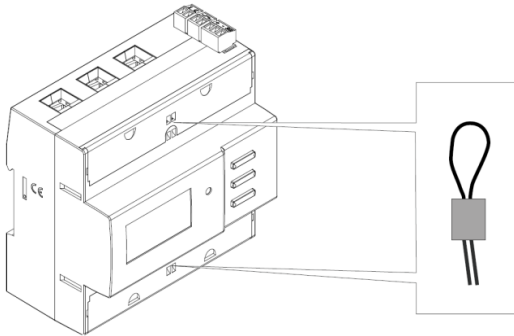

Electrical wiring diagram:

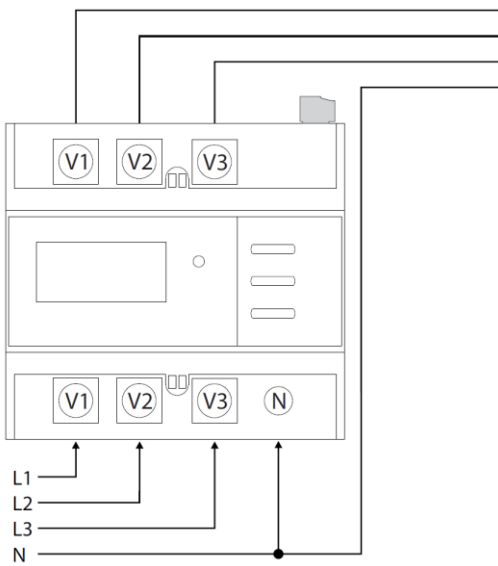

5. GENERAL CHARACTERISTICS

Front face marking:

. By permanent ink pad printing.

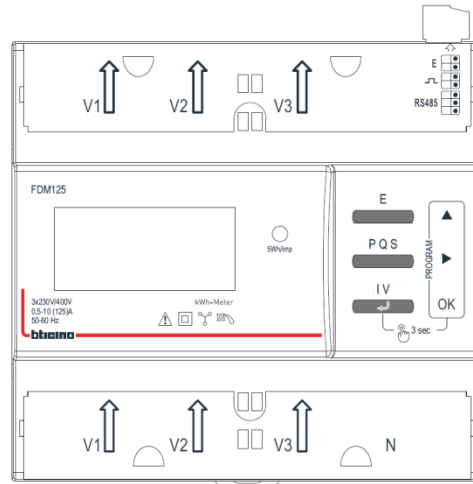

Left face marking:

. By adhesive foil: traceability information



Right face marking:

. By adhesive foil: Electrical wiring diagram

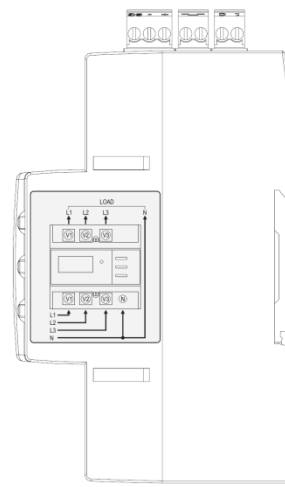

Three-phase counter, direct connection 125 A, 6 modules, Modbus RS485 output - MID

Cat. N°:
F41DM125

5. GENERAL CHARACTERISTICS (continued)

Terminals marking:

- . By permanent ink pad printing.
- . Double tariff input terminal block:

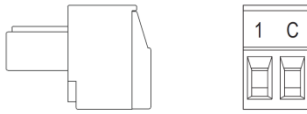

- . Pulse output terminal block:

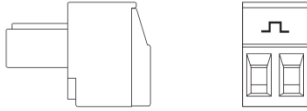

- . Modbus RS485 terminal block:

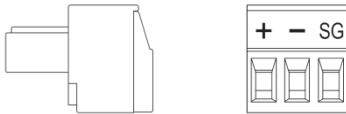

Display:

Type: 8-digits backlighted LCD

Resolution:

Total counters (T): 1 kWh/kvarh

Partial counters: 0,01 kWh/kvarh

Maximum indication:

Total counters (T): 99.999.999 kWh/kvarh

Partial counters: 999.999,99 kWh/kvarh

Metrological LED:

- . Pulse weight: 5 Wh/imp

Programming:

- . Through front keyboard, 3 keys.
- . Access secured by identification code (**default code 1000**); the code can be modified during the programming procedure.

Values display:

- . Manual scrolling by pressing on the front keys.

Accuracy class:

- . Active energy, total and partial: B (EN 50470-1, -3)

Hour Meter:

- . Counting hours and minutes of operation (*resettable counter*)
- . Resolution: 7-digits (5 hours + 2 minutes)
- . Maximum display: 99.999h 59min
- . Count start: three-phase active power "Pn"
- . Programmable value: 0,4...50% Pn - (Pn = three-phase active power, related to 400V and 10A = 6,9kW)

5. GENERAL CHARACTERISTICS (continued)

Digital input:

- . Terminal block is located on the upper part of the meter
- . Digital input, allows switching of energy count on 2 tariffs
- . 2 input terminals with common point (1 - C)
- . Rated voltage: 12-24 VDC, max. 10 mA
- . Inputs wiring:

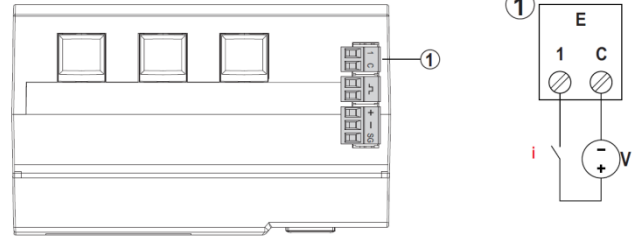

Note: "V" 12-24 VDC, max. 10 mA

RS485 communication port's characteristics:

- . Programmable addresses: from 1 to 247
- . Baud rate: 4,8 - 9,6 - 19,2 kbps
- . Parity bit: none, even, odd
- . Stop bit: 1
- . Galvanically isolated respect to measuring inputs
- . Standard RS485 3 wires, half-duplex
- . Protocol Modbus® RTU
- . Response time (time out question/answer): ≤200 ms

Default configuration:

- . Addresses: 5
- . Baud rate: 19,2 kbps
- . Parity bit: even

Pulse output's characteristics:

- . Optorelays with potential-free SPST-NO contact
- . Type S0 (IEC/EN62053-31)
- . Voltage U_{imp} : max. 27 VAC/DC
- . Current I_{imp} : max. 50 mA
- . Programmable pulse weight, possible values: 1 - 10 (**Default configuration**) - 100 - 1k - 10k - 100k Wh/imp or varh/imp
- . Programmable pulse duration, possible values: 50 - 100 - 200 - 300 - 400 - 500 ms.

Plastic material:

- . Self-extinguishing polyamide.

Ambient operating temperature:

- . Min. = - 5 °C, Max. = + 55 °C.

Ambient storage temperature:

- . Min. = - 25 °C, Max. = + 70 °C.

Device protection:

- . By 125 A circuit breaker

5. GENERAL CHARACTERISTICS *(continued)*

Protection Index:

- . Protection index of terminals against solid and liquid bodies (wired device): IP 20 (IEC/EN 60529).
- . Protection index of the front face against solid and liquid bodies: IP 54 (IEC/EN 60529).
- . Class II, front with faceplate

Impulse withstand voltage:

- . Measuring inputs / RS485 port:
wave 1,2 / 50 μ s 0,5 J: 6kV
alternate current 50 Hz / 1 min.: 4 kV
- . Measuring inputs / Digital Input/Output:
wave 1,2 / 50 μ s 0,5 J: 6kV
alternate current 50 Hz / 1 min.: 4 kV
- . All circuits / earth:
alternate current 50 Hz / 1 min.: 4 kV

Insulation voltage, U_i :

- . 300V Phase-Earth

Pollution degree:

- . 2

Installation category:

- . III

Short-time overcurrent (EN62053-21, EN62053-23):

- . 30 I_{max} for 10 ms

Power consumption in voltage circuit:

- . Max. 1,5 VA (1,5 W) 3-phase

Power consumption in current circuit:

- . Max. 2,5 W for phase

Thermal power dissipated:

- . ≤ 10 W.

Average weight per device:

- . 0,5 kg.

Volume when packed:

- . 1,5 dm³.

6. COMPLIANCE AND APPROVALS

Compliance to standards:

- . Compliance with Directive on electromagnetic compatibility (EMC) n° 2014/30/EU
- . Compliance with low voltage directive n° 2014/35/EU.
- . Electromagnetic Compatibility: Test according to EN/IEC 62052-11
- . Compliance with Directive on Electrical measurement devices (MID) n° 2014/32/EU standards: EN 50470-1, -3
- . Accuracy class:
Active energy accuracy class: B (EN 50470-1, -3).

Environment respect - Compliance with EU directives:

- . Compliance with Directive 2011/65/EU as amended by Directive 2015/863 (RoHS 2) on the restriction of the use of certain hazardous substances in electrical and electronic equipment.
- . Compliance with REACH regulation (1907/2006): at the date of the publication of this document no element of the SVHC substance list (updated on 27/06/2018) is present in these products.
- . WEEE directive (2012/19/EU): the sale of this product is subject to a contribution to eco-organisations in each country responsible for managing end-of-life products in the field of application of the European Waste Electronic and Electrical Equipment Directive.

Plastic materials:

- . Halogens-free plastic materials.
- . Marking of parts according to ISO 11469 and ISO 1043.

Packaging:

- . Design and manufacture of packaging compliant to decree 98-638 of the 20/07/98 and also to directive 94/62/CE.

7.COMMUNICATION

Modbus RS485 wirina diagram:

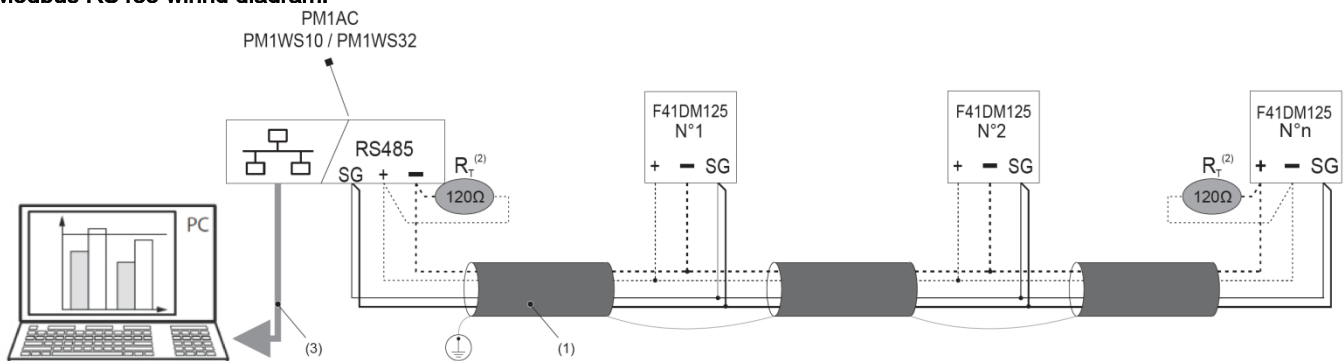

(1) RS485: Prescribed use of Cable Belden 9842, Belden 3106A (or equivalent) for a maximum length of 1000 m, or Category 6 cable (FTP or UTP) for a maximum length of 50 m;

(2) Resistance not furnished

(3) Ethernet: Cat. 6 (FTP/UTP)

Modbus communication tables

- . Modbus communication tables are available at <http://www.bticino.com/>