

SEANO™ ROTARY DIMMER 300W ALL CHARGES

Cat. No(s): 7 650 40

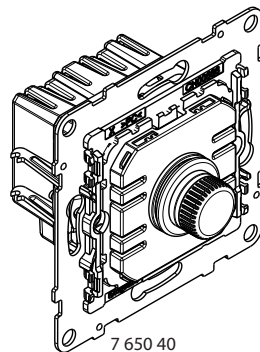

1. USE

Rotary dimming for all types of lamps.
 Can be associated with one or several push buttons, for ON/OFF or dimming control.
 Integrates memory level function: the light switches ON the same level it has been switched OFF.
 Soft-start and soft-stop lighting (2 s).
 Mechanisms to be equipped with plates.

Screw or claw mounting.

2. RANGE

Description	Mechanism only
ROTARY DIMMER 300W ALL CHARGES	7 650 40

3. DISMANTLING

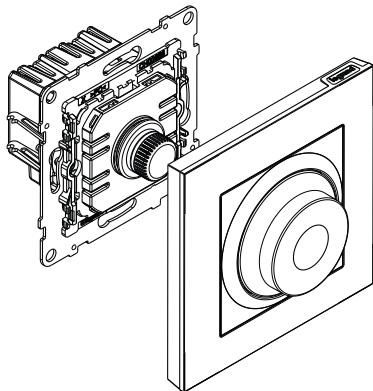

4. DIMENSIONS (mm)

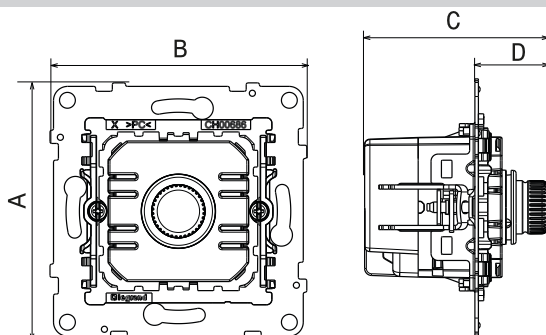

References	A	B	C	D
7 650 40	72,9	72,9	51,9	20,5

5. CONNECTION

4 terminals with screws
 Terminal capacity:
 2 x 2.5 mm²
 Stripping length:
 8 mm

6. INSTALLATION

Simple

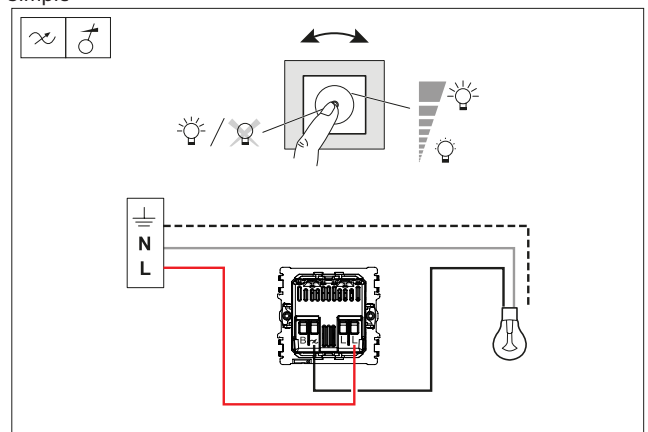

With push buttons

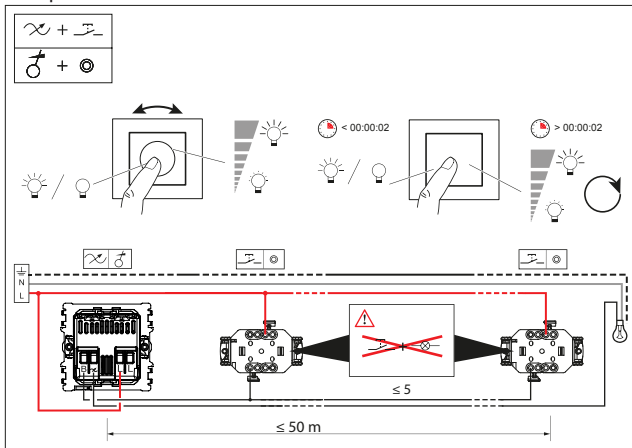

6. TECHNICAL CHARACTERISTICS

■ 6.1 Mechanical characteristics

Protection against solid bodies and liquids: IP 40
Protection against impact: IK 04

■ 6.2 Material characteristics

Polygloss appearance
Colour: - White RAL 9003
- Panited aluminium
- Panited black
- Panited dark grey

Material:

- Front cover: ABS
- Halogen-free
- UV-resistant

Material of the support:

- Metal
- Halogen-free

Self-extinguishing:

850°C/30 s for insulating components holding live parts in place
650°C/30 s for other insulating components.

■ 6.3 Electrical characteristics

Voltage: 100 to 240 V~

Frequency: 50-60 Hz

Standby consumption: 0.2 W

■ Load table

	R	L	C/L	Dimmable	Dimmable LED
200-240V~ 50 / 60 Hz	5.. 300 W	5.. 300 VA	5.. 300 VA	5.. 75 W ≤ 10 x	
100-200V~ 50 / 60 Hz	5.. 150 W	5.. 150 VA	5.. 150 VA	5.. 37 W ≤ 10 x	

■ Setting C or L

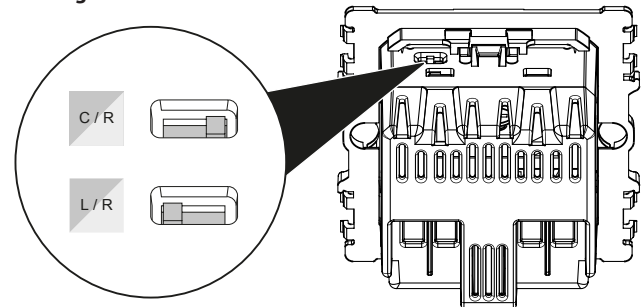

■ 6.4 Climate characteristics

Usage temperature: - 5°C to + 35°C

Storage temperature: - 10°C to + 70°C

7. MAINTENANCE

Surface cleaning with a cloth.

Do not use:

Acetone, tar remover, trichloroethylene.

Maintenance with the following products:

Hexane (EN 60669-1), Methylated spirit, Soapy water, Diluted ammonia, Bleach diluted to 10%, Window-cleaning products, Pre-impregnated-wipes.

Caution: Always test before using other special cleaning products.

8. STANDARDS AND APPROVALS

Compliant with installation and manufacturing standards.

See e. catalogue.