

Surface-mounted equipment 2P+E Schuko socket outlets - Lighting control



1. USE

Socket outlets with protection eclips and lighting control.

2. RANGE

		References : Designations	
Flush-mounting complete		2P+T and two-way socket Vertical	0 860 67L

3. OVERALL DIMENSIONS (mm)

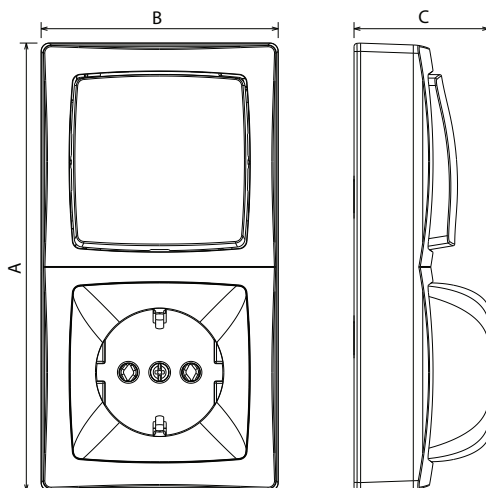

	A	B	C
Flush-mounting complete	136	72	40.9

4. CONNECTION

Type of terminals: automatic
Terminal capacity: 1.5 mm² - 2.5 mm² (1 or 2 conductors)
Stripping length: 12 mm

5. TECHNICAL CHARACTERISTICS

■ 5.1 Protection index

Protection against solid bodies and liquids: IP 31D

Protection against impact: IK 04

■ 5.2 Material characteristics

Front plate, support, rocker: ABS

Mechanism: PC

UV-resistant

Halogen-free

Self-extinguishing:

850°C/30 s for insulating components holding live parts in place.

650°C/30 s for other insulating components.

■ 5.3 Electrical characteristics

Voltage: 250 V~

Current: Socket: 16 A

: Lighting control 10 AX

Maximum power on lamps with integrated ballast (LED lamps and compact fluorescent): 100 W

Frequency: 50 Hz

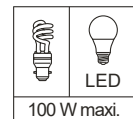

■ 5.4 Climate characteristics

Usage temperature: - 10° à + 40° C

Storage temperature: - 25° C à + 60° C

6. CLEANING

Surface cleaning with a cloth.

Do not use: acetone, tar remover, trichloroethylene.

Maintenance with the following products: Hexane (EN 60669-1),

Methylated spirit, Soapy water, Diluted ammonia, Bleach diluted to 10%,

Window-cleaning products, Pre-saturated wipes.

Caution: A preliminary test should be carried out if other specific cleaning products are to be used.

7. STANDARDS AND APPROVALS

Compliance with standards of installation and manufacturing.

Refer to e. catalogue.