

DMX-SP 4000 circuit breakers

(PU MP2.10 and MP4.10)

DMX-SP-I 4000 switch disconnectors

References:

6 702 60 / 61 / 62 / 63 / 65 / 66 / 67 / 68;

6 702 70 / 71 / 72 / 73 / 75 / 76 / 77 / 78;

6 696 80 / 81 / 82 / 88 / 84 / 85 / 86 / 87



CONTENTS

PAGES

1. USE.....	1
2. RANGE.....	1
3. DIMENSIONS.....	1
4. OVERVIEW.....	5
5. ELECTRICAL CONNECTIONS.....	5
6. ELECTRICAL AND MECHANICAL CHARACTERISTICS.....	5
7. CONFORMITY.....	9
8. EQUIPMENTS AND ACCESSORIES.....	9
9. CURVES.....	12

Full technical sheet LE13044AA

1. USE

DMX-SP air circuit breakers offer optimal solutions to answer to protection requirements on the origin of the low voltage electrical installation (IEC/EN 60364-1) up to 4000A. Their electric and mechanical robustness, in addition to breaking capacity and chances of accessorizing, are perfectly suited for these requirements.

DMX-SP offer a series of air switch-disconnector ("I" series) also, with high performances of insulation, robustness, closing and withstand capability.

Both series are furthermore developed for increase continuity service looking at the plant energy efficiency and in respect of "green aspects" (see item 7-Conformity).

2. RANGE

DMX-SP 4000 circuit breakers (MP2.10 and MP4.10 electronics)				
Fixed version				
	50kA		65kA	
I _n (A)	3P	4P	3P	4P
3200	6 702 60	6 702 62	6 702 65	6 702 67
4000	6 702 61	6 702 63	6 702 66	6 702 68
Draw-out version (*)				
	50kA		65kA	
I _n (A)	3P	4P	3P	4P
3200	6 702 70	6 702 72	6 702 75	6 702 77
4000	6 702 71	6 702 73	6 702 76	6 702 78

DMX-SP-I 4000 switch disconnectors				
	Fixed version		Draw-out version (*)	
I _n (A)	3P	4P	3P	4P
3200	6 696 80	6 696 82	6 696 84	6 696 86
4000	6 696 81	6 696 83	6 696 85	6 696 87

(*) Draw-out references represent only the mobile part.

To get complete device in draw-out version, it is necessary to combine mobile parts AND fixed base references:

ref. 6 696 12 (draw-out base for 3P versions)

ref. 6 696 13 (draw-out base for 4P versions)

3. DIMENSIONS

3.1 Fixed version

Frontal view

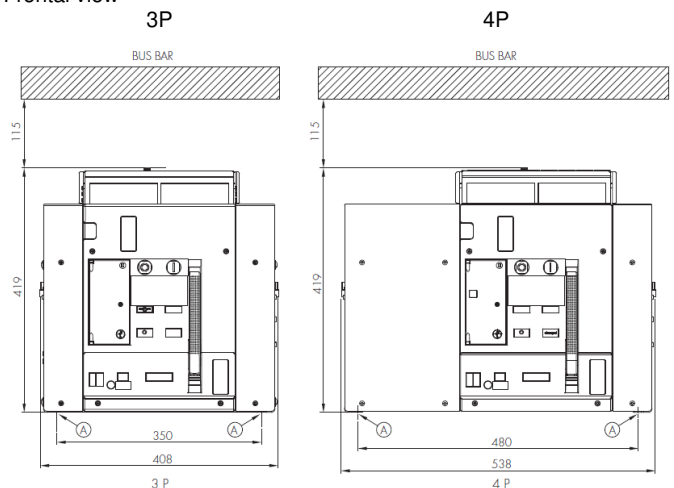

A = fixing point on plate of enclosure

Rear view

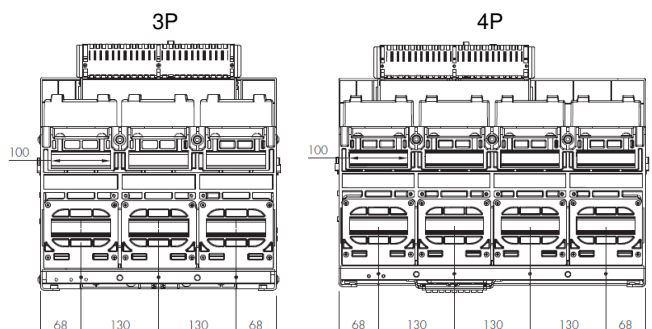

Lateral view

DMX-SP 4000 circuit breakers (PU MP2.10 and MP4.10) DMX-SP-I 4000 switch disconnectors

References:

6 702 60 / 61 / 62 / 63 / 65 / 66 / 67 / 68;

6 702 70 / 71 / 72 / 73 / 75 / 76 / 77 / 78;

6 696 80 / 81 / 82 / 88 / 84 / 85 / 86 / 87

3P - 4P

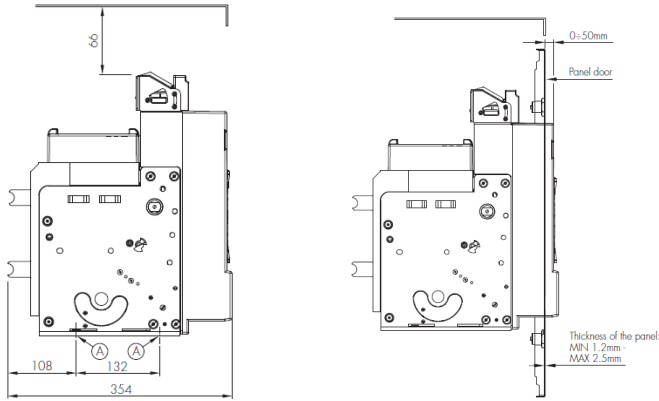

A = fixing point on plate of enclosure

I_{cc} (kA)	≤ 50	≤ 65
"X" max (mm)	300	250

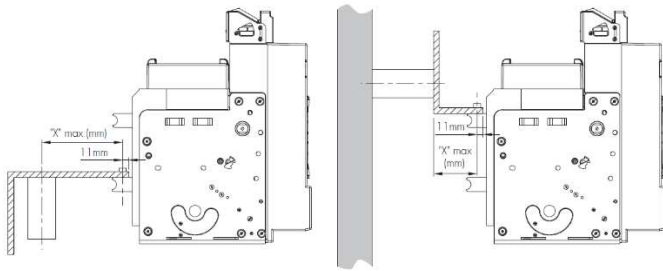

3.2 Draw-out version

Frontal view

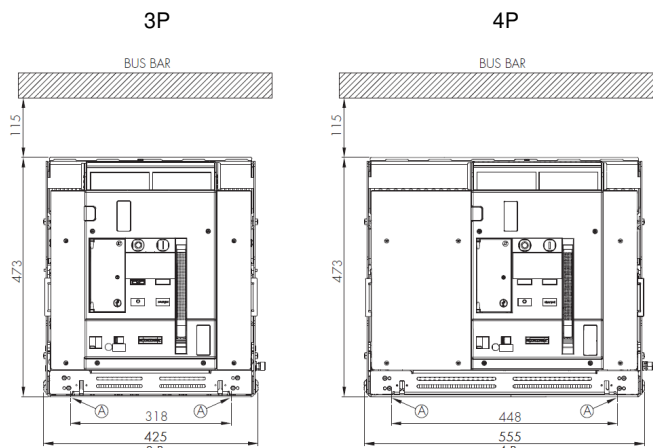

A = fixing point on plate of enclosure

Rear view

- Flat terminals

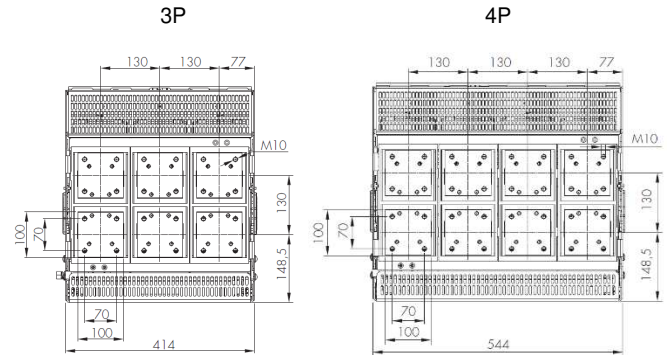

- Horizontal terminals

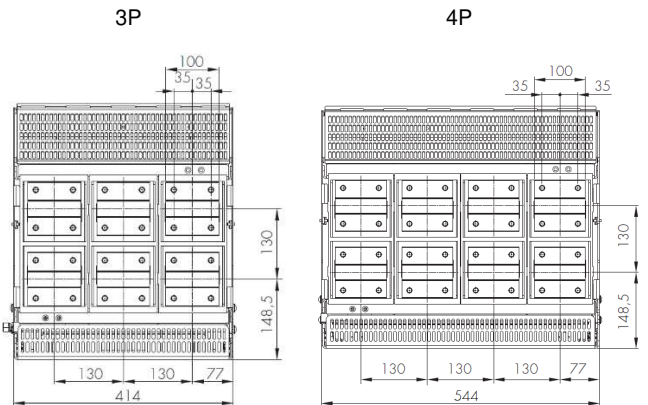

- Vertical terminals

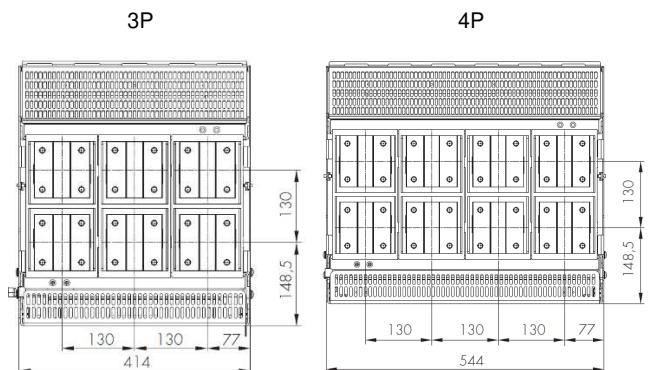

- Horizontal COMB terminals

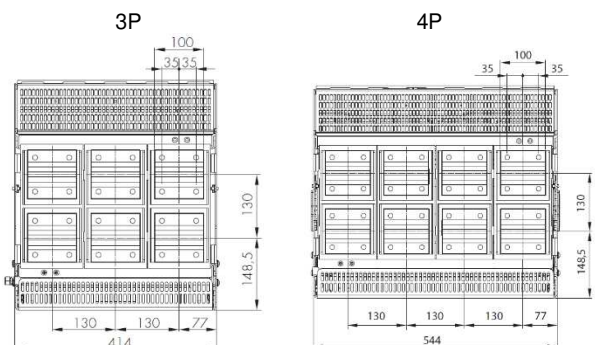

DMX-SP 4000 circuit breakers (PU MP2.10 and MP4.10) DMX-SP-I 4000 switch disconnectors

References:

6 702 60 / 61 / 62 / 63 / 65 / 66 / 67 / 68;

6 702 70 / 71 / 72 / 73 / 75 / 76 / 77 / 78;

6 696 80 / 81 / 82 / 88 / 84 / 85 / 86 / 87

- Vertical COMB terminals

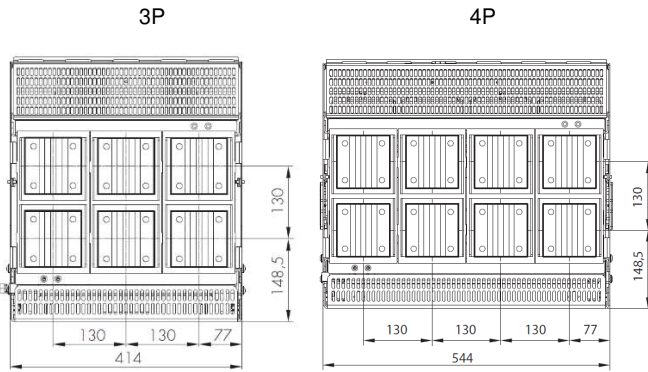

Lateral views

3P - 4P

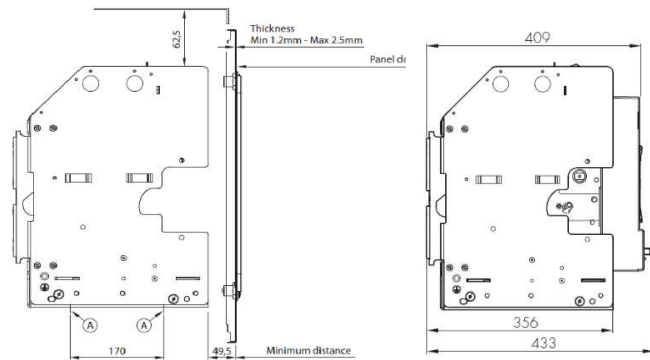

A = fixing point on plate of enclosure

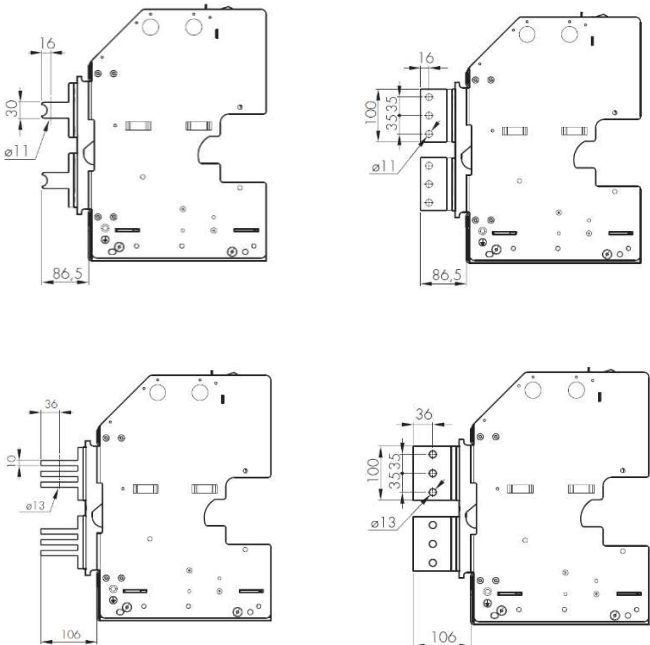

3.3 Rear terminals for fixed version – Flat connection

References	
3P	4P
6 696 14	6 696 15

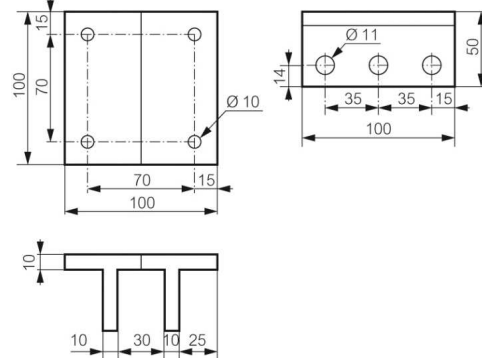
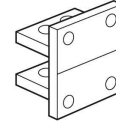

3P

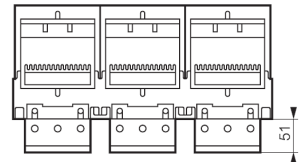
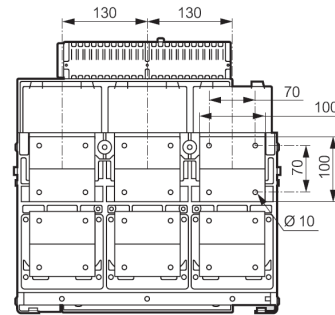

4P

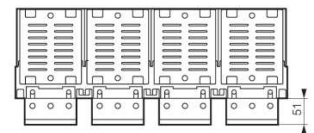
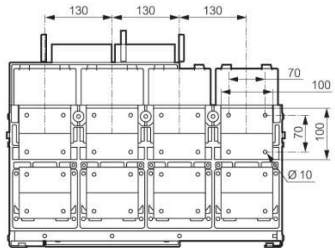

DMX-SP 4000 circuit breakers (PU MP2.10 and MP4.10) DMX-SP-I 4000 switch disconnectors

References:

6 702 60 / 61 / 62 / 63 / 65 / 66 / 67 / 68;

6 702 70 / 71 / 72 / 73 / 75 / 76 / 77 / 78;

6 696 80 / 81 / 82 / 88 / 84 / 85 / 86 / 87

Mounting examples:

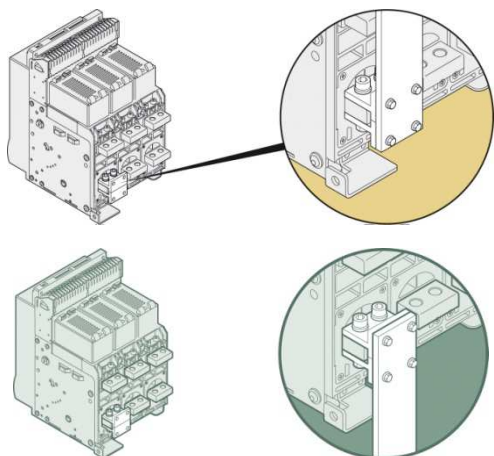

3.4 Rear terminals for fixed version – Vertical connection

References	
3P	4P
0 288 94	0 288 95

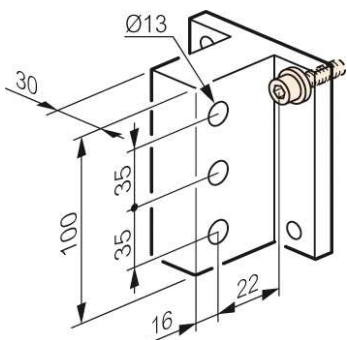

Mounting example:

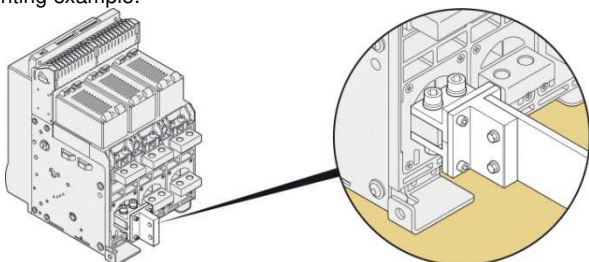

3.5 Rear terminals for Draw-out version – Flat/vertical connection

References	
3P	4P
0 288 94	0 288 95

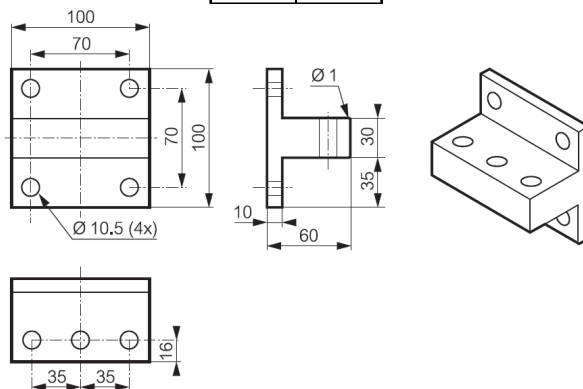

Mounting example:

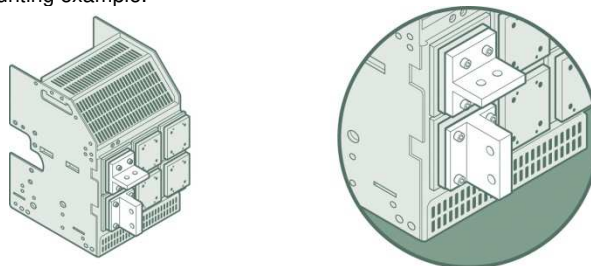

3.6 Terminations support distances – Fixed version

Icc (kA)	≤ 50	≤ 65
*X' max (mm)	300	250

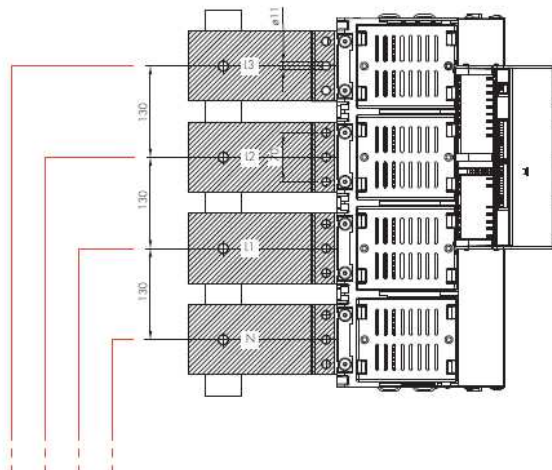
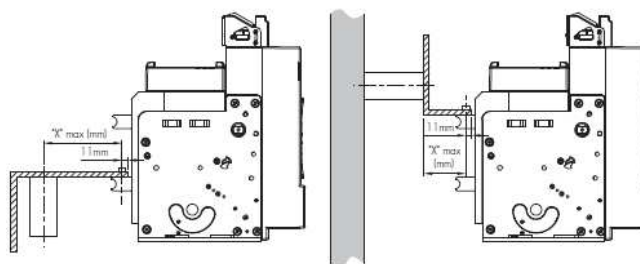

DMX-SP 4000 circuit breakers (PU MP2.10 and MP4.10) DMX-SP-I 4000 switch disconnectors

References:

6 702 60 / 61 / 62 / 63 / 65 / 66 / 67 / 68;

6 702 70 / 71 / 72 / 73 / 75 / 76 / 77 / 78;

6 696 80 / 81 / 82 / 88 / 84 / 85 / 86 / 87

4. OVERVIEW

4.1 Supplied with

ACBs are equipped with auxiliary contacts (1 NO/NC, expandable up to 10); besides:

- Fixed version: equipped with rear terminals for horizontal connections with bars.
- Draw-out version (only mobile part): to complete with the base, to get the complete draw-out version.
- Base for draw-out version: equipped with flat terminals, for connection with bars.

5. ELECTRICAL CONNECTIONS

Use only as a general guideline to select products. Due to extensive variety of switchgear installation shapes and conditions of use, the solution used must always be verified.

If inter-poles air distance is less than 20mm, it's recommended use of phase insulators or insulated bars.

Minimum cross section of COPPER busbars per pole

. DMX-SP and DMX-SP-I fixed and draw-out versions

Rated current (A)	Vertical bars (mm)	Horizontal bars (mm)
3200	3 bars 100 x 10	4 bars 80 x 10
4000	4 bars 100 x 10	5 bars 100 x 10

Minimum cross section of ALUMINIUM busbars per pole

. DMX-SP and DMX-SP-I fixed and draw-out versions

Rated current (A)	Vertical bars (mm)	Horizontal bars (mm)
3200	4 bars 150 x 10	5 bars 150 x 10
4000	5 bars 150 x 10	6 bars 150x10

6. ELECTRICAL AND MECHANICAL CHARACTERISTICS

Circuit breaker

Electrical data refers to IEC/EN 60947-2 standard

	DMX-SP 4000		
	50 kA	65 kA	
Frame current (A)	4000		
Number of poles	3P - 4P		
Rated current I_n (A)	3200 / 4000		
Release type	electronic		
Rated insulation voltage U_i (V)	1000		
Rated impulse withstand voltage U_{imp} (kV)	12		
Rated operational voltage (50/60Hz) U_e (V)	690		
Utilization Category	B		
Rated ultimate short-circuit breaking capacity I_{cu} (kA)	220 / 240 V AC	50	65
	380 / 415 V AC	50	65
	440 / 460 V AC	50	65
	480 / 500 V AC	50	65
	600 V AC	42	50
	690 V AC	42	50
Rated service short-circuit breaking capacity I_{cs} (% I_{cu})	100%		
Rated short-circuit making capacity I_{cm} (kA)	220 / 240 V AC	105	143
	380 / 415 V AC	105	143
	440 / 460 V AC	105	143
	480 / 500 V AC	105	143
	600 V AC	88	105
	690 V AC	88	105
Rated short time withstand current I_{sw} (kA) for t = 1s	220 / 240 V AC	50	65
	380 / 415 V AC	50	65
	440 / 460 V AC	50	65
	480 / 500 V AC	50	65
	600 V AC	42	50
	690 V AC	42	50
Rated short time withstand current I_{sw} (kA) for t = 3s	220 / 240 V AC	36	40
	380 / 415 V AC	36	40
	440 / 460 V AC	36	40
	480 / 500 V AC	36	40
	600 V AC	36	40
	690 V AC	36	40
Individual pole short-circuit current I_{1T} (kA)	220 / 240 V AC	1.2 times the maximum setting of the definite time delay release tripping current (I_{td}) ⁽¹⁾	
	380 / 415 V AC		
	440 / 460 V AC		
	480 / 500 V AC		
	600 V AC		
	690 V AC		
Suitable for isolation	Yes		
Neutral protection (% I_{cs})	0 - 50 - 100		
Endurance (cycles)	mechanical	5000 (w/o maintenance); 10000 (with maintenance)	
	electrical	3000 (w/o maintenance)	
Weight (Kg)	3P - Fixed	59	
	3P - Drawout ⁽²⁾	108	
	4P - Fixed	76	
	4P - Drawout ⁽²⁾	137	
Height (mm)	3P - Fixed	419	
	3P - Drawout	465	
	4P - Fixed	419	
	4P - Drawout	465	
Depth (mm)	3P - Fixed	354	
	3P - Drawout	433	
	4P - Fixed	354	
	4P - Drawout	433	
Width (mm)	3P - Fixed	408	
	3P - Drawout	425	
	4P - Fixed	538	
	4P - Drawout	555	
Temperature	operation	-25°C to +70°C	
	storage ^(*)	-25°C to +85°C	
Maintenance	Yes (see specific guide)		

⁽¹⁾ For more details, please consult Legrand

⁽²⁾ Weights for draw-out devices are to be intended with base

^(*) Storage temperature may be considered -40°C to +85°C, only if using MP2 protection unit type (without LCD screen visualization)

DMX-SP 4000 circuit breakers (PU MP2.10 and MP4.10) DMX-SP-I 4000 switch disconnectors

References:

6 702 60 / 61 / 62 / 63 / 65 / 66 / 67 / 68;

6 702 70 / 71 / 72 / 73 / 75 / 76 / 77 / 78;

6 696 80 / 81 / 82 / 88 / 84 / 85 / 86 / 87

Switch disconnector

Electrical data refers to IEC/EN 60947-3 standard

		DMX-SP-I 4000
Frame current (A)		4000
Number of poles		3P - 4P
Rated current I _e (A)		3200 / 4000
Rated insulation voltage U _i (V)		1000
Rated impulse withstand voltage U _{imp} (kV)		12
Rated operational voltage (50/60Hz) U _e (V)		690
Category of use		AC23A
Rated short circuit making capacity I _{cm} (kA)	220 / 240 V AC	143
	380 / 415 V AC	143
	440 / 460 V AC	143
	480 / 500 V AC	143
	480 / 550 V AC	105
	600 V AC	105
Rated short time withstand current I _{cw} (kA) for t = 1s	220 / 240 V AC	65
	380 / 415 V AC	65
	440 / 460 V AC	65
	480 / 500 V AC	65
	480 / 550 V AC	50
	600 V AC	50
Rated short time withstand current I _{cw} (kA) for t = 3s	220 / 240 V AC	40
	380 / 415 V AC	40
	440 / 460 V AC	40
	480 / 500 V AC	40
	480 / 550 V AC	40
	600 V AC	40
Suitable for isolation		Yes
Endurance (cycles)	mechanical	5000 (w/o maint.); 10000 (with maint.)
	electrical	3000 (w/o maint.)
Weight (kg)	3P - Fixed	59
	3P - Drawout ⁽¹⁾	108
	4P - Fixed	76
	4P - Drawout ⁽¹⁾	137
Height (mm)	3P - Fixed	419
	3P - Drawout	465
	4P - Fixed	419
	4P - Drawout	465
Depth (mm)	3P - Fixed	354
	3P - Drawout	433
	4P - Fixed	354
	4P - Drawout	433
Width (mm)	3P - Fixed	408
	3P - Drawout	425
	4P - Fixed	538
	4P - Drawout	555
Temperature	operation	-25°C to +70°C
	storage	-25°C to +85°C
Maintenance		Yes (see specific guide)

⁽¹⁾ Weights for draw-out devices are to be intended with base

6.1 Main parts constituting the circuit breaker

Fixed version

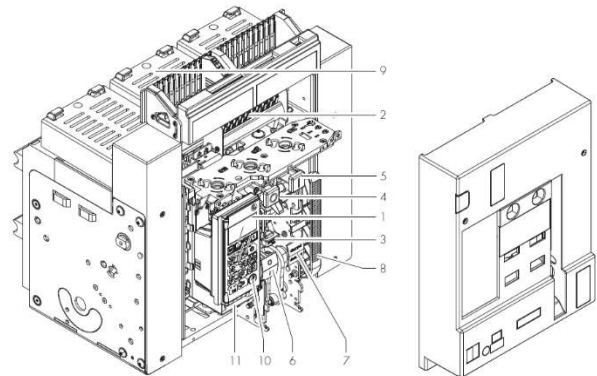

Draw-out version

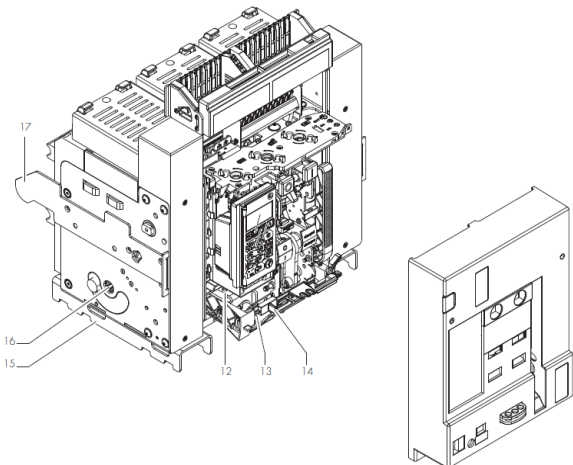

1. Protection Unit
2. Auxiliary Contacts
3. Reset button
4. OFF button
5. ON button
6. ON-OFF Indication
7. Spring Status Indication
8. Charging handle
9. Dejon cell
10. Mini USB cover
11. Battery cover
12. Draw-out mechanism
13. Draw-out bar insertion
14. Racking shutter
15. Support to place the breaker in draw-out cassette
16. Draw-out main shaft
17. Insertion guide

DMX-SP 4000 circuit breakers (PU MP2.10 and MP4.10) DMX-SP-I 4000 switch disconnectors

References:

6 702 60 / 61 / 62 / 63 / 65 / 66 / 67 / 68;

6 702 70 / 71 / 72 / 73 / 75 / 76 / 77 / 78;

6 696 80 / 81 / 82 / 88 / 84 / 85 / 86 / 87

Draw-out base

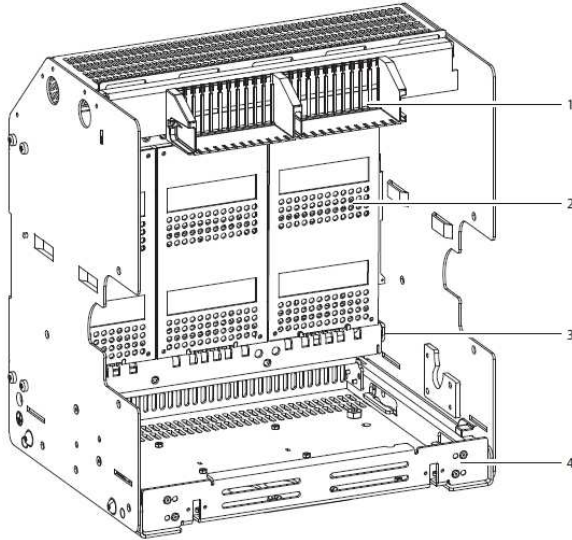

1. Aux terminal block
2. Safety shutter
3. Earth terminal
4. Removable cassette

6.2 Adjustment ranges

I_n (A)	Phases			
	I_r		I_{sd}	
	$0.2 \times I_n$	$1 \times I_n$	$1.5 \times I_r \text{ min}$	$10 \times I_r \text{ max}$
3200	640	3200	1920	32000
4000	800	4000	2400	40000

* For neutral adjustment, as explained in technical sheet, please consider the values ratios 0%, 50% and 100% on set currents.

6.3 Power losses per pole at I_n / I_e

Power Losses (W) DMX-SP 4000 and DMX-SP-I 4000			
Version	Fixed	Draw-out	
Rated current (A)	3200	109.6	215.0
	4000	172.2	336.0

Note: power loss in the table above are referred and measured as described in the standard IEC 60947-2 (Annex G) for circuit-breakers and IEC 60947-1 for switches. Values in the table are referred to a single phase.

6.4 Deratings

6.4.1 Temperature

Rated current and his adjustment must be considered relating to a rise or fall of ambient temperature and to a different version or installation conditions. The table below indicates the maximum long-time (LT) protection setting depending on the ambient temperature.

Temperature deratings for DMX-SP and DMX-SP-I fixed version - horizontal terminals

Temperature	DMX-SP 4000 and DMX-SP-I 4000 (fixed version)									
	up to 40°C		50°C		60°C		65°C		70°C	
	I_{max} (A)	I_r / I_n	I_{max} (A)	I_r / I_n	I_{max} (A)	I_r / I_n	I_{max} (A)	I_r / I_n	I_{max} (A)	I_r / I_n
Ratings	3200	1	3200	1	3104	0.97	2944	0.92	2880	0.90
	4000	1	3600	0.90	3400	0.85	3200	0.80	3000	0.75

Temperature deratings for DMX-SP and DMX-SP-I draw-out versions - horizontal terminals

Temperature	DMX-SP 4000 and DMX-SP-I 4000 (draw-out version)									
	up to 40°C		50°C		60°C		65°C		70°C	
	I_{max} (A)	I_r / I_n	I_{max} (A)	I_r / I_n	I_{max} (A)	I_r / I_n	I_{max} (A)	I_r / I_n	I_{max} (A)	I_r / I_n
Ratings	3200	1	3200	1	3104	0.97	2880	0.90	2720	0.85
	4000	1	3600	0.90	3320	0.83	3080	0.77	2800	0.70

6.4.2 Specific conditions use

Climatic conditions

according to IEC/EN 60947-1 Annex Q, Cat. F subject to temperature, humidity, vibration, shock and salt mist.

Electromagnetic disturbances (EMC)

according to IEC/EN 60947-2 Annex F.

6.4.3 Altitude

Altitude derating for DMX-SP and DMX-SP-I

Altitude (m)	< 2000	3000	4000	5000
Rated current (A)	I_n	$0.98 \times I_n$	$0.94 \times I_n$	$0.9 \times I_n$
Rated voltage U_e (V)	690	600	500	440
Rated insulation voltage U_i (V)	1000	900	750	600
Dielectric withstand (V)	3500	3200	2500	2000

DMX-SP 4000 circuit breakers (PU MP2.10 and MP4.10) DMX-SP-I 4000 switch disconnectors

References:

6 702 60 / 61 / 62 / 63 / 65 / 66 / 67 / 68;

6 702 70 / 71 / 72 / 73 / 75 / 76 / 77 / 78;

6 696 80 / 81 / 82 / 88 / 84 / 85 / 86 / 87

6.5 Electronic protection unit

All DMX³ 4000 can be equipped by an MP2.10 or MP4.10 electronic protection unit which main characteristics are:

- Integrated LED matrix screen to show electrical values and settings (MP2.10) or Integrated LCD screen for displaying electrical values, settings and log (MP4.10)
- Adjustment via rotating encoder
- Adjustment of I_r , t_r , I_{sd} , t_{sd} , I_i , I_g and t_g
- Possibility to enable/disable protections
- Measure and display instantaneous, maximum and average values of different electrical values and protection conditions, fault signaling and log (for versions with measure)
- Equipped with batteries for powering in case of mains fault or when the breaker is open or not connected (MP4.10)

All protection units have onboard a mini USB type "B" socket for maintenance purposes or PCS software connection to PC

6.5.1 Protection unit types

Protection unit are available in in MP2.10 and MP4.10 type as following

Type	Features		Reference
	display	with measure	
MP2.10	LED matrix	NO	0 283 04
		YES	0 283 06 (*)
MP4.10	LCD screen	NO	0 283 06
		YES	0 283 07 (*)

(*) For the correct working of metering function, it's necessary to connect a CX³ EMS power supply module ref. 4 149 45

Protective functions

I_r : Long time delay protection against overloads

From 0.2 to 1 x I_n with steps of 1A

Protection: ON/OFF

t_r : Long delay protection operation time

From 40ms to 30 s (@6Ir) with steps of 40ms

Thermal memory: ON/OFF

I_{sd} : Short time delay protection against short-circuits

From 1.5 to 10 x I_r with steps of 1A

Protection: ON/OFF

t_{sd} : Short time delay protection operation time

From 40ms to 1 s with steps of 40ms

(both $t=k$, independent time delay, and $I^2t=k$, inverse short time delay)

I_i : Instantaneous protection against very high short-circuits

From 2 to 15 x I_n or I_{cw} with steps of 1A

Protection: ON/OFF

I_g : Earth fault current

From 0.2 to 1 x I_n with steps of 1A

Protection: ON/OFF

t_g : Time delay on earth fault tripping

From 80ms to 1s with steps of 40ms

(both $t=k$, independent time delay, and $I^2t=k$, inverse short time delay)

IN : Neutral protection

OFF - 50% - 100% - 200%

6.5.2 Configuration

Protection units MP2.10 and MP4.10 are fully configurable and can be configured in complete freedom.

They can be used to adapt settings as closely as possible to the requirements of the specific installation, either by enabling/disabling the different protection devices (currents and tripping times), or by altering the different trip thresholds.

The tripping curve is thus fully customised to suit the real-life conditions of each project.

Protection units with integrated measurement function can also be used to display voltages, active and reactive powers, frequency, power factor, and also energy, in addition to monitoring currents.

Alarms can be programmed on a number of these parameters: max. voltage, min. voltage, voltage unbalance, max. and min. frequency, etc

6.6 Common accessories for protection units

- Bluetooth communication key ref. 0 283 10
USB key for Bluetooth communication with DMX³ protection unit, needed to monitor and manage (test and report) the DMX³ protection units through EnerUp + Project App USB connection port on front of protection unit.

- Power supply module ref. 4 149 45
500 mA 12V DC stabilized power supply module for CX³ energy management system – 1 DIN module.
To use for correct use of protection units with measure function (ref. 0 283 01 and 0 283 03)

- Communication interface ref. 4 149 40
RS485 / CX3 energy management system conversion
Consumption: 0.344 W - 28.7 mA (12 V DC) – 1 DIN module

- External neutral for DMX³ 1600 ref. 0 281 98
Optional accessories, to be ordered when ordering electronic protection unit and DMX³ air circuit breakers for factory assembly

DMX-SP 4000 circuit breakers (PU MP2.10 and MP4.10) DMX-SP-I 4000 switch disconnectors

References:

6 702 60 / 61 / 62 / 63 / 65 / 66 / 67 / 68;
6 702 70 / 71 / 72 / 73 / 75 / 76 / 77 / 78;
6 696 80 / 81 / 82 / 88 / 84 / 85 / 86 / 87

7. CONFORMITY

DMX-SP range of product concerning circuit-breakers and switch-disconnectors exceed compliance with the IEC/EN standard 60947-2 and 60947-3 respectively. Certification available by IECEE CB-scheme or LOVAG Compliance scheme.

Marks as CCC (China), EAC (Eurasian Federation) or different local certification are available.

DMX-SP are in conformity with the Lloyds Shipping Register, RINA and Bureau Veritas Marine.

DMX-SP respect the European Directives REACH, RoHS, RAEE and Product Environment Product (PEP Ecopassport) are available.

7.1 MARKING

Product is provided with labelling in full conformity to the referred standard and directives requirements by laser or sticker labels as:

Product laser label on front

- Manufacturer responsible
- Denomination, type product, code
- Standard conformity
- Standard characteristics declared
- coloured identification of I_{cu} at 415'

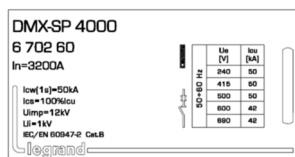

Product sticker label on side

- Manufacturer responsible
- Denomination and type product
- Standard conformity
- Mark/Licence (if any)
- Directive requirements
- bar code identification product
- Manufacturing Country



Mark sticker label on side

- Product code
- Mark/Licence (if any)
- Country deviation, if any

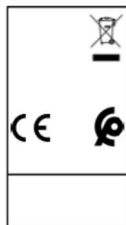

Packaging sticker label

- Manufacturer responsible
- Denomination and type product
- Standard conformity
- Mark/Licence (if any)
- Directive requirements
- bar code identification product



8. EQUIPMENTS AND ACCESSORIES

8.1 Control auxiliaries

- shunt trip: when energised the circuit breaker will be tripped
 - 24 V AC and DC ref. 0 288 48
 - 48 V AC and DC ref. 0 288 49
 - 110 ÷ 130 V AC and DC ref. 0 288 50
 - 220 ÷ 250 V AC and DC ref. 0 288 51
 - 415 ÷ 480 V AC ref. 0 288 52

Rated operating voltage (U _c)	AC: 24V;48V;110V ÷ 130V;220V ÷ 250V;415V/440V/480V DC: 24V; 48V; 110V ÷ 130V; 220V ÷ 250V
Voltage range (%U _c)	70 ÷ 110
Pick-up consumption (W / VA)	500 / 500
Pick-up time (ms)	180
Hold consumption (W / VA)	5 / 5
Minimum opening time (ms)	30
Insulation voltage (kV)	2.5

- undervoltage releases: when the coil is de-energised, the circuit breaker will be tripped
 - 24 V AC and DC ref. 0 288 55
 - 48 V AC and DC ref. 0 288 56
 - 110 ÷ 130 V AC and DC ref. 0 288 57
 - 220 ÷ 250 V AC and DC ref. 0 288 58
 - 415 ÷ 440 V AC ref. 0 288 59

Rated operating voltage (U _c)	AC: 24V;48V;110V ÷ 130V;220V ÷ 250V;415V/440V/480V DC: 24V; 48V; 110V ÷ 130V; 220V ÷ 250V
Voltage range (%U _c)	85 ÷ 110
Pick-up consumption (W / VA)	500 / 500
Pick-up time (ms)	180
Hold consumption (W / VA)	5 / 5
Minimum opening time (ms)	60
Insulation voltage (kV)	2.5

- Modules for delayed tripping, to be used with undervoltage releases (in common with DMX-SP 2500)
 - 110 V AC and DC ref. 0 288 62
 - 230 V AC and DC ref. 0 288 63

Rated operating voltage (U _c)	AC: 110V / 230V DC: 110V / 230V
Voltage range (%U _c)	85 ÷ 110
Pick-up consumption (W / VA)	16.5 (@110V) / 34.5 (@230V)
Time delay (s)	1 ⁽¹⁾
Hold consumption (W / VA)	5 (@110V) / 10 (@230V)
Opening threshold	0.35 ÷ 0.7 U _n
Closing threshold	0.85 U _n
Operating temperature (°C)	-10 ÷ +55

⁽¹⁾ It is possible to connect up to 3 modules - 1s of delay for each module installed

- Motor operators
 - Connect to a release coil (UVR or trip on energising) and a closing coil
 - 24 V AC and DC ref. 0 288 34
 - 48 V AC and DC ref. 0 288 35
 - 110 ÷ 130 V AC and DC ref. 0 288 36
 - 220 ÷ 250 V AC and DC ref. 0 288 37
 - 415 ÷ 440 V AC ref. 0 288 38
 - 480 V AC and DC ref. 0 288 40

Rated operating voltage (U _c)	AC: 24V;48V;110V ÷ 130V;220V;250V;415V ÷ 440V;480V DC: 24V; 48V; 110V ÷ 130V; 220V ÷ 250V
Voltage range (%U _c)	85 ÷ 110
Maximum Power consumption (W / VA)	180/180
Maximum peak current for 80ms	(2 ÷ 3) × I _n
Charging time (s)	5
Operating frequency (n° / min)	2

DMX-SP 4000 circuit breakers

(PU MP2.10 and MP4.10)

DMX-SP-I 4000 switch disconnectors

References:

6 702 60 / 61 / 62 / 63 / 65 / 66 / 67 / 68;

6 702 70 / 71 / 72 / 73 / 75 / 76 / 77 / 78;

6 696 80 / 81 / 82 / 88 / 84 / 85 / 86 / 87

• Closing coils

To enable remote closing of the circuit breaker if the closing spring is charged

24 V AC and DC	ref. 0 288 41
48 V AC and DC	ref. 0 288 42
110 ÷ 130 V AC and DC	ref. 0 288 43
220 ÷ 250 V AC and DC	ref. 0 288 44
415 ÷ 480 V AC	ref. 0 288 45

• Door locking

Prevents opening of the door with the circuit breaker closed

Left-hand and right-hand side mounting ref. 0 288 20

• Padlocks in "open" position

Padlocking system for ACB (padlock not supplied) ref. 0 288 21

Padlocking system for shutters (padlock not supplied) ref. 0 288 26

8.4 Accessories

• Mechanical operations counter: to count total number of operation cycles of device ref. 0 288 23

• Rating mis-insertion device: to prevent the insertion of a draw-out circuit breaker into an incompatible base ref. 0 288 25

• Lifting plate ref. 0 288 79

8.5 Fixing devices for DMX-SP and DMX-SP-I 4000

Specific instruction sheets are provided to integrate DMX-SP and DMX-SP-I 4000 into XL³ enclosures ranges (fixing plates, metal faceplates for circuit breakers and cable sleeves, etc...).

8.6 Draw-out base

• Bases for draw-out device

For DMX-SP / DMX-SP-I 4000 frame 3P ref. 6 696 12

For DMX-SP / DMX-SP-I 4000 frame 4P ref. 6 696 13

8.7 Equipment for interlocking

The mechanical interlock is set up using cables and can interlock 2 or 3 devices (all DMX-SP 4000) in a vertical or horizontal configuration. The interlock unit is mounted on the right-hand side of the device. Interlock cables to be ordered separately.

• Interlock for DMX-SP 4000 ref. 0 288 65

8.8 Interlock cables

(in common with DMX-SP 2500)

- 1000 mm ref. 0 289 17
- 1500 mm ref. 0 289 18
- 2600 mm ref. 0 289 20
- 3000 mm ref. 0 289 21
- 3600 mm ref. 0 289 22
- 4000 mm ref. 0 289 23
- 4600 mm ref. 0 289 24
- 5600 mm ref. 0 289 25

Rated operating voltage (U_c)	AC: 24V;48V;110V ÷ 130V;220V ÷ 250V;415V/440V/480V DC: 24V; 48V; 110V ÷ 130V; 220V ÷ 250V
Voltage range (%V_n)	85 ÷ 110
Pick-up consumption (W / VA)	500 / 500
Pick-up time (ms)	180
Hold consumption (W / VA)	5 / 5
Maximum closing time (ms)	50
Insulation voltage (kV)	2.5

8.2 Signalling auxiliaries

• Signalling contact for draw-out version

Inserted / test / draw-out signalling contact

3 changeover contacts per position ref. 0 288 13

Rated operating voltage (U_c)	DC	250V 0.3A 125V 0.6A
	AC	250V 16A 125V 16A

• Contact "ready to close" with charged springs ref. 0 288 14

Rated operating voltage (U_c)	AC	250V 16A 125V 16A
--	-----------	----------------------

• Additional signalling contact ref. 0 288 15

Rated operating voltage (U_c)	DC	250V 0.3A 125V 0.6A
	AC	250V 16A 125V 16A

• Signalling contact for auxiliaries (ST, CC and UVR) ref. 0 288 16

Rated operating voltage (U_c)	DC	250V 0.3A 125V 0.6A
	AC	250V 16A 125V 16A

• Trip contact (CRT) (factory assembled) ref. 6 696 16

Rated operating voltage (U_c)	AC	250V 6A
--	-----------	---------

8.3 Locking

Universal key locks

To be used in combination with key locking support ref. 0 281 91

- Key barrel and flat key with random mapping ref. 4 238 80
- Key barrel and flat key with fixed mapping EL43525 ref. 4 238 81
- Key barrel and flat key with fixed mapping EL 43363 ref. 4 238 82
- Key barrel and star key with random mapping ref. 4 238 83
- Key locking support in "open" position ref. 0 288 28
To be equipped with universal keylocks ref. 4 238 80/81/82/83
- Key locking support in "draw-out" position ref. 0 281 94
To be equipped with universal keylocks ref. 4 238 80/81/82/83

DMX-SP 4000 circuit breakers (PU MP2.10 and MP4.10) DMX-SP-I 4000 switch disconnectors

References:

6 702 60 / 61 / 62 / 63 / 65 / 66 / 67 / 68;

6 702 70 / 71 / 72 / 73 / 75 / 76 / 77 / 78;

6 696 80 / 81 / 82 / 88 / 84 / 85 / 86 / 87

Choice of interlock cable

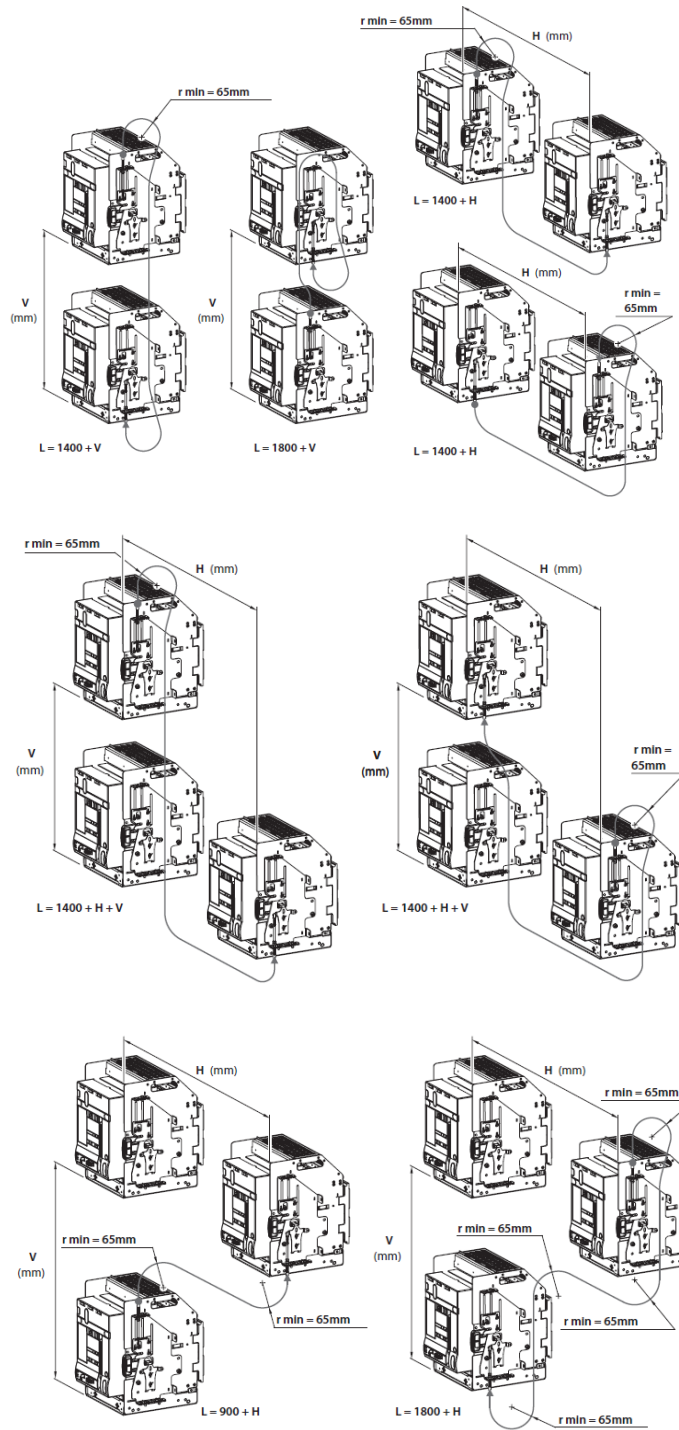

8.9 Rear terminals

- For fixed version
 - For flat connections with bars, 3P ref. 6 696 14
 - For flat connections with bars, 4P ref. 6 696 15
 - For vertical connections with bars, 3P ref. 0 288 94
 - For vertical connections with bars, 4P ref. 0 288 95

Note 1: refs. 6 696 14/15 to be fixed onto horizontal rear terminals of the circuit breaker

Note 2: refs. 0 288 94/95 to be used to transform a flat connection into a vertical one. To be fixed onto refs. 6 696 14/15 according to the number of poles.

- For draw-out version
 - For vertical or horizontal connections with bars, 3P ref. 0 288 94
 - For vertical or horizontal connections with bars, 4P ref. 0 288 95

Note: to be fixed directly onto plate rear terminals of the circuit breaker

8.10 Insulating shields

- Fixed version 3P ref. 0 288 98
- Fixed version 4P ref. 0 288 99
- Draw-out version 3P ref. 0 288 18
- Draw-out version 4P ref. 0 288 19

DMX-SP 4000 circuit breakers (PU MP2.10 and MP4.10) DMX-SP-I 4000 switch disconnectors

References:

6 702 60 / 61 / 62 / 63 / 65 / 66 / 67 / 68;

6 702 70 / 71 / 72 / 73 / 75 / 76 / 77 / 78;

6 696 80 / 81 / 82 / 88 / 84 / 85 / 86 / 87

9. CURVES

9.1 TRIPPING CURVE FOR DMX-SP 4000 MPx.10 protection units: L – T protection detail

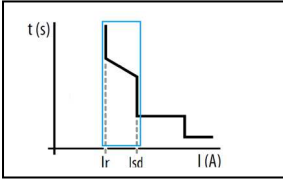

Update: 14/10/2022

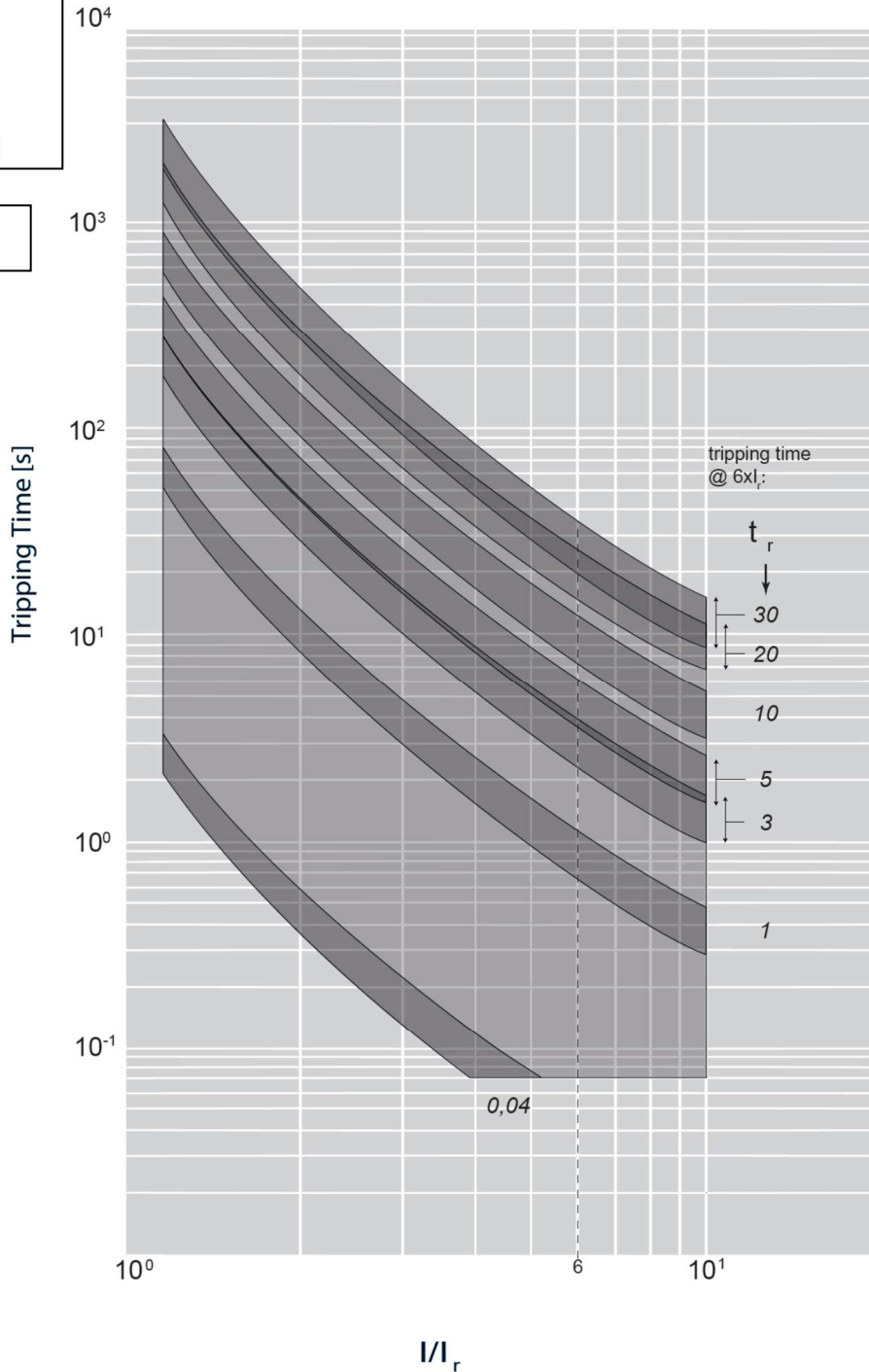

Value	Description
I	current
I_r	long time setting current
t_r	long time delay

DMX-SP 4000 circuit breakers (PU MP2.10 and MP4.10) DMX-SP-I 4000 switch disconnectors

References:

6 702 60 / 61 / 62 / 63 / 65 / 66 / 67 / 68;

6 702 70 / 71 / 72 / 73 / 75 / 76 / 77 / 78;

6 696 80 / 81 / 82 / 88 / 84 / 85 / 86 / 87

9.2 TRIPPING CURVE FOR DMX-SP 4000 MPx.10 protection units: short time trip protection detail

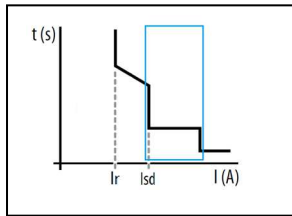

Update: 17/11/2022

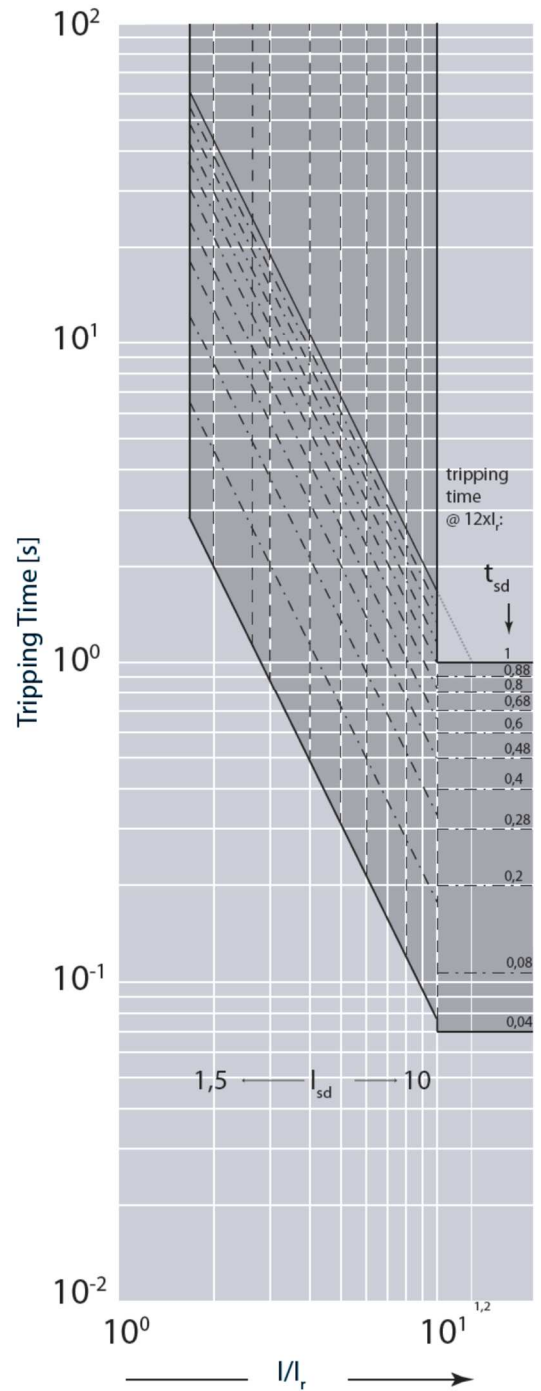
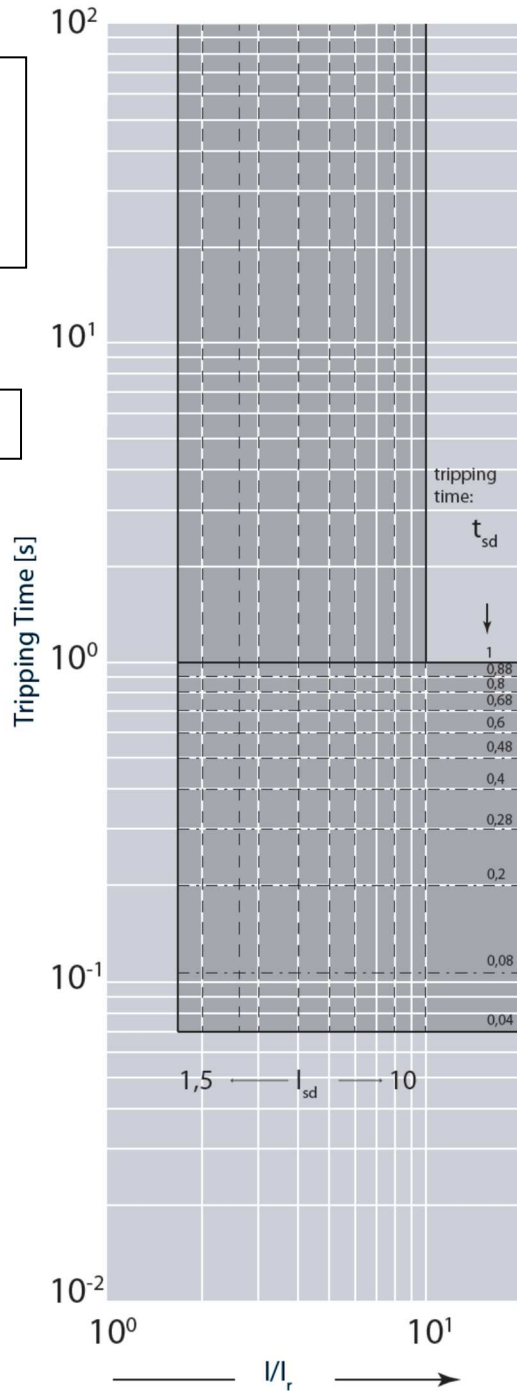

Value	Description
I	current
I_{sd}	short time setting current
t_{sd}	short time delay

DMX-SP 4000 circuit breakers (PU MP2.10 and MP4.10) DMX-SP-I 4000 switch disconnectors

References:
6 702 60 / 61 / 62 / 63 / 65 / 66 / 67 / 68;
6 702 70 / 71 / 72 / 73 / 75 / 76 / 77 / 78;
6 696 80 / 81 / 82 / 88 / 84 / 85 / 86 / 87

9.3 TRIPPING CURVE FOR DMX-SP 4000 MPx.10 protection units: instantaneous trip protection detail

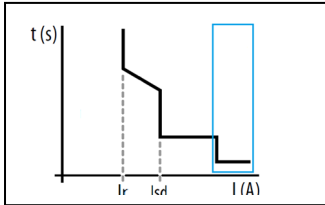

Update: 17/11/2022

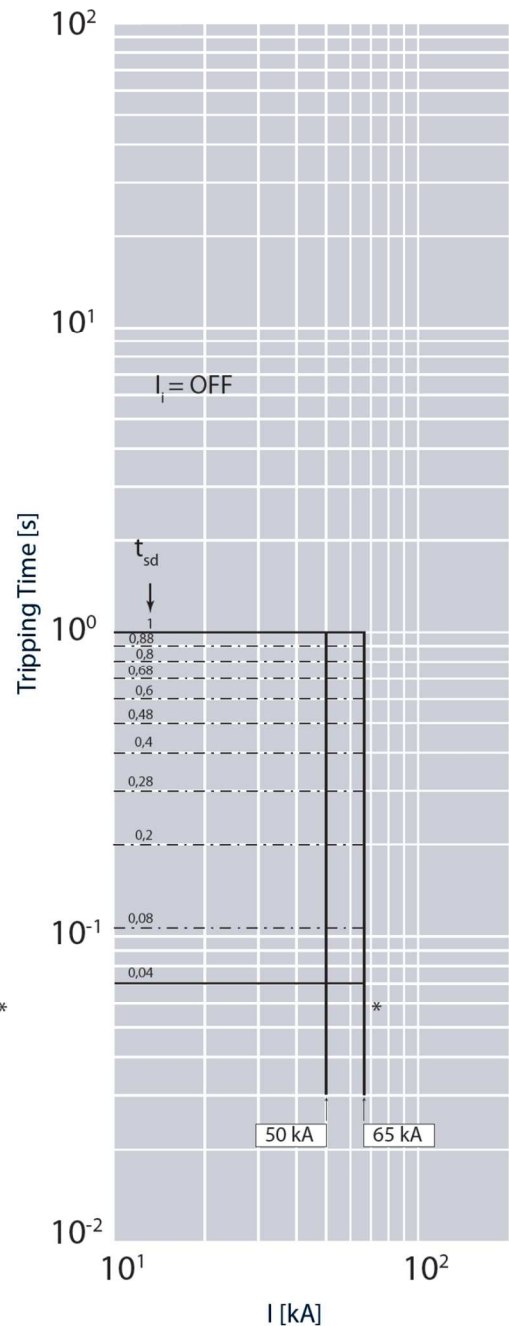
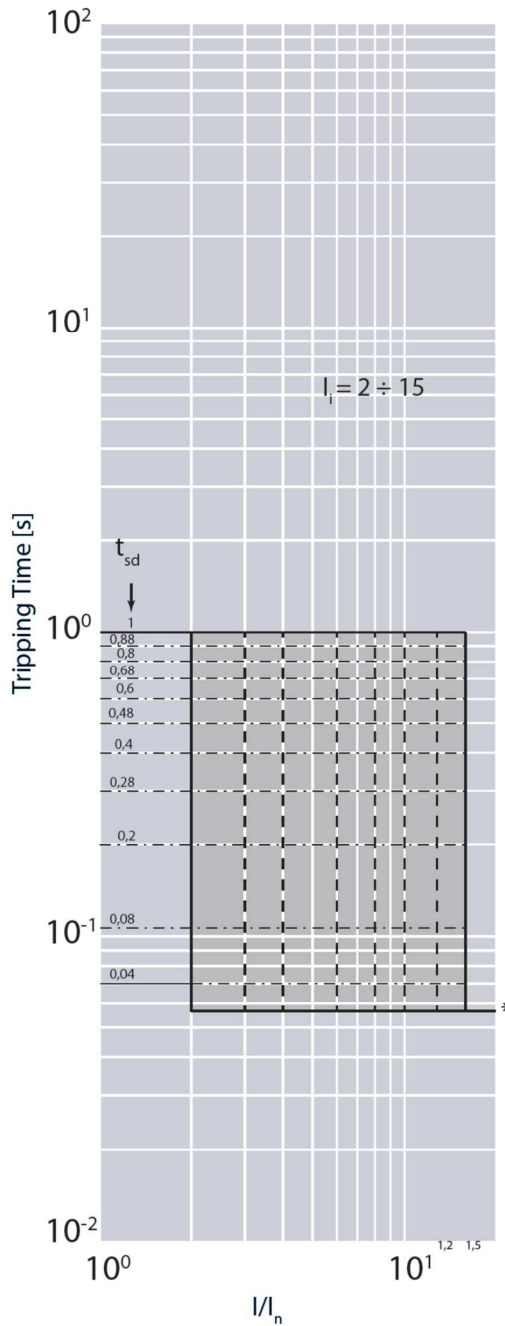

* Fixed Instantaneous override – I_{ov} →

Value	Description
I	current
I_n	rated current
t_{sd}	short time delay
I_i	Instantaneous release
I_{cw}	Rated short time withstand current

I_{cu}	Values for I_{ov}
50kA	50kA
65kA	65kA

DMX-SP 4000 circuit breakers (PU MP2.10 and MP4.10) DMX-SP-I 4000 switch disconnectors

References:

6 702 60 / 61 / 62 / 63 / 65 / 66 / 67 / 68;

6 702 70 / 71 / 72 / 73 / 75 / 76 / 77 / 78;

6 696 80 / 81 / 82 / 88 / 84 / 85 / 86 / 87

9.4 Ground fault curve for DMX-SP 4000 MPx.10 protection units

Update: 17/11/2022

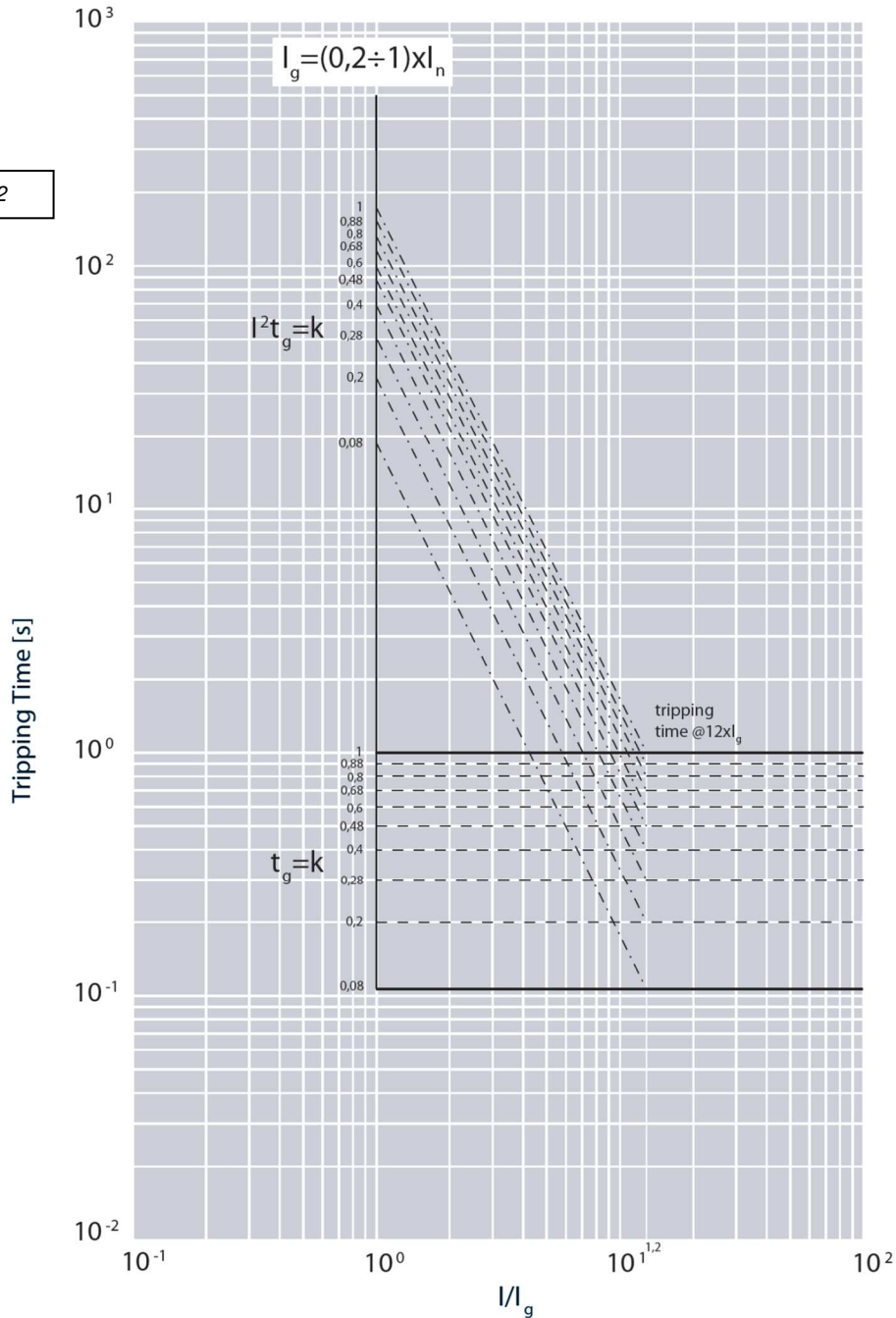

Value	Description
I	current
I_n	rated current
I_g	Ground fault current
t_{sd}	short time delay
$t_{sd} = k$	Constant tripping time setting
$I^2 t_{sd} = k$	Constant pass-through energy setting

**DMX-SP 4000 circuit breakers
(PU MP2.10 and MP4.10)
DMX-SP-I 4000 switch disconnectors**

References:

6 702 60 / 61 / 62 / 63 / 65 / 66 / 67 / 68;

6 702 70 / 71 / 72 / 73 / 75 / 76 / 77 / 78;

6 696 80 / 81 / 82 / 88 / 84 / 85 / 86 / 87

9.5 PASS-THROUGH SPECIFIC ENERGY CURVE (at 415V)

Update: 14/07/2021

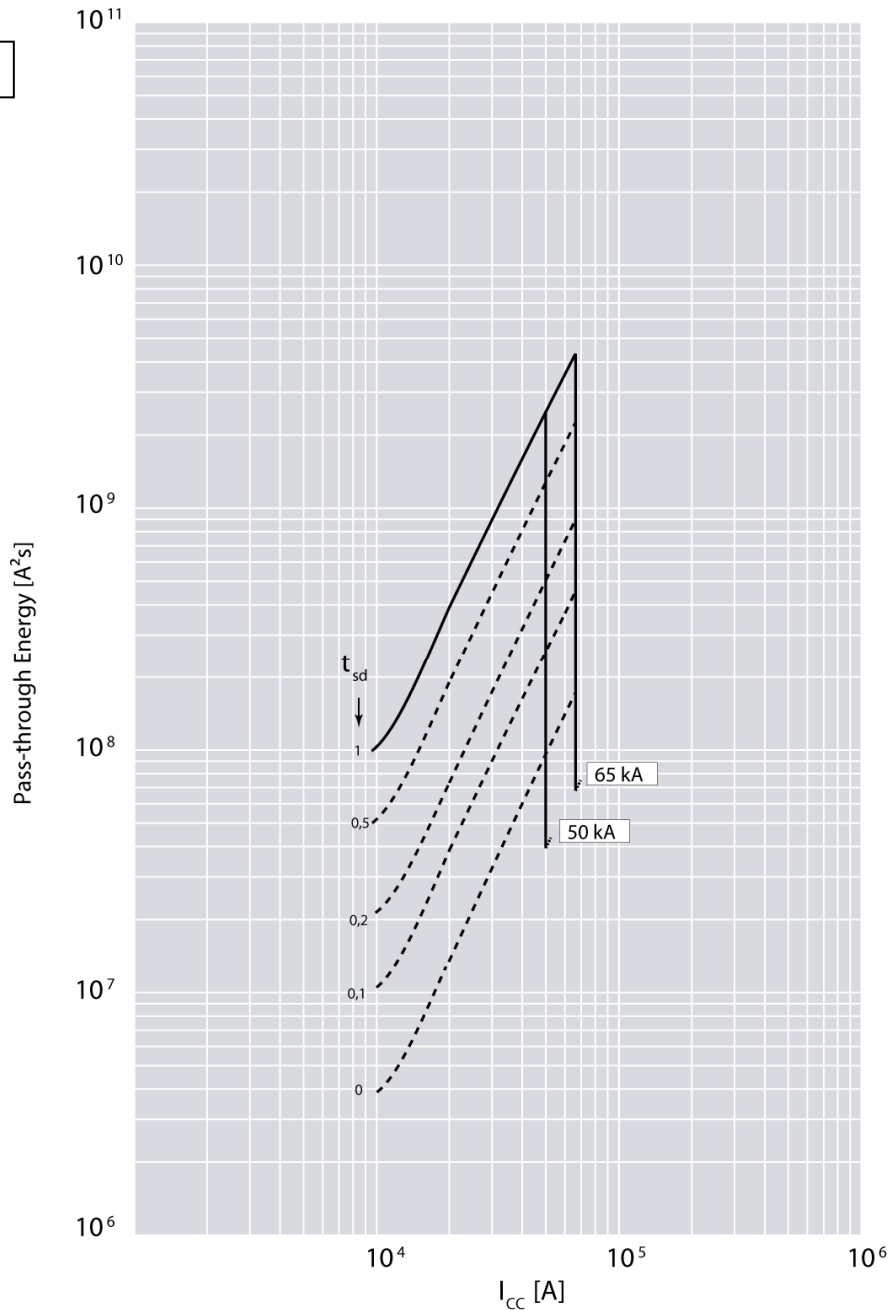

Value	Description
I	current
I _n	rated current
I _g	Ground fault current
t _{sd}	short time delay
t _{sd} = k	Constant tripping time setting
I ² t _{sd} = k	Constant pass-through energy setting