

Plexo™ with Netatmo

Weatherproof connected wireless batteryless roller shutter control

Cat. No(s): 0 698 73L/83L

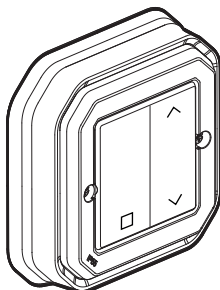

1. USE

Zone or centralised wireless batteryless control for wired roller shutter switches.

Only for controlling "...with Netatmo" connected wired roller shutter switches and micromodules.

With its IP55 weatherproofing, this product can be used to control roller shutters in places where damp and dust can be an issue.

Fixes directly on a wall or on a piece of furniture (movable).

Can control up to 20 wired roller shutter switches.

2. RANGE

Weatherproof connected wireless batteryless roller shutter control.

Supplied complete with plate.

Equipped with a button (concealed) used to configure the product.

Grey	Anthracite
0 698 73L	0 698 83L

3. DIMENSIONS (mm)

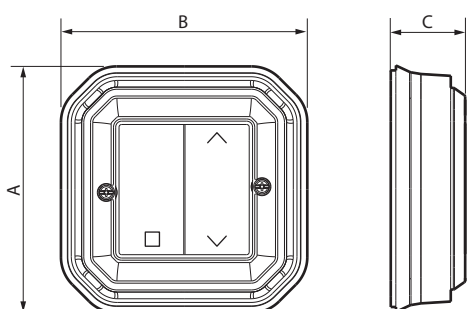

A	B	C
85.5	85.5	26

4. DESCRIPTION

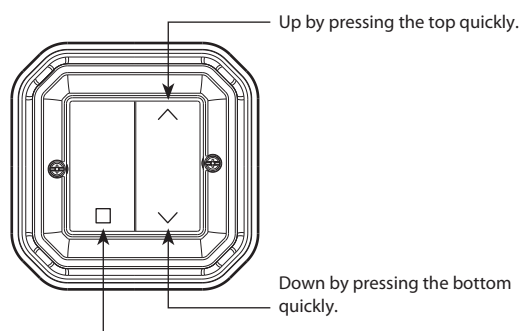

STOP by pressing the bottom quickly.

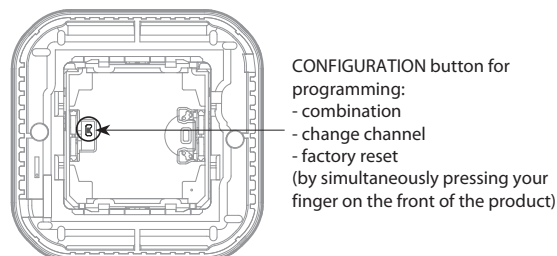

NB: For information about programming this product, please see user manual 0 698 73L.

5. TECHNICAL CHARACTERISTICS

■ 5.1 Mechanical characteristics

Protection against impacts: IK 08

Protection against solid bodies and/or liquids: IP 55

■ 5.2 Material characteristics

Base: ABS

Plate: ABS

Cassette holder and cassette: Fibreglass-reinforced (10%) PC

Cover plate: PP + SEBS

Rocker plate: Painted ABS

Transparent membrane: SEBS

Halogen-free

UV resistant

Self-extinguishing: 650°C/30 s

Plexo™ with Netatmo

Weatherproof connected wireless batteryless roller shutter control

5. TECHNICAL CHARACTERISTICS *(continued)*

■ 5.3 Electrical characteristics

Wireless batteryless self-contained switch.

Zigbee radio technology: frequency 2.4 GHz to 2.4835 GHz

Radio performance: 150 m min. range in unobstructed space, point to point

Power level: < 20 mW

■ 5.4 Climate characteristics

Usage temperature: +5°C to +45°C

Storage temperature: 0°C to +45°C

6. CARE

Clean the surface with a cloth.

Do not use acetone, tar-removing cleaning agents or trichloroethylene.

Resistant to the following products: Hexane, methylated spirit, soapy water, diluted ammonia, bleach diluted to 10%, window-cleaning products, pre-impregnated wipes.

Caution: Always test before using other special cleaning products.

The product must not be painted.

7. STANDARDS AND APPROVALS

Certified Zigbee technology, Green Power function.

IEEE 802.15.4 (LR-WPAN).

LEGRAND declares that the radio-electric equipment type (0 698 73L/ 83L) complies with directive 2014/53/EU.

Compliant with installation and manufacturing standards.

See e-catalogue.