



Home + Control
LEGRAND

The Ecometer can be used offline without an internet connection (directly on the product screen), or can be added to a “with Netatmo” connected installation and managed via the Home + Control app



4 120 32



4 120 33



4 120 08

CONTENTS

Page

1. Description - Use	1
2. Range	1
3. Dimensions.....	2
4. Positioning - Connection.....	2
5. General characteristics	4
6. Configuration.....	5
7. Navigation screens.....	6
8. Compliance.....	8

1. DESCRIPTION - USE

Use:

Used to measure and display total or partial electricity consumption in real time across five zones: heating, air conditioning/cooling, domestic hot water (DHW), power socket circuit and/or other circuits as required (lighting or electric vehicle sockets for example), in euro, kWh or m³. It can also be used to monitor the consumption of water (hot and cold) and gas meters.

Product conforming to the requirements imposed by articles 27 and 28 of Environmental Regulation 2020.

Must be used with measurement coils Cat.No 4 120 08 (5 maximum - not supplied for Cat.No 4 120 32 and 3 supplied for Cat.No 4 120 33).

The Connected Ecometer “with Netatmo” is a stand-alone device which can be used in offline mode (without an internet connection) or integrated into connected installation and managed using the Home + Control application.

When installed in stand-alone : there is no need to buy an additional gateway (No “With Netatmo” starter Pack required).

When installed as long as other “with Netatmo” modules, please note that the Connected Ecometer will then automatically integrate a separated “house installation” in your H+C app.

This operation therefore will disconnect it from the rest of the modules and future functions updates related to the application.

The Connected Ecometer offers the following functions:

- Measuring the total instantaneous power for the installation
- Measuring the total electricity consumption for the building. This information can come from the CIS (Customer Information System) if it is connected and working or, if not, a measurement coil connected to the “Total (5)” input
- Measuring partial consumption of 4 to 5 specific customised lines^(*): heating, lighting, sockets, electric vehicle socket, etc. (* up to 5 lines if the CIS is connected and working)
- Measuring consumption of hot water, cold water and gas via pulse meters (not supplied)
- Taking Peak/Off-Peak times into account via a direct CIS (Customer Information System) link or by programming time slots offline (directly on the product screen) or in the Home + Control app
- Viewing, in real time, the building’s overall electricity consumption (electricity, water and gas)
- Daily, monthly and annual log of consumption, which can be viewed offline (directly on the product screen) and remotely via the Home + Control app.

Comprises:

- 1 Ethernet IP RJ 45 output and Wi-Fi connectivity for remote access and product updates via the Home + Control app
- 5 inputs for quick-connect measurement coils (Cat.No 4 120 08) including 1 dedicated to total consumption (if the CIS is not connected and working) for measuring the electrical circuits
- 1 CIS input for electronic meter or Linky allowing automatic management of tariff periods and measurement of total electrical consumption
- 3 wired pulse inputs for measuring gas, cold water and hot water.

2. RANGE

Range Cat.No:

- 4 120 32: Connected Ecometer
- 4 120 33: Connected Ecometer kit:
 - 1 Ecometer
 - 3 Measurement coils
- 4 120 08: Measurement coil (Imax 80 A AC)

Dimensions:

Ecometer: 5 modules 17.8 mm wide

Nominal voltage:

Un: 100/240 V~ (Phase - Neutral). Neutral on left

Nominal current:

Maximum current Imax = 80 A (via external measurement coil)

Nominal frequencies:

- 50 Hz (permitted variations: 45/55 Hz)
- 60 Hz (permitted variations: 55/65 Hz)

Configuration and use:

Can be used with the “Home + Control” app, a free download from Google Play or the App Store.



3. DIMENSIONS

3.1 Ecometer (5 modules)

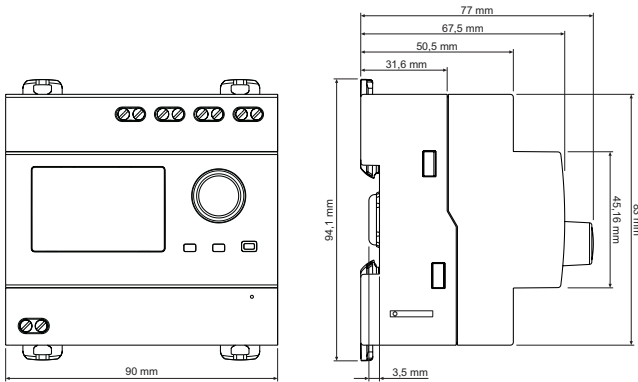

3.2 Ecometer screen

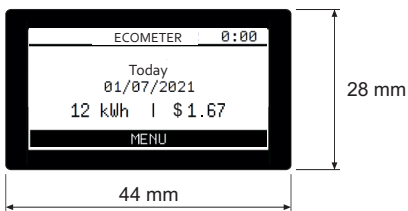

3.3 Measurement coil

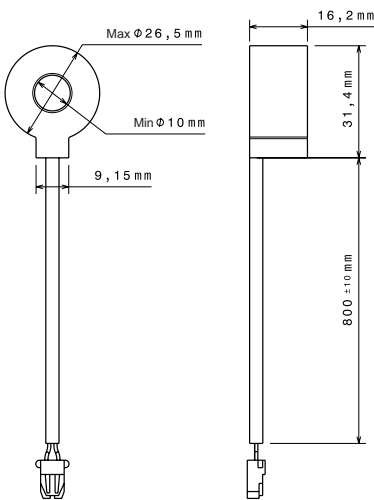

4. CONNECTION - INSTALLATION

4.1 Fixing

On EN/IEC 60715 symmetrical rail or DIN 35 rail
Tool required: 5.5 mm flat screwdriver (6 mm max.)

4.2 Operating positions

Vertical Horizontal Upside down On the side



4.3 Connection terminals

Cat.Nos. 4 122 30/32/33

• Pulse input

Terminal depth: 8 mm
Recommended stripping length: 8 mm
Slotted screw head: Ø3.5 mm
Recommended tightening torque: 0.4/0.5 Nm
Tool required: 3.5 mm flat screwdriver

• Power supply terminal (1P+N)

Terminal depth: 8 mm
Recommended stripping length: 8 mm
Slotted screw head: Ø3.5 mm
Recommended tightening torque: 1 Nm
Tool required: 3.5 mm flat screwdriver

4.4 Terminal capacity:

Cat.Nos. 4 122 30/32/33

	Terminals	Without ferrule	With ferrule
Rigid cable	Pulse input	1 x 2.5 mm ² 2 x 1 mm ²	
	Power supply	1 x 2.5 mm ² 2 x 1.5 mm ²	
Flexible cable	Pulse input	1 x 2.5 mm ² 2 x 1 mm ²	1 x 2.5 mm ² 2 x 1 mm ²
	Power supply	1 x 2.5 mm ² 2 x 1.5 mm ²	1 x 2.5 mm ² 2 x 1.5 mm ²

4.5 Measurement coil capacity

Cat.No 4 120 08

Cable cross section	1.5 mm ²	2.5 mm ²	6 mm ²	10 to 25 mm ²
Number of cables	10	7	4	1

4.6 Controlling the Ecometer

- Navigation via thumbwheel

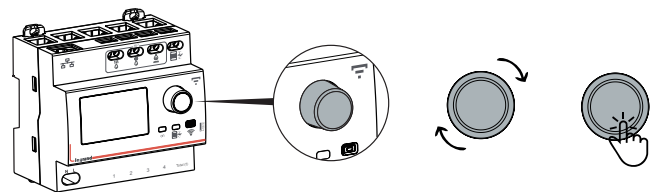

- Navigation using a smartphone with the Home+Control smartphone app



■ 4.7 Wiring diagram

- A 100/240 V~ power supply is mandatory between phase and neutral.
- The device must be protected by a circuit breaker or a 2 A fuse.

Installation without CIS (Customer Information System) connected

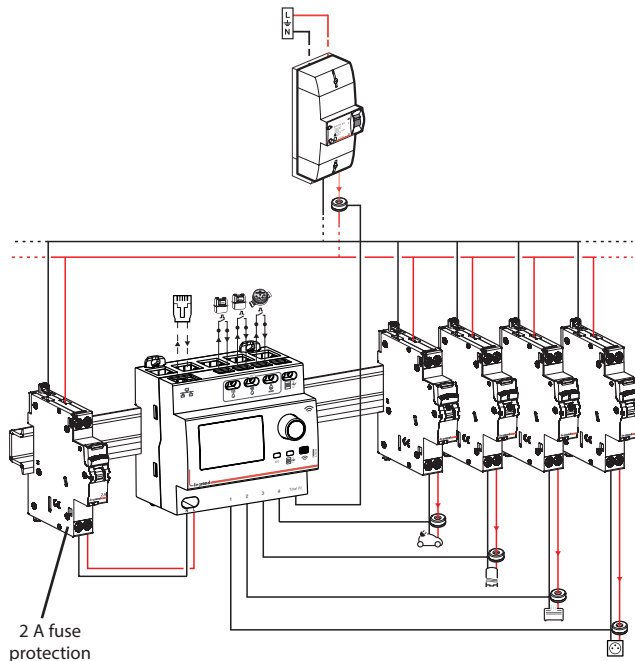

Installation with CIS (Customer Information System) connected

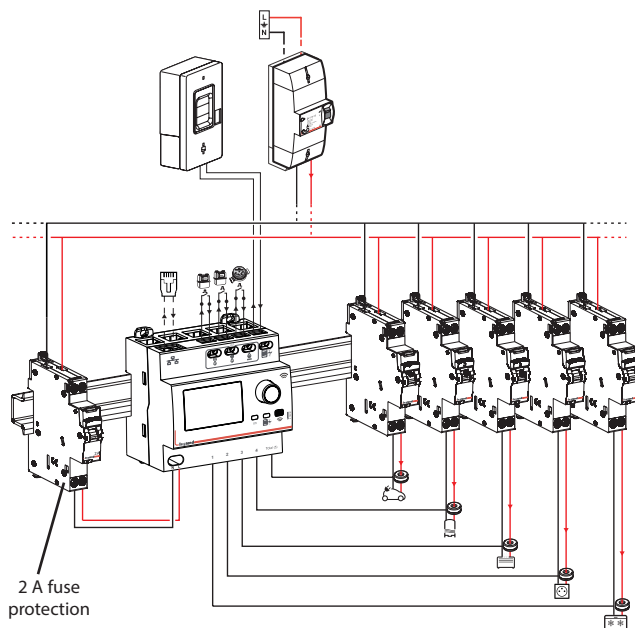

- The measurement coils are connected to the Ecometer via a fast-on connector. No tool is required.

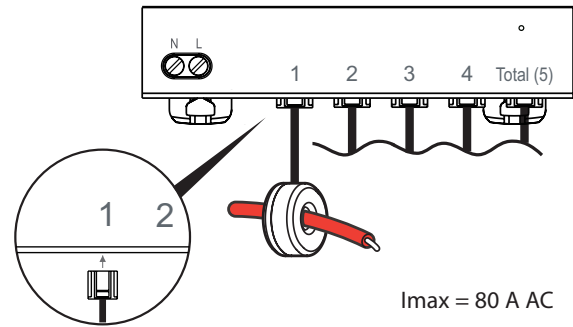

An arrow on the coil indicates the correct current direction.



■ 4.8 Integration in a connected installation

- There is no need to install a “with Netatmo” starter pack to use the connected Ecometer via the Home + Control app.
- However, the Ecometer is not a gateway. If you wish to add other “with Netatmo” connected products, you will need to install a starter pack that includes a gateway power module or gateway power outlet.

Important information about TOTAL measurement:

- 1 Connected Ecometer maximum per installation
- Several measurement coils can be placed on the incoming line of the main power supply (total consumption). Eg: the Ecometer or Meter coil
- If several connected appliances measure total consumption, the total consumption data item displayed on the app is, in order of priority, the one from the:
 - The Connected Ecometer
 - The Connected Energy Controller
 - The Electricity Meter
- The Connected Ecometer does not take account of photovoltaic power

1/ To integrate a Connected Ecometer in an electrical installation, you need:

- A Connected Ecometer

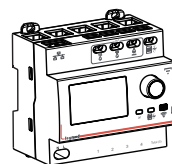

- Measurement coils (5 maximum)



- A protection device such as a circuit breaker or 2 A fuse



2/ The main switch must first be turned off, then after wiring up the installation, it should be turned back on so that the connected Ecometer is supplied with power at the same time.

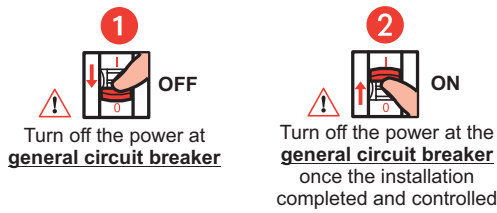

3/ Choose a position for the connected Ecometer in your electrical panel. This is connected via Wi-Fi or via an Ethernet cable (RJ 45 cable).

With your smartphone, check that the Wi-Fi signal is strong enough. If not, try and put your router closer to the electrical panel, add a Wi-Fi repeater or connect your Ecometer to your router with an Ethernet cable.

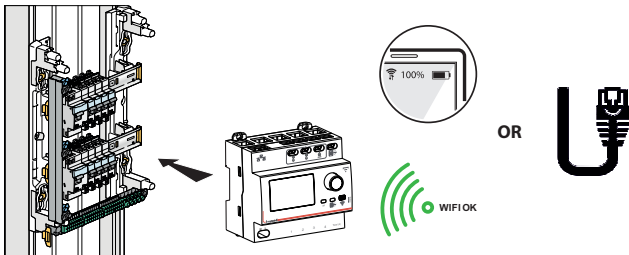

4/ Mount and wire up the connected Ecometer with its 2 A fuse protection in accordance with the wiring diagram, and connect your coils to the Ecometer via the fast-on connector.

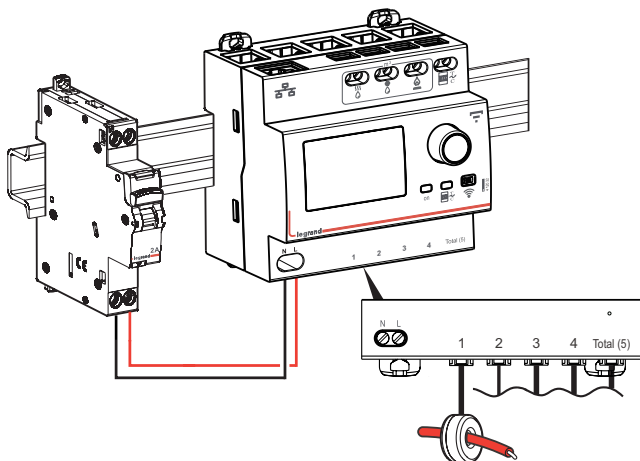

5. GENERAL CHARACTERISTICS

5.1 Illuminated signals

Description of possible states:

LED	Colour	Status	Description
		Continuous green indicator lamp	Product working
		Slow blinking green	CIS mode connected and data received from the CIS
		Fast blinking green	CIS mode disconnected or data not received from the CIS
		Flashing green	Product awaiting commissioning and connected via Wi-Fi or not
		Continuous red indicator lamp	Product awaiting commissioning and connected via Ethernet link

5.2 Product marking

- Front panel marked with indelible pad printing

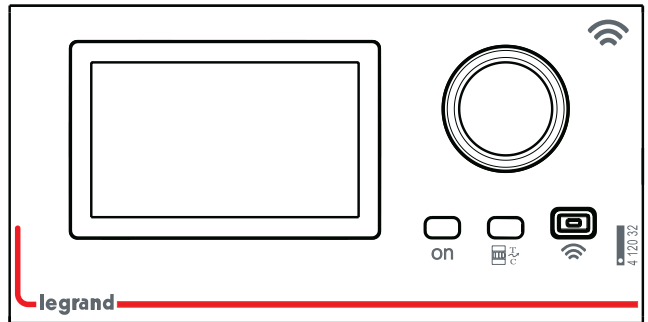

- Upper terminals marked with indelible pad printing

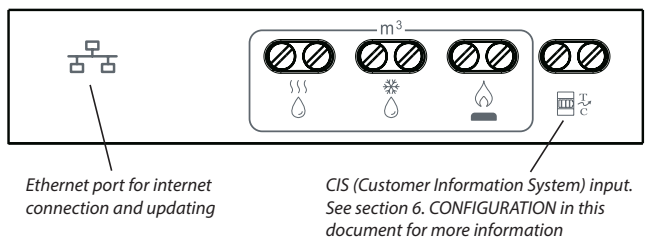

- Lower terminals marked with indelible pad printing



- Sides marked with a laser

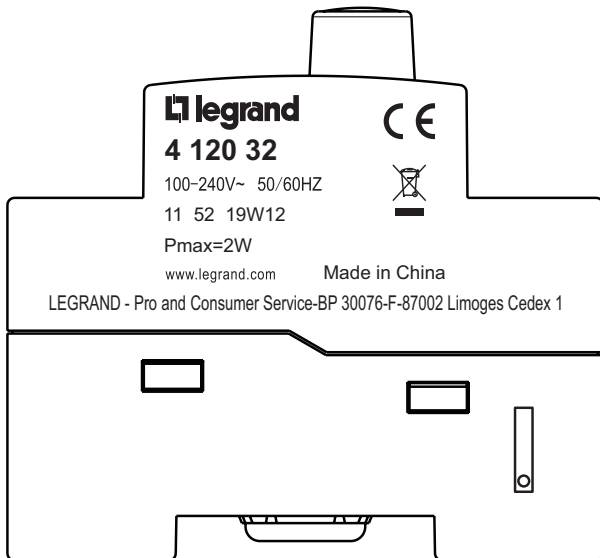

■ 5.3 Technical characteristics

Plastic materials:

- Self-extinguishing polycarbonate
- Heat and fire resistance according to standard IEC/EN 60695-2-12, glow-wire test at 960°C
- Classification UL 94/IEC/EN 60695-11-10:V1

Operating temperature: -25°C to +55°C

Storage temperature: -25°C to +55°C

Protection class:

- Protection class against direct contacts: IP2X (according to IEC/EN 60529)
- Protection class for the connection terminals against solid objects and liquids (wired product) : IP20 (according to IEC/EN 60529)
- Protection class for the device under a faceplate: IP40 (according to IEC/EN 60529)

Class II double insulation (product mounted in an enclosure)

Vibration resistance:

- According to standard IEC 60068-2-6
- Axes: x, y, z
- Frequency range: 5/100 Hz for 90 min
- Displacement (5/13.2 Hz): 1 mm
- Acceleration (13.2/100 Hz): 0.7 g (g=9.81 m/s²)

Average weight of the Ecometer: 0.23 kg

Volume of packaged product:

- Connected Ecometer: 1.005 dm³
- Measurement coil: 0.3 dm³

Standby consumption < 2 W (at 230 V ~)

6. CONFIGURATION

The Connected Ecometer can be used offline without an internet connection (directly on the product screen), or can be added to a “with Netatmo” connected installation and managed via the Home + Control app.

You can refer to section “7. NAVIGATION SCREEN” in this document if you want to understand how the interface is used.

■ 6.1 Language

- French (default setting)
- English

■ 6.2 Currency

- Euro € (default setting)
- Dollars \$

■ 6.3 Total consumption

The total consumption can come from a measurement coil connected to the device “Total” metering point or directly from the CIS (Customer Information System), if it is connected.

If the CIS (Customer Information System) is not connected (default scenario): the total consumption measurement will come from the coil connected to the “Total (5)” input.

If the CIS (Customer Information System) is connected and working: the total consumption will come from the CIS (to be connected). The coil connected to the “Total (5)” input can then feed back consumption data from a separate circuit.

In the Home + Control app, the detailed consumption of each line is updated hourly. It is therefore normal that during installation of the Connected Ecometer, the consumption data is at zero.

■ 6.4 Tariff management

The device gives you the option of choosing the tariff management mode for any associated time slots.

Choice of two tariffs:

- If you have a “Standard” tariff, you should enter the cost per kWh stated for example on your Electricity contract, on one of your bills or on your energy supplier’s online interface.
- If you have a “Peak/Off-Peak” tariff, you should enter the cost per kWh of the peak times and off-peak times, then you should indicate as many time slots as necessary so you can fill in the off-peak times stated on your electricity contract.

7. NAVIGATION SCREENS

To navigate between the various Connected Ecometer screens, you should use the thumbwheel on the front of the product.

7.1 Setting the language selection

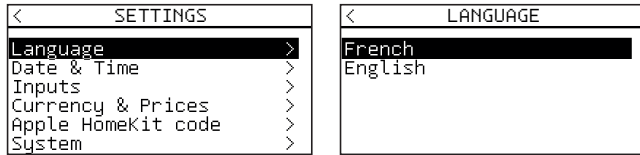

7.2 Setting the date and time

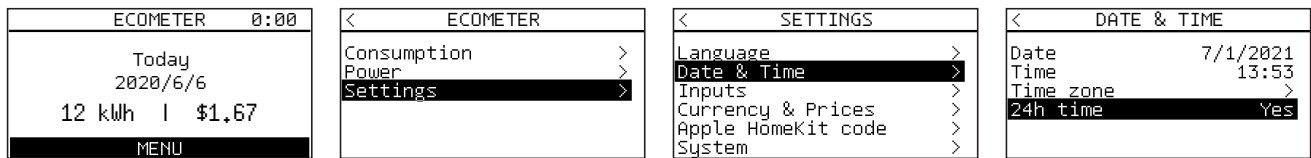

7.3 Selecting the currency

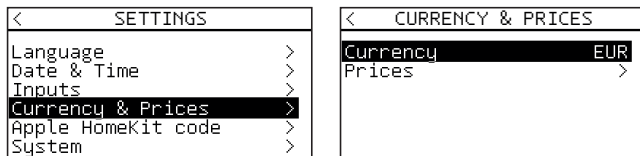

7.4 Selecting the Electricity tariff

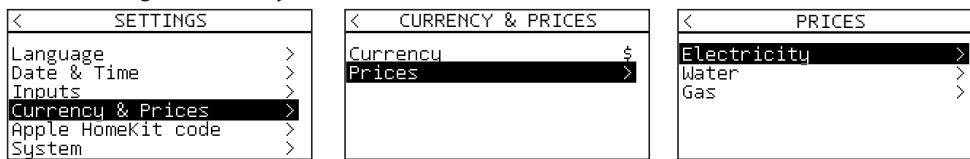

To set your electricity contract tariff, select "Tariffs" then "Electricity".

Standard tariff

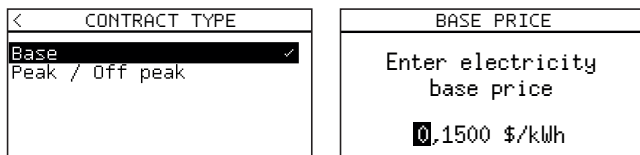

Set the Standard tariff by entering the cost per kWh stated for example on your Electricity contract, on one of your bills or on your energy supplier's online interface.

Electricity tariff

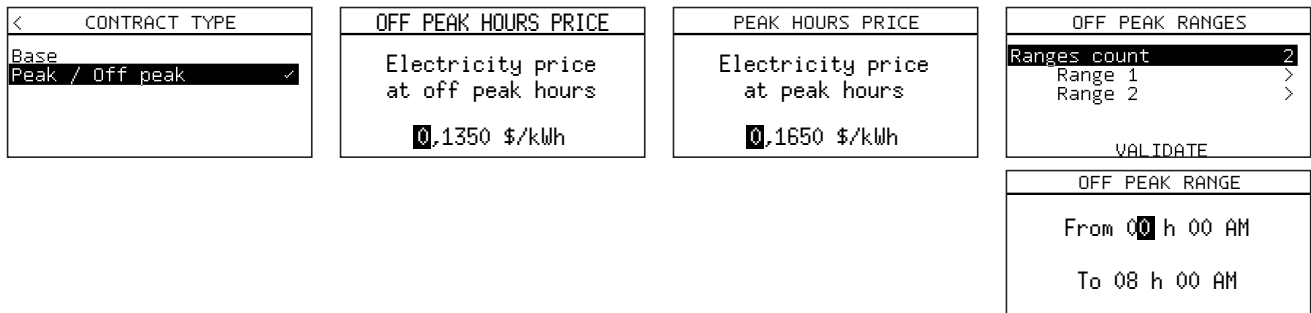

If you have subscribed to a Peak/Off-Peak contract, the electricity tariff varies according to the time of day. Enter the peak and off-peak tariffs per kWh, then create as many time slots as necessary to fill in the off-peak times for your electricity contract.

This information is usually stated on your contract, on one of your bills or on your energy supplier's online interface.

■ 7.5 Setting the pulse inputs

Set the pulse coefficients on your gas and water meters. This information can usually be found on your gas bill and on the water meter valve.

< SETTINGS > Language > Date & Time > Inputs > Currency & Prices > Apple HomeKit code > System >	< INPUTS > Line 1 > Line 2 > Line 3 > Line 4 > Line 5 > Gas >	< Gas > Coefficient >	GAS COEF. Enter gas quantity by pulse 00,25 dm ³ /imp
< SETTINGS > Language > Date & Time > Inputs > Currency & Prices > Apple HomeKit code > System >	< INPUTS > Line 2 > Line 3 > Line 4 > Line 5 > Gas > Cold water >	< COLD WATER COEF. > Enter cold water quantity by pulse 01,00 L/imp	

Enter the cost per m³ of gas and water stated on your contract

< SETTINGS > Language > Date & Time > Inputs > Currency & Prices > Apple HomeKit code > System >	< CURRENCY & PRICES > Currenca \$ > Prices >	< PRICES > Electricity > Water > Gas >	< GAS PRICE > Enter the price of 1m ³ of gas 0,00 \$/m ³
			< WATER PRICE > Enter the price of 1m ³ of water 0,00 \$/m ³

■ 7.6 Electricity consumption rows

< SETTINGS > Language > Date & Time > Inputs > Currency & Prices > Apple HomeKit code > System >	< INPUTS > Line 1 > Line 2 > Line 3 > Line 4 > Line 5 > Gas >	< Line 1 > Rename >	< Line 1 > Line 1 _____ VALIDATE
--	---	----------------------------------	--

Rename the electricity consumption rows if you wish (rows 1 to 5)

■ 7.7 Display of detailed consumption per source

View cumulative daily, monthly or annual total consumption.

< ECOMETER > Consumption > Power > Settings >	< CONSUMPTION > Electricity > Water > Gas >	< CONSUMPTION > Line 1 > Line 2 > Line 3 > Line 4 > Line 5 > Cold water >	< Line 1 > Day > Month > Year >
			< Line 1 > 2021/7/1 9,6 kWh < \$1,44 > BACK

■ 7.8 Display of the power

< ECOMETER > Consumption > Power > Settings >	< POWER > Totale 22.2 kW A/C 9 kW Outlets 3.4 kW Heating 5 kW Hot water 4.8 kW BACK
--	---

■ 7.9 Data storage period

Firmware version	In years	In months	In days
< V021	4	6	14
≥ V021	4	12	30

■ 7.10 Pulse input

- Connected to the gas, hot water/cold water meter
- Unit used: m³
- The ratio between the number of pulses and m3 can be configured. By default, the value is 1000:1.

8. COMPLIANCE

Compliance with standards:

EMC EN 61326: 2013

Safety EN 61010-1: 2010

- Complies with Electromagnetic Compatibility (EMC) Directive no. 2014/30/EU
- Complies with Low Voltage Directive no. 2014/35/EU.
- Electromagnetic compatibility:
 - EN 55014-1: 2006 + A1: 2009, Part 1: CISPR 14-1: 2005 + A1: 2008
 - EN 61000-4-2: 2009, Part 4-2: IEC 61000-4-2: 2008
 - EN 61000-4-3: 2006 + A1: 2008 + A2: 2010, Part 4-3: IEC 61000-4-3: 2006 + A1: 2007 + A2: 2010
 - EN 61000-4-4: 2004 + A1: 2010, Part 4-4: IEC 61000-4-4: 2004 + A1: 2010
 - EN 61000-4-5: 2006, Part 4-5: IEC 61000-4-5: 2005
 - EN 61000-4-6: 2009, Part 4-6: IEC 61000-4-6: 2008
 - EN 61000-4-16: 1998 + A1: 2004 + A2: 2011, Part 4-16: IEC 61000-4-16: 1998 + A1: 2001 + A2: 2009
 - EN 61189-2, Part 2: IEC 61189-2
 - EN 61543: 1995 + corr. Dec. 1997 + A11: 2003 + A12: 2005, IEC 61543: 1995 + A2: 2005
- EN 50557: 2011
- EN 60898-1: 2003 + corr. Feb. 2004 + A1: 2004 + A11: 2005 + A12: 2008, Part 1: IEC 60898-1: 2002, mod. + A1: 2002, mod
- EN 60898-2: 2006, Part 2: IEC 60898-2: 2000, mod. + A1: 2003, mod
- EN 60947-5-1: 2004 + corr. Jul. 2005 + A1: 2009, Part 5-1: IEC 60947-5-1: 2003 + A1: 2009
- EN 61008-1: 2004 + A11: 2007 + A12: 2009, Part 1: IEC 61008-1: 1996, mod. + A1: 2002, mod
- EN 61009-1: 2004 + A11: 2008 + A12: 2009 + A13: 2009, Part 1: IEC 61009-1: 1996, mod. + A1: 2002, mod. + corr. May 2003
- EN 61558
- EN 62019

The product can be used in the conditions defined by standard IEC/EN 60947.

Respect for the environment – Compliance with EC directives:

- Complies with directive 2011/65/EU known as “RoHS II”
- Complies with Directive 91/338/EC of 18/06/91 and decree 94-647 of 27/07/2004
- Complies with REACH

Plastic materials:

- Halogen-free
- Product marking complies with standards ISO 11469 and ISO 1043
- EN ISO 306: 2004
- ISO 7000: 2004

Packaging:

- Design and industrialisation comply with decree 98-638 of 20/07/98 and Directive 94/62/EC