

Mosaic™ with Netatmo Connected switch with neutral (with dimmer option)

Cat. No(s): 0 777 08LA

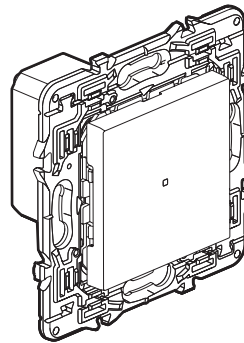

1. USE

Connected switch with neutral (with dimmer option), configured by default as ON/OFF.

Can be combined with one or more wireless lighting controls (dimmer mode can be activated from the Home + Control app) and/or mechanical push-buttons.

For local or remote control of your lighting.

Easy to install in place of a standard switch in a box 40 mm deep (minimum). Fixing with claws and/or screws.

2. RANGE

Description	White
Product for use in conjunction with the starter "with Netatmo". With LED indicator (configuration) and RESET button (hidden) used to return in factory settings. Delivered with protection cover.	0 777 08LA

3. DIMENSIONS (mm)

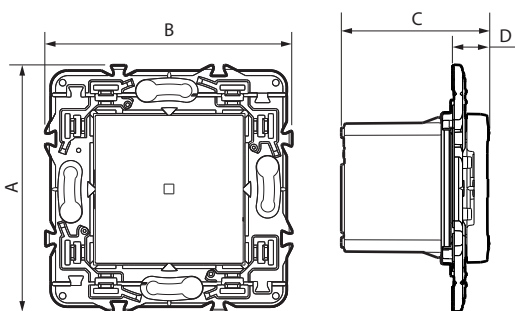

A	B	C	D
74	74	46	11

4. CONNECTION

Terminal type : with screws

Terminal capacity: 1 x 2.5 mm² - 2 x 1.5 mm²

Stripping length: 7 mm

Screwdriver: 3 mm flat

5. OPERATION

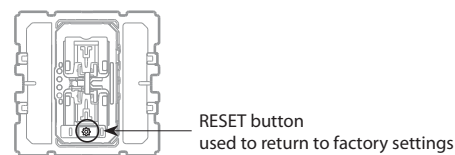
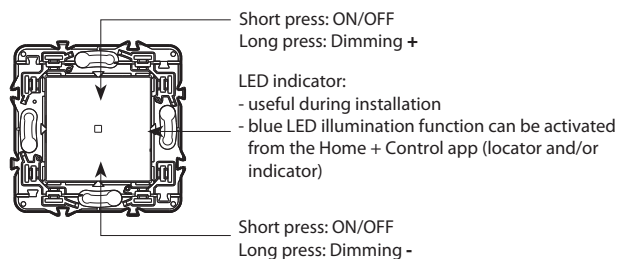

6. TECHNICAL CHARACTERISTICS

6.1 Mechanical characteristics

Protection against impacts: IK 04

Protection against solid bodies and liquids: IP 20

6.2 Material characteristics

Support: PA 6.6 + Galfan Steel

Mechanism casing: PC

Rocker: PC White RAL 9003

Halogen-free

UV-resistant

Self-extinguishing:

850°C/30 s for insulating components holding live parts in place.

650°C/30 s for other insulating components.

6.3 Electrical characteristics

Voltage: 110/240 V~

Power: 150 W

Frequency: 50/60 Hz

Standby consumption: 3.7 mA

Zigbee technology 2.4 GHz to 2.4835 GHz

Power level: < 100 mW

Range: 200 m of unobstructed space

10 m between products indoors

6.4 Climate characteristics

Usage temperature: +5°C to +45°C

Storage temperature: 0°C to +45°C

7. CARE

Clean the surface with a cloth.

Do not use acetone, tar-removing cleaning agents or trichloroethylene.

Resistant to the following products:

Hexane, methylated spirit, soapy water, diluted ammonia, bleach diluted to 10%, window-cleaning products, pre-impregnated wipes.

Resistance to hospital grade cleaning products:

Anios, surfanios, bactylsine, diluted hydrogen peroxide (35%).

Caution: Always test before using special cleaning products.

8. STANDARDS AND APPROVALS

Compliant with installation and manufacturing standards.

See e-catalogue.

The undersigned, LEGRAND, declares that the radio-electric equipment type (0 777 08LA) complies with directive 2014/53/EU.

The full text of the EU declaration of conformity is available on the following website: www.legrand.com/ecatalogue