

Single-phase connected energy meter

Cat.Nos : 4 120 15 - 1 991 18
 Included in packs : 4 121 92/93 - 1 991 56



Home + Control



CONTENT	Page
1. Characteristics	1
2. Operating position	2
3. Connections	3
4. Configurations	4
5. Marking	5
6. Compliances and approvals	5

1. CHARACTERISTICS

1.1 Use

Consumption

The connected energy meter allows the measurement and visualization of the electrical consumption of a circuit or an entire home via a smartphone, using the Home + Control app, in single-phase AC through the current transformer associated.

This connected version offers the following functions:

- Real-time measurement: automatically reports electrical consumption via the associated current transformer.
- Consumption history: viewable via the Home + CONTROL app.

Photovoltaic

The energy meter can be integrated into a solar production installation by being positioned upstream of the photovoltaic electrical installation. When associated with other connected modules (see "I measure and control my production" packs), it will display the production of photovoltaic panels.

The energy meter cannot operate alone. Another module must be installed in the consumption section (see technical details).

Installation conditions

Using a single-phase connected energy meter requires the prior installation of:

- A Control Module Cat.No 4 121 81

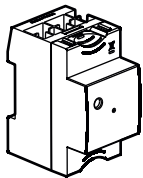

- Or a connected starter pack "with Netatmo" (Principle drawing, works with any type of connected starter pack "with Netatmo").



- Or any other "with Netatmo" connection interfaces.

1.2 Range

The energy meter is included in photovoltaic packs:

- Cat.No 4 121 92/93
- Cat.No 1 991 56

1.3 Technical data of the energy meter

Width	1 module (17,7 mm)
Nominal primary current (I _{pn})	80 A AC
Power consumption	0.3 W Maxi
Nominal supply voltages	100 V to 240 V AC
Rated operational voltage (U _e)	U _e = 100 to 240 V
Nominal frequency	50 Hz / 60 Hz
Rated frequency	50 Hz / 60 Hz
Impulse withstand voltage (U _{imp})	4 kv
Overvoltage category	III
Operating ambient temperature	Min. = + 5 °C Max. = + 45 °C
Storage ambient temperature	Min. = - 40 °C Max. = + 70 °C
Altitude influence	No influence up to 2 000 m
Protection degrees	Terminal protection: IP2x (wired device) Front face protection: IP3XD Class II, front face covered Shock protection: IK04
Pollution degree	2
Plastic material	Self-extinguishing polycarbonate. UL 94 Classification: V0
Weight	91 g
Compatible application	 Home + Control Available for free on Google Play or App Store

1. CHARACTERISTICS (continued)

1.4 Technical data of the current transformer

Maximum primary current measured	80 A AC
Transformation ratio	1000 : 1
Nominal thermal short-circuit current	$I_{th} = 3 \text{ kA effective/1s}$
Nominal dynamic current	$I_{dyn} = 9 \text{ kA}$
Nominal voltage level for insulation	3 kV effective value 50 Hz/1min
Insulation class	Measurement sensor class A according to EN/IEC 61869-2
Measurement accuracy	Measurement chain accuracy Module + Current transformer: +/-1% for a measured current >2A and $\cos\phi \geq 0.8$

1.5 Dimensions

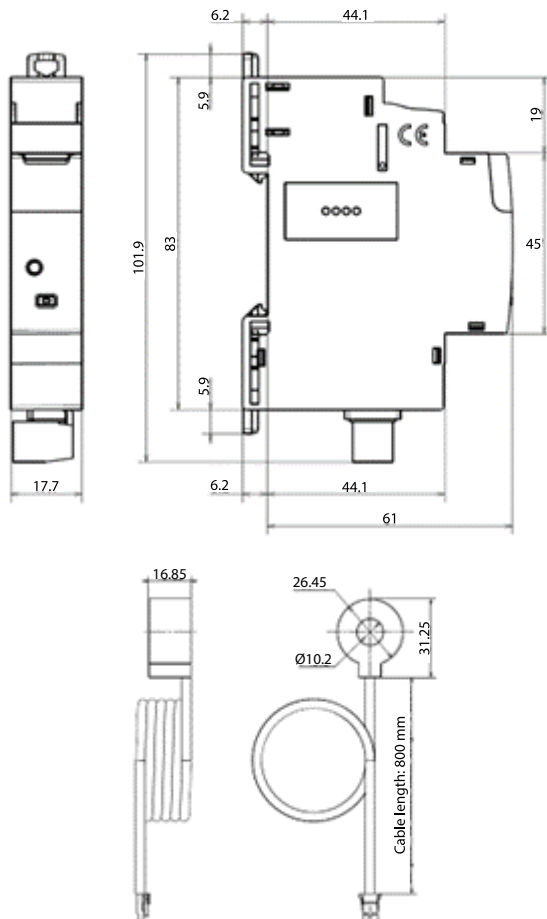

1.6 Circuit identification

Circuit identification is done using a label inserted into the label holder located on the front face of the connected energy meter.

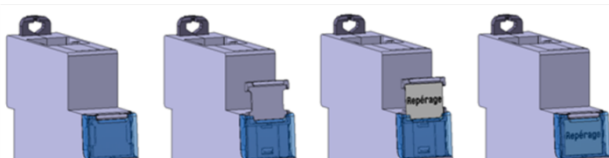

2. OPERATING POSITION

The single-phase connected energy meter is mounted on an EN/IEC 60715 or DIN 35 symmetrical rail.

Three mounting options:

Vertical mounting

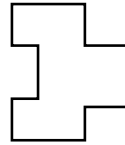

Horizontal mounting

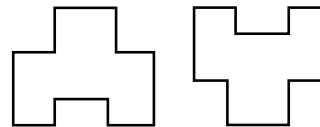

Flat mounting

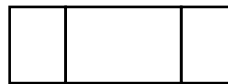

Recommended tool for rail mounting:
Blade screwdriver (max. 5.5 mm).

Positioning in a row

The product profile and terminal positioning allow the passage of single-phase, three-phase, and Plug-In connection combs at the top of the product. Therefore it is possible to freely choose the position of the connected energy meter in the row and to connect products on the same rail using a comb.

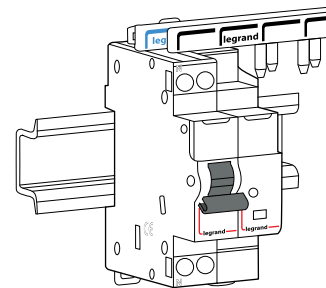

In case of maintenance, it is possible to replace a connected energy meter in the middle of a combed row upstream without disconnecting other products.

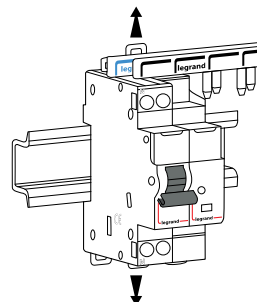

1. Set the claws to the unlocked position

2. OPERATING POSITION (continued)

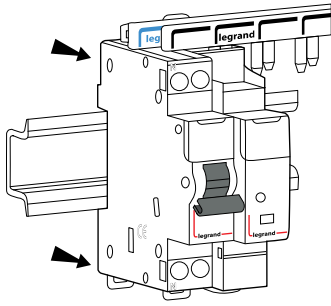

2. Pull the device forward to release it from the rail

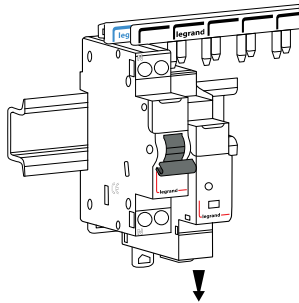

3. Pull the device downwards to fully disengage it from the comb teeth.

3. CONNECTIONS

3.1 Current transformer connection

Connection by inserting the current transformer connector into the slot provided on the connected energy meter until it locks (clips).

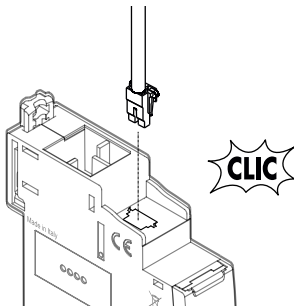

If necessary, use a small screwdriver on the clips to disconnect it.

Current transformer capacity				
Conductor section	1.5 mm ²	2.5 mm ²	6mm ²	10 mm ² to 25 mm ²
Number of flexible or rigid conductors	8	5	3	1

Wiring Diagram

The current transformer can be connected to a circuit, general meter, or photovoltaic production. Here are the wiring diagrams for:

- Load measurement:

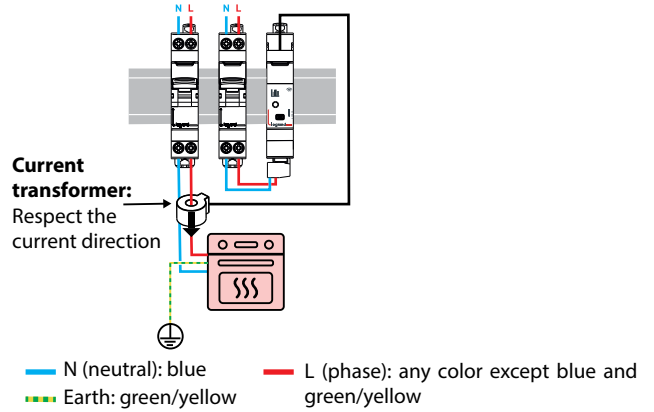

- Total consumption measurement:

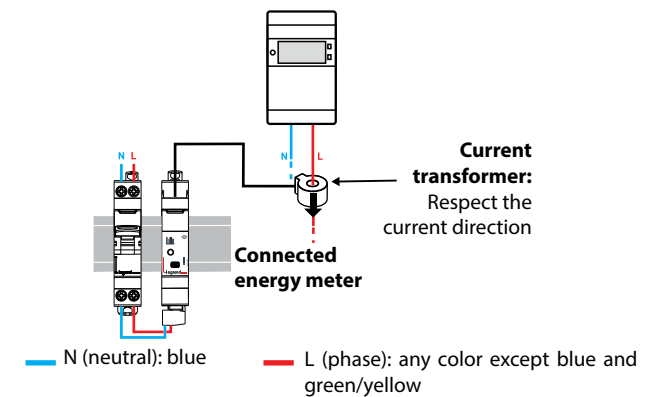

Multiple current transformers can be placed on the main supply line (total consumption), for example: the current transformer of the eco-meter or the connected energy meter.

If multiple connected devices measure total consumption, the total consumption information displayed on the app is prioritized as follows:

- from the connected eco-meter
- from the connected load-shedding device
- from the energy meter

- Photovoltaic production measurement:

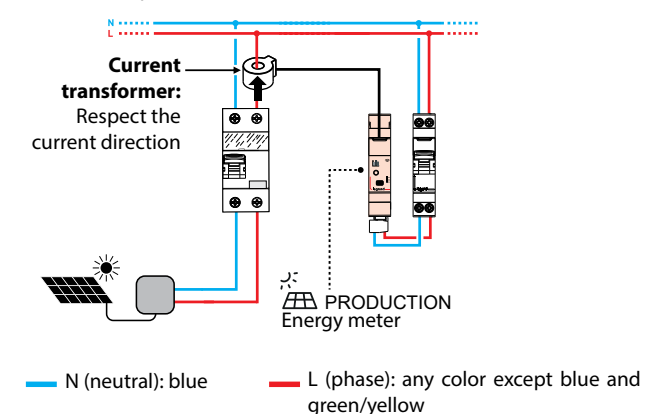

The energy meter cannot operate alone. It provides the measurement of photovoltaic panels (production part). The consumption measurement function must be ensured by a connected load-shedding device or another single-phase energy meter "with Netatmo" (refer to technical documentation).

WARNING: This system is not compatible with installations that include a connected Ecocompteur and/or storage batteries.

3. CONNECTIONS (continued)

3.2 Connector connection

The connection of the power supply to the connector is done as follows:

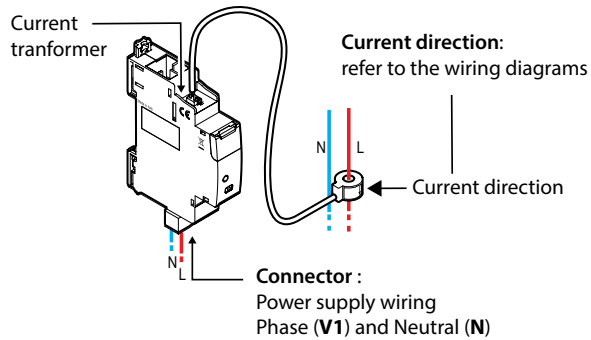

Wire the connected energy meter after a C2 to C16 protection circuit breaker according to the cable section used.

If conditions allow it, the existing electrical protections in the electrical panel can be reused for this purpose.

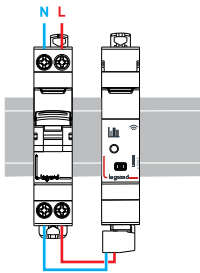

3.3 Screw terminal connections

Types of terminals	Cage terminals
Depth	9 mm
Recommended stripping length	8 mm
Screw head	Slotted 3.5 mm
Screw type	M3
Tightening torque	0,5 Nm

Here are the sections accepted by the screw terminal for connecting copper conductors:

	Without ferrule	With ferrule
Rigid cable	1x (1 to 2.5 mm ²)	-
	2x (1 to 1.5 mm ²)	
Flexible cable	1x (1 to 2.5 mm ²)	1 x (1 to 1.5mm ²)
	2 x (1 to 1.5mm ²)	

4. CONFIGURATIONS

Configuration and data visualization are done via smartphone with the Home + Control app.

4.1 Indicators

Indicators are visible on the front face.

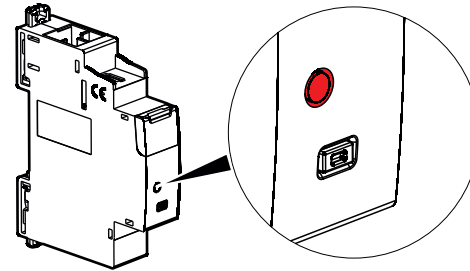

In configuration :

Color	Status	Meaning
Red	Steady	Transient state. Connected energy meter not paired with the radio network
Green	Steady	Transient state. Connected energy meter paired with the radio network (when the radio network is still open)
	Off	Normal state. Connected energy meter paired with the radio network (when the radio network is closed)

In operation:

Color	Status	Meaning
	Off	No problem detected
Red	Blinking	Three-phase installation: Check if the connected energy meter is connected to the same phase as the current transformer. Any installation: Significant phase shift between voltage and current on the line caused by a load with an unfavorable power factor (motor, pool pump, certain lighting, etc.)

4.2 Removing a connected energy meter from a connected installation

Resetting a connected energy meter is done to remove it from a connected installation.

This can be easily done by pressing the configuration button on the connected energy meter for more than 5 seconds until the configuration indicator lights up red steadily. It is then no longer affiliated with the Control Module / Control Socket.

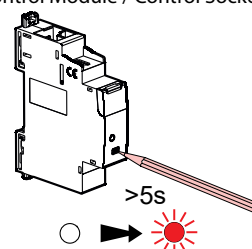

4. CONFIGURATIONS (continued)**■ 4.3 Adding a connected energy meter to a connected installation.**

REMINDER: To create a connected installation, a Control Module Cat.No 4 121 81 is required; either a connected starter pack; or any other "with Netatmo" connection interface.

The main circuit breaker must be turned off beforehand.

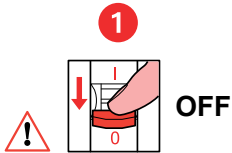

After wiring and checking the installation, replace the faceplate so that no live parts are accessible. Turn the main circuit breaker back on so that the connected devices are powered simultaneously and connect to the network.

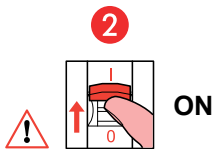

Complete the installation in the Legrand Home + Control app. Download the Home + Control app and follow the instructions to add the connected product to your installation.



Home + Control

**■ 4.4 Other configurations and actions**

All other functionalities and configurations (e.g., setting up scenarios, schedules, etc.) are explained step-by-step directly in the smartphone app.

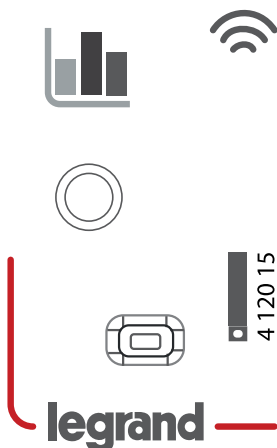
5. MARKING**6. COMPLIANCES AND APPROVALS**

Compliance with standards:
EN/IEC 61010-1

Environmental respect compliance – Response to European Union directives:

- Compliance with Directive 2011/65/EU known as "RoHS II" which bans hazardous substances such as lead, mercury, cadmium, hexavalent chromium, polybrominated biphenyls (PBB), and polybrominated diphenyl ethers (PBDE)
- Compliance with Directives 91/338/EEC of 18/06/91 and Decree 94-647 of 27/07/04.
- REACH regulation compliance

Plastic Materials:

- Halogen-free plastic materials.
- Marking of parts in accordance with ISO 11469 and ISO 1043.
- EN ISO 306:2004, Plastics - Thermoplastic materials - Determination of Vicat softening temperature (VST) (ISO 306: 2004)
- ISO 7000:2004, Graphical symbols for use on equipment - Index and synopsis

Packaging

- Design and manufacture of packaging in compliance with Decree 98-638 of 20/07/98 and Directive 94/62/EC.