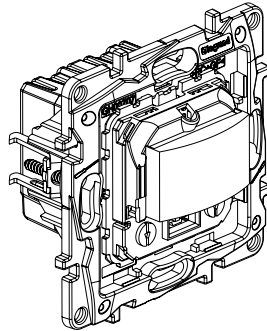

Niloé™ Step
Motion sensorCat. No(s): 8 640 65 - 8 641 65
8 643 65 - 8 645 65**1. USE**

Automatic switch with neutral, with infrared detection.
Switches automatically on in case of movement detection and low natural light level.
Detection field: 120° - Detection : 8 m
Supplied with support frame cover plates and plates.
Mechanisms supplied with protection cover.
To be equipped with plates one or several gangs.
Flush-mounting or surface-mounting.
Screw or claw fixing.

2. RANGE

Description	Mechanism only	Cover plate only			
		White	Aluminium	Black	Sand
Automatic switch 3-wires with neutral	8 640 65	8 641 65	8 643 65	8 645 65	-

3. DIMENSIONS (mm)

Cat. No 8 640 65

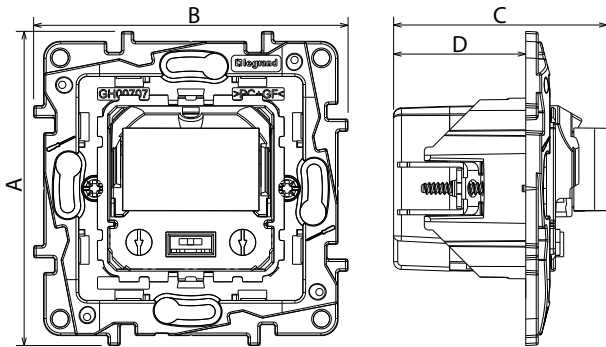

References	A	B	C	D
8 640 65	75.8	75.8	51.5	32

4. CONNECTION

Type of terminals: with screws
Terminal capacity: 2 x 2.5 mm²
Stripping length (mm): 8 mm
Flexible or rigid cables compatible

5. TECHNICAL CHARACTERISTICS

■ 5.1 Mechanical characteristics

Protection against solid bodies and liquids: IP 20
Protection against impact: IK 04

■ 5.2 Material characteristics

Material : - Mechanism housing: PC
- Halogen free
- UV resistant
- Claws: steel
Material of the support: - PC + FV
- Halogen free

Self-extinguishing:

- + 850° C / 30 s for insulating parts holding live parts in place
- + 650° C / 30 s for other parts made of insulating materials

■ 5.3 Electrical characteristics

- Voltage: 100 - 240 V~
- Frequency: 50/60 Hz
- Power accepted by lamp type:
 - LEDs : 3 W to 100 W
 - Fluocompact: 3 W to 100 W
 - LEDs, CFLs, Halogen, with ferromagnetic or electronic ballast: 3 VA à 250 VA
 - Halogen lamps 230 V, incandescent lamps: 3 W to 250 W
(voir tableau des charges sur e.catalogue)
- Standby consumption: 0.02 W
- Time delay adjustable: from 10 s to 10 mn
- Adjustable luminosity threshold: from 5 Lux to 1275 Lux

■ 5.4 Climatic characteristics

Storage and use temperature: - 5° C to + 35° C

6. MAINTENANCE

Surface cleaning with a cloth.
Do not use: acetone, tar remover, trichloroethylene.

Maintenance with the following products: Hexane (EN 60669-1), Methylated spirit, Soapy water, Diluted ammonia, Bleach diluted to 10%, Window-cleaning products.

7. STANDARDS AND APPROVALS

Caution: A preliminary test should be carried out if other specific cleaning products are to be used.

Compliance with standards of installation and manufacturing.
Refer to e. catalogue.