

## Niloé™ Step Two-way switch 16 AX

Cat. No(s): 8 640 02/04 - 8 641 02/04 - 8 643 02/04  
8 645 02/04 - 8 646 02/04

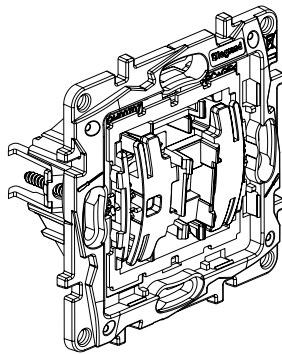

8 640 02

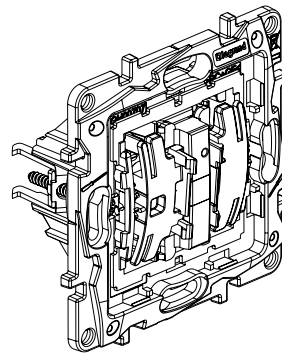

8 640 04

### 1. USE

Lighting controls mechanisms.  
Supplied with protection cover.  
Flush or surface mounting.  
Screw or screw and claw mounting with claws.  
To be fitted with one-gang or multi-gang plates.

### 2. RANGE

Description	Mechanism only	Cover plate only			
		White	Aluminium	Black	Sand
Two-pole switch 16 AX	8 640 02	8 641 02	8 643 02	8 645 02	8 646 02
Two-pole indicator switch 16 AX	8 640 04	8 641 04	8 643 04	8 645 04	8 646 04

### 3. DIMENSIONS (mm)

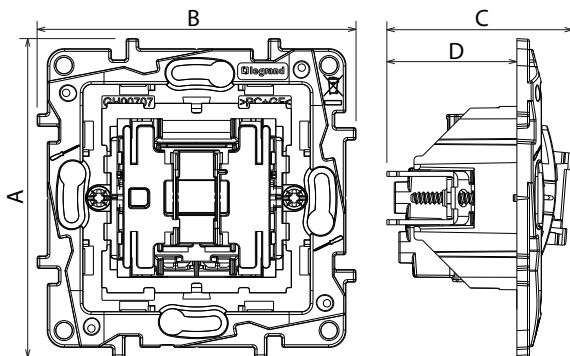

A	B	C	D
75.8	75.8	44.2	31

### 4. CONNECTION

Type of terminals: screw  
Terminal capacity: 2 x 2.5 mm<sup>2</sup>  
Stripping length: 10 mm  
Compatible with flexible or rigid cables.

### 5. TECHNICAL CHARACTERISTICS

#### ■ 5.1 Mechanical characteristics

Protection against solid bodies and liquids: IP 20  
Protection against mechanical impact: IK 04

#### ■ 5.2 Material characteristics

Material: - Box of the mechanism: PC  
- Halogen free  
- UV resistant  
- Claws: steel

Material of the support : - PC  
- Halogen free

Self-extinguishing:  
+ 850° C / 30 s for insulating parts holding live parts in place.  
+ 650° C / 30 s for other parts made of insulating materials.

#### ■ 5.3 Electrical characteristics

Voltage: 250 V~  
Current: 16 AX,  
Maximum power on integrated ballast lamps: 200 W  
Frequency: 50/60 Hz  
Light indicator: LED 230V - 3 mA

#### ■ 5.4 Climatic characteristics

Storage and use temperature: - 5° C to + 35° C

## 6. CLEANING

Surface cleaning with a cloth.

Do not use: acetone, tar remover, trichloroethylene.

Maintenance with the following products:

Hexane (EN 60669-1), Methylated spirit, Soapy water, Diluted ammonia, Bleach diluted to 10%, Window-cleaning products.

**Caution:** A preliminary test should be carried out if other specific cleaning products are to be used.

## 7. STANDARDS AND APPROVALS

Compliant with installation and manufacturing standards.

See e.catalogue.