

Valena™ Next

Connected switch without neutral

125 W LED with dimmer option

Cat. Nos: 7 418 10A/40A/70A

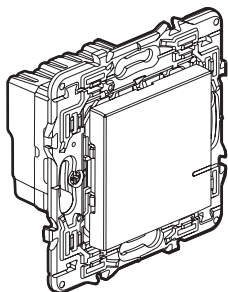

7 418 10A

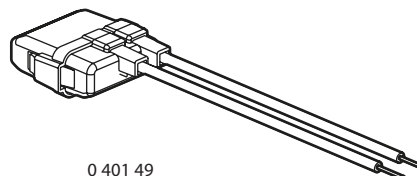

0 401 49

1. USE

Connected switch without neutral with dimmer option, configured by default as ON/OFF.

Can be combined with one or more wireless lighting controls (dimmer mode can be activated from the Home + Control app).

For local or remote control of your lighting.

Supplied with an active power compensator (Cat. No. 0 401 49), mandatory to ensure optimum operation with commercially-available lamps. One compensator per lighting circuit is sufficient.

Easy to install in place of a standard switch in a box 40 mm deep (minimum).

Claw and/or screw fixing.

2. RANGE

Description	White	Alu	Black
Product for use in conjunction with the starter pack. With LED indicator (configuration) and RESET button (hidden) used to return to factory settings. Supplied with site protection covers.	7 418 10A	7 418 40A	7 418 70A

3. DIMENSIONS (mm)

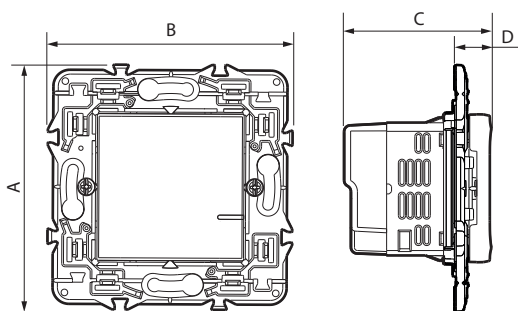

A	B	C	D
74	74	44.5	12

4. CONNECTION

Terminal type : wih screws

Terminal capacity: 2 x 1.5 mm² or 2 x 2.5 mm²

Stripping length:

8 mm flat screwdriver: 3 mm

5. OPERATION

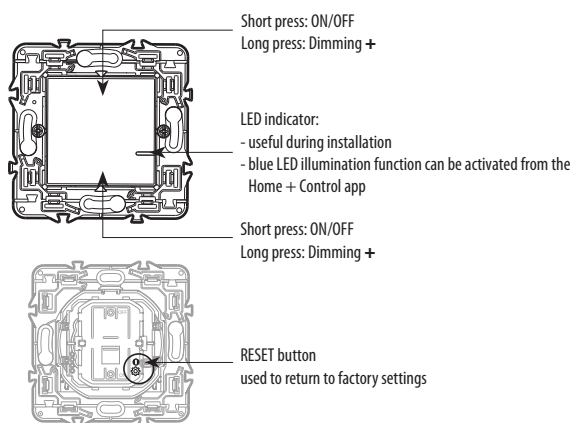

6. TECHNICAL CHARACTERISTICS

■ 6.1 Mechanical characteristics

Protection against impacts: IK 04

Protection against solid bodies/liquids: IP 20

■ 6.2 Material characteristics

Grid: 6.6 PA + Galfan steel

Mechanism casing: PC

Rocker: PC

Halogen-free

UV-resistant

Self-extinguishing:

850°C/30 s for insulating components holding live parts in place.

650°C/30 s for other insulating components.

■ 6.3 Electrical characteristics

Voltage: 110-240 V~

Power: 125 W

Frequency: 50/60 Hz

Standby consumption: 2.2 mA

Zigbee technology 2.4 GHz to 2.4835 GHz

Power level: < 100 mW

Range: 200 m of unobstructed space

10 m between products indoors

■ 6.4 Climate characteristics

Usage temperature: +5°C to +45°C

Storage temperature: 0°C to +45°C

7. CARE

Clean the surface with a cloth.
Do not use acetone, tar-removing cleaning agents or trichloroethylene.

Resistant to the following products:
Hexane, methylated spirit, soapy water, diluted ammonia, pure bleach diluted to 10%, window-cleaning products, pre-impregnated wipes.

Caution: Always test before using special cleaning products.

8. STANDARDS AND APPROVALS

Compliant with installation and manufacturing standards.
See e-catalogue.

The undersigned, LEGRAND, declares that the radio-electric equipment type (7 418 10A/40A/70A) complies with directive 2014/53/EU.

The full text of the EU declaration of conformity is available on the following website: www.legrand.com/ecatalogue