

Céliane™ with Netatmo

Connected switch 125 W LED without neutral with dimmer option

Cat. Nos: 0 677 21A/71A - 0 648 91A

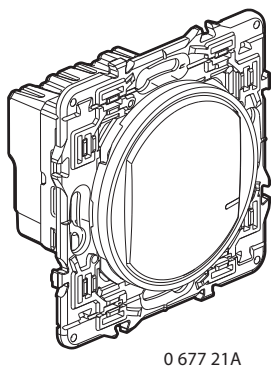

0 677 21A

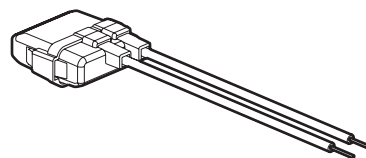

0 401 49

1. USE

Connected switch without neutral 125 W LED with dimmer option, configured by default as ON/OFF (dimmer mode can be activated from the Home + Control app).

Can be combined with one or more wireless lighting controls.

For local or remote control of your lighting.

Supplied with an active power compensator (Cat. No. 0 401 49), mandatory to ensure optimum operation with commercially-available lamps. One compensator per lighting circuit is sufficient.

Easy to install in place of a standard switch in a box 40 mm deep (minimum).

2. RANGE

Description	White	Titanium	Graphite
Product for use in conjunction with the starter pack. With LED indicator (configuration) and RESET button (hidden) used to return to factory settings. Supplied site protection covers.	0 677 21A	0 677 71 A	0 648 91A

3. DIMENSIONS (mm)

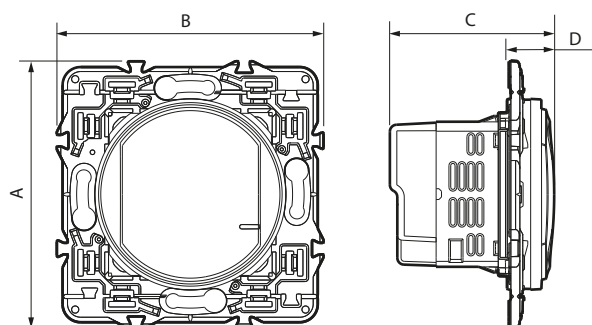

A	B	C	D
74	74	46	13

4. CONNECTION

Terminal type : with screws

Terminal capacity: 2 x 1.5 mm² or 2 x 2.5 mm²

Stripping length: 8 mm

Flat screwdriver: 3 mm

5. OPERATION

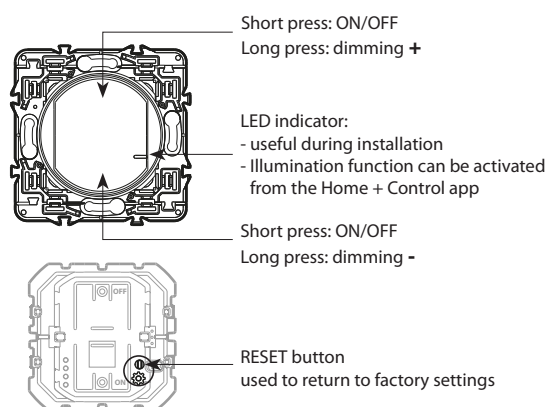

6. TECHNICAL CHARACTERISTICS

6.1 Mechanical characteristics

Protection against impacts: IK 04

Protection against solid bodies/liquids: IP 20

6.2 Material characteristics

Grid: 6.6 PA + Galfan steel

Mechanism casing: PC

Rocker: ABS

Halogen-free

UV-resistant

Self-extinguishing:

850°C/30 s for insulating components holding live parts in place.

650°C/30 s for other insulating components.

6.3 Climate characteristics

Usage temperature: + 5°C to + 35°C

Storage temperature: 0°C to + 45°C

6.4 Electrical characteristics

Voltage: 110-240 V~

Power: 125 W

Frequency: 50/60 Hz

Standby consumption: 2.2 mA

Zigbee technology 2.4 GHz to 2.4835 GHz

Power level: < 100 mW

Range: 200 m of unobstructed space

10 m between products indoors

Céliane™ with Netatmo

Connected switch 125 W LED without neutral with dimmer option

Cat. Nos: 0 677 21A/71A - 0 648 91A

7. CARE

Clean the surface with a cloth.

Do not use acetone, tar-removing cleaning agents or trichloroethylene.

Resistant to the following products:

Hexane, methylated spirit, soapy water, diluted ammonia, bleach diluted to 10%, window-cleaning products, pre-impregnated wipes.

Caution: Always test before using special cleaning products.

8. ACCESSORIES

Replacement rocker plate: 0 648 15: White

0 648 25: Titanium

0 648 35: Graphite

9. STANDARDS AND APPROVALS

Compliant with installation and manufacturing standards.

See e-catalogue.

The undersigned, LEGRAND, declares that the radio-electric equipment type (0 677 21A/71A - 0 648 91A) complies with directive 2014/53/EU.

The full text of the EU declaration of conformity is available on the following website: www.legrand.com/ecatalogue