

EMS CX³ - Pulse concentrator module

Cat. N° : 4 149 26



Contents	Pages
1. Description - Use	1
2. Range	1
3. Overall dimensions.....	1
4. Preparation - Connection	1
5. General characteristics	4
6. System architectures.....	7
6.1 Stand-alone.....	7
6.1.1 with local addressing.....	7
6.1.2 with remote addressing.....	8
6.2 Supervised.....	9
6.2.1 with local addressing.....	9
6.2.2 with remote addressing.....	11
7. Compliance and approvals	13

1. DESCRIPTION - USE

- . Module dedicated to Energy Management System (EMS CX³) use.
- . It collects, memorises and transmits pulses in output from electrical, gas, water counters or from the pulse output of multifunction measuring devices.

Symbol:



2. RANGE

- . Cat. n° 4 149 26: Pulse Concentrator Module; 3 inputs from voltage-free SPST-NO contact with one common terminal.

Width:

- . 1 module. 17,8 mm width.

3. OVERALL DIMENSIONS

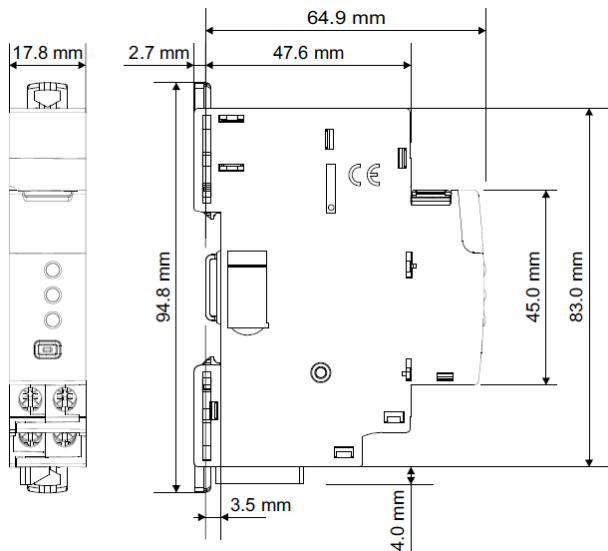

4. PREPARATION - CONNECTION

Fixing:

- . On symmetric rail EN/IEC 60715 or DIN 35 rail

Operating positions:

- . Vertical, Horizontal, Upside down, On the side

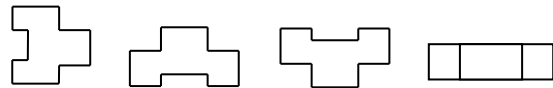

Power Supply:

- . Mandatory in 12 VDC via the specific Power supply module Cat n° 4 149 45
- . Two ways:
 - via specific communication patch cords (cat. nos 4 149 07/08/09) to connect at the downstream through dedicated ports



- via specific communication rails (cat. nos 4 149 01/02/03) to connect at the rear through dedicated connectors

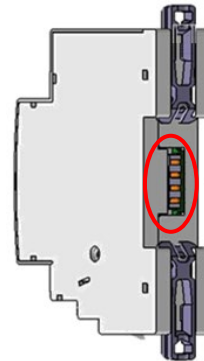

EMS CX³ - Pulse concentrator module

Cat. N° : 4 149 26

4. PREPARATION –CONNECTION (continued)

Terminals:

- . Terminal depth: 8 mm.
- . Stripping length: 8 mm

Screw head:

- . Mixed, slotted and Pozidriv n° 1 (UNI7596 type Z1).

Recommended tightening torque:

- . 1 Nm.

Recommended tools:

- . For the terminals: Pozidriv n° 1 or flat screwdriver 4 mm.
- . For fixing: flat screwdriver 5.5 mm (6 mm maximum).

Conductor type:

	Copper cable	
	Without ferrule	With ferrule
Rigid Cable	1 x 0,5 mm ² to 1,5 mm ² 2 x 1,5 mm ²	-
Flexible Cable	1 x 0,5 mm ² to 1,5 mm ² 2 x 1,5 mm ²	1 x 0,5 mm ² to 1,5 mm ² 2 x 1,5 mm ²

Wiring diagrams:

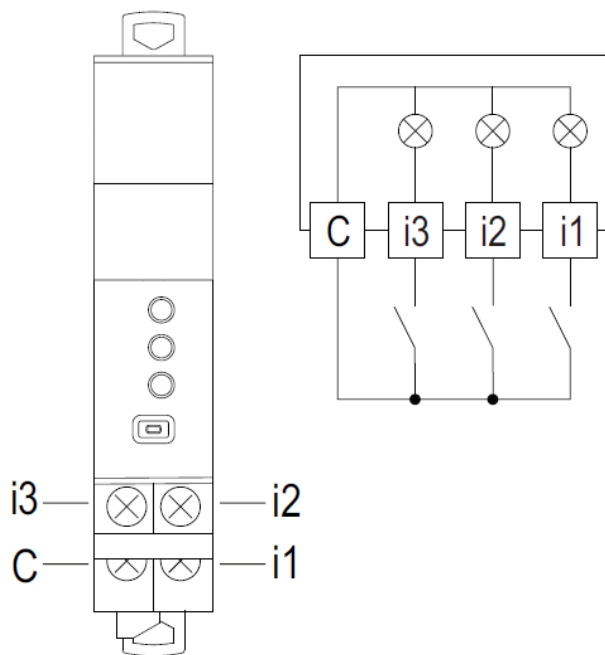

Note:

- . Inputs from voltage-free SPST NO contacts
- . Cable length: max. 1000 m
- . Resistance of the circuit: $R_{max} \leq 125 \Omega @ 25^\circ C$

4. PREPARATION –CONNECTION (continued)

Data connection (EMS CX³ modules inter-connection):

- . Via specific communication patch cords (cat. nos 4 149 07/08/09)



Allow data transmission between the different EMS CX³ modules. This type of connection is recommended when there are few EMS CX³ modules, distributed all over the enclosure.

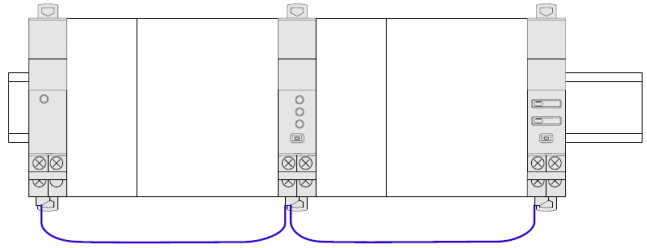

Implementing: with this configuration, the plastic protection cover of the backside communication ports on the EMS CX³ module must be keep on.

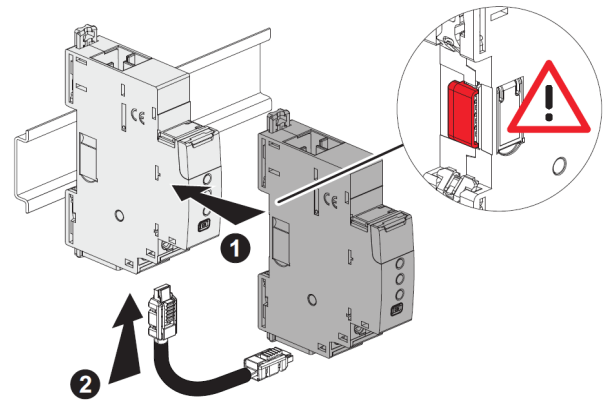

EMS CX³ - Pulse concentrator module

Cat. N° : 4 149 26

4. PREPARATION –CONNECTION (continued)

Data connection (EMS CX³ modules inter-connection)

(continued):

. Via specific communication rails (cat. nos 4 149 01/02/03).



. Allow data transmission between the different EMS CX³ modules.

This type of connection is recommended when there are several EMS CX³ modules on the same DIN row.

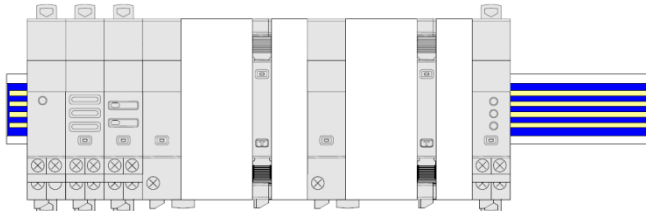

Implementing: with this configuration, the plastic protection cover of the backside communication ports on the EMS CX³ module must be removed.

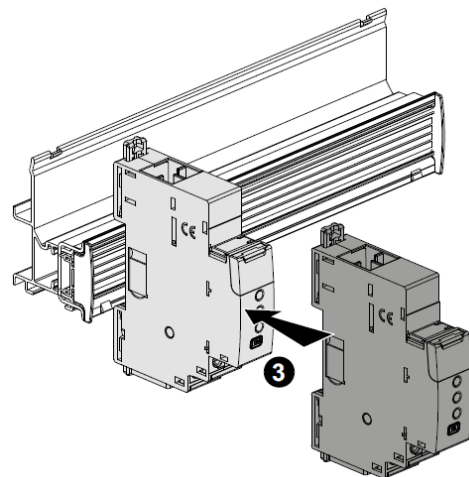
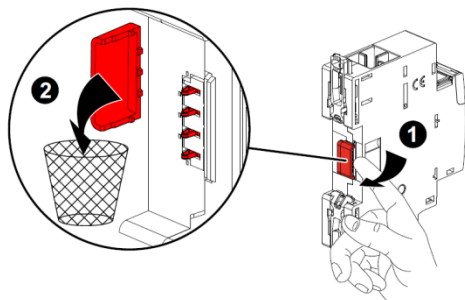

Note: Sliding the form to the right or left is prohibited.

4. PREPARATION –CONNECTION (continued)

Data connection (EMS CX³ modules inter-connection)

(continued):

. Via a mix between specific communication patch cords and communication rails in order to create a link between several rows

Two situations:

- Individually connected with communication rails.
The communication patch cord allows to connect two rows.



- Individually connected with communication patch cords & communication rail.
The communication patch cords allow to connect EMS CX³ module on a row and to connect two rows.

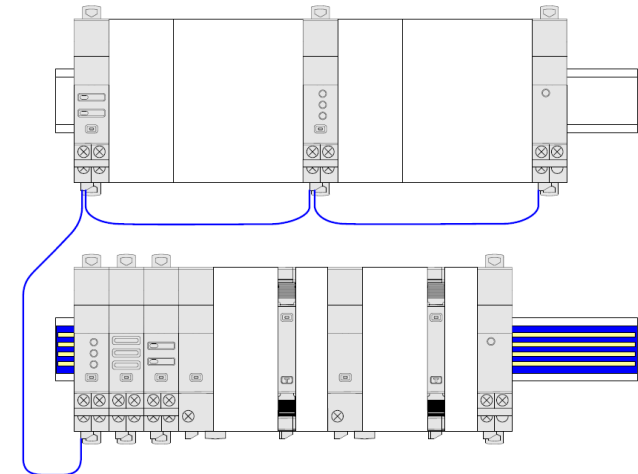

EMS CX³ - Pulse concentrator module

Cat. N° : 4 149 26

4. PREPARATION –CONNECTION *(continued)*

Position in a row:

. The product profile and the position of the terminals at the downstream allow the insertion of the prong-busbar by the upstream. In this way the position of the EMS CX³ device in a row can be freely chosen

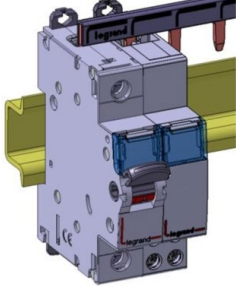

Module maintenance:

. A device may be replaced in the middle of a row supplied with prong-busbar without disconnecting the other devices.

1. Put the clamp in the unlocking position

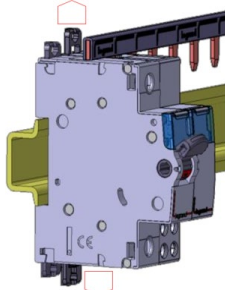

1. Put the clamp in the unlocking position

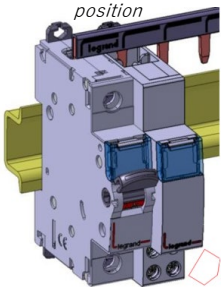

2. Pull the device forward in order to release it from the rail

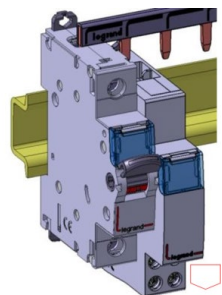

3. Pull the device downward in order to release it completely from the prongs of the busbar

Labelling:

. Circuit identification by way of a label inserted in the label holder situated on the front of the product.

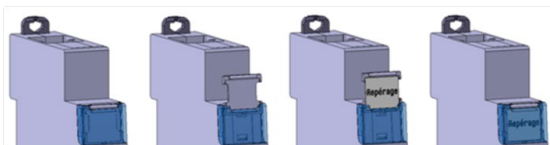

5. GENERAL CHARACTERISTICS

Front face marking:

. By permanent ink pad printing (red line) and laser marking

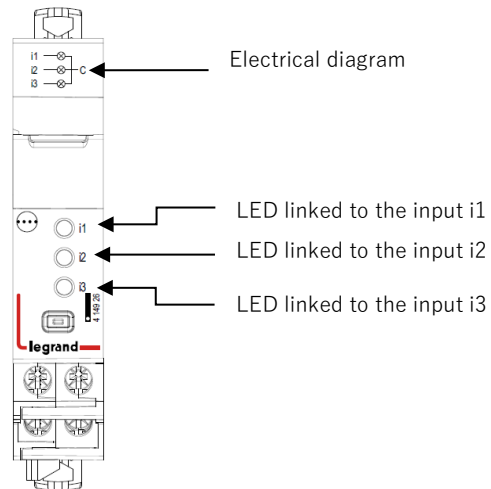

Lateral side marking:

. By laser.

left side: Standard and programming information

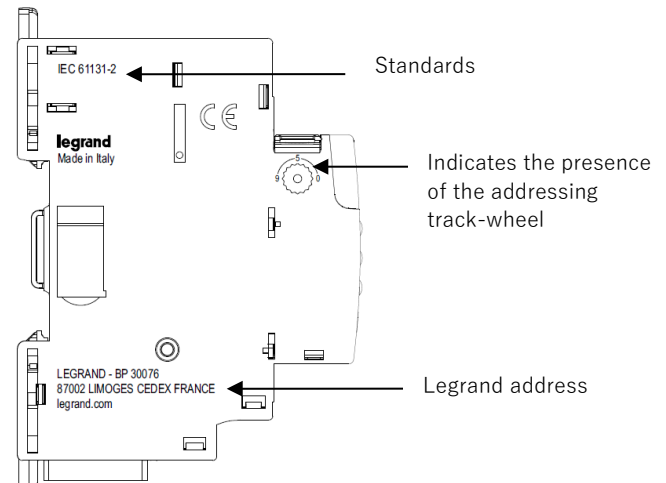

right side: cabling and traceability information

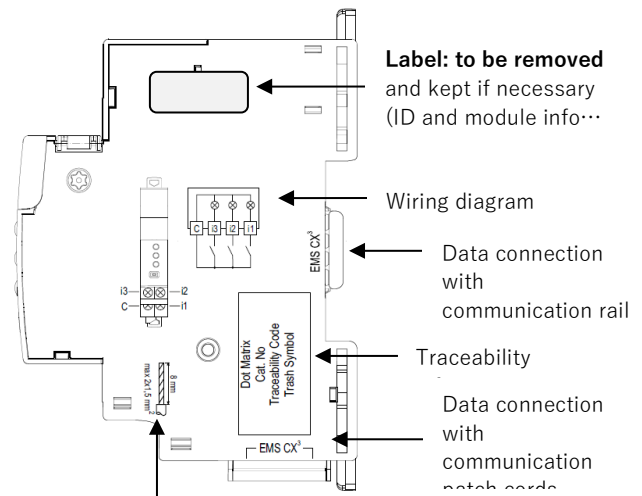

Cabling information

EMS CX³ - Pulse concentrator module

Cat. N° : 4 149 26

5. GENERAL CHARACTERISTICS *(continued)*

Measuring LEDs:

- . The device is equipped with 3 signalling LEDs indicating that the module has received a pulse in input:
- blinking red → one light pulse each impulse received

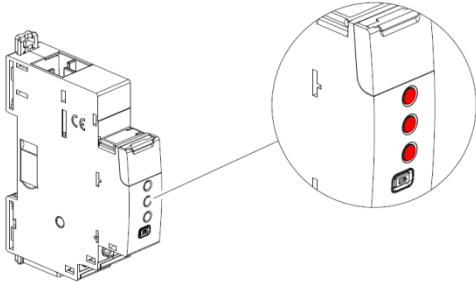

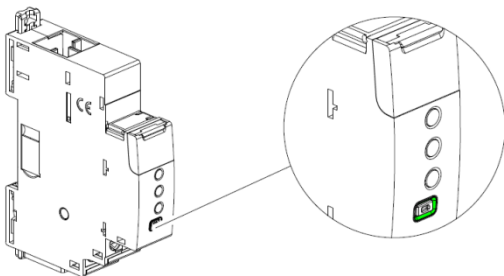

Multi-Functions button:

- . Front face button as several functions:



- . Gives information about the operating state on the module
- Possible states:

Led colour	State	Meaning
 red	Slow blinking	Error (e.g. addressing error)
	Fast blinking	No function
	Steady <i>(pressing the multifunction button longer than 10 sec.)</i>	Total reset [any firmware updates are preserved]
 green	Slow blinking	System process is running. Wait until the Led turns steady
	Fast blinking <i>(pressing the multifunction button for 5 sec.)</i>	put in "Stand-by" the EMS CX ³ module (no remote action and communication available)
	Steady	System OK, connection is running
 orange	Slow blinking	Creation of a link with "Link Functionality" procedure <i>(see next §)</i>
	Fast blinking	Device's firmware update in progress
	Steady	Start of FW update or active Link functionality (see next §)

5. GENERAL CHARACTERISTICS *(continued)*

Inputs characteristics:

- . N° of inputs: 3 passives
- . Input type: potential free SPST-NO contact
- . Connections: 3 inputs with common point
- . Input pulse waveform: ON state: ≥ 20 ms
- . Input frequency: max. 25 Hz
- . Engineering units programmable, possible values: pulses, Wh, kWh, MWh, varh, kvarh, Mvarh, VAh, kVAh, MVAh, m³, km³, Mm³, Nm³, kNm³, MNm³, J, kJ, MJ, cal, kcal, g, kg, t, L (*), dm³ (*).
- . Pulse weight programmable, possible values: from 0,01 to 32767
- (* available from the firmware version 1.5.7 (Production date indicated on the label stucked on the side of the module ≥ 21W23)

Note:

- . Default configuration for the 3 inputs: 10 Wh/imp
- . All the configuration can be made via IME - Nemo SX configurator software (download for free) or via Nemo SX Mini configurator module (cat. no SXV01)

Insulation voltage:

- . U_i = 400 V

Impulse withstand voltage U_{imp}:

- . EMS ports / Input terminals:
 - wave 1,2 / 50 μs: 6 kV
 - alternate current 50 Hz / 1 min.: 3 kV

Pollution degree:

- . 2 according to IEC/EN 60898-1.

Overvoltage category:

- . III

Dielectric strength:

- . 2500 V

Plastic material:

- . Self-extinguishing polycarbonate.
- . Heat and fire resistant according to IEC/EN 60695-2-12, glow-wire test at 960° C.
- . Classification UL 94 / IECEN 60695-11-10: V1

Ambient operating temperature:

- . Min. = -25° C. Max. = +70° C

Ambient storage temperature:

- . Min. = -40° C. Max. = +70° C

Protection Index:

- . Protection index of terminals against direct contacts: IP2X (IEC/EN 60529).
- . Protection index of terminals against solid and liquid bodies (wired device): IP 20 (IEC/EN 60529).
- . Protection index of the front face against solid and liquid bodies: IP 40 (IEC/EN 60529).
- . Class II, front panel with faceplate.

5. GENERAL CHARACTERISTICS *(continued)*

Average weight per device:

. 0,054 kg.

Volume when packed:

. 0,21 dm³.

Consumption:

. Values at 12 VDC

24,0 mA, 0,288 W

6. SYSTEM ARCHITECTURES

The EMS CX³ is a polyvalent system and, according to the needs of the customer, can be set up and/or used as "Stand-alone" or "Supervised" system. Based on this choice the configuration and addressing methods are different.

Four possible architectures are provided:

6.1 Stand-alone system

6.1.1 with local addressing (through the track wheel)

6.1.2 with remote addressing (through a computer)

6.2 Supervised (Computer Supervisory System)

6.2.1 with local addressing

6.2.2 with remote addressing

6.1 Stand-alone system

. **Stand-alone** = autonomous system. To be used by the end-user if it is not necessary to have a computer for the supervision outside the envelope. Everything can be managed on site.

6.1.1 Stand-alone system with local addressing (through the track wheel)

Local addressing advantages:

- No configuration software needed to set-up the installation
- **It is not necessary to use a computer to manage settings** (configurations, test, ...) and to use the system (visualize and be alerted, ...). Everything can be done through the Mini configuration module (local display, cat. no 4 149 36/37). [Refer to the technical sheet dedicated to this module for details].
- No communication Interfaces or gateways are required.
- Installation can be done without the intervention of a System Integrator

Programming procedure:

. For EMS CX³ modules which need some: mandatory via the configuration software (see § "Module configuration")

Addressing procedure:

. For all EMS CX³ modules: mandatory through the track wheel located on the top upper face of each EMS CX³ modules

. Marked from 0 to 9 in order to locally define the Modbus address of the EMS CX³ modules

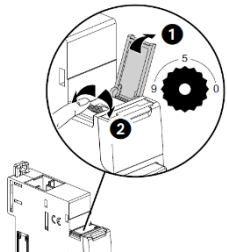

Note for Measure Module "3x single phase":

This module is to be consider as 3 modules with 3 different Modbus Address. The module takes automatically the two addresses immediately following to the programmed one (e.g. Programmed address = 2, Addresses of the module 2, 3, 4)

Consequences of the local addressing mode (through the track wheel):

- . Each device of the system must be addressed.
- . Addresses available: from 1 to 9
- . Address 0 not permitted
- . It is possible to assign to several devices the same address with the purpose of grouping different functions, **because they are related to the same electrical circuit**. For example, it is possible to assign the same address to a signalling auxiliary module (cat. no 4 149 29), a universal control module (cat. no 4 149 32), a measuring module, and so on. In this way on the EMS CX³ mini configuration module (local display) the grouped function will be displayed as a unique "device" with all grouped functions. [Refer to the schemes hereunder]

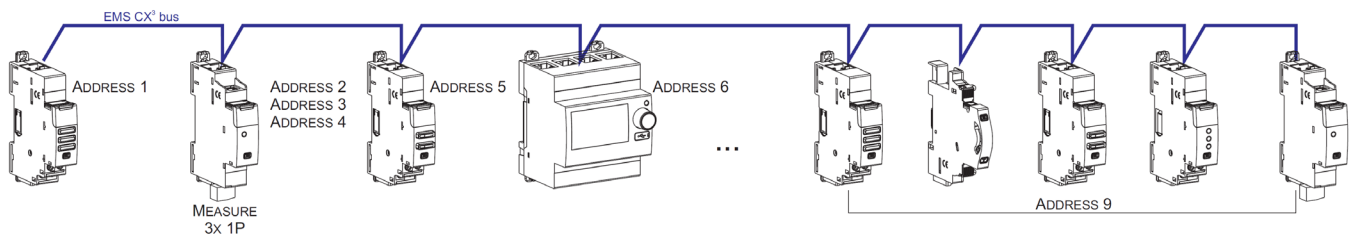

Note for the mini configuration module (local display)

- . It is possible to assign it the same address as another EMS CX³ through the programming menu of the device
- . The mini configuration module can be placed everywhere in the EMS CX³ bus

6. SYSTEM ARCHITECTURES

6.1 Stand-alone system *(continued)*

6.1.2 Stand-alone system with remote addressing (through a computer)

Remote addressing advantages:

- Whole configuration (addresses and functions) can be set up through the EMS Configuration software
- Configuration software available for free
- **Automatic detection of the EMS CX³ modules** installed in the system (characteristics, functions, configuration...)
- **Increased settings possibilities: load shedding function**
- Increased addressing: **up to 30 Modbus addresses in a system**

Programming procedure:

. For EMS CX³ modules which need some: mandatory via the configuration software *(see § "Module configuration")*

Addressing procedure:

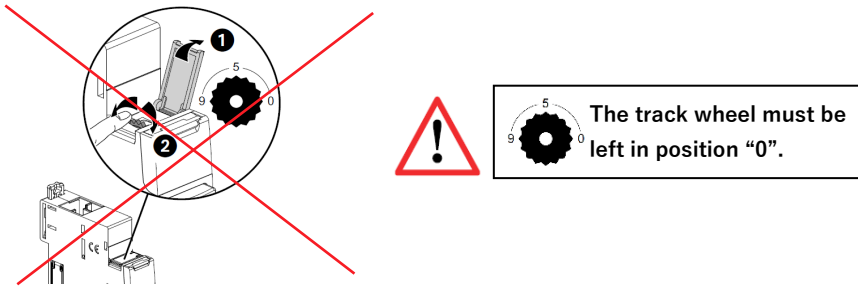

. It is not necessary to address the EMS CX³ modules. **The track wheel must be left in default position "0".**

. All the addressing/configuring procedure will be done with the Configuration Software (available online for free)

. With remote addressing, the software does the automatic detection of modules installed in the system, but the supervision is not possible until the user assigns the remote address and all the characteristics to each module.

Note: it is mandatory to connect the computer to the Mini configuration module with an USB-micro USB cable. *[For more details, refer to the technical data sheet of the Mini configuration module EMS CX²]*

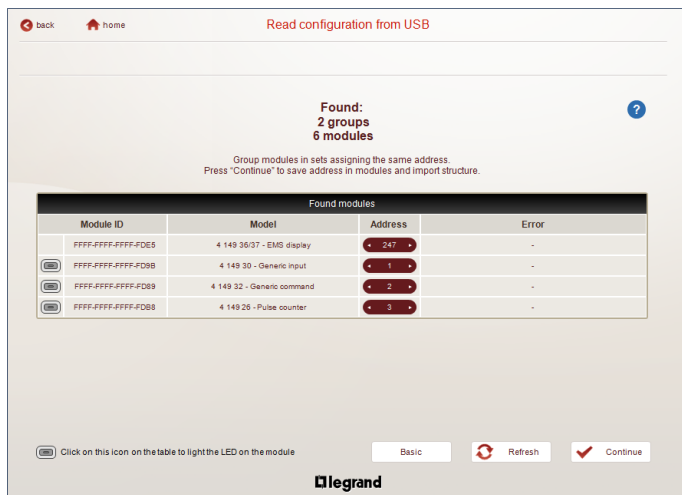
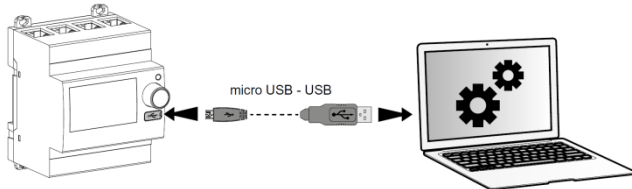

Note for Measure Module "3x single phase":

This module is to be consider as 3 modules with 3 different Modbus Address. The module takes automatically the two addresses immediately following to the programmed one (e.g. Programmed address = 2, Addresses of the module 2, 3, 4)

6. SYSTEM ARCHITECTURES

6.1 Stand-alone system *(continued)*

6.1.2 Stand-alone system with remote addressing (through a computer) *(continued)*

Consequences for the system architecture:

- for 1 mini configuration module (cat. no 4 149 36/37)
 - o up to **30 EMS CX³ modules** (e.g. 30 devices grouped per functions with addresses from 1 to 30)

It is possible to assign to several devices the same address with the purpose of grouping different functions, **because they are related to the same electrical circuit**. For example, it is possible to assign the same address to a signalling auxiliary module (cat. no 4 149 29), a universal control module (cat. no 4 149 32), a measuring module, and so on. In this way on the EMS CX³ display or in a supervision system the grouped function will be displayed as a unique "device" with all grouped functions. *[Refer to the schemes here under]*

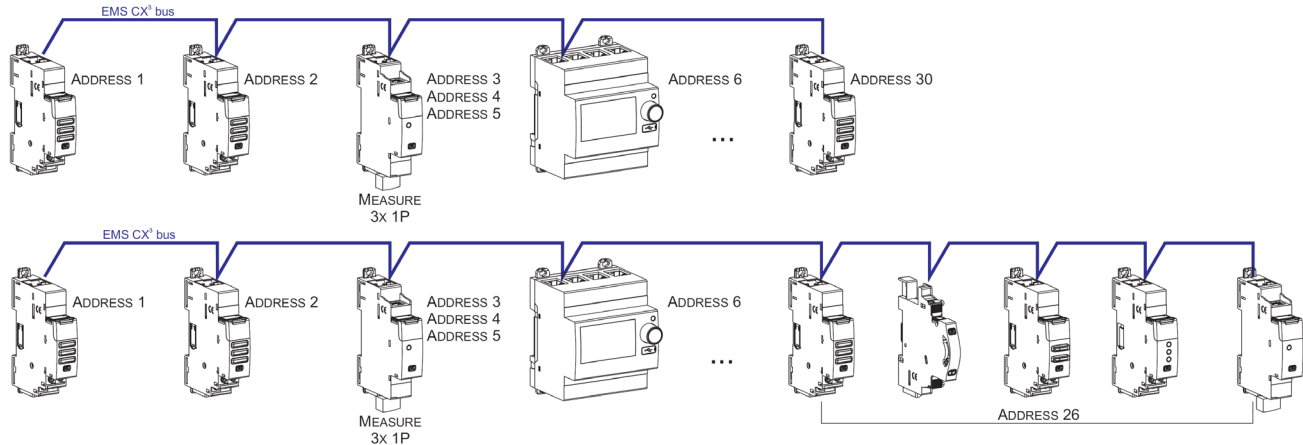

- . It is possible to assign it the same address as another EMS CX³
- . The mini configuration module can be placed everywhere in the EMS CX³ bus

6.2 Supervised system (Computer Supervisory System)

. **Supervised system** = System to be used through a Computer Supervisory System to remotely read data from the EMS CX³ devices and/or do operations on these devices (e.g. commands of a motor driven or contactor ...).

6.2.1 Supervised system with local addressing (through the track wheel)

Local addressing advantages:

- No configuration software needed to set-up the installation
- Installation can be done without the intervention of a System Integrator

Programming procedure:

. For EMS CX³ modules which need some: mandatory via the configuration software *(see § "Module configuration")*

Addressing procedure:

. For all EMS CX³ modules: mandatory through the track wheel located on the top upper face of each EMS CX³ modules

. Marked from 0 to 9 in order to locally define the Modbus address to EMS CX³ modules
 In this system the Modbus address of an EMS CX³ module device or group of modules (several functions) is obtained considering the address of the interface Modbus/EMS CX³ Interface as tenth and the address of a device or group of function as unit (e.g. Interface address 1 = 10 → address of module n° 5 = Modbus address 15)

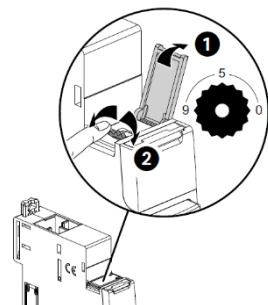

Note for Measure Module "3x single phase":

This module is to be consider as 3 modules with 3 different Modbus Address. The module takes automatically the two addresses immediately following to the programmed one (e.g. Programmed address = 12, Addresses of the module 12, 13, 14)

6. SYSTEM ARCHITECTURES *(continued)*

6.2 Supervised system (Computer Supervisory System) *(continued)*

6.2.1 Supervised system-with local addressing (through the track wheel) *(continued)*

Consequences of the local addressing mode (through the track wheel):

- . Each device of the system must be addressed.
- . Rotary position available: from 1 to 9
- . Rotary position in 0 not permitted

It is possible to assign to several devices the same address with the purpose of grouping different functions, **because they are related to the same electrical circuit**. For example, it is possible to assign the same address to a signalling auxiliary module (cat. no 4 149 29), a universal control module (cat. no 4 149 32), a measuring module, and so on. In this way on the EMS CX³ display or in a supervision system the grouped function will be displayed as a unique “device” with all grouped functions. *[Refer to the scheme hereunder]*

Note: In this configuration the Modbus address of an EMS CX³ module device or group of modules (several functions) is obtained considering the address of the interface Modbus/EMS CX³ Interface as tenth and the address of a device or group of function as unit (e.g. Interface rotary 1 = 10 and device rotary = 5 → Modbus address = 15)

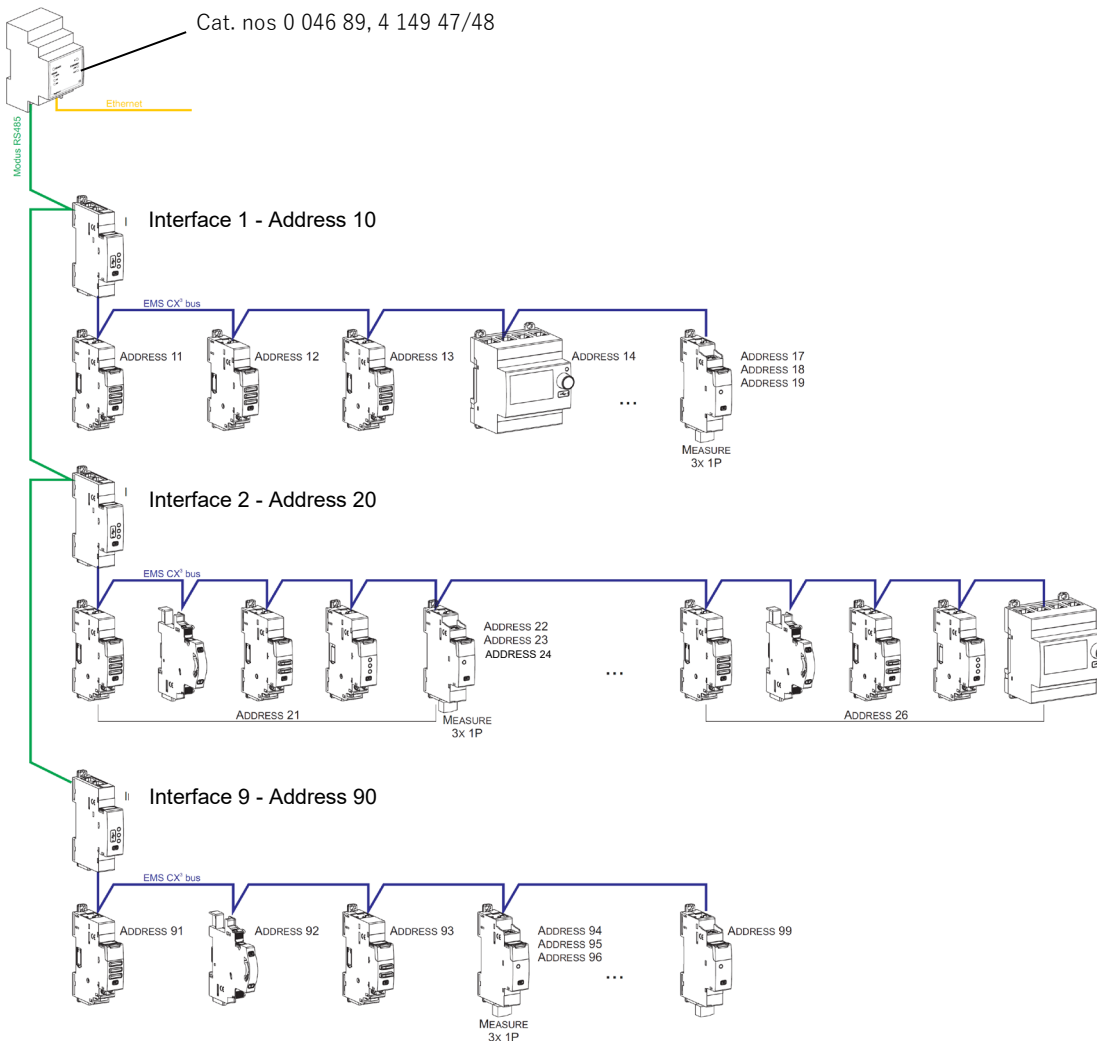

Consequences for the system architecture:

- for 1 IP/Modbus gateway (cat. no 0 046 89):
 - o up to **81 Modbus address**
 - o mandatory limit of max. **9 Modbus/EMS CX³ interfaces** or max. **1000 m of Modbus cable** (cable Belden 9842, Belden 3106A or equivalent) or max. **50 m of Category 6 cable** (FTP or UTP).
- for 1 Modbus/EMS CX³ Interface (cat. no 4 149 40):
 - o up to **30 EMS CX³ modules** (ex. 30 devices grouped per functions with addresses from 1 to 9)

Note: with local addressing, the Modbus/EMS CX³ interface, does the automatic detection of modules (characteristics, functions, configuration...)

6. SYSTEM ARCHITECTURES *(continued)*

6.2 Supervised system (Computer Supervisory System) *(continued)*

6.2.2 Supervised system-with remote addressing (through a computer)

Remote addressing advantages:

- Whole of configuration (addresses and functions) can be done a remotely through the EMS Configuration software
- Configuration software available for free
- **Automatic detection of the EMS CX³ modules** installed in the system (characteristics, functions, configuration...)
- **Increased settings possibilities: load shedding function**
- Increased addressing: **up to 32 Modbus/EMS CX³ interfaces**
- Increased addressing: **up to 247 Modbus addresses in a system**

Programming procedure:

. For EMS CX³ modules which need some: mandatory via the configuration software *(see § "Module configuration")*

Addressing procedure:

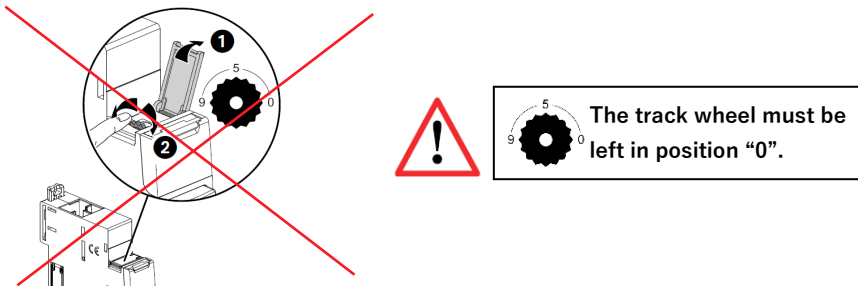

. It is not necessary to address the EMS CX³ modules. **The track wheel must be left in default position "0".**

. All the addressing/configuring procedure will be done with the Configuration Software (available online for free)

. With remote addressing, the software does the automatic detection of modules installed in the system, but the supervision is not possible until the user assigns the remote address and all the characteristics to each module.

Note: it is mandatory to connect the computer to the different Modbus/EMS CX³ interface with an USB-micro USB cable (one interface at a time). *[For more details, refer to the technical data sheet of the Modbus/EMS CX⁶ interface]*

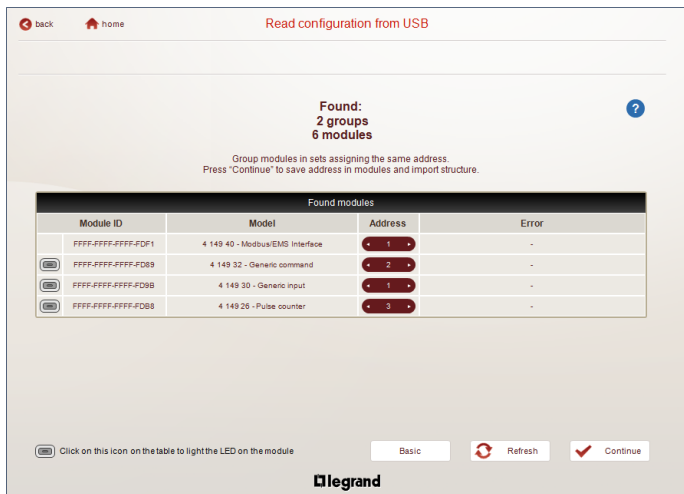
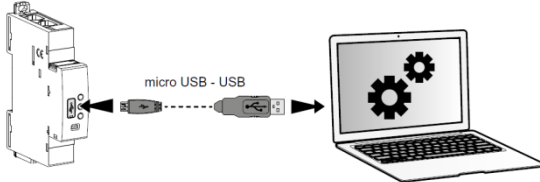

Note for Measure Module "3x single phase":

This module is to be consider as 3 modules with 3 different Modbus Address. The module takes automatically the two addresses immediately following to the programmed one (e.g. Programmed address = 2, Addresses of the module 2, 3, 4)

6. SYSTEM ARCHITECTURES *(continued)*

6.2 Supervised system (Computer Supervisory System) *(continued)*

6.2.2 Supervised system-with remote addressing (through a computer) *(continued)*

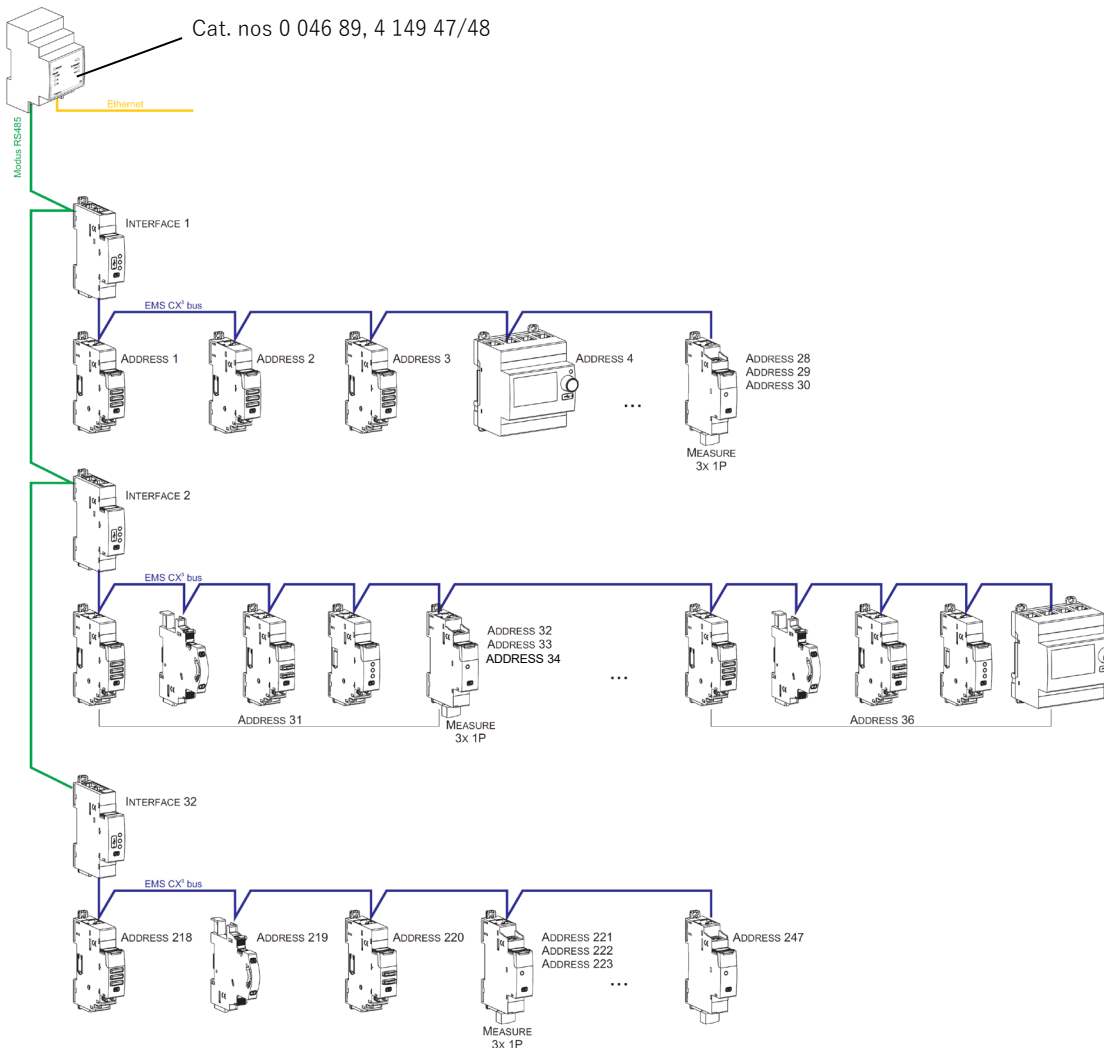

Consequences for the system architecture:

- for 1 IP/Modbus gateway (cat. no 0 046 89):
 - o up to **247 Modbus address**
 - o Because of Modbus: mandatory limit of max. **32 Modbus/EMS CX³ interfaces** or max. **1000 m of Modbus cable** (cable Belden 9842, Belden 3106A or equivalent) or max. **50 m of Category 6 cable** (FTP or UTP).
- for 1 Modbus/EMS CX³ Interface (cat. no 4 149 40):
 - o up to **30 EMS CX³ modules or grouped modules** (e.g. 30 devices grouped per functions with addresses from 1 to 30)

It is possible to assign to several devices the same address with the purpose of grouping different functions, **because they are related to the same electrical circuit**. For example, it is possible to assign the same address to a signalling auxiliary module (cat. no 4 149 29), a universal control module (cat. no 4 149 32), a measuring module, and so on. In this way on the EMS CX³ display or in a supervision system the grouped function will be displayed as a unique "device" with all grouped functions. *[Refer to the scheme up here]*

7. COMPLIANCE AND APPROVALS

Compliance to standards:

- . Compliance with Directive on electromagnetic compatibility (EMC) n° 2014/30/EU
- . Compliance with low voltage directive n° 2014/35/EU.
- . Electromagnetic Compatibility: IEC/EN 61131-2
- . Product standard: IEC/EN62053-31 class B (Annex D)

Environment respect - Compliance with EU directives:

- . Compliance with Directive 2011/65/EU as amended by Directive 2015/863 (RoHS 2) on the restriction of the use of certain hazardous substances in electrical and electronic equipment.
- . Compliance with REACH regulation (1907/2006): at the date of the publication of this document no element of the SVHC substance list (updated on 27/06/2018) is present in these products.
- . WEEE directive (2012/19/EU): the sale of this product is subject to a contribution to eco-organisations in each country responsible for managing end-of-life products in the field of application of the European Waste Electronic and Electrical Equipment Directive.

Plastic materials:

- . Halogens-free plastic materials.
- . Marking of parts according to ISO 11469 and ISO 1043.

Packaging:

- . Design and manufacture of packaging compliant to decree 98-638 of the 20/07/98 and also to directive 94/62/CE.

Environmental profile:

- . PEP document available

Installation software:

- . XL PRO³.