

# EMS CX<sup>3</sup> – Multifunction Measuring module with closed Rogowski coils

Cat. Nos: 4 149 15/16/18/19/20/21

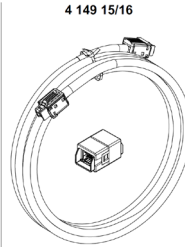
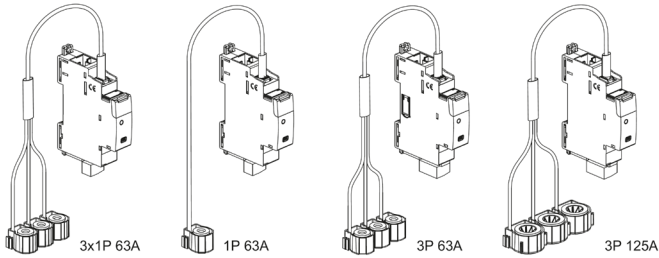

Contents	Pages
1. Description - Use .....	1
2. Range .....	1
3. Overall dimensions.....	2
4. Preparation - Connection .....	3
5. General characteristics .....	8
6. System architectures.....	13
6.1 Stand-alone.....	13
6.1.1 with local addressing.....	13
6.1.2 with remote addressing.....	14
6.2 Supervised.....	15
6.2.1 with local addressing.....	15
6.2.2 with remote addressing.....	17
7. Compliance and approvals .....	19

## 1. DESCRIPTION - USE

. Module dedicated to Energy Management System (EMS CX<sup>3</sup>) use.  
Multifunction Measuring module.  
Measures the main electrical data of a single-phase or three-phase network.  
The insertion is done by closed Rogowski coils.

### Symbol:



## 2. RANGE

- . Cat. n° 4 149 18: Multifunction measuring module (1 module. 17,8 mm width) delivered with non-interchangeable coil to measure three single-phase circuits up to 63 A at once
- . Cat. n° 4 149 19: Multifunction measuring module (1 module. 17,8 mm width) delivered with non-interchangeable coil to measure a single-phase circuit up to 63 A
- . Cat. n° 4 149 20: Multifunction measuring module (1 module. 17,8 mm width) delivered with non-interchangeable coils to measure a three-phase circuit up to 63 A
- . Cat. n° 4 149 21: Multifunction measuring module (1 module. 17,8 mm width) delivered with non-interchangeable coils to measure a three-phase circuit up to 125 A

## 2. RANGE (continued)

- . Cat. n° 4 149 15: kit consisting of n° 1 Rogowski coils extension cable of 1000 mm length + n° 1 Extension connector.
  - . Cat. n° 414916: kit consisting of n° 1 Rogowski coils extension cable of 3000 mm length + n° 1 Extension connector.  
Allow to increase the length of Rogowski coils cable: cords are clipped to either side of the connector.
- Maximum total allowed length: 3,35 meters (Rogowski coils cable: 0,35 m; extension cable: 3 m).**

### Rated current:

- . Cat. nos 4 149 18/19/20:
  - Min current, I<sub>min</sub>: 1 A
  - Base current, I<sub>b</sub>: 20 A
  - Max current, I<sub>max</sub>: 63 A
- . Cat. No 4 149 21:
  - Min current, I<sub>min</sub>: 2 A
  - Base current, I<sub>b</sub>: 40 A
  - Max current, I<sub>max</sub>: 125 A

### Insertion rated voltages:

- . Un: 110 ÷ 500 V~ (phase/phase)
- . Un: 65 ÷ 290 V~ (phase/neutral)

### Rated frequency:

- . fn: 50/60 Hz
- . Admitted variation:
  - 45 ÷ 55 Hz (fn 50 Hz)
  - 55 ÷ 65 Hz (fn 65 Hz)

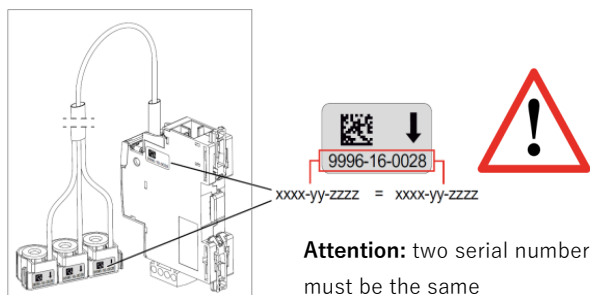

### 3. OVERALL DIMENSIONS

. 4 149 18:  
Module

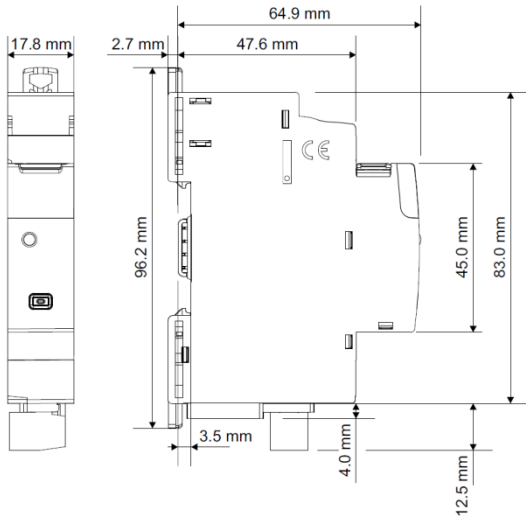

Rogowski coil

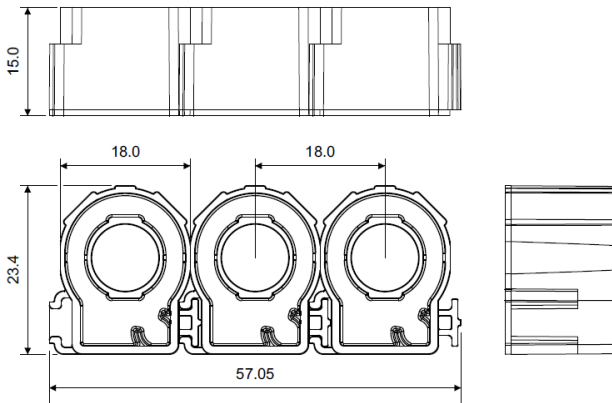

. 4 149 19:  
Module

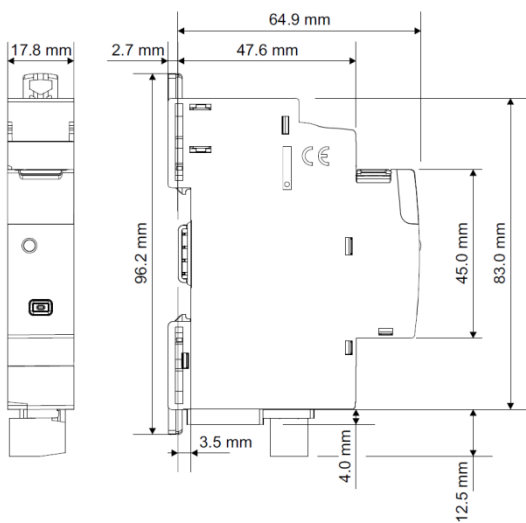

### 3. OVERALL DIMENSIONS (continued)

. 4 149 19 (continued):  
Rogowski coil

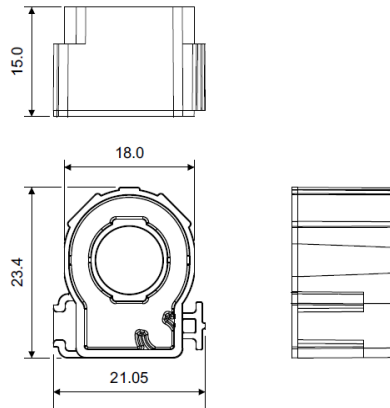

. 4 149 20:  
Module

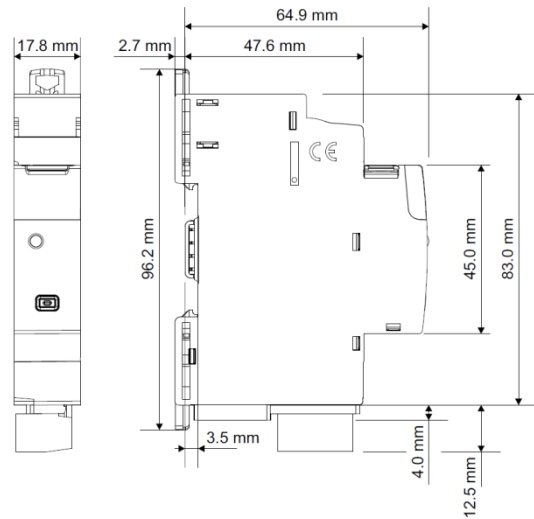

Rogowski coil

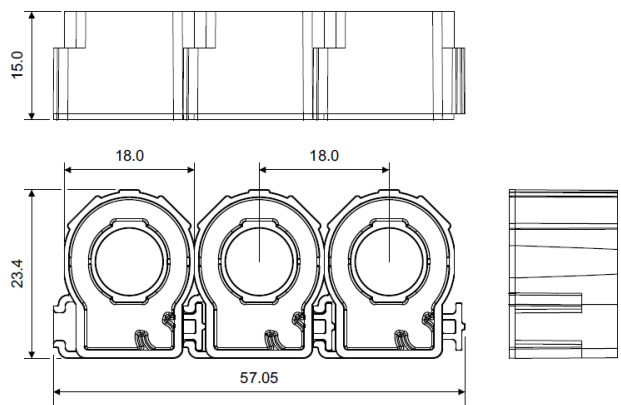

**Note:**

- . Pitch between two sensors is 18.0 mm
- . Sensors can be simply separated in order to be associated to modular devices 1,5 modules per pole width or to non-modular power devices (e.g. MCCB's)

# EMS CX<sup>3</sup> - Multifunction Measuring module with closed Rogowski coils

Cat. Nos: 4 149 15/16/18/19/20/21

## 3. OVERALL DIMENSIONS *(continued)*

. 4 149 21:  
Module

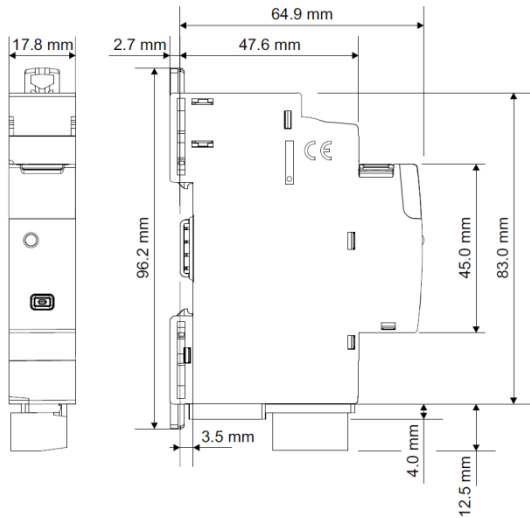

Rogowski coil

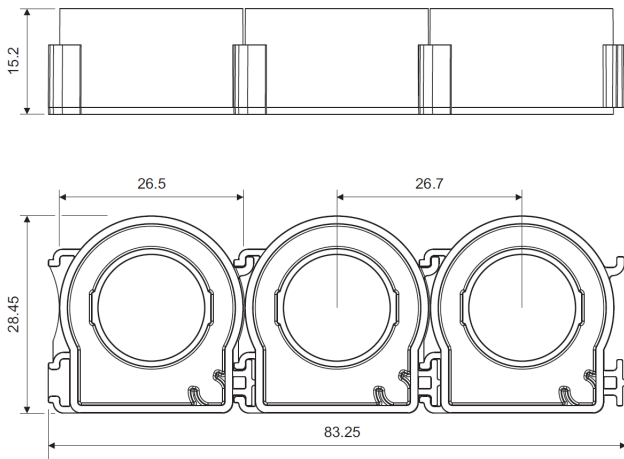

### Note:

- . Pitch between two sensors is 26,7 mm
- . Sensors can be simply separated in order to be associated to non-modular power devices (e.g. MCCB's)

### Rogowski sensor(s) - Cable length

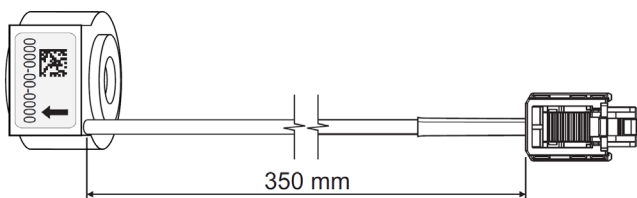

This length can be stretched via the Extension cable + connector up to 3,35 meters (0,35 m of Rogowski cable and up to 3 m of extension)

## 4. PREPARATION -CONNECTION

### Fixing:

- . On symmetric rail EN/IEC 60715 or DIN 35 rail

### Operating positions:

- . Vertical, Horizontal, Upside down, On the side

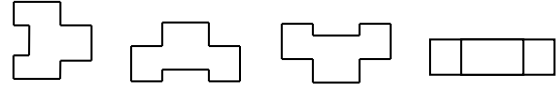

### Power Supply:

- . Mandatory in 12 VDC via the specific Power supply module Cat n° 4 149 45
- . Two ways:
  - via specific communication patch cords (cat. nos 4 149 07/08/09) to connect at the downstream through on dedicated ports

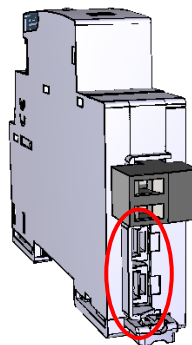

- via specific communication rails (cat. nos 4 149 01/02/03) to connect at the rear through dedicated connectors

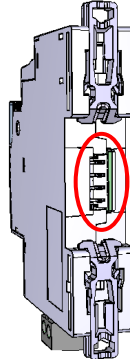

### Voltage terminals:

- The removable black terminal is used to connect voltage(s)
- . Terminal depth: 8 mm.
- . Stripping length: 8 mm

### Screw head:

- . Screw slotted.

### Recommended tightening torque:

- . 0,5 Nm.

### Recommended tools:

- . For the terminals: flat screwdriver 3,5 mm.
- . For fixing: flat screwdriver 5.5 mm (6 mm maximum).

# EMS CX<sup>3</sup> - Multifunction Measuring module with closed Rogowski coils

Cat. Nos: 4 149 15/16/18/19/20/21

## 4. PREPARATION –CONNECTION (continued)

### Connectable section:

. Copper cables.

Voltage measurement terminals

	Without ferrule	With ferrule
Rigid Cable	1 x 0,5 mm <sup>2</sup> to 2,5 mm <sup>2</sup> 2 x 1,5 mm <sup>2</sup>	-
Flexible Cable	1 x 0,5 mm <sup>2</sup> to 2,5 mm <sup>2</sup> 2 x 1,5 mm <sup>2</sup>	1 x 0,5 mm <sup>2</sup> to 2,5 mm <sup>2</sup> 2 x 1,5 mm <sup>2</sup>

. 63 A Current Rogowski coil(s) (4 149 18/19/20)

	With internal plastic support	Without internal plastic support
Rigid Cable	1 x 1,5 mm <sup>2</sup> to 16 mm <sup>2</sup> ø 4,8 mm	1 x 1,5 mm <sup>2</sup> to 25 mm <sup>2</sup> ø 9,3 mm
Flexible Cable	1 x 1,5 mm <sup>2</sup> to 10 mm <sup>2</sup> ø 4,8 mm	1 x 1,5 mm <sup>2</sup> to 16 mm <sup>2</sup> ø 9,3 mm

. 125 A Current Rogowski coil(s) (4 149 21)

	With internal plastic support	Without internal plastic support
Rigid Cable	1 x 25 mm <sup>2</sup> to 70 mm <sup>2</sup> ø 6,4 - 12,4 mm	1 x max. 70 mm <sup>2</sup> ø 15,3 mm
Flexible Cable	1 x 16 mm <sup>2</sup> to 50 mm <sup>2</sup> ø 6,4 - 12,4 mm	1 x max. 50 mm <sup>2</sup> ø 15,3 mm

## 4. PREPARATION –CONNECTION (continued)

### Wiring diagrams:

#### Note:

. Rogowski coils can be positioned both upstream or downstream the associated protection device of the measured line.

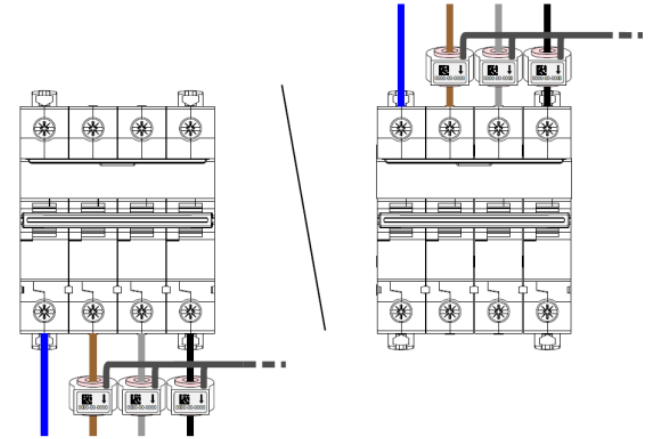

. Rogowski coils must be put in the correct direction of current flow (**arrow drawing on the coil**).

However, the direction of current flow can be, if necessary, changed via EMS CX<sup>3</sup> Configuration software or via Mini configuration module (cat. nos 4 149 36/37).

. 4 149 18

single phase network (3 x 1N-1E):

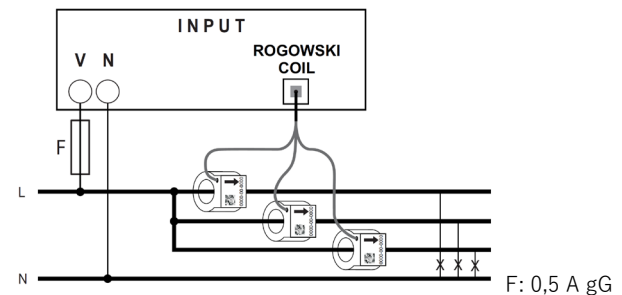

**Note: the 3 single-phase circuits measured must come from the same phase.**

. 4 149 19

single phase network (1N-1E):

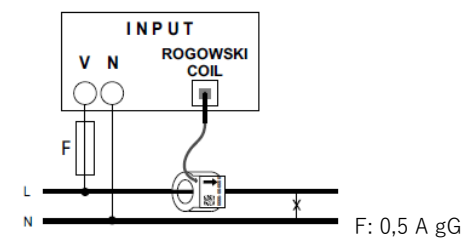

# EMS CX<sup>3</sup> - Multifunction Measuring module with closed Rogowski coils

Cat. Nos: 4 149 15/16/18/19/20/21

## 4. PREPARATION –CONNECTION (continued)

### Wiring diagrams (continued):

. 4 149 20/21

3 wires three-phase network, 3 sensors (3-3E):

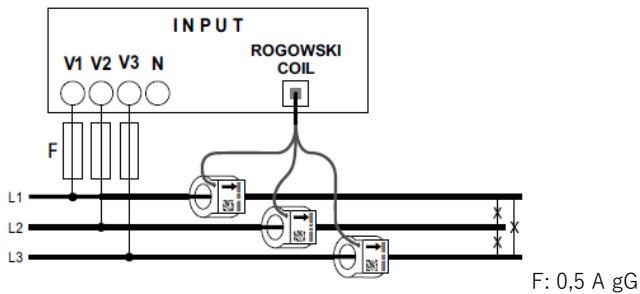

4 wires three-phase network, 3 sensors (3N-3E):

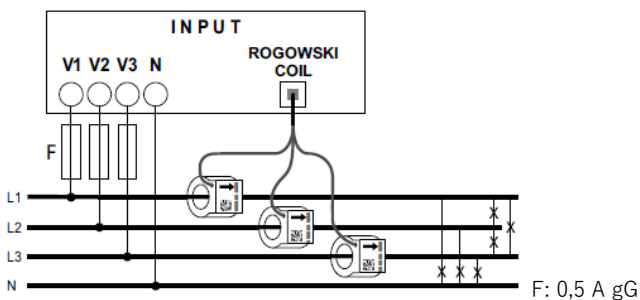

. Rogowski coil(s) cable length (see § Overall Dimensions) allow you to put EMS CX<sup>3</sup> Measure modules everywhere in the installation. This is not mandatory to have them near to the associated protection device of the measured line.

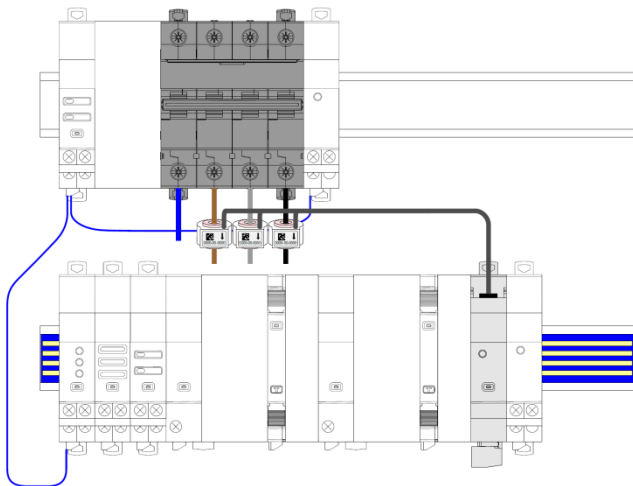

## 4. PREPARATION –CONNECTION (continued)

### Use of Extension kit:

Cords are to be clipped to either side of the connector.

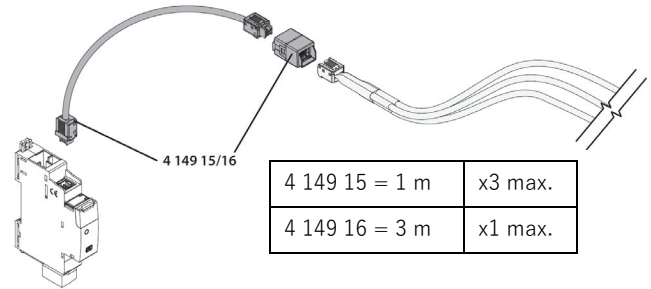

### Module configuration:

. For these devices, following configurations are available:

4 149 18/19:

- current versus

4 149 20/21:

- current versus

- insertion type (network with or without neutral conductor) [see § wiring diagrams]

. Configurations are made by EMS CX<sup>3</sup> configuration software or by the EMS CX<sup>3</sup> Mini configurator module (cat nos 4 149 36/37)

### Data connection (EMS CX<sup>3</sup> modules inter-connection):

. Via specific communication patch cords (cat. nos 4 149 07/08/09)



Allow data transmission between the different EMS CX<sup>3</sup> modules. This type of connection is recommended when there are few EMS CX<sup>3</sup> modules, distributed all over the enclosure.

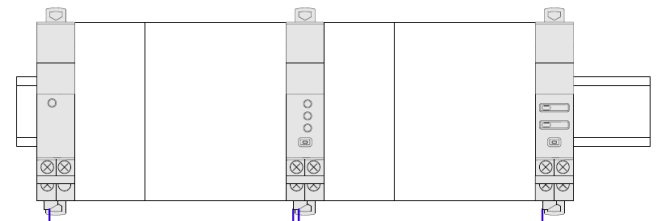

**Implementing:** with this configuration, the plastic protection cover of the backside communication ports on the EMS CX<sup>3</sup> module must be keep on.

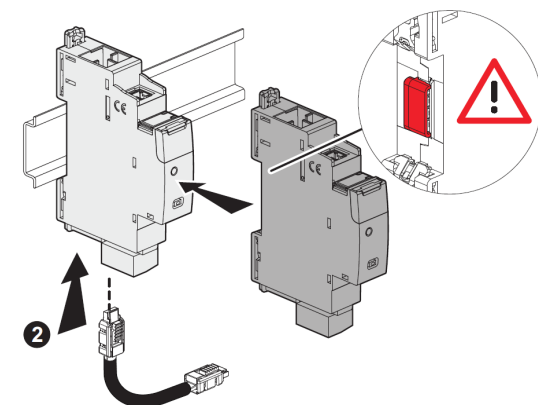

# EMS CX<sup>3</sup> - Multifunction Measuring module with closed Rogowski coils

Cat. Nos: 4 149 15/16/18/19/20/21

## 4. PREPARATION –CONNECTION (continued)

### Data connection (EMS CX<sup>3</sup> modules inter-connection)

(continued):

. Via specific communication rails (cat. nos 4 149 01/02/03).



. Allow data transmission between the different EMS CX<sup>3</sup> modules.

This type of connection is recommended when there are several EMS CX<sup>3</sup> modules on the same DIN row.

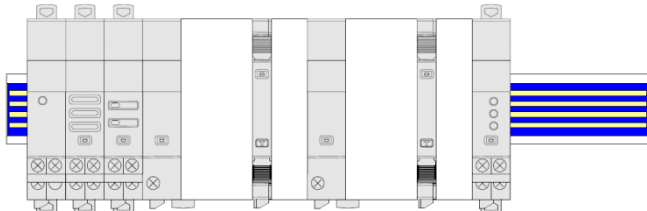

**Implementing:** with this configuration, the plastic protection cover of the backside communication ports on the EMS CX<sup>3</sup> module must be removed.

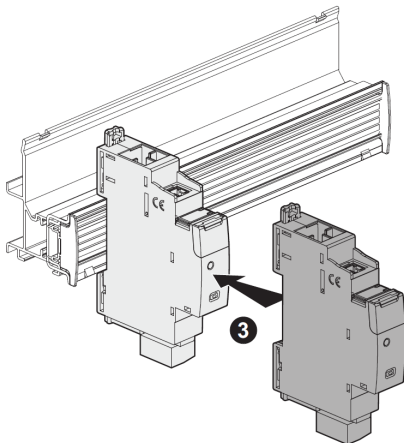
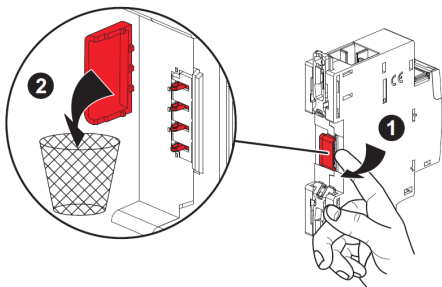

**Note:** Sliding the form to the right or left is prohibited.

## 4. PREPARATION –CONNECTION (continued)

### Data connection (EMS CX<sup>3</sup> modules inter-connection)

(continued):

. Via a mix between specific communication patch cords and communication rails in order to create a link between several rows

Two situations:

- Individually connected with communication rails.  
The communication patch cord allows to connect two rows.



- Individually connected with communication patch cords & communication rail.  
The communication patch cords allow to connect EMS CX<sup>3</sup> modules on a row and to connect two rows.

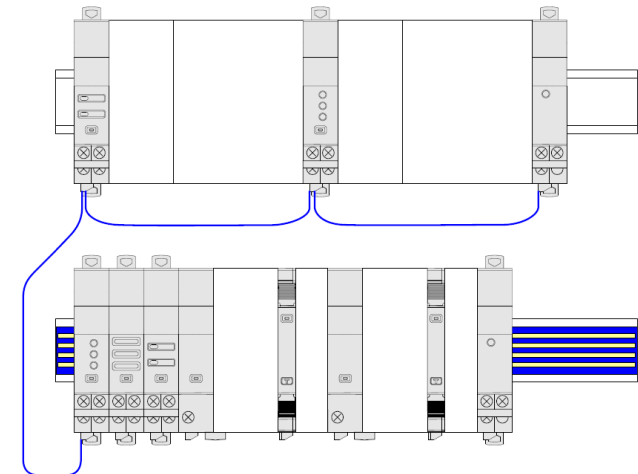

### Labelling:

. Circuit identification by way of a label inserted in the label holder situated on the front of the product.

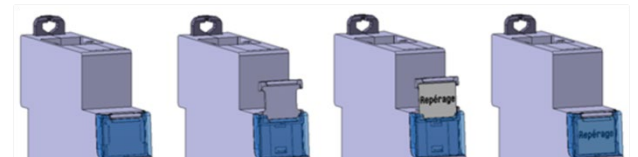

## 4. PREPARATION –CONNECTION *(continued)*

### Position in a row:

. The product profile and the position of the terminals at the downstream allow the insertion of the prong-busbar by the upstream. In this way the position of the EMS CX<sup>3</sup> device in a row can be freely chosen

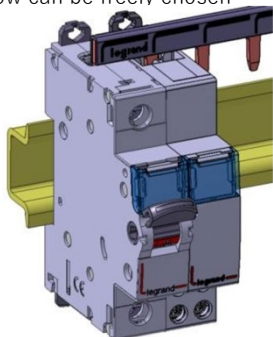

### Module maintenance:

. A device may be replaced in the middle of a row supplied with prong-busbar without disconnecting the other devices.

**1.** Put the clamp in the unlocking position

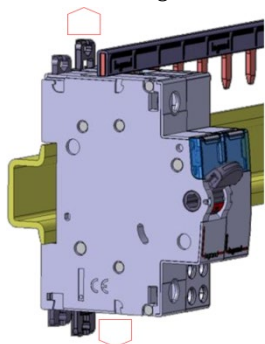

**1.** Put the clamp in the unlocking position

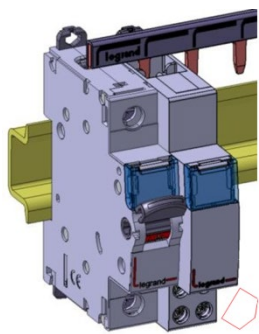

**2.** Pull the device forward in order to release it from the rail

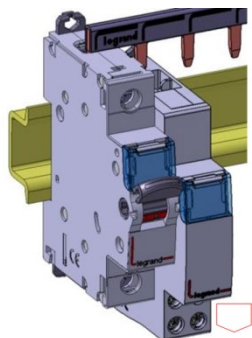

**3.** Pull the device downward in order to release it completely from the prongs of the busbar

# EMS CX<sup>3</sup> - Multifunction Measuring module with closed Rogowski coils

Cat. Nos: 4 149 15/16/18/19/20/21

## 5. GENERAL CHARACTERISTICS

### Front face marking:

. By permanent ink pad printing (red line) and laser marking



### Lateral side marking:

. By laser.

left side: Standard and programming information

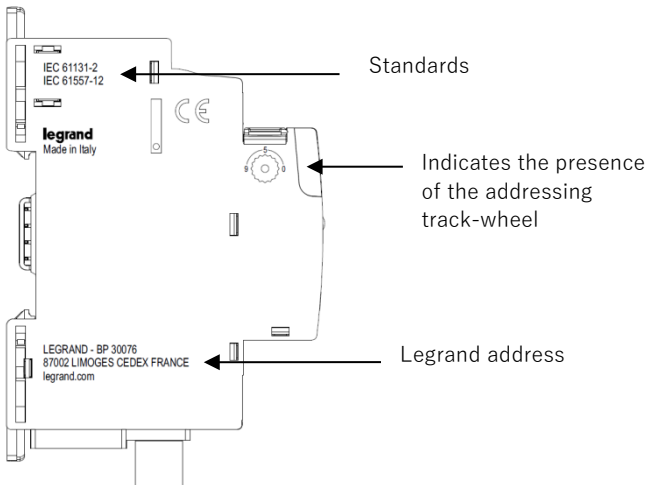

right side: cabling and traceability information

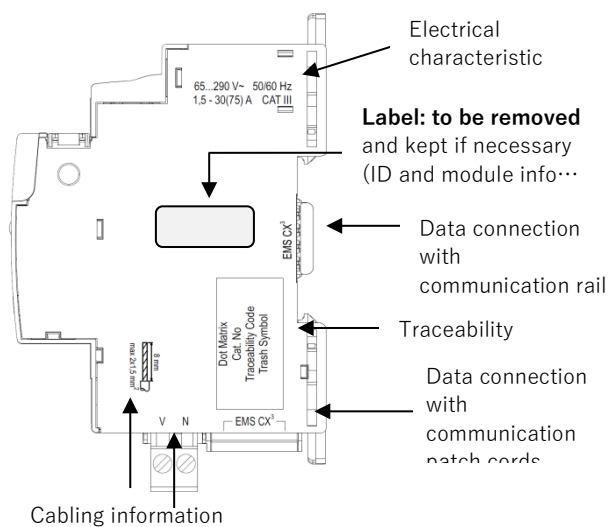

## 5. GENERAL CHARACTERISTICS (continued)

### Voltage measurement terminal block marking:

. By permanent ink pad printing.  
4 149 18/19      4 149 20/21

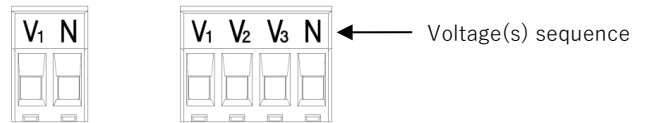

### Measuring LED:

. The device is equipped with a measuring LED; it gives information that the device is counting an energy consumption:  
- blinking red → 0,2 Wh per light pulse

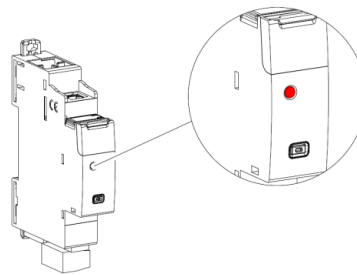

### Multi-Functions button:

. Front face button as several functions:

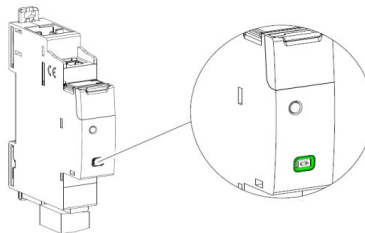

. Gives information about the operating state on the module  
Possible states:

Led colour	State	Meaning
red	Slow blinking	Error (e.g. addressing error)
	Fast blinking	No function
	Steady (pressing the multifunction button longer than 10 sec.)	Total reset [any firmware updates are preserved]
green	Slow blinking	System process is running. Wait until the Led turns steady
	Fast blinking (pressing the multifunction button for 5 sec.)	put in "Stand-by" the EMS CX <sup>3</sup> module (no remote action and communication available)
	Steady	System OK, connection is running
orange	Slow blinking	Creation of a link with "Link Functionality" procedure (see next §)
	Fast blinking	Device's firmware update in progress
	Steady	No function



## 5. GENERAL CHARACTERISTICS *(continued)*

### Link Functionality:

. This function allows you to link two EMS CX<sup>3</sup> modules to create automatic actions that, once programmed, can run independently without a connection to a manager is needed.

The basic rule is the link between an event (circuit breaker that trip, a threshold exceeded, etc.) and an action accordingly (signalling, opening of a circuit by motorized control or contactor, etc.).

Possible associations are:

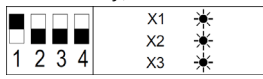
Event generator	Action module		
	Command: 4 149 32	State + Command: 4 149 31	State: 4 149 30
Measure: 4 149 18/19/20/21/ 22/23/24/25/27	✓	✓	✓ Only with the module configured (locally or remotely) as shown: 
State: 4 149 29/30	✓	✓	✗ Simply configure the module (locally or remotely) as "Slave"
State + Command: 4 149 31	✓	✓	✗ Simply configure the module (locally or remotely) as "Slave"

### Note:

- association can only be of type 1 to 1 (1 event and 1 action).
- modules already associated cannot be used for other associations.
- all the configuring procedure will be done with the Configuration Software (available online for free). *[For more details refer to the Installation Manual of EMS CX<sup>3</sup> Configuration software]*

## 5. GENERAL CHARACTERISTICS *(continued)*

### Link Functionality *(continued)*:

Modules compatible with "Link Functionality" feature: firmware versions and production date:

Cat n°	Firmware version	Production date indicated on the label stucked on the side of the module
4 149 18	all firmware versions	any production date
4 149 19	ver. ≥ 2.0.1	date ≥ 18W29
4 149 20	ver. ≥ 2.0.1	date ≥ 18W49
4 149 21	all firmware versions	any production date
4 149 22	all firmware versions	any production date
4 149 23	ver. ≥ 2.0.1	date ≥ 18W49
4 149 24	all firmware versions	any production date
4 149 25	all firmware versions	any production date
4 149 27	all firmware versions	any production date
4 149 29	ver. ≥ 2.0.1	date ≥ 18W49
4 149 30	ver. ≥ 2.0.2	date ≥ 18W32
4 149 31	ver. ≥ 2.0.6	date ≥ 18W45
4 149 32	ver. ≥ 3.0.2	date ≥ 18W39
4 149 36	ver. ≥ 2.0.4	date ≥ 18W38
4 149 37	ver. ≥ 2.0.4	date ≥ 18W43
4 149 40	ver. ≥ 3.0.8	date ≥ 18W34
4 238 90	all firmware versions	any production date
Circuit Breaker S10	all firmware versions	any production date

## 5. GENERAL CHARACTERISTICS *(continued)*

### Measured quantities and Accuracy class:

- . Current (accuracy 0,5):  
phase: I<sub>1</sub>, I<sub>2</sub>, I<sub>3</sub>;  
neutral: I<sub>N</sub>.
- . Voltage (accuracy 0,5):  
phase/phase: U<sub>12</sub>, U<sub>23</sub>, U<sub>31</sub>;  
phase/neutral: V<sub>1N</sub>, V<sub>2N</sub>, V<sub>3N</sub>.
- . Frequency (accuracy 0,1)
- . Power:  
instantaneous active total power, phase (accuracy 0,5);  
instantaneous reactive total power, phase (accuracy 1);  
instantaneous apparent total power, phase (accuracy 0,5);
- . Power factor a (accuracy 0,5).
- . Energy:  
total and partial active energy, positive and negative (accuracy 0,5);  
total and partial reactive energy, positive and negative (accuracy 2).
- . THD (accuracy 1):  
voltages THD: V<sub>1</sub>, V<sub>2</sub>, V<sub>3</sub> o U<sub>12</sub>, U<sub>23</sub>, U<sub>31</sub>;  
currents THD: I<sub>1</sub>, I<sub>2</sub>, I<sub>3</sub>, I<sub>N</sub>.
- . Harmonic analysis:  
Voltages: odd harmonics up to 15<sup>th</sup> (in display and via communication RS485);  
Currents: odd harmonics up to 15<sup>th</sup> (in display and via communication RS485);

**Note:** measurement accuracy is guaranteed only with the conductor correctly centred in each measuring sensor (see table of § "Connectable section" for proper use of the internal plastic support).

### Measuring sensors operating range:

- . Max Rogowski primary current:  
4 149 18/19/20 = 63 A  
4 149 21 = 125 A

### Insulation voltage (at voltages measurement terminals):

- . U<sub>i</sub> = 500 V (Ph-Ph)

### Impulse withstand voltage U<sub>imp</sub>:

- . EMS ports / Voltages input terminals:  
wave 1,2 / 50 μs: 6 kV  
alternate current 50 Hz / 1 min.: 3 kV
- . EMS ports / Current sensors input terminal:  
wave 1,2 / 50 μs: 6 kV  
alternate current 50 Hz / 1 min.: 3 kV

### Pollution degree:

- . 2 according to IEC/EN 60898-1.

### Overvoltage category:

- . III

### Dielectric strength:

- . 2500 V

## 5. GENERAL CHARACTERISTICS *(continued)*

### Plastic material:

- . Self-extinguishing polycarbonate.
- . Heat and fire resistant according to IEC/EN 60695-2-12, glow-wire test at 960° C.
- . Classification UL 94 / IECEN 60695-11-10: V1

### Ambient operating temperature:

- . Min. = -25° C. Max. = +70° C

### Ambient storage temperature:

- . Min. = -40° C. Max. = +70° C

### Protection Index:

- . Protection index of terminals against direct contacts: IP2X (IEC/EN 60529).
- . Protection index of terminals against solid and liquid bodies (wired device): IP 20 (IEC/EN 60529).
- . Protection index of the front face against solid and liquid bodies: IP 40 (IEC/EN 60529).
- . Class II, front panel with faceplate.

### Average weight per device:

- . Weight inclusive of measuring sensors

	kg
4 149 15	0,050
4 149 16	0,130
4 149 18	0,104
4 149 19	0,068
4 149 20	0,104
4 149 21	0,150

### Volume when packed:

	dm <sup>3</sup>
4 149 15 in bag of 1 piece (pack per 20 bags)	3,7
4 149 16 in bag of 1 piece (pack per 6 bags)	3,7
4 149 18/19/20/21	0,33

### Consumption:

- . Values at 12 VDC

	W	mA
4 149 18	0,419	34,8
4 149 19	0,410	34,1
4 149 20	0,419	34,8
4 149 21	0,419	34,8

## 5. GENERAL CHARACTERISTICS *(continued)*

### Load shedding Function:

- . Allows to automatically carry out load shedding in case of power demand when a circuit exceeds a threshold.
  - . Function is implementable using together following EMS CX<sup>3</sup> modules:
    - Universal Control module (cat. no 4 149 32) *(see § "Module configuration")*
    - Measurement modules (cat. nos 4 149 18/19/20/21/22/23/24/25/27)
- To set the different parameters it is necessary to use the EMS Configuration software (available online for free)

### . Procedure:

1. Assign the same address to the EMS CX<sup>3</sup> modules (Universal control and Measurement modules) which require to be linked
2. Connect a computer to the Modbus/EMS CX<sup>3</sup> interface or to the Mini configuration module (according to the system architecture type; see § "System architectures")
3. In the EMS Configuration software pages adjust the parameters:

### . In the dedicated page of the Measurement module:

- **Threshold:** value of Total active power (kW) above which procedure starts. *(default value 100 kW)*
- **Hysteresis:** value expressed in % of the threshold under which the alarm is over and the disconnected loads are restored. *(default value 5%, max value 100%)*
- **Alarm delay (s)** - *(default value 1 sec., max. value 30000 sec):*  
 during the activation of an alarm: is the waiting time between the threshold point and the alarm on the EMS bus  
 during the de-activation of an alarm: is the waiting time between the hysteresis point and the alarm is deactivation on the EMS bus

### . In the dedicated page of the Universal control module:

- **Relay normal state:** the rest position of the relay; normally open (NO) or normally closed (NC).
- **Relay activation:** impulsive or maintained
- **Relay activation time (s):** used for the impulsive work method only; represents the time in which the relay remains in the working position. *(default value 1 sec., max. value 6000 sec):*
- **Activation delay (s):** waiting time between the alarm on the EMS bus and the action done by the universal control module *(default value 0 sec, max. value 6000 sec):*

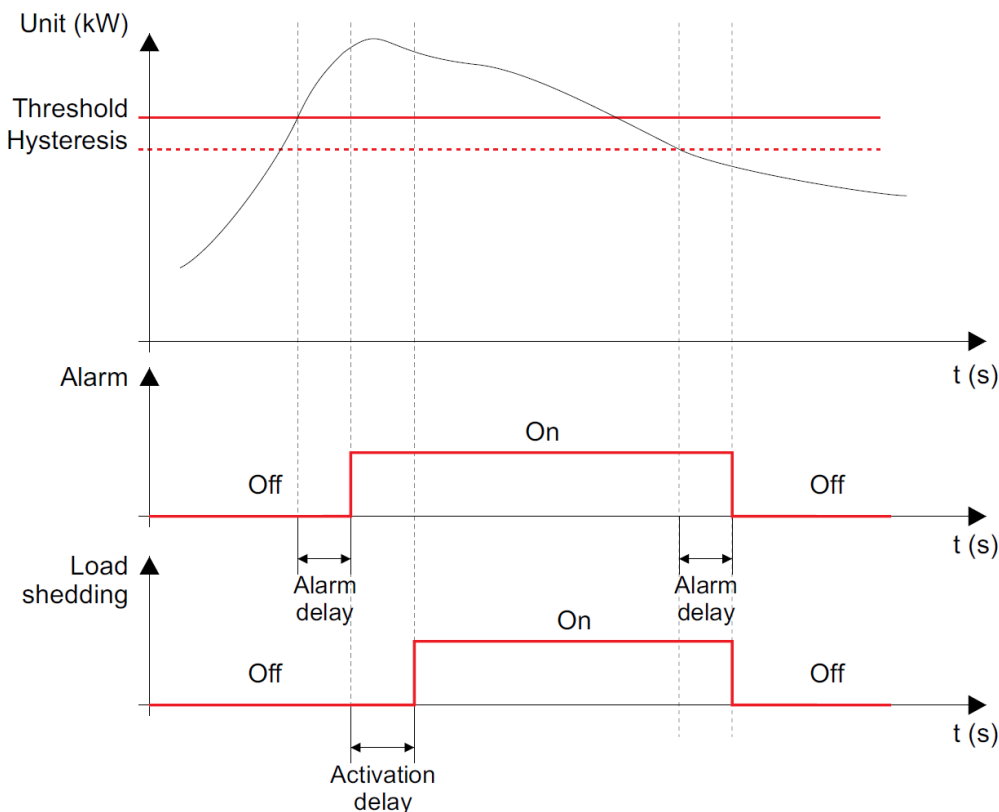

## 6. SYSTEM ARCHITECTURES

The EMS CX<sup>3</sup> is a polyvalent system and, according to the needs of the customer, can be set up and/or used as "Stand-alone" or "Supervised" system. Based on this choice the configuration and addressing methods are different.

Four possible architectures are provided:

### 6.1 Stand-alone system

6.1.1 with local addressing (through the track wheel)

6.1.2 with remote addressing (through a computer)

### 6.2 Supervised (Computer Supervisory System)

6.2.1 with local addressing

6.2.2 with remote addressing

### 6.1 Stand-alone system

. **Stand-alone** = autonomous system. To be used by the end-user if it is not necessary to have a computer for the supervision outside the envelope. Everything can be managed on site.

#### 6.1.1 Stand-alone system with local addressing (through the track wheel)

Local addressing advantages:

- No configuration software needed to set-up the installation
- **It is not necessary to use a computer to manage settings** (configurations, test, ...) and to use the system (visualize and be alerted, ...). Everything can be done through the Mini configuration module (local display, cat. no 4 149 36/37). [Refer to the technical sheet dedicated to this module for details].
- No communication Interfaces or gateways are required.
- Installation can be done without the intervention of a System Integrator

#### Programming procedure:

. For EMS CX<sup>3</sup> modules which need some: mandatory through the EMS CX<sup>3</sup> configurator (see § "Module configuration")

#### Addressing procedure:

. For all EMS CX<sup>3</sup> modules: mandatory through the track wheel located on the top upper face of each EMS CX<sup>3</sup> modules

. Marked from 0 to 9 in order to locally define the Modbus address of the EMS CX<sup>3</sup> modules

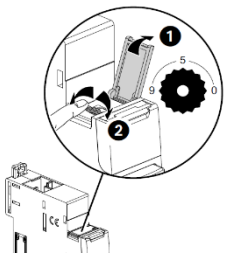

#### Note for Measure Module "3x single phase":

This module is to be consider as 3 modules with 3 different Modbus Address. The module takes automatically the two addresses immediately following to the programmed one (e.g. Programmed address = 2, Addresses of the module 2, 3, 4)

#### Consequences of the local addressing mode (through the track wheel):

- . Each device of the system must be addressed.
- . Addresses available: from 1 to 9
- . Address 0 not permitted
- . It is possible to assign to several devices the same address with the purpose of grouping different functions, **because they are related to the same electrical circuit**. For example, it is possible to assign the same address to a signalling auxiliary module (cat. no 4 149 29), a universal control module (cat. no 4 149 32), a measuring module, and so on. In this way on the EMS CX<sup>3</sup> mini configuration module (local display) the grouped function will be displayed as a unique "device" with all grouped functions. [Refer to the schemes hereunder]

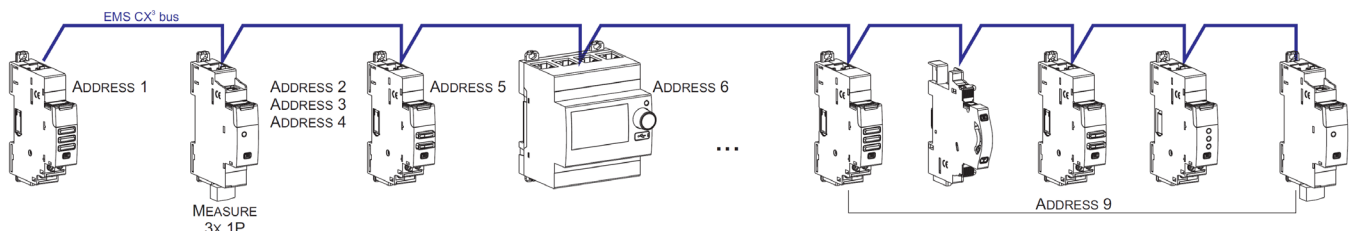

#### Note for the mini configuration module (local display)

It is necessary to assign the mini configurator a different address from all the other EMS CX<sup>3</sup> modules through the device programming menu.

. The mini configuration module can be placed everywhere in the EMS CX<sup>3</sup> bus

## 6. SYSTEM ARCHITECTURES

### 6.1 Stand-alone system *(continued)*

#### 6.1.2 Stand-alone system with remote addressing (through a computer)

Remote addressing advantages:

- Whole configuration (addresses and functions) can be set up through the EMS Configuration software
- Configuration software available for free
- **Automatic detection of the EMS CX<sup>3</sup> modules** installed in the system (characteristics, functions, configuration...)
- **Increased settings possibilities: load shedding function**
- Increased addressing: **up to 30 Modbus addresses in a system**

#### Programming procedure:

. For EMS CX<sup>3</sup> modules which need some: mandatory via the configuration software *(see § "Module configuration")*

#### Addressing procedure:

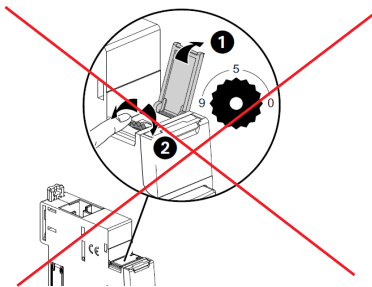

 The track wheel must be left in position "0".

. It is not necessary to assign an address via rotary, **the track wheel must be left in default position "0"**.

. All the addressing/configuring procedure will be done with the Configuration Software (available online for free)

. With remote addressing, the software does the automatic detection of modules installed in the system, but the supervision is not possible until the user assigns the remote address and all the characteristics to each module.

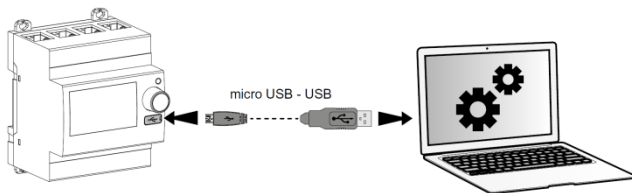

**Note: it is mandatory to connect the computer to the Mini configuration module with an USB-micro USB cable.** *[For more details, refer to the technical data sheet of the Mini configuration module EMS CX<sup>2</sup>]*



Read configuration from USB

Found:  
2 groups  
6 modules

Group modules in sets assigning the same address.  
Press "Continue" to save address in modules and import structure.

Found modules			
Module ID	Model	Address	Error
FFFF.FFFF.FFFF.FDE5	4 149 30/37 - EMS display	247	-
 FFFF.FFFF.FFFF.FD9B	4 149 30 - Generic input	1	-
 FFFF.FFFF.FFFF.FD89	4 149 32 - Generic command	2	-
 FFFF.FFFF.FFFF.FD88	4 149 26 - Pulse counter	3	-

 Click on this icon on the table to light the LED on the module

legrand

#### Note for Measure Module "3x single phase":

This module is to be consider as 3 modules with 3 different Modbus Address. The module takes automatically the two addresses immediately following to the programmed one (e.g. Programmed address = 2, Addresses of the module 2, 3, 4)

## 6. SYSTEM ARCHITECTURES

### 6.1 Stand-alone system *(continued)*

#### 6.1.2 Stand-alone system with remote addressing (through a computer) *(continued)*

#### Consequences for the system architecture:

- for 1 mini configuration module (cat. no 4 149 36/37)
  - o up to **30 EMS CX<sup>3</sup> modules** (e.g. 30 devices grouped per functions with addresses from 1 to 30)

It is possible to assign to several devices the same address with the purpose of grouping different functions, **because they are related to the same electrical circuit**. For example, it is possible to assign the same address to a signalling auxiliary module (cat. no 4 149 29), a universal control module (cat. no 4 149 32), a measuring module, and so on. In this way on the EMS CX<sup>3</sup> display or in a supervision system the grouped function will be displayed as a unique "device" with all grouped functions. *[Refer to the schemes here under]*

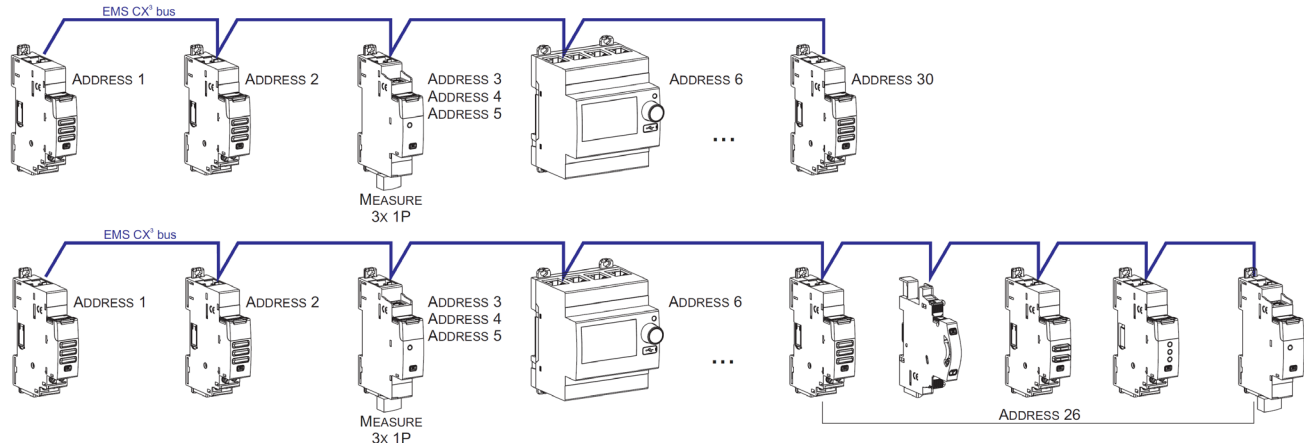

#### Note for the mini configuration module (local display)

- . It is necessary to assign the mini configurator a different address from all the other EMS CX<sup>3</sup> modules through the device programming menu.
- . The mini configuration module can be placed everywhere in the EMS CX<sup>3</sup> bus

### 6.2 Supervised system (Computer Supervisory System)

. **Supervised system** = System to be used through a Computer Supervisory System to remotely read data from the EMS CX<sup>3</sup> devices and/or do operations on these devices (e.g. commands of a motor driven or contactor ...).

#### 6.2.1 Supervised system-with local addressing (through the track wheel)

Local addressing advantages:

- No configuration software needed to set-up the installation
- Installation can be done without the intervention of a System Integrator

#### Programming procedure:

. For EMS CX<sup>3</sup> modules which need some: mandatory via the configuration software *(see § "Module configuration")*

#### Addressing procedure:

. For all EMS CX<sup>3</sup> modules: mandatory through the track wheel located on the top upper face of each EMS CX<sup>3</sup> modules

. Marked from 0 to 9 in order to locally define the Modbus address to EMS CX<sup>3</sup> modules

In this system the Modbus address of an EMS CX<sup>3</sup> module device or group of modules (several functions) is obtained considering the address of the interface Modbus/EMS CX<sup>3</sup> Interface as tenth and the address of a device or group of function as unit (e.g. Interface address 1 = 10 → address of module n° 5 = Modbus address 15)

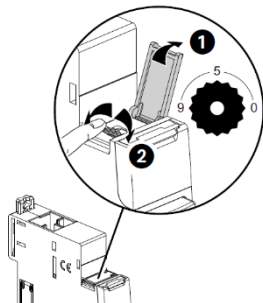

#### Note for Measure Module "3x single phase":

This module is to be consider as 3 modules with 3 different Modbus Address. The module takes automatically the two addresses immediately following to the programmed one (e.g. Programmed address = 12, Addresses of the module 12, 13, 14)

## 6. SYSTEM ARCHITECTURES *(continued)*

### 6.2 Supervised system (Computer Supervisory System) *(continued)*

#### 6.2.1 Supervised system with local addressing (through the track wheel) *(continued)*

#### Consequences of the local addressing mode (through the track wheel):

- . Each device of the system must be addressed.
- . Rotary position available: from 1 to 9
- . Rotary position in 0 not permitted

It is possible to assign to several devices the same address with the purpose of grouping different functions, **because they are related to the same electrical circuit**. For example, it is possible to assign the same address to a signalling auxiliary module (cat. no 4 149 29), a universal control module (cat. no 4 149 32), a measuring module, and so on. In this way on the EMS CX<sup>3</sup> display or in a supervision system the grouped function will be displayed as a unique “device” with all grouped functions. *[Refer to the scheme hereunder]*

**Note:** In this configuration the Modbus address of an EMS CX<sup>3</sup> module device or group of modules (several functions) is obtained considering the address of the interface Modbus/EMS CX<sup>3</sup> Interface as tenth and the address of a device or group of function as unit (e.g. Interface rotary 1 = 10 and device rotary = 5 → Modbus address = 15)

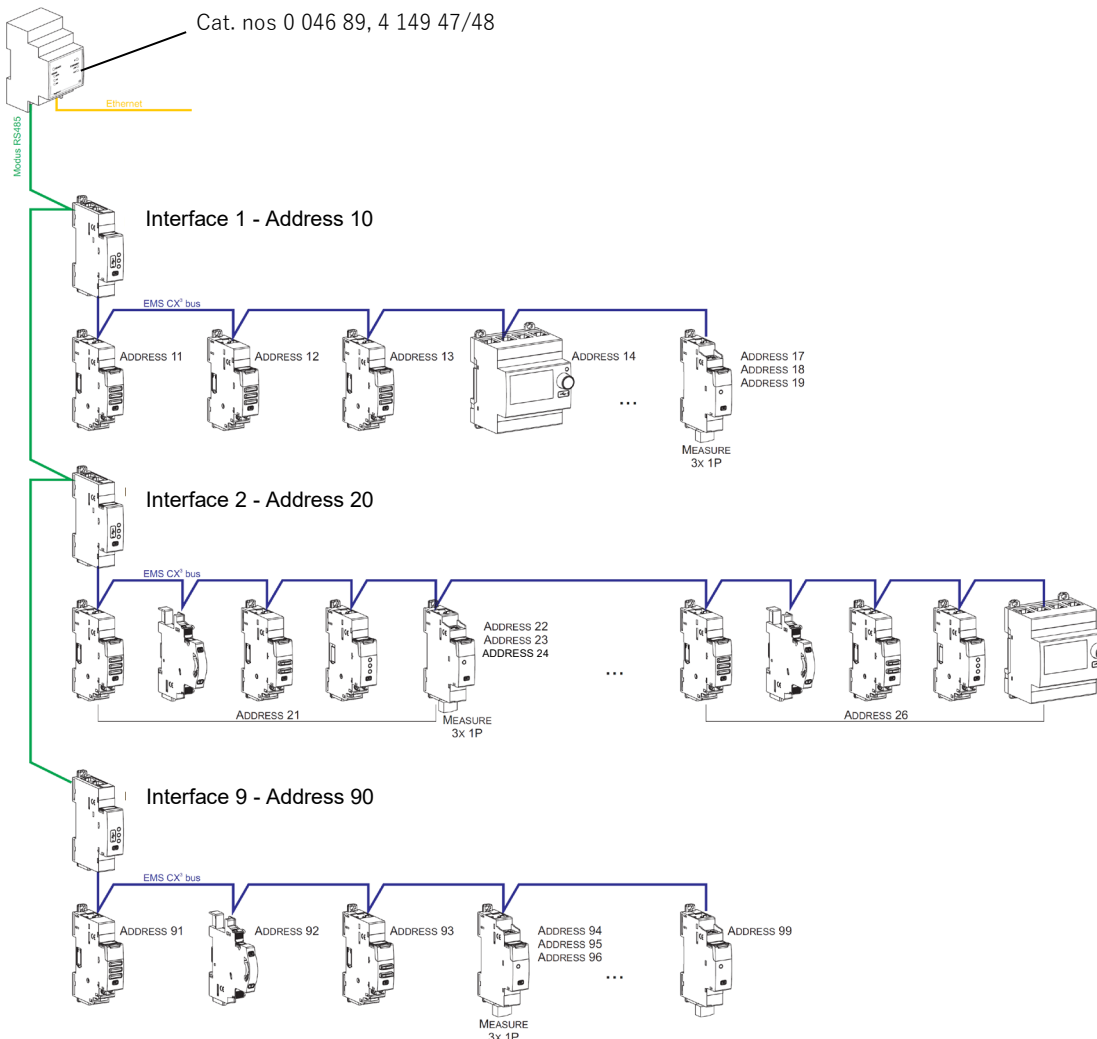

#### Consequences for the system architecture:

- for 1 IP/Modbus gateway (cat. no 0 046 89):
  - o up to **81 Modbus address**
  - o mandatory limit of max. **9 Modbus/EMS CX<sup>3</sup> interfaces** or max. **1000 m of Modbus cable** (cable Belden 9842, Belden 3106A or equivalent) or max. **50 m of Category 6 cable** (FTP or UTP).
- for 1 Modbus/EMS CX<sup>3</sup> Interface (cat. no 4 149 40):
  - o up to **30 EMS CX<sup>3</sup> modules** (ex. 30 devices grouped per functions with addresses from 1 to 9)

**Note:** with local addressing, the Modbus/EMS CX<sup>3</sup> interface, does the automatic detection of modules (characteristics, functions, configuration...)



## 6. SYSTEM ARCHITECTURES *(continued)*

### 6.2 Supervised system (Computer Supervisory System) *(continued)*

#### 6.2.2 Supervised system-with remote addressing (through a computer)

Remote addressing advantages:

- Whole of configuration (addresses and functions) can be done a remotely through the EMS Configuration software
- Configuration software available for free
- **Automatic detection of the EMS CX<sup>3</sup> modules** installed in the system (characteristics, functions, configuration...)
- **Increased settings possibilities: load shedding function**
- Increased addressing: **up to 32 Modbus/EMS CX<sup>3</sup> interfaces**
- Increased addressing: **up to 247 Modbus addresses in a system**

#### Programming procedure:

. For EMS CX<sup>3</sup> modules which need some: mandatory via the configuration software *(see § "Module configuration")*

#### Addressing procedure:

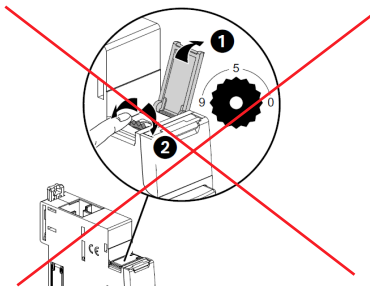

The track wheel must be left in position "0".

. It is not necessary to address the EMS CX<sup>3</sup> modules. **The track wheel must be left in default position "0".**

. all the addressing/configuring procedure will be done with the Configuration Software (available online for free)

. With remote addressing, the software does the automatic detection of modules installed in the system, but the supervision is not possible until the user assigns the remote address and all the characteristics to each module.

**Note: it is mandatory to connect the computer to the different Modbus/EMS CX<sup>3</sup> interface with an USB-micro USB cable (one interface at a time).** *[For more details, refer to the technical data sheet of the Modbus/EMS CX<sup>3</sup> interface]*

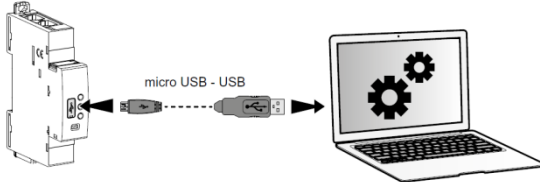

Read configuration from USB

Found:  
2 groups  
6 modules

Group modules in sets assigning the same address.  
Press "Continue" to save address in modules and import structure.

Found modules				
Module ID	Model	Address	Error	
FFFF.FFFF.FFFF.FCF1	4 149 40 - Modbus/EMS Interface	← 1 →	-	
FFFF.FFFF.FFFF.FDB9	4 149 32 - Generic command	← 2 →	-	
FFFF.FFFF.FFFF.FD9B	4 149 30 - Generic input	← 1 →	-	
FFFF.FFFF.FFFF.FDB8	4 149 26 - Pulse counter	← 3 →	-	

Click on this icon on the table to light the LED on the module

legrand

#### Note for Measure Module "3x single phase":

This module is to be consider as 3 modules with 3 different Modbus Address. The module takes automatically the two addresses immediately following to the programmed one (e.g. Programmed address = 2, Addresses of the module 2, 3, 4)

## 6. SYSTEM ARCHITECTURES *(continued)*

### 6.2 Supervised system (Computer Supervisory System) *(continued)*

#### 6.2.2 Supervised system-with remote addressing (through a computer) *(continued)*

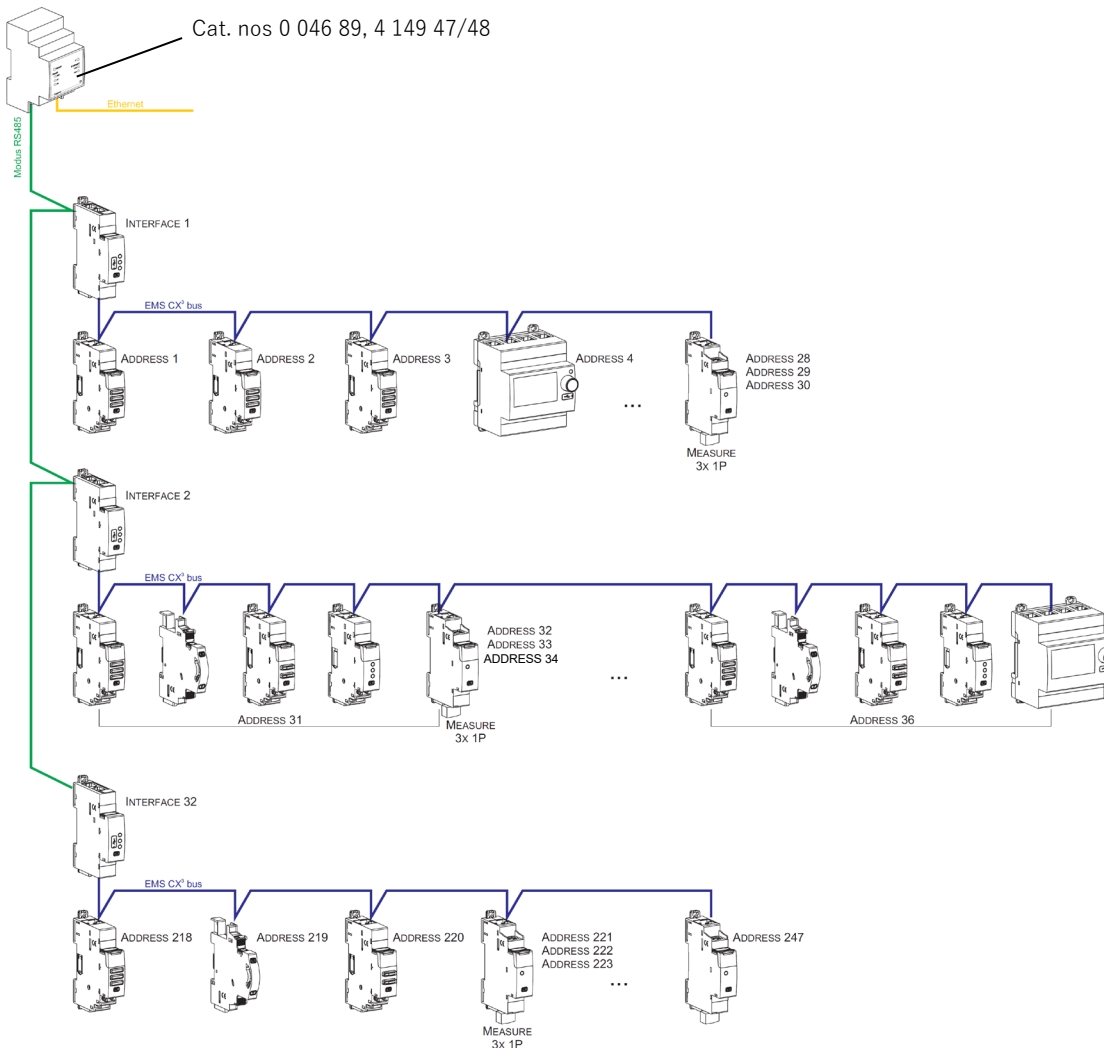

#### Consequences for the system architecture:

- for 1 IP/Modbus gateway (cat. no 0 046 89):
  - o up to **247 Modbus address**
  - o Because of Modbus: mandatory limit of max. **32 Modbus/EMS CX<sup>3</sup> interfaces** or max. **1000 m of Modbus cable** (cable Belden 9842, Belden 3106A or equivalent) or max. **50 m of Category 6 cable** (FTP or UTP).
- for 1 Modbus/EMS CX<sup>3</sup> Interface (cat. no 4 149 40):
  - o up to **30 EMS CX<sup>3</sup> modules or grouped modules** (e.g. 30 devices grouped per functions with rotary from 1 to 30)

It is possible to assign to several devices the same address with the purpose of grouping different functions, **because they are related to the same electrical circuit**. For example, it is possible to assign the same address to a signalling auxiliary module (cat. no 4 149 29), a universal control module (cat. no 4 149 32), a measuring module, and so on. In this way on the EMS CX<sup>3</sup> display or in a supervision system the grouped function will be displayed as a unique "device" with all grouped functions. *[Refer to the scheme up here]*

## 7. COMPLIANCE AND APPROVALS

### Compliance to standards:

- . Compliance with Directive on electromagnetic compatibility (EMC) n° 2014/30/EU
- . Compliance with low voltage directive n° 2014/35/EU.
- . Electromagnetic Compatibility:
  - emission according IEC/EN 61326-1, class B
  - immunity according IEC/EN 61326-1.

### Conformity table to IEC 61557-12 Edition 2 (2018/10/22)

Performance measuring and monitoring devices (PMD) characteristics		
Type of characteristic	Specification values	Other complementary characteristics
Classification of PMD according 4.3	PMD-x (*)	-
Classification of PMD according 4.4	DD	-
Temperature	K55	-
Humidity + Altitude	Standard conditions	-
Active power and Active energy function performance class	0,5	-

(\*) PMD-III without Eap

# EMS CX<sup>3</sup> - Multifunction Measuring module with closed Rogowski coils

Cat. Nos: 4 149 15/16/18/19/20/21

## 7. COMPLIANCE AND APPROVALS *(continued)*

Conformity table to IEC 61557-12 Edition 2 (2018/10/22) *(continued)*

Function symbols	Function performance class according to IEC 61557-12	Measuring range	Other complementary characteristics
P	0,5	1,0 ÷ 75 A (4 149 18/19/20) 2,0 ÷ 150 A (4 149 21)	-
Q <sub>V</sub>	1	2,0 ÷ 75 A (4 149 18/19/20) 4,0 ÷ 150 A (4 149 21)	-
S <sub>A</sub>	0,5	1,0 ÷ 75 A (4 149 18/19/20) 2,0 ÷ 150 A (4 149 21)	-
E <sub>a</sub>	0,5	1,0 ÷ 75 A (4 149 18/19/20) 2,0 ÷ 150 A (4 149 21)	-
E <sub>rV</sub>	2	2,0 ÷ 75 A (4 149 18/19/20) 4,0 ÷ 150 A (4 149 21)	-
E <sub>apA</sub> , E <sub>apV</sub>	-	-	-
f	0,1	45 ÷ 65 Hz (4 149 18/19/20/21)	-
I	0,5	2,0 ÷ 75 A (4 149 18/19/20) 4,0 ÷ 150 A (4 149 21)	-
I <sub>Nc</sub>	0,5	2,0 ÷ 75 A (4 149 18/19/20) 4,0 ÷ 150 A (4 149 21)	-
U, V	0,5	65 ÷ 290 V (Ph-N) 110 ÷ 500 V (Ph-Ph)	-
P <sub>FA</sub>	0,5	Over 360 degrees	-
U <sub>dip</sub>	-	-	-
U <sub>swl</sub>	-	-	-
U <sub>tr</sub>	-	-	-
U <sub>int</sub>	-	-	-
U <sub>nba</sub>	-	-	-
U <sub>nb</sub>	-	-	-
V <sub>h</sub>	2	65 ÷ 290 V (Ph-N) 110 ÷ 500 V (Ph-Ph)	-
THD <sub>u</sub> , THD <sub>v</sub>	1	65 ÷ 290 V (Ph-N) 110 ÷ 500 V (Ph-Ph)	-
THD-R <sub>u</sub>	-	-	-
I <sub>h</sub>	5	6,3 ÷ 75 A (4 149 18/19/20) 15,5 ÷ 150 A (4 149 21)	-
THD <sub>i</sub>	1	6,3 ÷ 75 A (4 149 18/19/20) 15,5 ÷ 150 A (4 149 21)	-
THD-R <sub>i</sub>	-	-	-
P <sub>st</sub>	-	-	-
P <sub>lt</sub>	-	-	-

## 7. COMPLIANCE AND APPROVALS *(continued)*

### Environment respect - Compliance with EU directives:

- . Compliance with Directive 2011/65/EU as amended by Directive 2015/863 (RoHS 2) on the restriction of the use of certain hazardous substances in electrical and electronic equipment.
- . Compliance with REACH regulation (1907/2006): at the date of the publication of this document no element of the SVHC substance list (updated on 27/06/2018) is present in these products.
- . WEEE directive (2012/19/EU): the sale of this product is subject to a contribution to eco-organisations in each country responsible for managing end-of-life products in the field of application of the European Waste Electronic and Electrical Equipment Directive.

### Plastic materials:

- . Halogens-free plastic materials.
- . Marking of parts according to ISO 11469 and ISO 1043.

### Packaging:

- . Design and manufacture of packaging compliant to decree 98-638 of the 20/07/98 and also to directive 94/62/CE.

### Environmental profile:

- . PEP document available

### Installation software:

- . XL PRO<sup>3</sup>.