

DX³ 4-pole RCBO 6000 A

Cat. N°(s) : 4 111 85, 86, 87, 88, 89 / 4 112 04, 05, 06, 07, 4 112 08, 23, 24, 25, 26, 27, 28, 29, 30, 31, 32, 33, 34, 35, 4 112 36, 37, 38, 39, 40, 41, 42, 44, 45, 46, 47, 4 113 50, 56, 57, 59, 60, 61, 62, 80, 81



CONTENTS	PAGE
1. Description, use	1
2. Range	1
3. Overall dimensions	1
4. Preparation - Connection	1
5. General characteristics	3
6. Compliance and approvals	6
7. Curves	7
8. Auxiliaries and accessories	16
9. Safety	16

1. DESCRIPTION - USE

Residual Current Operated Circuit Breaker (RCBO) with positive contact indication for control, protection against short circuits and overload and isolation of electrical circuits, protecting people from direct and indirect contact and protecting installations from insulation faults.

Symbol:

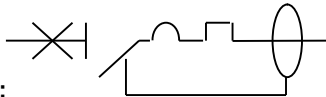

Technology:

- . Limiting device
- . Simultaneous control of all poles for closing and opening (trip-free mechanism)

2. RANGE

Polarity:

- 4 protected poles

Width:

- . 4 modules (4 x 17.8 mm = 71,2 mm)

Rated currents In:

- 10 / 13 / 16 / 20 / 25 / 32 A

Magnetic tripping curve:

- . C (between 5 and 10 In)
- . B (between 3 and 5 In)

Type:

- . AC (sinusoidal differential alternating current)
- . A (residual current with a DC component)
- . F (immunised against false tripping). F products are also A type.

Sensitivity – Operating time:

- . 30 mA - instantaneous
- . 300 mA - instantaneous
- . 1 000 mA - instantaneous

2. RANGE (continued)

Rated voltage and frequency:

- . 230/400 V~, 50 Hz with standard tolerances
- . 240/415 V~, 50 Hz with standard tolerances

Maximum operating voltage:

- . 440 V~, 50 Hz with standard tolerances

Breaking capacity:

- . Icn = 6000 A certified according to the standard EN/IEC 61009-1
- . Icu = 6 kA tested according to the standard EN/IEC 60947-2

3. OVERALL DIMENSIONS:

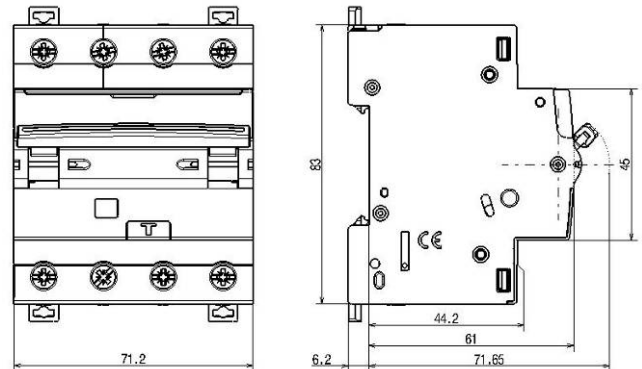

4. PREPARATION - CONNECTION

Mounting:

- . On symmetrical EN 60.715 rail or DIN 35 rail

Operating positions:

- . Vertical horizontal upside down On the side

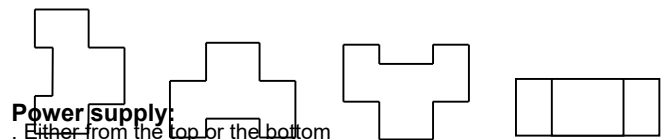

DX³ 4-pole RCBO 6000 A

Cat. N°(s) : 4 111 85, 86, 87, 88, 89 / 4 112 04, 05, 06, 07,
4 112 08, 23, 24, 25, 26, 27, 28, 29, 30, 31, 32, 33, 34, 35,
4 112 36, 37, 38, 39, 40, 41, 42, 44, 45, 46, 47,
4 113 50, 56, 57, 59, 60, 61, 62, 80, 81

4. PREPARATION - CONNECTION (continued)

400V three-phase network wiring without neutral:
connect the 3 phases as indicated by the arrows in below diagram

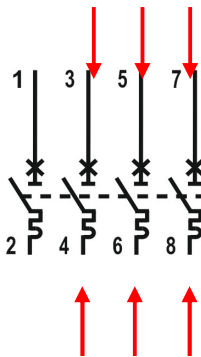
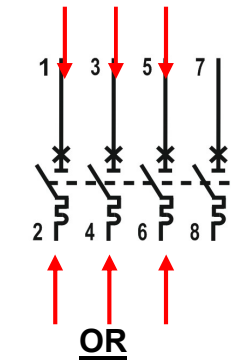

Module maintenance :

. A RCBO may be replaced in the middle of a row supplied with busbars without disconnecting the other products

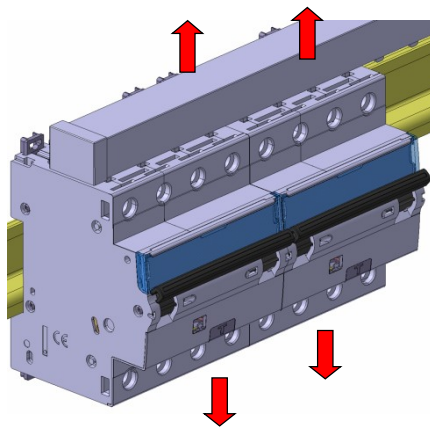

Put the clamp in the unlocking position

Unscrew the four upper terminals completely

Pull the device forward in order to release it from the rail

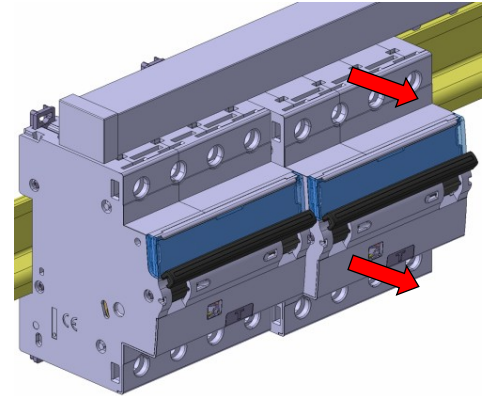

Pull the device downward in order to release it completely from the prongs of the busbar

Connection:

- . Terminals protected wired
- . Cage terminals, with r
- . Terminals fitted with
- . Alignment and spac
- . busbars
- . Terminal depth: 13 m
- . Screw head: mixed, s
- . Tightening torque:
 - Recommended: 2.5 Nm
 - Min.: 1.2 Nm
 - Max.: 3.5 Nm

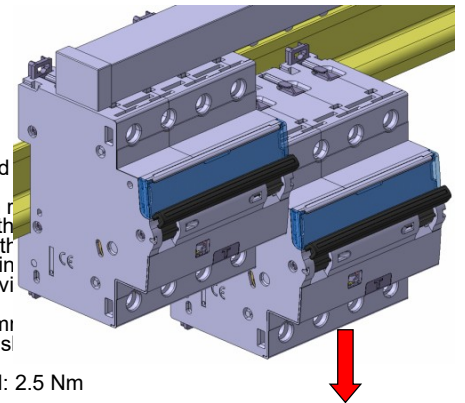

DX³ 4-pole RCBO 6000 A

Cat. N°(s) : 4 111 85, 86, 87, 88, 89 / 4 112 04, 05, 06, 07,
4 112 08, 23, 24, 25, 26, 27, 28, 29, 30, 31, 32, 33, 34, 35,
4 112 36, 37, 38, 39, 40, 41, 42, 44, 45, 46, 47,
4 113 50, 56, 57, 59, 60, 61, 62, 80, 81

4. PREPARATION - CONNECTION (continued)

Conductor type:

- Copper cable
- Cable cross-section:

	Without ferrule	With ferrule
Rigid cable	1 x 0.75 mm ² to 35 mm ² 2 x 0.75 mm ² to 16 mm ²	-
Flexible cable	1 x 0.75 mm ² to 25 mm ² 2 x 0.75 mm ² to 16 mm ²	1 x 0.75 mm ² to 25 mm ²

- Prong supply busbar at the top or the bottom of the product, alone or with a 16 mm² flexible wire (without ferrule) or a connection terminal in the same terminal.
- Fork supply busbar at the bottom of the product

Recommended tools:

- For the screw terminals, screwdriver with 5.5 mm to 6.5 mm blade or Pozidriv no. 2 screwdriver
- For attaching or removing the DIN rail, screwdriver with 5.5 mm to 6.5 mm blade or Pozidriv no. 2 screwdriver

Manual actuation of the RCBO

- Ergonomic 2-position handle:
- "O-OFF": Device open
- "I-ON": Device closed

Contact status display:

- By marking of the handle:
- "O-OFF" in white on a green background = contacts open
- "I-ON" in white on a red background = contacts closed

Trip indication on residual current fault:

- Yellow indicator on the front

Locking:

- Padlocks possible in the open or closed positions with padlock support (Cat. No. 4 063 03) and Ø 5 mm padlock (Cat. No. 4 063 13) or Ø6 mm padlock (Cat. No. 227 97)

Sealing:

- Possible in the open or closed positions

Labelling:

- Circuit identification by way of a label inserted in the label holder situated on the front of the product

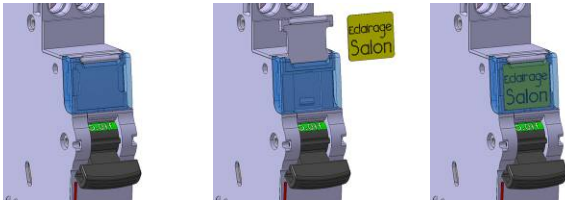

5. GENERAL CHARACTERISTICS

Neutral earthing system:

- IT, TT, TN

Marking on the front side:

- By permanent ink pad printing



Marking on the upper panel:

- By permanent ink pad printing

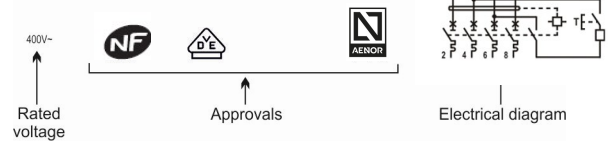

5. GENERAL CHARACTERISTICS (continued)

Test operating voltages:

I Δ n	30 mA	300 mA	1000 mA
min. U	320 V~	220 V~	230 V~
max. U	440 V~	440 V~	440 V~

Breaking capacity:

. With a three-phase network + neutral (with alternating current 50 Hz)

Standard	Voltage between poles	Breaking capacity	
Certified according to the standard EN/IEC 61009-1	230 V	I _{cn}	6 kA
	400 V		6 kA
Tested according to the standard EN/IEC 60947-2	230 V	I _{cu}	6 kA
	400 V		6 kA

Residual breaking capacity (beaking capacity on TN system):

. I Δ m = 4.5 kA in accordance with EN 61009-1 section 9.12.11.4d (I Δ m: short-circuit to earth)

Breaking capacity on one single pole (phase pole):

. In accordance with I_{IT} EN60947-2 – Appendix H (double fault in IT system): 3 kA at 400 V ~ and 6 kA at 230 V~

Isolation distance:

. The distance between the contacts is greater than 5.5 mm with the handle in the open position. The RCBO is suitable for isolation in accordance with standard EN/IEC 61009-1

Insulation voltage:

. U_i = 500 V in accordance with standard EN/IEC 61009-1

Dielectric strength:

. 3,500 V

Rated impulse withstand voltage:

. U_{imp} = 4 kV (wave 1.2/50 μ s)

Protection from false tripping:

. 8/20 μ s wave resistance: 250 A
. 0.5 μ s/100 kHz damped recurring wave resistance: 200 A

Degree or class of protection:

. Terminals protected against direct contact, Class of protection against solid objects and liquids (wired device): IP20 in accordance with standards IEC 529 – EN 60529 and NF 20-010
. Front panel protected against direct contact: IP 40
. Class II in relation to metallic conductive parts
. Class of protection against mechanical impacts IK 02 in accordance with standard EN 62262.

5. GENERAL CHARACTERISTICS (continued)

Degree of pollution:

. 2 in accordance with standard EN/IEC 61009-1

Plastic materials:

. Polyamide and P.B.T.

Enclosure heat and fire resistance:

. Resistance to glow wire tests at 960°C, in accordance with standard IEC/EN 61009-1
. Classification V0, in accordance with standard UL94

Higher heating potential:

. The heat potential of a 30 mA AC type C16 device is estimated at: 4.73 MJ

Closing and opening force via the handle:

. 6 N on opening
. 20 N on closing

Mechanical endurance:

Compliant with standard EN/IEC 61009-1
. Tested with 20,000 operations with no load

Electrical endurance:

Compliant with standard EN/IEC 61009-1

. Tested with 10,000 operations with load (at I_n x Cos ϕ 0.9)
. Tested with 2,000 residual current trip operations using the Test button or the fault current

Sinusoidal vibration resistance (in accordance with IEC 60068.2.6):

. Axes: x - y - z
. Frequency: 10 to 55 Hz
. Acceleration: 3g (1g = 9.81 m.s⁻²)

Resistance to tremors:

. In accordance with standard EN/IEC 61009-1

Ambient temperatures:

. Operation: from – 25°C to + 60°C
. Storage: from – 40°C to + 70°C

DC operation:

. Cannot be used with DC

Frequency:

. Operation at 400 Hz: No
. Operation at 60 Hz: Yes., except sensitivities 30mA, A and AC types, which can be replaced, only for ratings 16A,20A,25A,32A, by F types of equivalent ratings and sensitivity.

Packaged volume:

	Volume (dm ³)	Packaging
For all ratings	0.7	Per 1

Average weight per device:

. 30mA RCBOs= 0,48 kg
. 300mA RCBOs= 0,45 kg
. 1 A RCBOs= 0,45 kg

5. GENERAL CHARACTERISTICS *(continued)*

Derating of RCBOs function of the number of devices placed side by side:

When several RCBOs are installed side by side and operate simultaneously, the heat dissipation of one pole is limited. This results in an increased operating temperature for the RCBOs causing false tripping. Applying the following additional coefficients to the operating currents is recommended.

Number of RCBOs side by side	Coefficient
2 - 3	0.9
4 - 5	0.8
6 - 9	0.7
≥ 10	0.6

These values are provided by recommendation IEC 60439-1 and the standards NF C 63421 and EN 60439-1. In order to avoid having to use these coefficients there must be good ventilation and the devices must be kept apart using the spacing elements Cat. No. 4 063 07 (0.5 module).

Derating of RCBOs in the event of use with fluorescent tubes:

Electronic or ferromagnetic ballasts provide a high inrush current for a very short time. These currents are liable to cause tripping of the RCBOs.

The maximum number of ballasts per RCBOs stated by the lamp and ballast manufacturers in their catalogues should be taken into account during installation.

Impact of height:

	≤2,000 m	3,000 m	4,000 m	5,000 m
Dielectric strength	3,500 V	2,500 V	2,000 V	1,500 V
Maximum operating voltage	400 V	400 V	400 V	400 V
Derating at 30°C	none	none	none	none

Dissipated power (per device):

. B and C curve RCBOs, all types and all sensitivities

Rated current	10 A	13 A	16 A	20 A	25 A	32 A
Power (W)	4.7	5.7	8.9	9.3	10.4	12.3

Derating of RCBOs depending on the ambient temperature:

. The nominal characteristics of a RCBO are modified depending on the ambient temperature which prevails in the cabinet or enclosure where the RCBO is located.

. Reference temperature: 30°C in accordance with standard IEC/EN 60947-2.

In (A)	Ambient Temperature/In								
	- 25°C	- 10°C	0°C	10°C	20°C	30°C	40°C	50°C	60°C
10	13	12	12	11	11	10	9.5	9	8.5
13	17	16	15	14	14	13	12.35	11.7	11.05
16	20	19	18	18	18	16	15.2	14.4	13.6
20	26	24	23	22	21	20	19	18	17
25	32	30	29	28	26	25	23.75	22.5	21.25
32	41	38	37	35	34	32	30.4	28.8	27.2

Specific use:

. Appropriate to operate in humid atmosphere and polluted by a chlorinated environment (pool-type)

6. COMPLIANCE AND APPROVALS

In accordance with standards:

- . EN/IEC 61009-1 (NF C 61440)
- . EN/IEC 62423 (F type)

Usage in special conditions:

- . Category C compliant (testing temperature range range from -25°C to +70°C, resistant to salt spray) in accordance with the classification defined in Appendix Q of standard IEC/EN 60947-1

Respect for the environment – Compliance with European Union Directives:

- . Compliance with Directive 2002/95/EC of 27/01/03 known as "RoHS" which provides for a restriction on the use of dangerous substances such as lead, mercury, cadmium, hexavalent chromium and polybrominated biphenyl (PBB) and polybrominated diphenyl ether (PBDE) brominated flame retardants from 1st July 2006
- . Compliance with the Directive 91/338/EEC of 18/06/91 and decree 94-647 of 27/07/04

Plastic materials:

- . Halogen free plastic materials
- . Labelling of parts compliant with ISO 11469 and ISO 1043.

Packaging:

- . Design and manufacture of packaging compliant with decree 98-638 of 20/07/98 and Directive 94/62/EC

Approvals obtained:

- . France: NF

7. CURVES

Thermal-magnetic tripping curve range typical of B and C curve RCBOs:

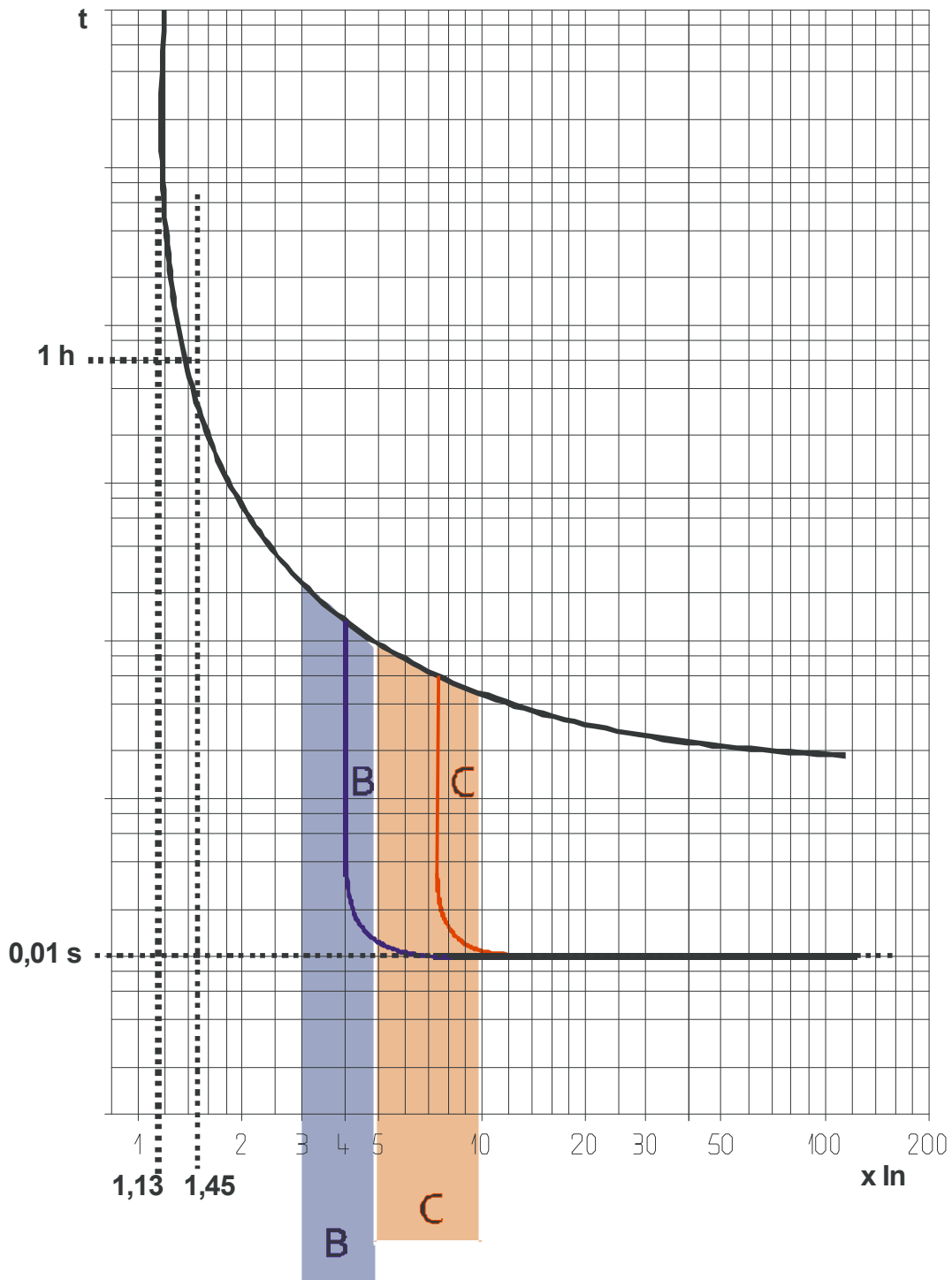

Thermal tripping at ambient temperature = 30°C
 I_n = RCBO rated current

DX³ 4-pole RCBO 6000 A

Cat. N°(s) : 4 111 85, 86, 87, 88, 89 / 4 112 04, 05, 06, 07,
 4 112 08, 23, 24, 25, 26, 27, 28, 29, 30, 31, 32, 33, 34, 35,
 4 112 36, 37, 38, 39, 40, 41, 42, 44, 45, 46, 47,
 4 113 50, 56, 57, 59, 60, 61, 62, 80, 81

7. CURVES (continued)

Average thermal-magnetic tripping curves range typical of B curve RCBOs:

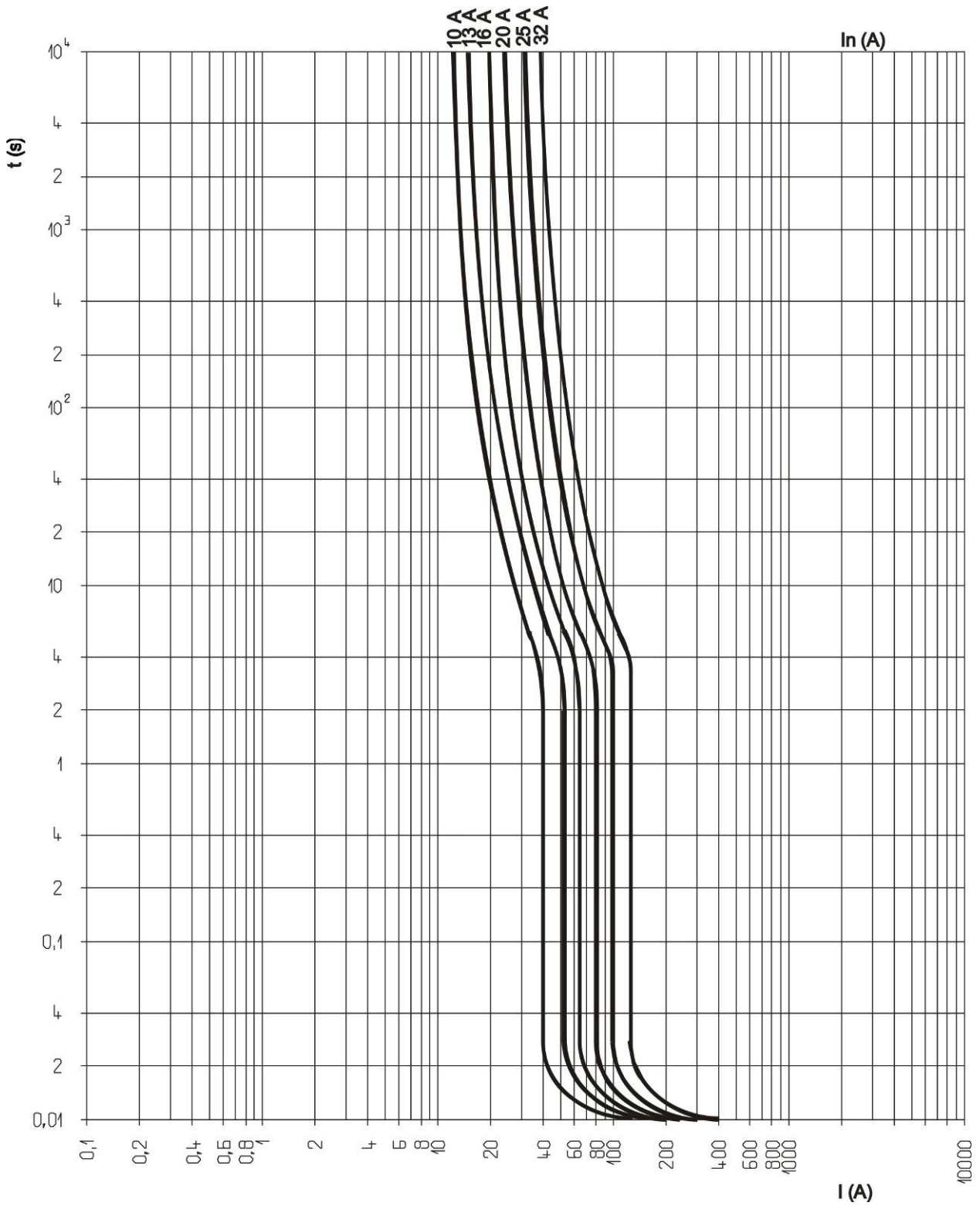

DX³ 4-pole RCBO 6000 A

Cat. N°(s) : 4 111 85, 86, 87, 88, 89 / 4 112 04, 05, 06, 07,
4 112 08, 23, 24, 25, 26, 27, 28, 29, 30, 31, 32, 33, 34, 35,
4 112 36, 37, 38, 39, 40, 41, 42, 44, 45, 46, 47,
4 113 50, 56, 57, 59, 60, 61, 62, 80, 81

7. CURVES (continued)

Average thermal-magnetic tripping curves range typical of C curve circuit RCBOs:

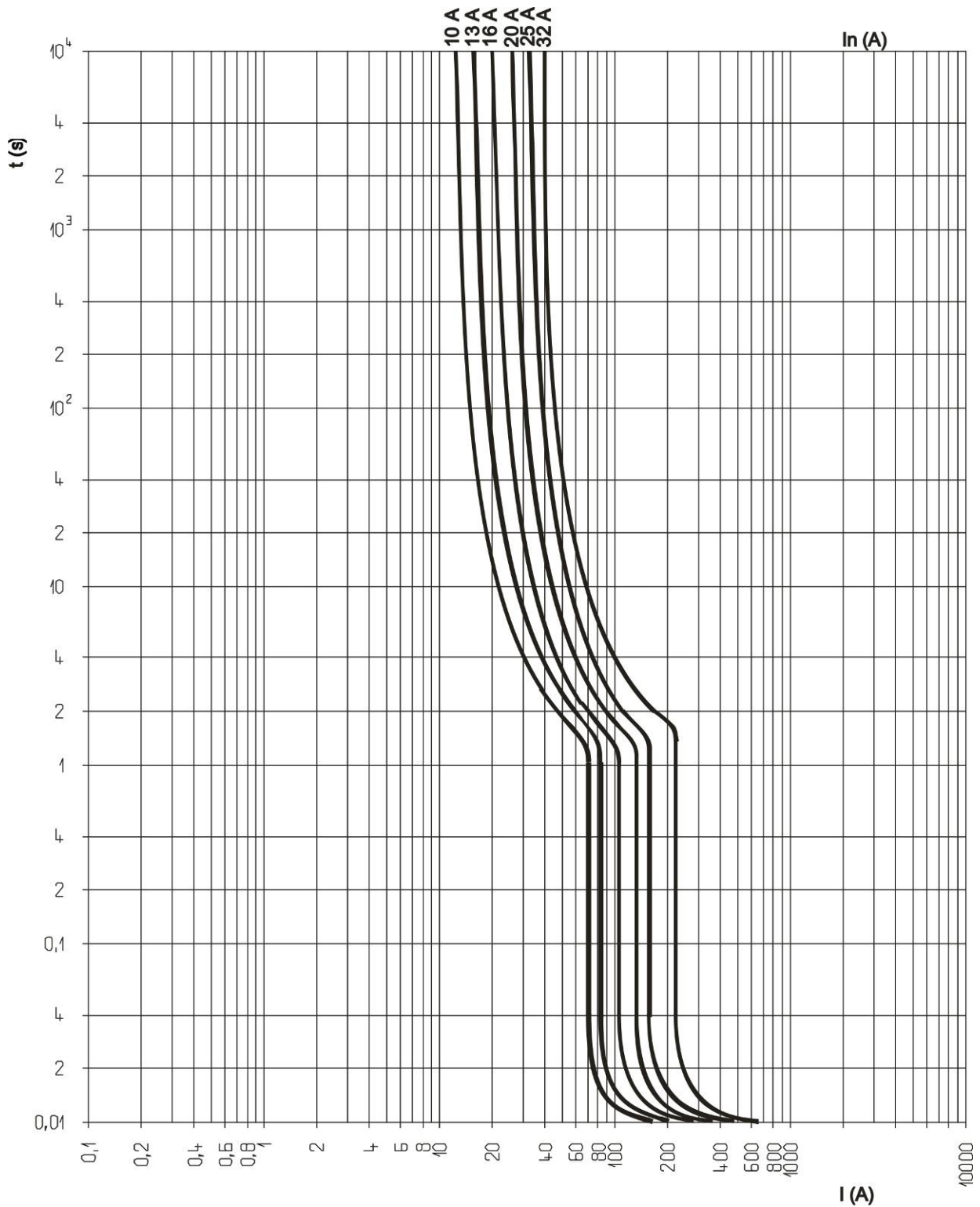

7. CURVES (continued)

Current limiting curves:

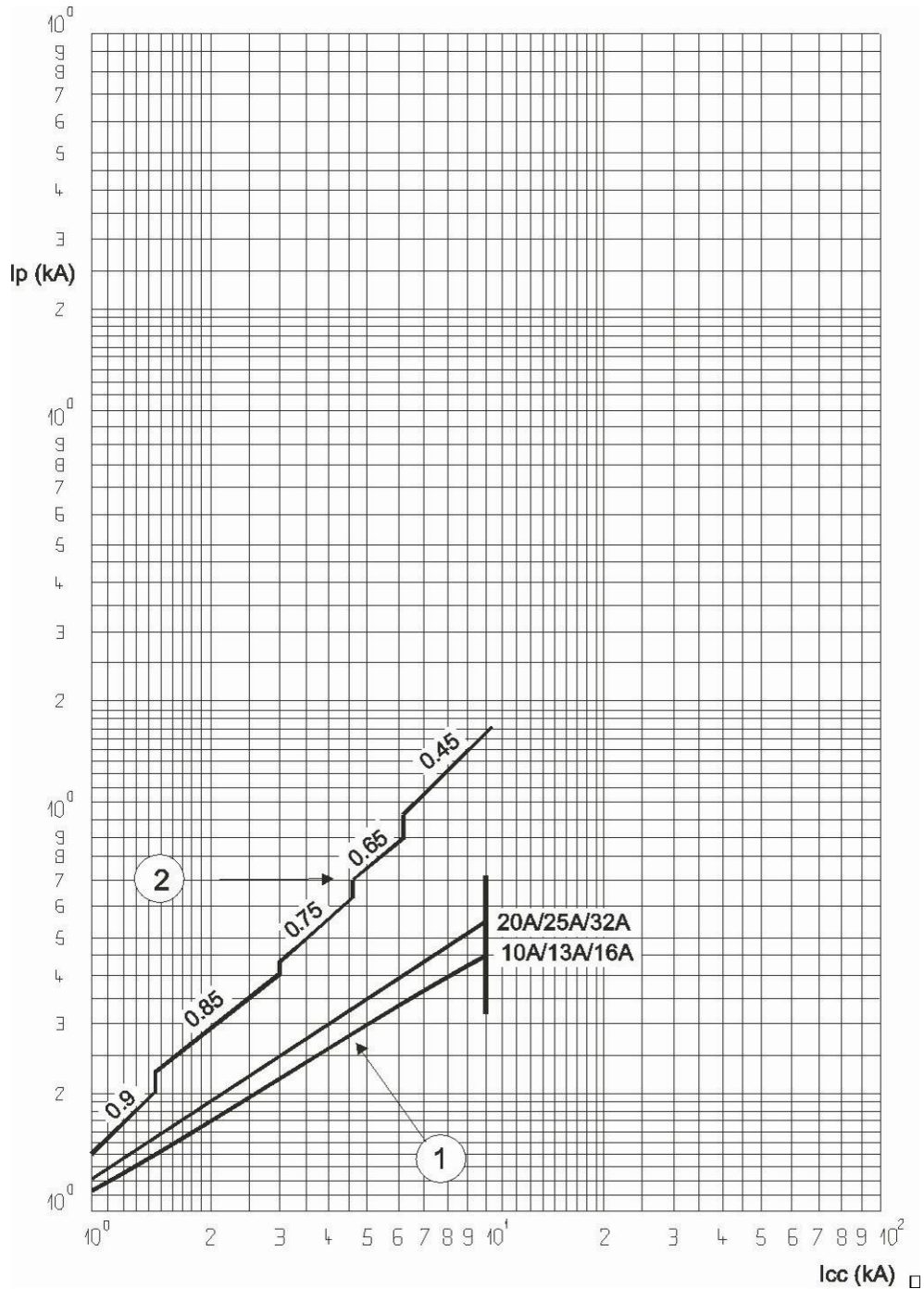

I_{cc} = Prospective short-circuit symmetrical current (rms value in kA)

I_p = Maximum peak value (kA)

① = Short-circuit rms currents (max. peak)

② = Unlimited peak currents (max), corresponding to power factors shown above (0.15 to 0.9)

7. CURVES (continued)

Thermal stress limiting curves:

. B curve 4-pole RCBO

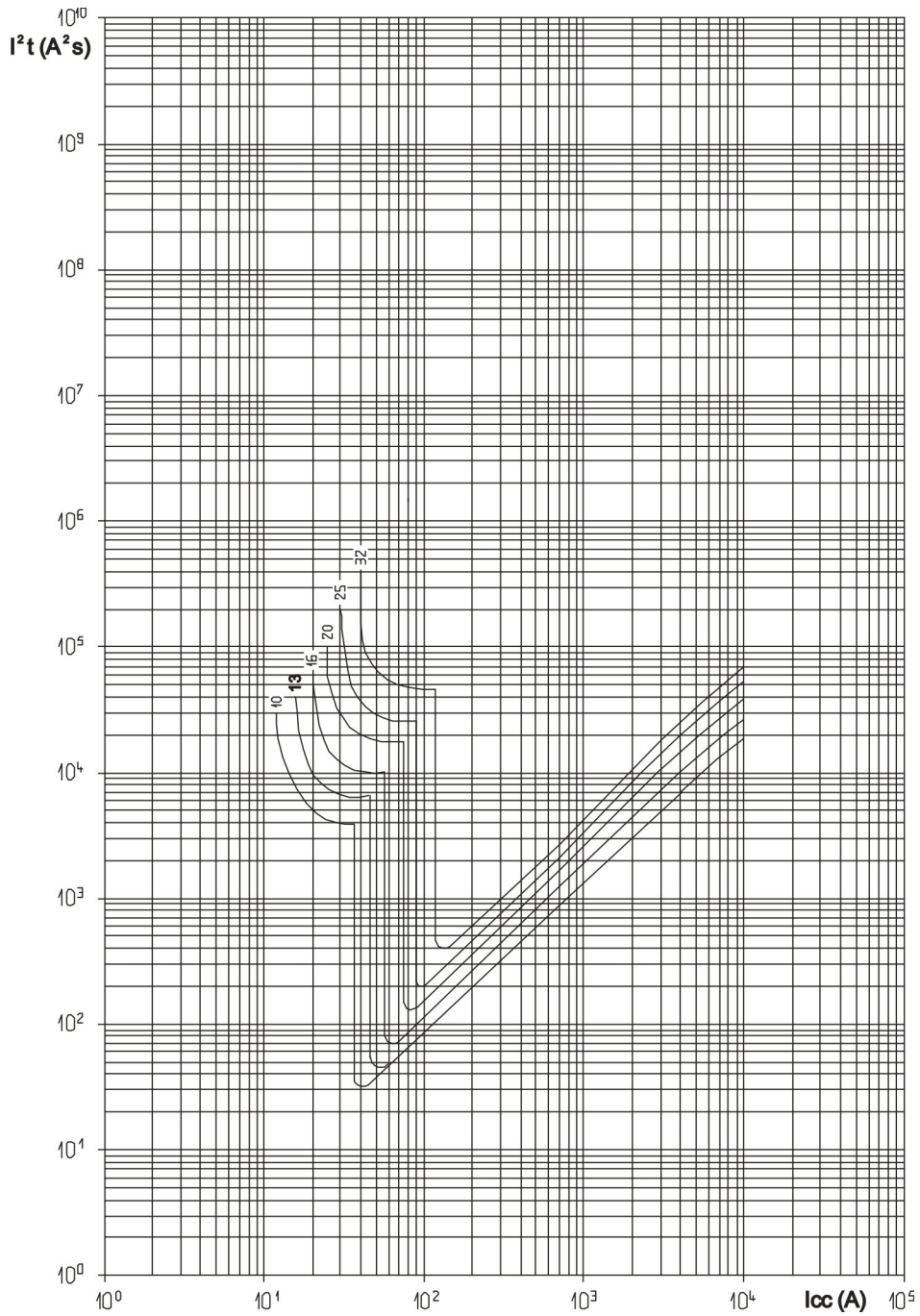

I_{cc} = Prospective short-circuit symmetrical current (rms value in kA)

I^2t = Limited thermal stress (in A^2s)

7. CURVES (continued)

Thermal stress limiting curves:

. C curve 4-pole RCBO

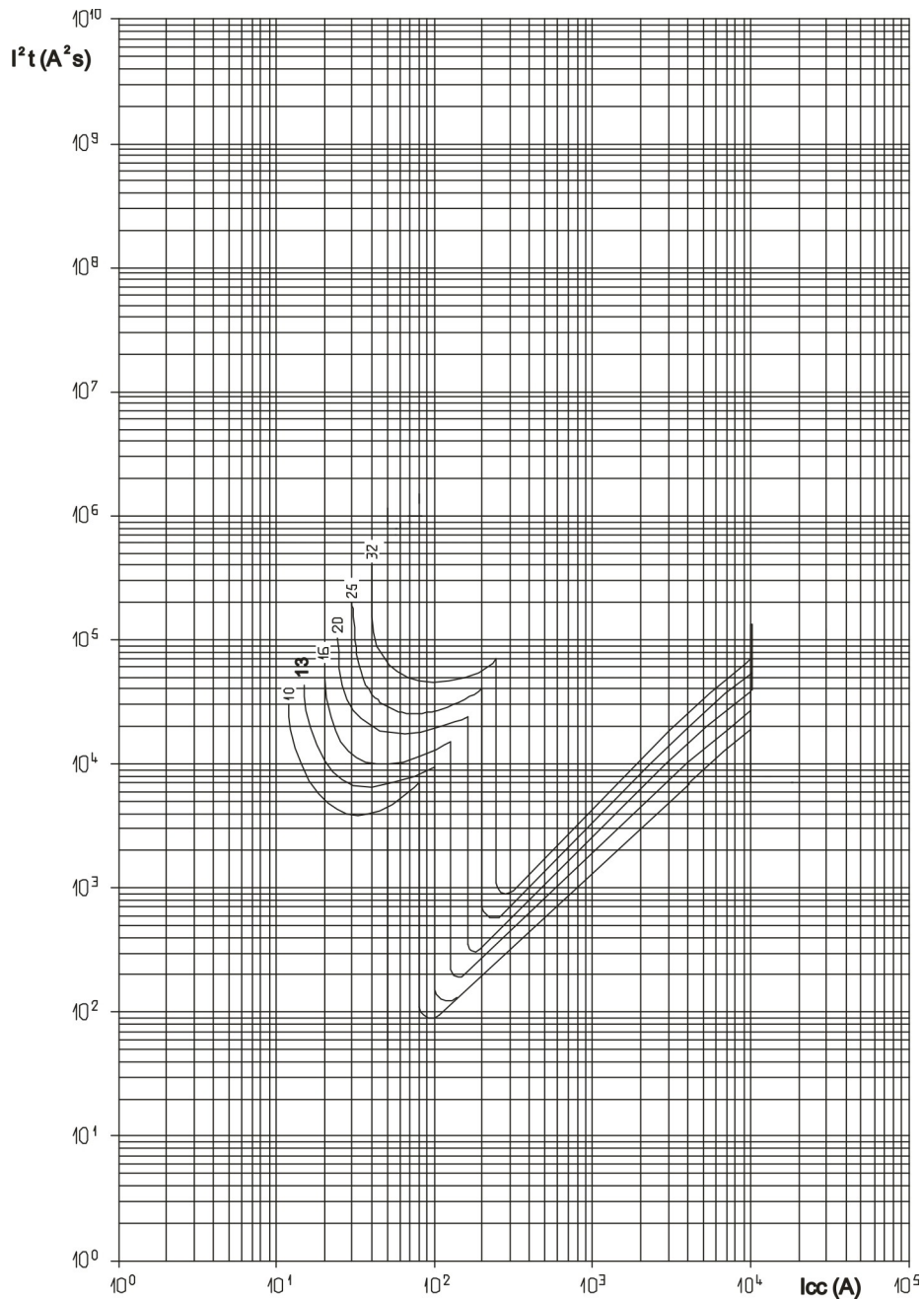

I_{cc} = Prospective short-circuit symmetrical current (rms value in kA)

I²t = Limited thermal stress (in A²s)

7. CURVES (continued)

Tripping current curves:

. Tripping time curve depending on the value of the fault current:

AC TYPE

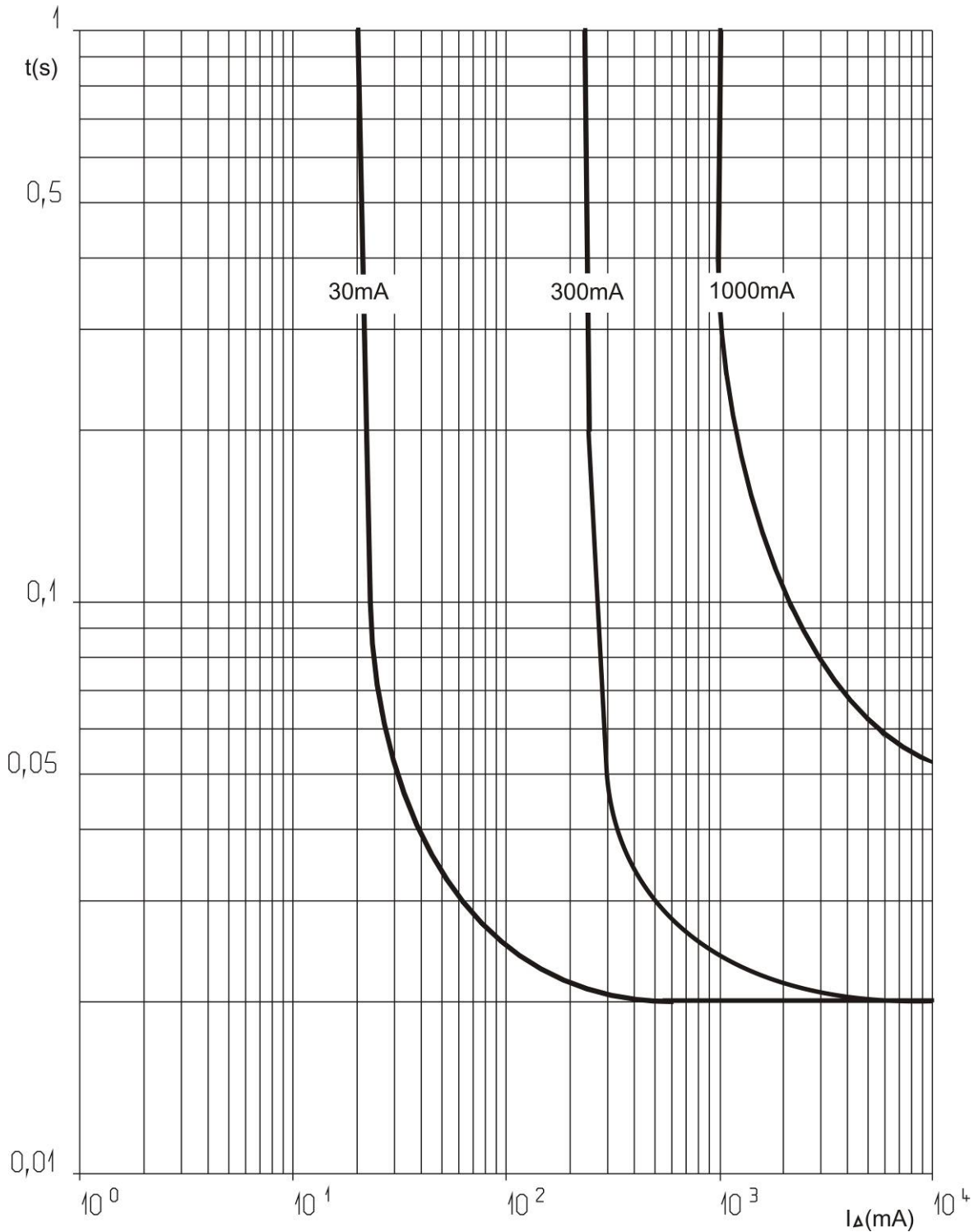

7. CURVES (continued)

Tripping current curves:

. Tripping time curve depending on the value of the fault current:

A TYPE

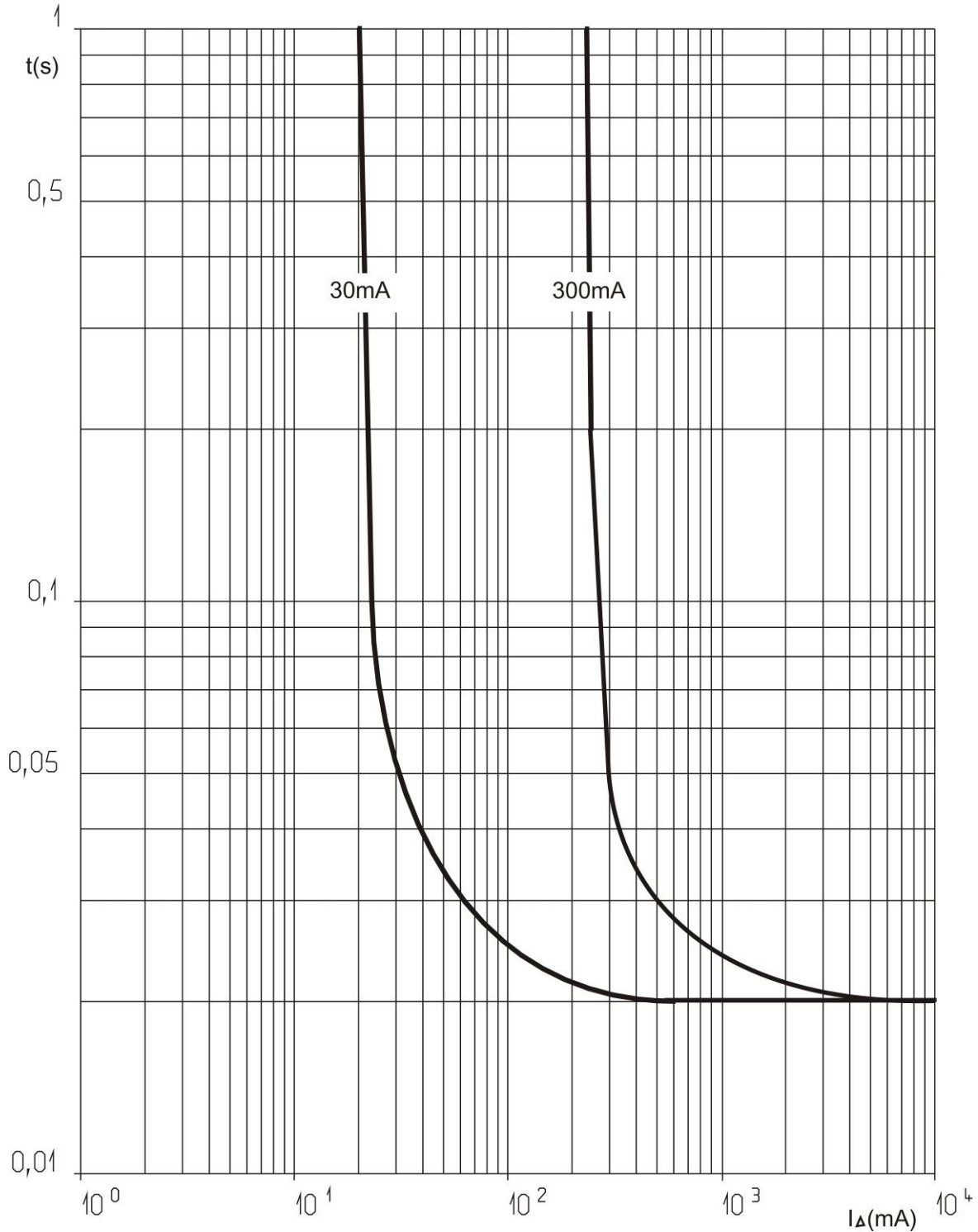

7. CURVES (continued)

Tripping current curves:

. Tripping time curve depending on the value of the fault current:

F TYPE

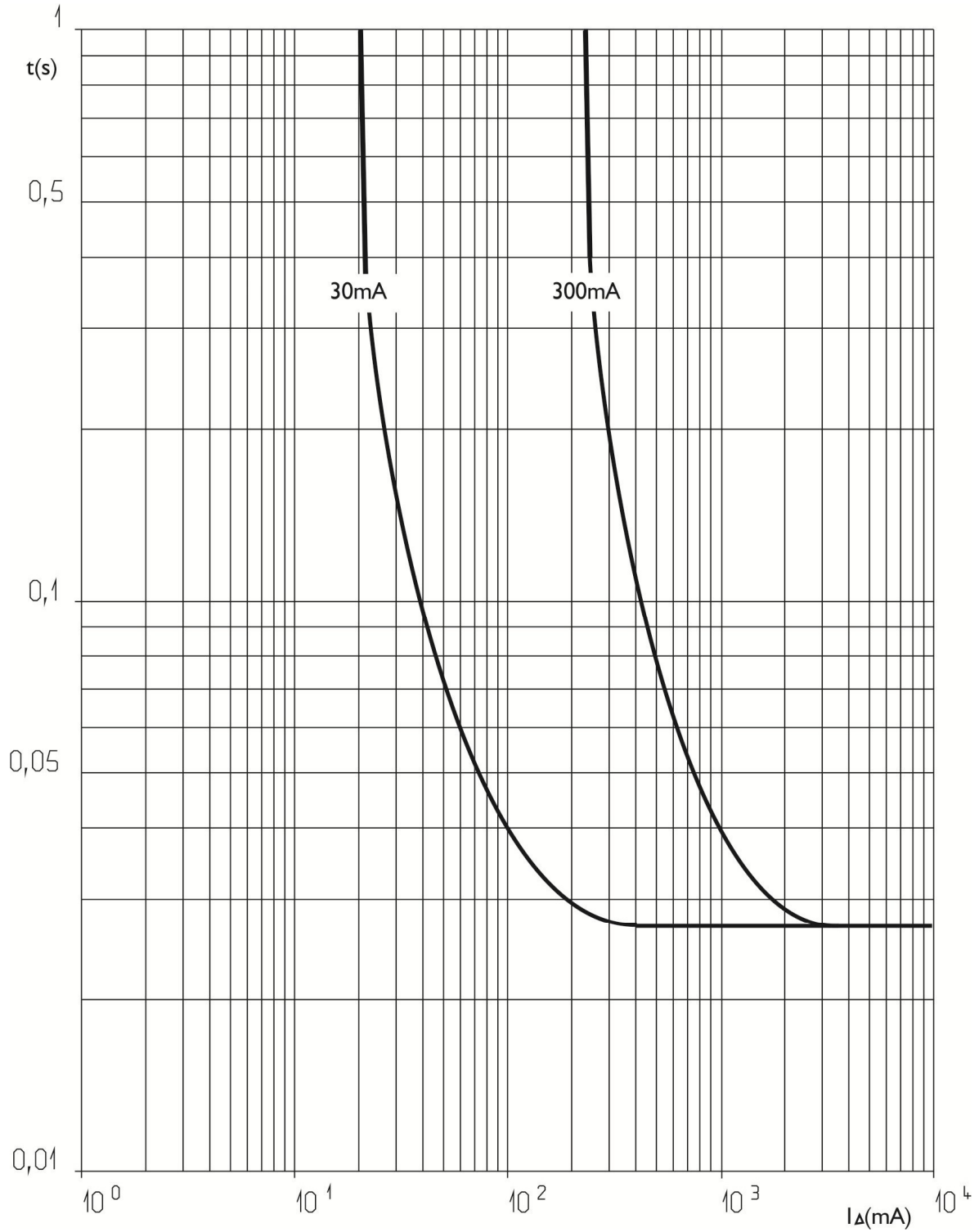

8. AUXILIARIES AND ACCESSORIES

Wiring accessories:

- . Supply busbar:
- HX³ 4-pole universal supply busbar (Cat. No. 4 049 54, 9 55)
- . Connection Terminals for aluminium cable with max. 50 mm² cross-section (Cat. No. 4 063 10)
- . Sealable screw cover (Cat. No. 4 063 04)

Signalling auxiliaries:

- . Auxiliary contact (0.5 module, Cat. No. 4 062 58)
- . Fault signalling contact (0.5 module, Cat. No. 4 062 60)
- . Auxiliary contact that can be changed into fault signalling contact (0.5 module, Cat. No. 4 062 62)
- . Auxiliary contact + fault signalling contact that can be changed into 2 auxiliary contacts (1 module, Cat. No. 4 062 66)

Control auxiliaries:

- . Shunt trip (1 module, Cat. No. 4 062 76, 2 78)
- . Undervoltage release (1 module, Cat. No. 4 062 80, 82)
- . Stand-alone release for N/C push-button (1.5 module, Cat. No. 4 062 87)

Motor driven control modules:

- Motor-driven control module (1 module, Cat. No. 4 062 91)
- . Motor-driven control module with integrated automatic reset (2 modules, Cat. Nos. 4 062 93, 95)

Possible combinations of auxiliaries and RCBOs:

- . The auxiliaries are installed to the left of the RCBOs
- . Maximum number of auxiliaries = 3
- . Maximum number of 1 module signalling auxiliaries = 2
- . Maximum number of control auxiliaries (Cat. Nos. 4 062 76 to 4 062 87) = 1
- . The control auxiliary trip (Cat. Nos. 4 062 76 to 4 062 87) must mandatorily be placed to the left of the signalling auxiliaries (Cat. Nos. 4 062 58 to 4 062 66) where the auxiliaries from these 2 families are connected to the same RCBO

Sealing:

- . Possible in the open or closed positions

Locking options:

- . Via padlock 5 mm in diameter (Cat. No. 4 063 13) or padlock 6 mm in diameter (Cat. No. 227 97) and padlock support (Cat. No. 4 063 03)

Installation software:

- . XL PRO³

9. SAFETY

- . For your safety your electrical installation is equipped with residual current protection and this must be tested periodically. In the absence of any national regulations on the time period required for this, Legrand recommends that this test be carried out every month: press the "T" test button, the device should trip. Please call an electrician immediately if this does not happen as the safety level of your installation has been reduced
- . The presence of residual current protection does not remove the need to observe all the precautions associated with using electrical energy.