

Circuit breaker DX³ 10000 A / 16 kA up to 63A (1 module per pole)

Cat. N° (s) : 4 088 80 to 4 093 61



CONTENTS	PAGE
1. Description - Use	1
2. Range	1
3. Overall dimensions	1
4. Preparation - Connection	1
5. General Characteristics	2
6. Compliance and approvals	6
7. Curves	7
8. Auxiliaries and accessories	16
9. Use in direct current	16

1. DESCRIPTION - USE:

. Thermal-magnetic circuit breaker (MCB) with positive contact indication for control, protection against short-circuits and overloads, and isolation of electrical circuits.

Symbol:

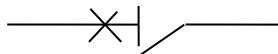

Technology:

. Energy limiting circuit-breaker
. 1 Module (17,8) per pole

2. RANGE

Polarity:

. 1P / 2P / 3P / 4P

Rated currents, In:

. 1 / 2 / 3 / 6 / 10 / 13 / 16 / 20 / 25 / 32 / 40 / 50 / 63A B and C curves.

Instantaneous tripping characteristics according to IEC/EN 60898-1:

. B type
. C type

Time-current characteristic according to IEC/EN 60898-1:

. Reference temperature: 30° C
. Non-tripping current (Int): 1,13 In.
. Tripping current (It): 1,45 In.

Instantaneous tripping characteristics according to IEC/EN 60947-2:

. B type = 4 In +/- 20%
. C type = 7 In +/- 20%

Time-current characteristic according to IEC/EN 60947-2:

. Reference temperature: 40° C
. Non-tripping current: 1,05 In.
. Tripping current: 1,3 In.

Breaking capacity and Rated voltage (50/60 Hz):

. 10000 A according to IEC/EN 60898-1
230/400 V~ and 400 V~

. 16 kA cat. A according to IEC/EN 60947-2
230 V ~ and 400 V~

3. OVERALL DIMENSIONS :

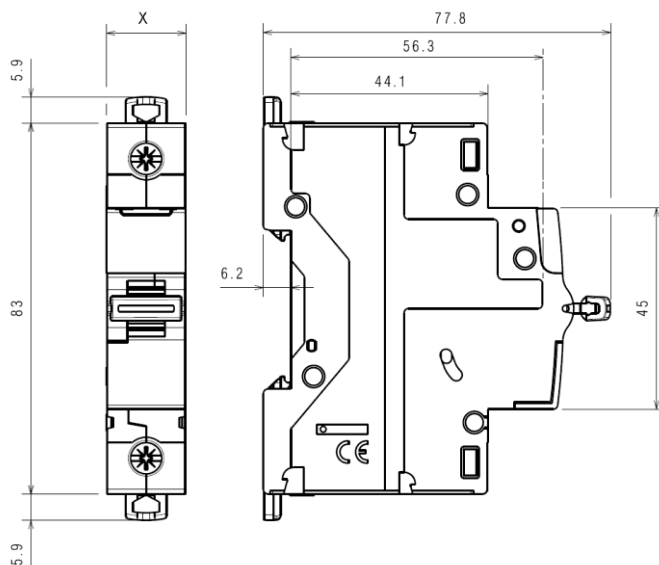

	X
1P	17.8 mm
2P	35.6 mm
3P	53.4 mm
4P	71.2 mm

4. PREPARATION - CONNECTION

Fixing:

. On symmetric rail EN/IEC 60715 or DIN 35 rail.

Operating positions:

. Vertical Horizontal Upside down On the side

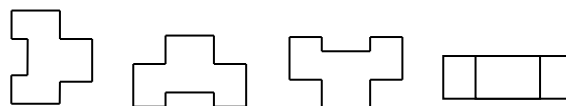

Supply:

. From the top or the bottom.

Circuit breaker DX³ 10000 A / 16 kA up to 63A (1 module per pole)

Cat. N° (s) : 4 088 80 to 4 093 61

4. PREPARATION – CONNECTION *(continued)*:

Connection:

. Inputs and outputs via screw terminals
The location of the terminals allows supplying by traditional HX³ pin busbar and fork busbar.

Terminal depth:

. 14 mm

Stripping length recommended:

. 11 mm

Screw head:

. Mixed, slotted and Pozidriv 2.

Recommended tightening torque:

. Recommended: 2.5 Nm.
. Min: 2 Nm. Max: 3 Nm.

Tools required:

. For the terminals: Pozidriv n° 2 or flat screwdriver 5,5 mm (6 mm maximum).
. For fixing: flat screwdriver 5,5 mm (6 mm maximum).

Connectable section:

	Copper cables	
	Without ferrule	With ferrule
Solid cable	1 x 1 mm ² to 6 mm ² 2 x 1 mm ² to 6 mm ²	-
Stranded	1 x 1,5 mm ² to 35 mm ² 2 x 1,5 mm ² to 16 mm ²	-
Flexible cable	1 x 1 mm ² to 25 mm ² 2 x 1 mm ² to 10 mm ²	1 x 1 mm ² to 25 mm ²

Aluminium cable with cross-section > 10 mm²: it is necessary to use the accessory with cat. N° 4 063 10.

Manual actuation of the MCB:

. Ergonomic 2-position handle
. "I-ON": Device closed
. "O-OFF": Device open

Contact status display:

. By marking of the handle
- "O-OFF" in white on a green background = contacts open
- "I-ON" in white on a red background = contacts closed

Labelling:

. Identification of the circuit by insertion of a label in the label holder.



5. GENERAL CHARACTERISTICS:

Marking on the front side:

- . By permanent ink pad printing:
 - Trade name: DX³
 - Tripping curve. [W]
 - Rated current (in A) [XX].
 - Icn in A rated breaking capacity in accordance with EN/IEC 60898-1 (in a box) [####]
 - Limiting class "3" (in a square) only B and C curves.
 - Icu in kA extreme breaking capacity in accordance with IEC/EN 60947-2
 - Mark: Legrand.
 - Redline.
 - Line + dot logo.
 - Reference. [YYYY YY]



Marking on the side:

- Production information and COPY-TRACER (The Copy-tracer number ensures that a product is traced and guarantees its production quality).
Info: <http://www.legrand-copytracer.com/>

Short-circuit breaking capacity:

. Alternate current 50/60Hz, single-phase or three-phase network, in accordance with standard: IEC/EN 60898-1

Un		1P	2P	3P / 4P
110 V~	Icn	16000 A	25000 A	-
230 V~		10000 A*	16000 A	16000 A
400 V~		-	10000 A*	10000 A*

*= certified according to IEC/EN 60898-1

Icn	Ics
Icn ≤ 6000 A	100% Icn
6000 A < Icn ≤ 10000 A	75% Icn
Icn > 10000 A	50% Icn

. Alternate current 50/60Hz, single-phase or three-phase network, in accordance with standard: IEC/EN 60947-2

Un		1P / 1P+N	2P	3P / 4P
110 V~	Icu	25 kA	50 kA	-
230V~		16 kA*	32 kA	32 kA
400V~		-	16 kA*	16 kA*

*= certified according to IEC/EN 60947-2

Un	Ics	75% of Icu	75% of Icu	75% of Icu
110 V~	Ics	75% of Icu	75% of Icu	75% of Icu
230V~				
400V~				

Circuit breaker DX³ 10000 A / 16 kA up to 63A (1 module per pole)

Cat. N° (s) : 4 088 80 to 4 093 61

5. GENERAL CHARACTERISTICS (continued):

Short-circuit breaking capacity on one pole:

- . Three-phase network 400 V~
 - in TN neutral system, I_{cn1} = 16 kA
 - in IT distribution system, I_{it} = 4 kA
- . Three-phase network 230 V~
 - in TN neutral system, I_{cn1} = 32 kA
 - in IT distribution system, I_{it} = 8 kA

Minimum operating voltage:

- . 12 V.

Pulse rated voltage:

- . U_{imp} = 4 kV

Insulation rated voltage:

- . U_i = 500 V

Pollution degree:

- . 2 according to IEC/EN 60898-1.
- . 3 according to IEC/EN 60947-2.

Resistance to environmental conditions:

- . according to IEC/EN 60068-2-30 (55° C, 90% RH)
- . severity 2 (marine environment) in accordance with standard IEC/EN 60068-2-52.

Dielectric strength at power frequency:

- . 2500 V

Operation at 400Hz:

- . The instantaneous tripping threshold increase by 45%.

Force necessary to close and to open by the handle:

- . 0.1 Nm per pole to close.
- . 0.075 Nm per pole to open.

Mechanical and electrical endurance:

- . 20000 operations without load.
- . 10000 operations with load (under I_n*cos φ = 0,9).

Enclosure material:

- . Glow-wire test at 960° C according to IEC/EN 60898-1 and IEC 60695-2-12
- . Halogens-free

Average weight per pole:

- . 0,150 kg.

5. GENERAL CHARACTERISTICS (continued):

Volume when packed:

	Volume (dm ³)
Single pole	0,163
Double pole	0,334
Triple pole / Four pole	0,680

Ambient operating temperature:

- . Min. = -25° C. Max. = +70° C

Ambient storage temperature:

- . Min. = -40° C. Max. = +70° C

Degree of protection:

- . Degree of protection in the terminals area: IP 20, (in accordance with standards IEC/EN 60898-1 and IEC/EN 60529).
- . Degree of protection of the remaining parts: IP 40 (in accordance with standards IEC/EN 60529).
- . Protection index against mechanical shocks: IK 02 (in accordance with standards IEC/EN 62262).

Sinusoidal vibration resistance in accordance with IEC/EN 60068-2-6:

- . Axis: x, y, z.
- . Frequency range: 5 ÷ 100 Hz; duration 90 minutes
- . Displacement (5 ÷ 13,2 Hz): 1mm
- . Acceleration (13,2 ÷ 100 Hz): 0,7g (g=9,81 m/s²)

Recognition:

- . Recognition of the circuits by label in the "label holder" on the front-side of m.c.b.

Power dissipated per pole (W) :

- . Type B and C Circuit-breakers

I _n	1 A	2 A	3 A	6 A	10 A	16 A	20 A
1P ÷ 4P	2	2	2	1,1	1,8	2	2,2

I _n	25 A	32 A	40 A	50A	63A
1P ÷ 4P	2,7	3,2	4	4,5	5,5

- . Impedance per pole (Ω) = $\frac{P \text{ dissipated}}{I_n^2}$

Circuit breaker DX³ 10000 A / 16 kA up to 63A (1 module per pole)

Cat. N° (s) : 4 088 80 to 4 093 61

5. GENERAL CHARACTERISTICS (continued):

Derating of circuit-breakers according to ambient temperature:

. The nominal characteristics of a circuit breaker are modified according to the ambient temperature inside the cabinet or the enclosure where the circuit breaker is located.

. Reference temperature: 30° C in accordance with EN/IEC 60898-1

In (A)	Ambient Temperature / In									
	- 25° C	- 10° C	0° C	10° C	20° C	30° C	40° C	50° C	60° C	70° C
0.5	0.62	0.6	0.57	0.55	0.52	0.5	0.47	0.42	0.40	0.38
1	1.5	1.4	1.3	1.2	1.1	1	0.9	0.8	0.7	0.6
1.5	1.9	1.8	1.7	1.7	1.6	1.5	1.5	1.4	1.4	1.3
2	2.8	2.6	2.5	2.3	2.2	2	2	1.9	1.8	1.7
3	3.8	3.6	3.5	3.3	3.2	3.0	2.9	2.8	2.7	2.6
3.5	4.5	4.2	4.0	3.9	3.7	3.5	3.4	3.3	3.2	3.1
5	6.4	6.0	5.8	5.5	5.3	5.0	4.8	4.7	4.5	4.6
6	7.5	7.0	6.6	6.4	6.2	6.0	5.8	5.6	5.4	5.3
10	12.5	11.5	11.1	10.7	10.3	10.0	9.7	9.3	9.0	8.7
13	16.3	15.0	14.3	13.9	13.4	13.0	12.6	12.1	11.7	11.3
16	20.0	18.7	18.0	17.3	16.6	16.0	15.4	14.7	14.1	13.5
20	25.0	23.2	22.4	21.6	20.8	20.0	19.2	18.4	17.6	16.8
25	31.5	29.5	28.3	27.2	26.0	25.0	24.0	22.7	21.7	20.7
30	38.3	36.0	34.5	33.0	31.5	30.0	28.8	27.3	26.1	24.9
32	41.0	37.8	36.5	34.9	33.3	32.0	30.7	29.1	27.8	26.5
40	51.0	48.0	46.0	44.0	42.0	40.0	38.0	36.0	34.0	32.0
50	64.0	60.0	57.5	55.0	52.5	50.0	47.5	45.0	42.5	40.0
63	80.6	75.6	72.5	69.9	66.1	63.0	59.8	56.1	52.9	49.7

. Reference temperature: 40° C in accordance with EN/IEC 60947-2

In (A)	Ambient Temperature / In									
	- 25° C	- 10° C	0° C	10° C	20° C	30° C	40° C	50° C	60° C	70° C
0.5	0.64	0.62	0.6	0.57	0.55	0.52	0.5	0.47	0.42	0.40
1	1.6	1.5	1.4	1.3	1.2	1.1	1	0.9	0.8	0.7
1.5	2.0	1.9	1.8	1.7	1.7	1.6	1.5	1.5	1.4	1.4
2	3.0	2.8	2.6	2.5	2.3	2.2	2	2	1.9	1.8
3	4.1	3.8	3.6	3.5	3.3	3.2	3.0	2.9	2.8	2.7
3.5	4.9	4.5	4.2	4.0	3.9	3.7	3.5	3.4	3.3	3.2
5	7.0	6.4	6.0	5.8	5.5	5.3	5.0	4.8	4.7	4.5
6	8.2	7.5	7.0	6.6	6.4	6.2	6.0	5.8	5.6	5.4
10	14.0	12.5	11.5	11.1	10.7	10.3	10.0	9.7	9.3	9.0
13	18.2	16.3	15.0	14.3	13.9	13.4	13.0	12.6	12.1	11.7
16	21.9	20.0	18.7	18.0	17.3	16.6	16.0	15.4	14.7	14.1
20	27.7	25.0	23.2	22.4	21.6	20.8	20.0	19.2	18.4	17.6
25	34.5	31.5	29.5	28.3	27.2	26.0	25.0	24.0	22.7	21.7
30	41.7	38.3	36.0	34.5	33.0	31.5	30.0	28.8	27.3	26.1
32	45.8	41.0	37.8	36.5	34.9	33.3	32.0	30.7	29.1	27.8
40	55.5	51.0	48.0	46.0	44.0	42.0	40.0	38.0	36.0	34.0
50	70.0	64.0	60.0	57.5	55.0	52.5	50.0	47.5	45.0	42.5
63	88.1	80.6	75.6	72.5	69.9	66.1	63.0	59.8	56.1	52.9

Circuit breaker DX³ 10000 A / 16 kA up to 63A (1 module per pole)

Cat. N° (s) : 4 088 80 to 4 093 61

5. GENERAL CHARACTERISTICS *(continued)*:

Derating of MCB for use with fluorescent lights:

Ferromagnetic and electronic ballasts have a high inrush current for a short time. These currents can cause the tripping of circuit breakers. At the time of the installation, it should take into account the maximum number of ballasts per circuit breaker that the manufacturers of lamps and ballasts indicate in their catalogues.

Influence of the altitude:

	≤2000 m	3000 m	4000 m
Dielectric holding	3000 V	2500 V	2000 V
Max operational Voltage	400 V	400 V	400 V
Derating at 30° C	none	none	none

Derating of MCBs function of the number of devices side by side:

When several MCBs are juxtaposed and operate simultaneously, the thermal evacuation of the poles is limited. This results in an increase in operating temperature of the circuit breakers which can cause unwanted tripping. It is recommended to apply the following coefficients to the rated currents.

Number of circuit breakers side by side	Coefficient
2 - 3	0.9
4 - 5	0.8
6 - 9	0.7
≥ 10	0.6

These values are given by the recommendation of IEC/EN 60439-1.

To avoid using these coefficients, it is necessary to allow a good ventilation and to separate the devices with 0.5 module spacing elements (cat. N° 4 063 07).

Circuit breaker DX³ 10000 A / 16 kA up to 63A (1 module per pole)

Cat. N° (s) : 4 088 80 to 4 093 61

6. CONFORMITIES AND APPROVALS

In accordance with standards:

- . IEC/EN 60898-1 with 10000 A breaking capacity
- . IEC/EN 60947-2 with 16 kA breaking capacity
- . EU guidelines: 2014/35/EU + 2014/30/EU
- . Legrand circuit-breakers can be used under the conditions of use as defined by IEC/EN 60947.
- . The performance of circuit-breakers can be influenced by particular climates: hot dry, cold dry, hot humid, salt fog atmosphere

Classification according to Annex Q (standard IEC/EN 60947-1):

- . Category C with a range test temperature -25 ° C / +70 ° C
- . Salt fog atmosphere according IEC 60068-2-52

Environment respect – Compliance with EU directives:

- . Compliance with Directive 2011/65/EU of 08/06/11 (RoHS) and subsequent modifications and integrations.

Precious metal:

- . Silver: 0,04 g per pole $I_n \leq 16$ A; 0.08 g per pole $I_n \geq 20$ A
- . No gold

Packaging:

- . Design and manufacture of packaging in accordance with Directive 94/62/EC

Circuit breaker DX³ 10000 A / 16 kA up to 63A (1 module per pole)

Cat. N° (s) : 4 088 80 to 4 093 61

7. CHARACTERISTIC CURVES

Limiting current curve: circuit breakers curves B, C

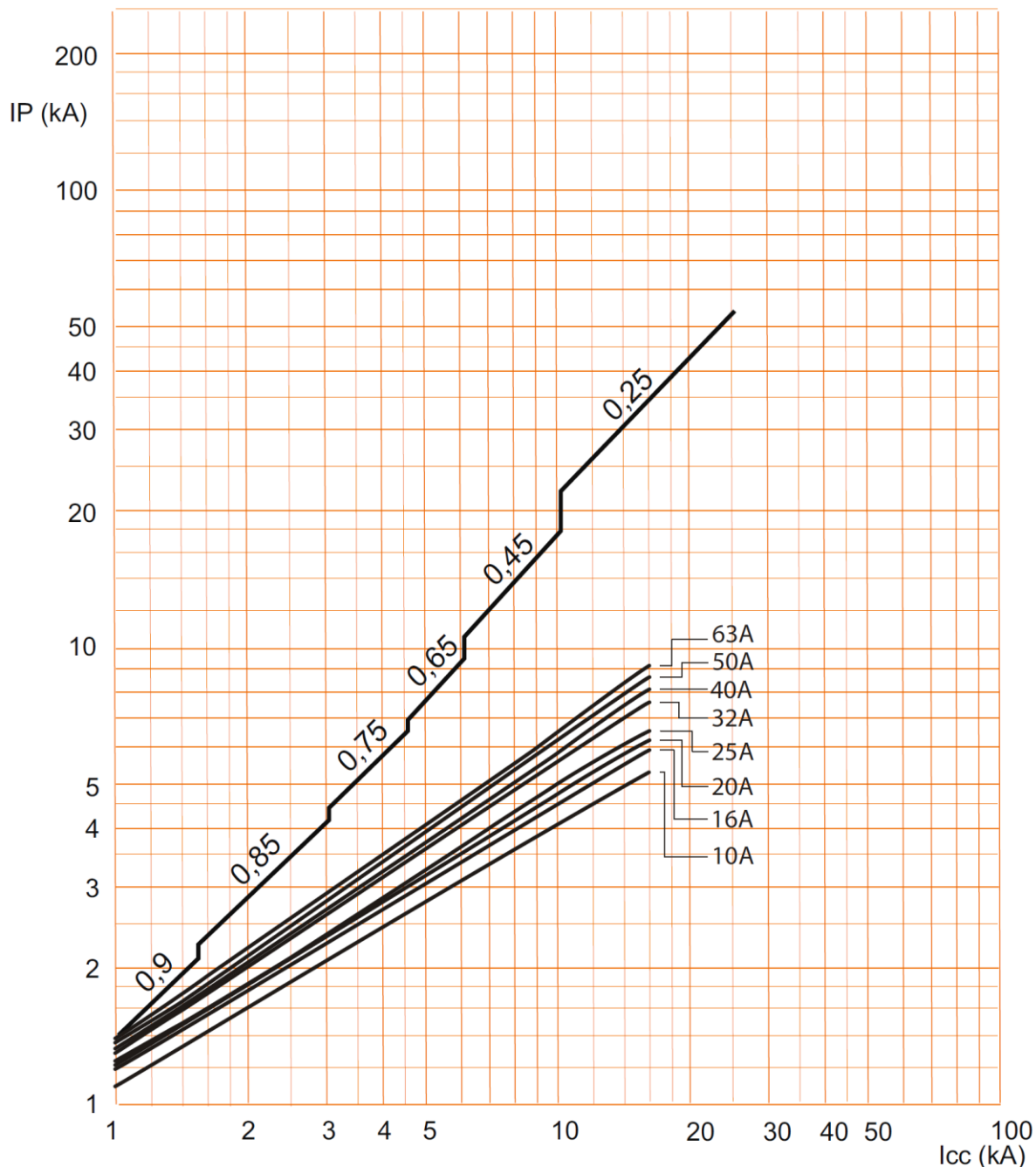

. I_{cc} = Square value of symmetric component of the short circuit current (kA).

. IP = Max peak value (kA)

Circuit breaker DX³ 10000 A / 16 kA up to 63A (1 module per pole)

Cat. N° (s) : 4 088 80 to 4 093 61

7. CHARACTERISTIC CURVES *(continued)*

Operating characteristic of circuit breakers curve B:

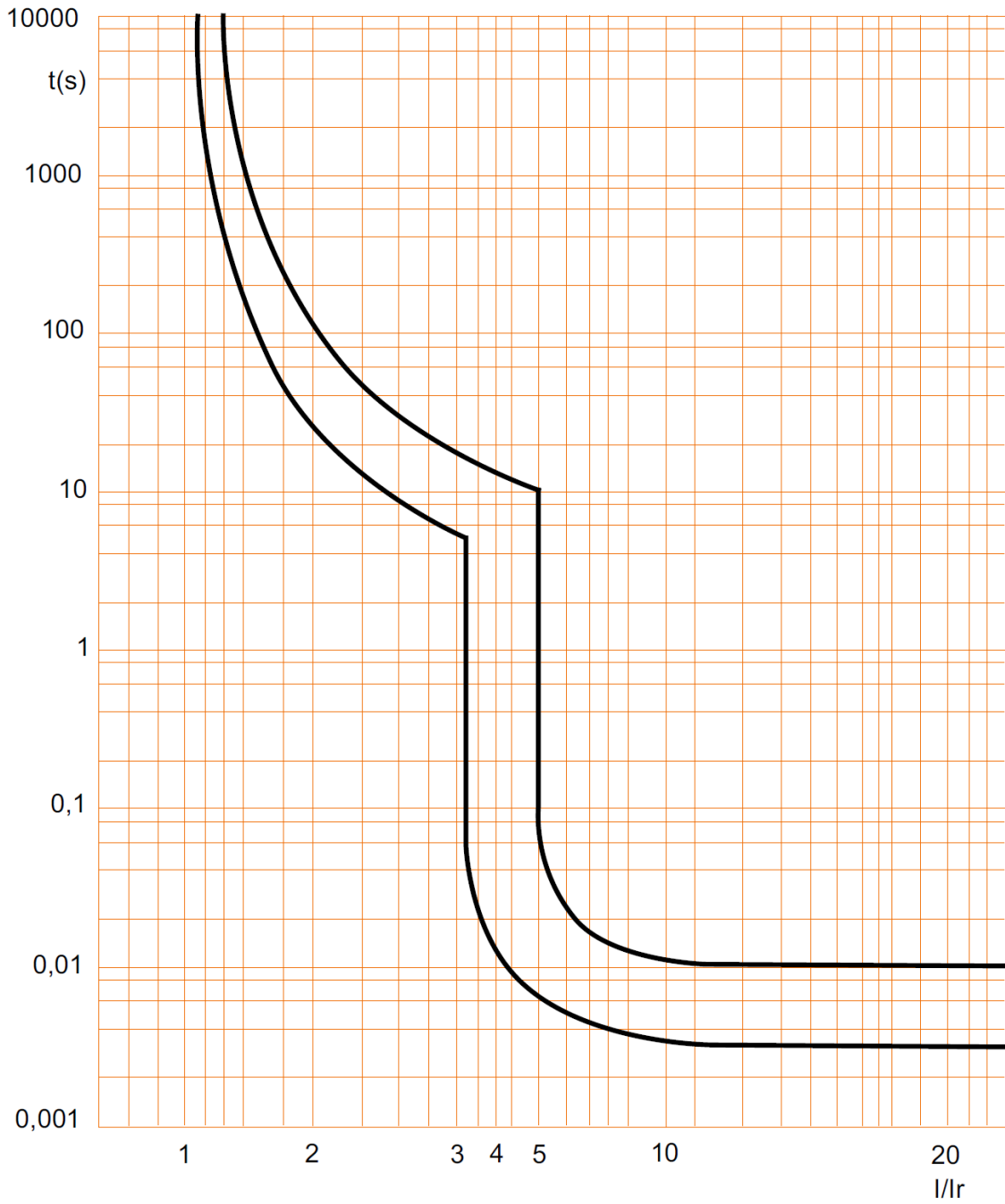

Circuit breaker DX³ 10000 A / 16 kA up to 63A (1 module per pole)

Cat. N° (s) : 4 088 80 to 4 093 61

7. CHARACTERISTIC CURVES (continued)

. Limiting thermal energy curve of circuit breakers curve B, 2P (230V~ / 50Hz):

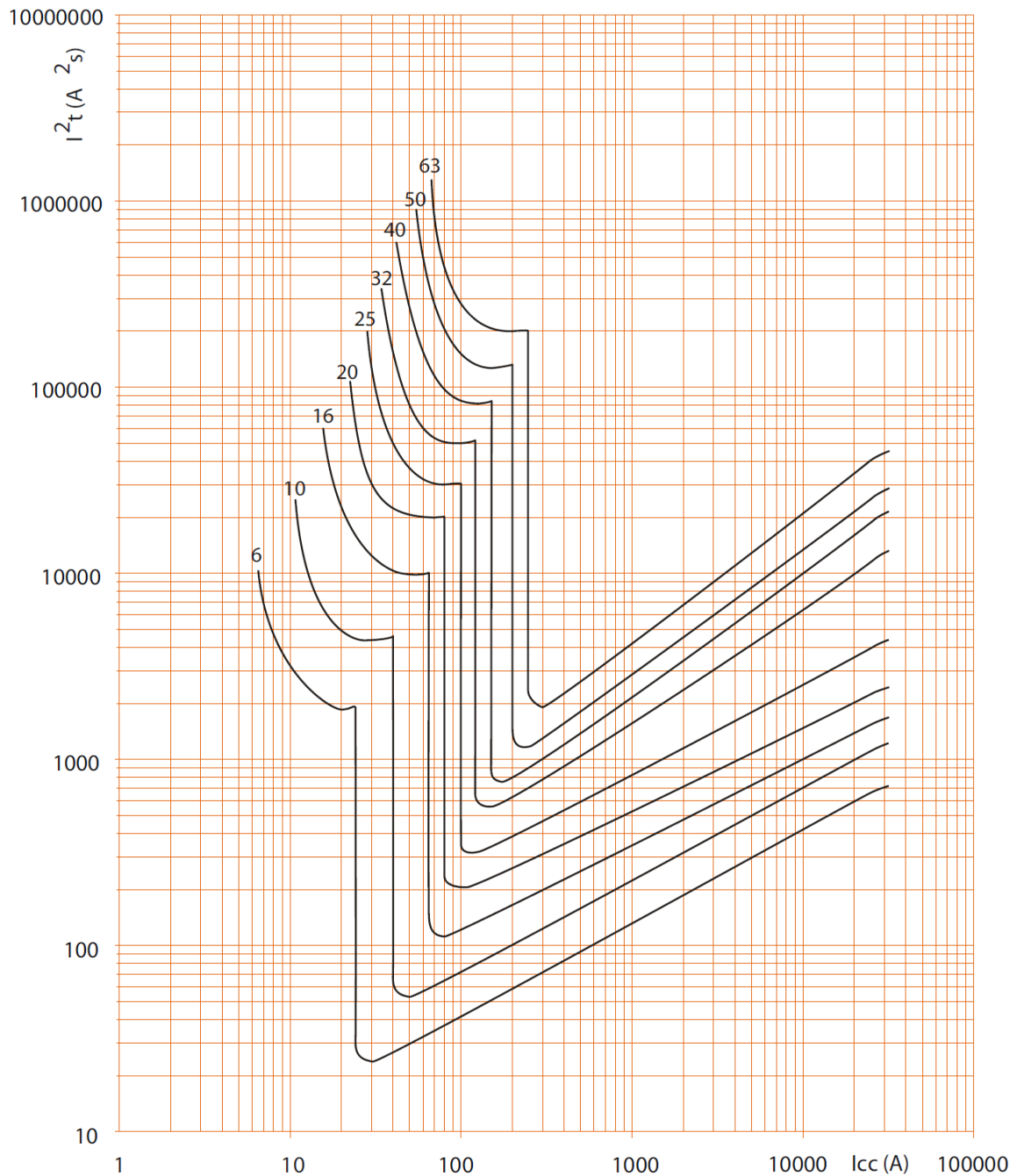

. I_{cc} = Square value of symmetric component of the short circuit current (kA).

. I^2t = Thermal energy limited (A^2s).

Circuit breaker DX³ 10000 A / 16 kA up to 63A (1 module per pole)

Cat. N° (s) : 4 088 80 to 4 093 61

7. CHARACTERISTIC CURVES (continued)

. Limiting thermal energy curve of circuit breakers curve B, 2P (400V~ / 50Hz) :

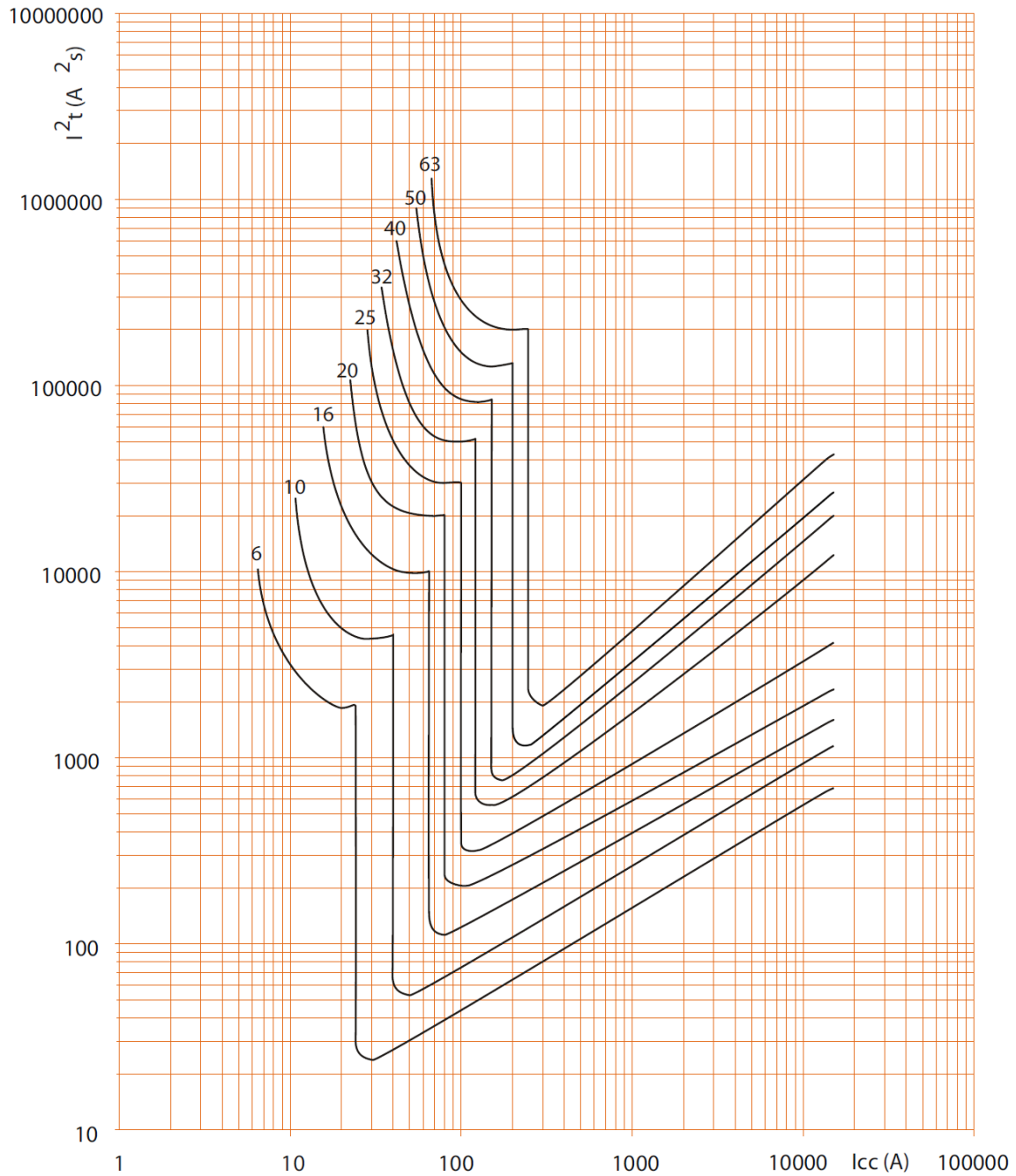

. Icc = Square value of symmetric component of the short circuit current (kA).
. I²t = Thermal energy limited (A²s).

Circuit breaker DX³ 10000 A / 16 kA up to 63A (1 module per pole)

Cat. N° (s) : 4 088 80 to 4 093 61

7. CHARACTERISTIC CURVES (continued)

. Limiting thermal energy curve of circuit breakers curve B, 1P / 3P / 4P (400V~ / 50Hz) :

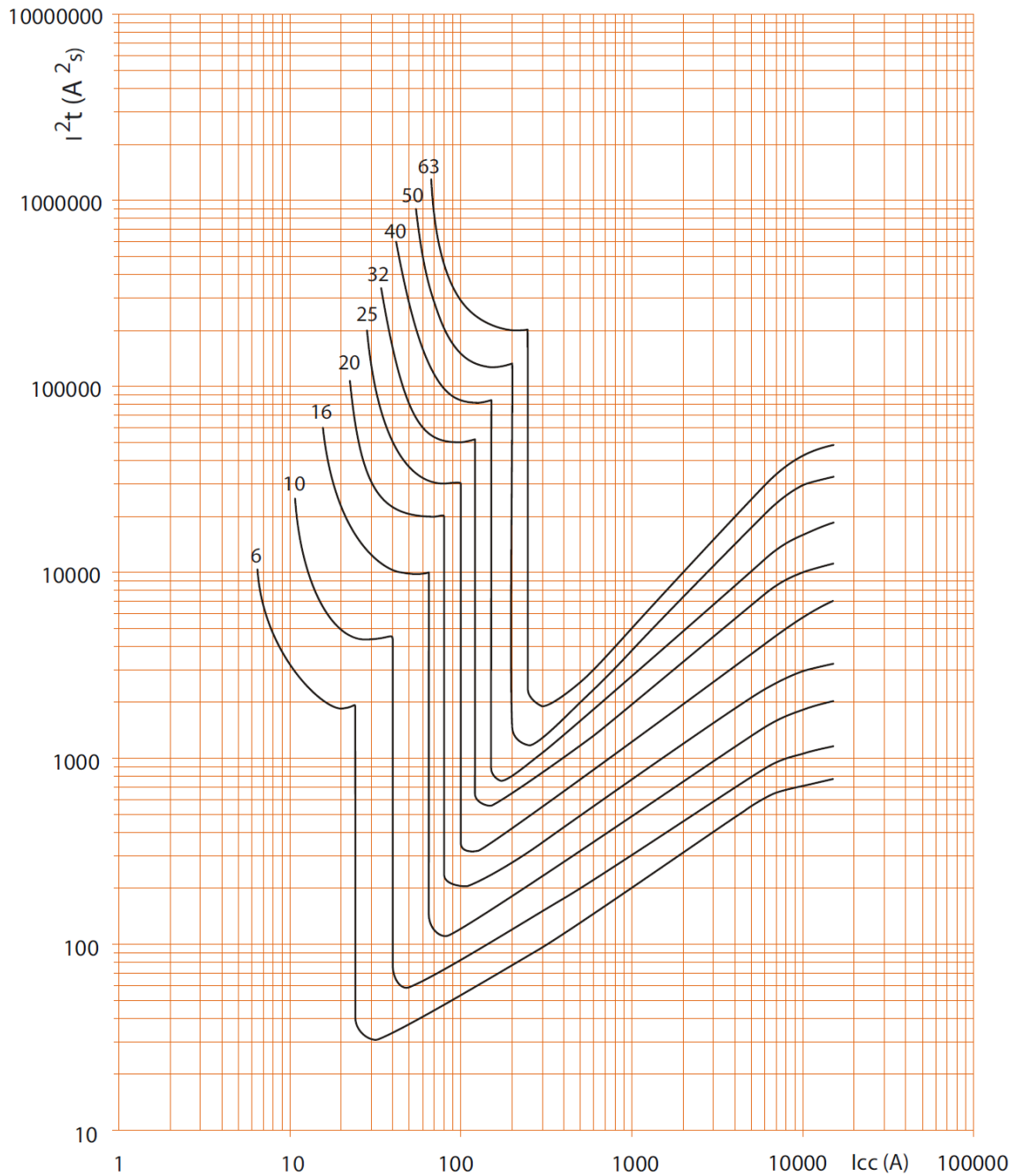

. I_{cc} = Square value of symmetric component of the short circuit current (kA).
. I^2t = Thermal energy limited (A^2s).

Circuit breaker DX³ 10000 A / 16 kA up to 63A (1 module per pole)

Cat. N° (s) : 4 088 80 to 4 093 61

7. CHARACTERISTIC CURVES *(continued)*

Operating characteristic of circuit breakers curve C :

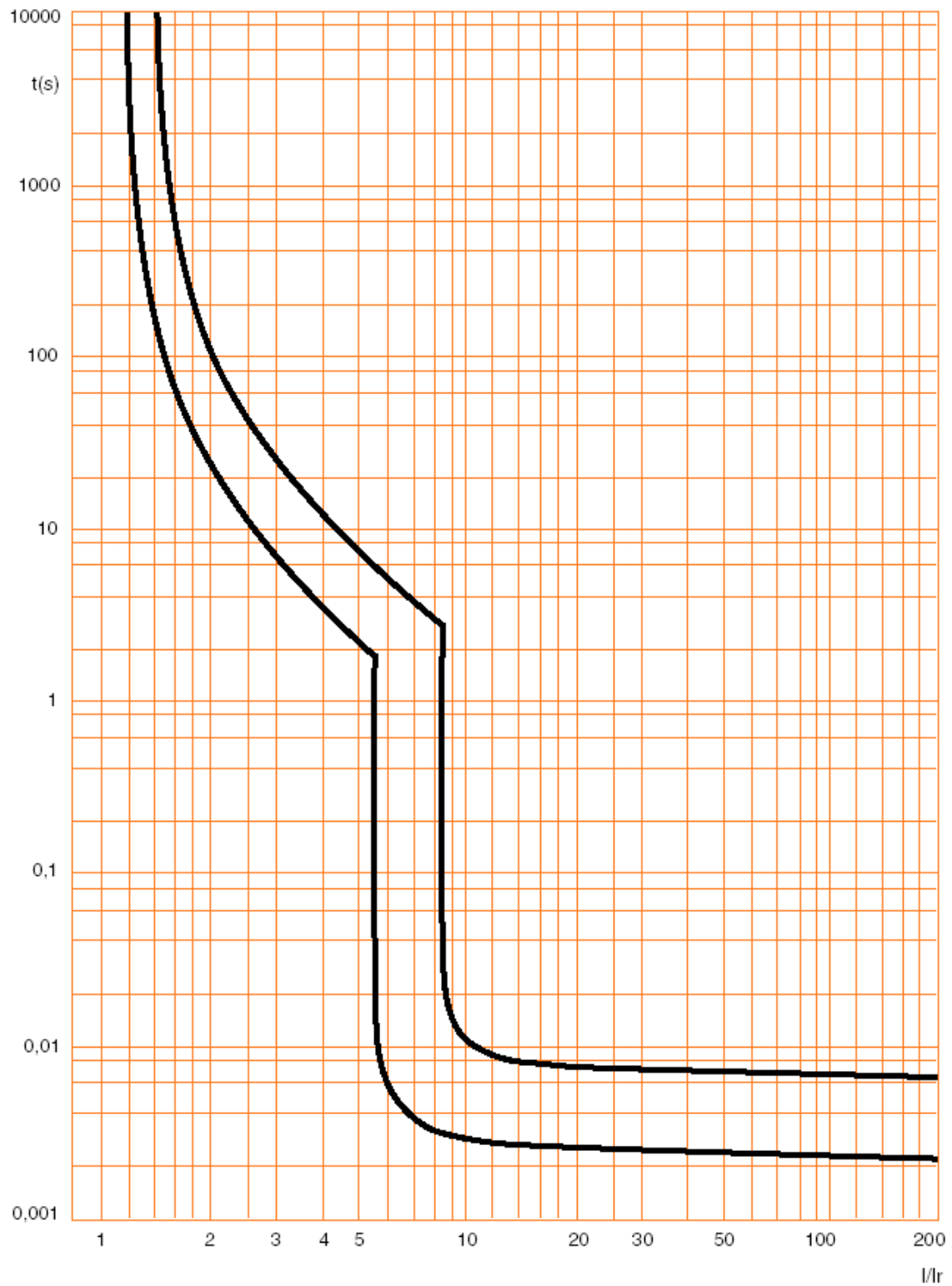

Circuit breaker DX³ 10000 A / 16 kA up to 63A (1 module per pole)

Cat. N° (s) : 4 088 80 to 4 093 61

7. CHARACTERISTIC CURVES (continued)

. Limiting thermal energy curve of circuit breakers curve C, 2P (230V~ / 50Hz) :

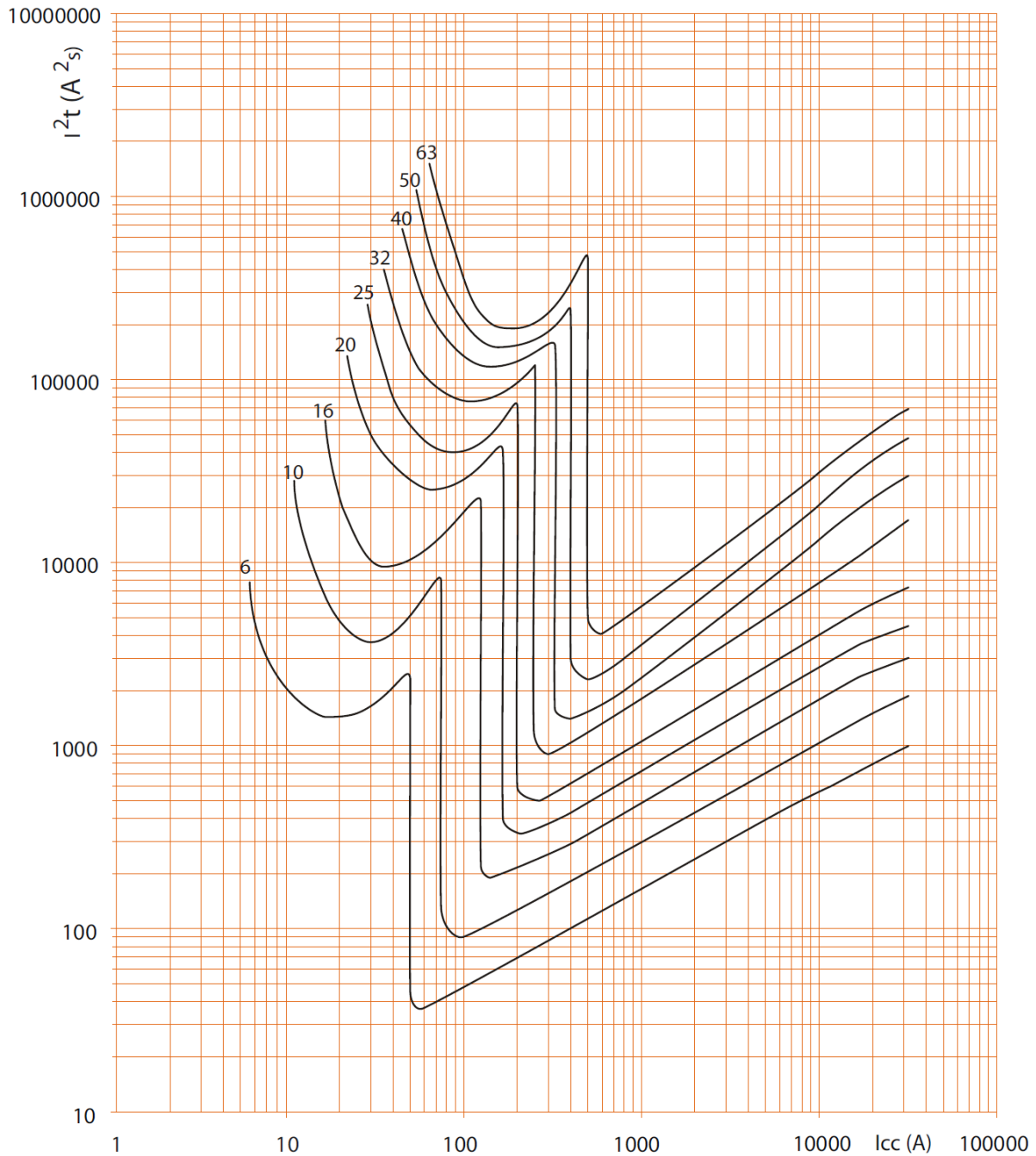

. I_{cc} = Square value of symmetric component of the short circuit current (kA).

. I^2t = Thermal energy limited (A^2s).

Circuit breaker DX³ 10000 A / 16 kA up to 63A (1 module per pole)

Cat. N° (s) : 4 088 80 to 4 093 61

7. CHARACTERISTIC CURVES (continued)

. Limiting thermal energy curve of circuit breakers curve C, 2P (400V~ / 50Hz) :

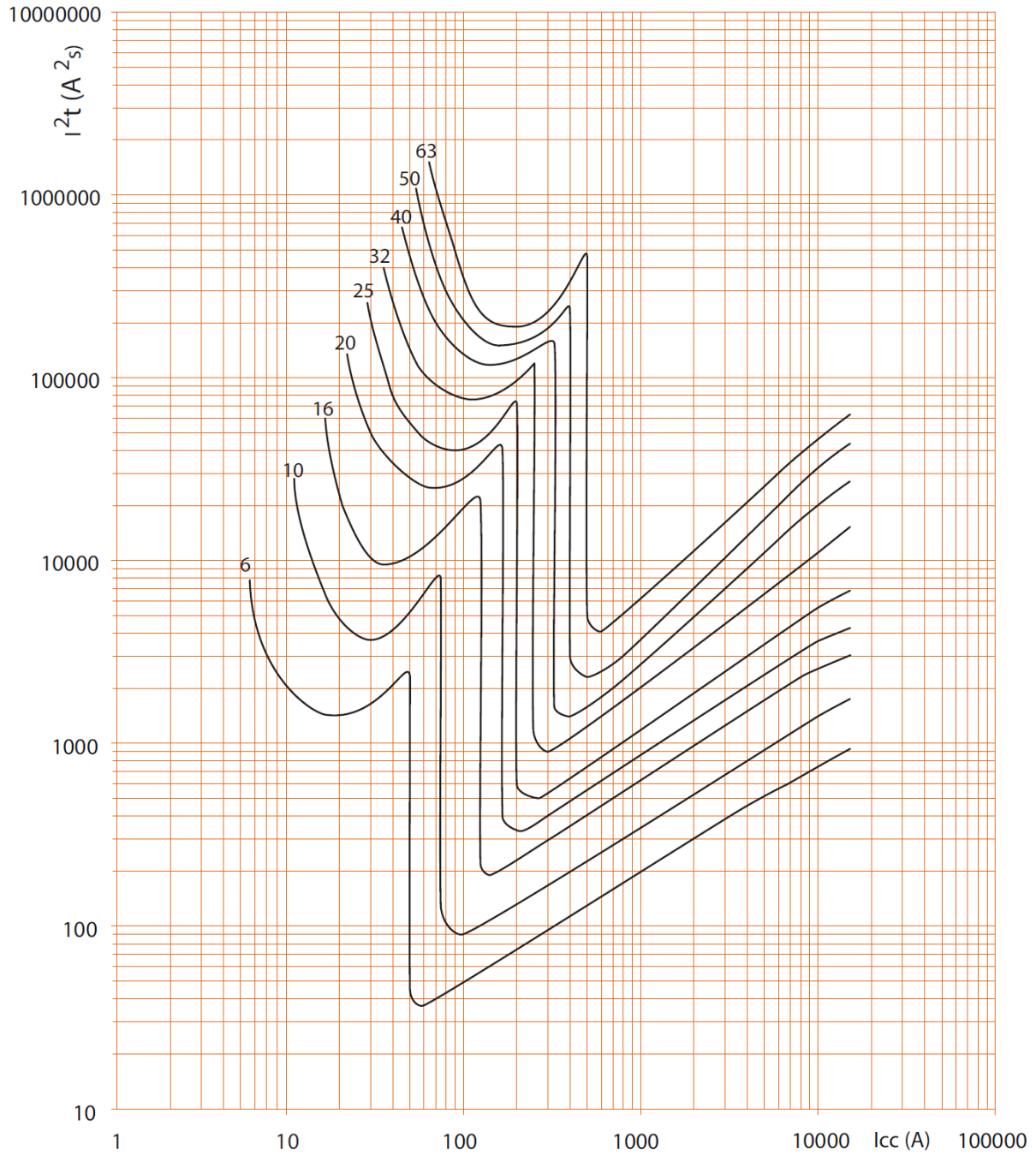

. I_{cc} = Square value of symmetric component of the short circuit current (kA).

. I^2t = Thermal energy limited (A^2s).

Circuit breaker DX³ 10000 A / 16 kA up to 63A (1 module per pole)

Cat. N° (s) : 4 088 80 to 4 093 61

7. CHARACTERISTIC CURVES (continued)

. Limiting thermal energy curve of circuit breakers curve C, 1P / 3P / 4P (400V~ / 50Hz) :

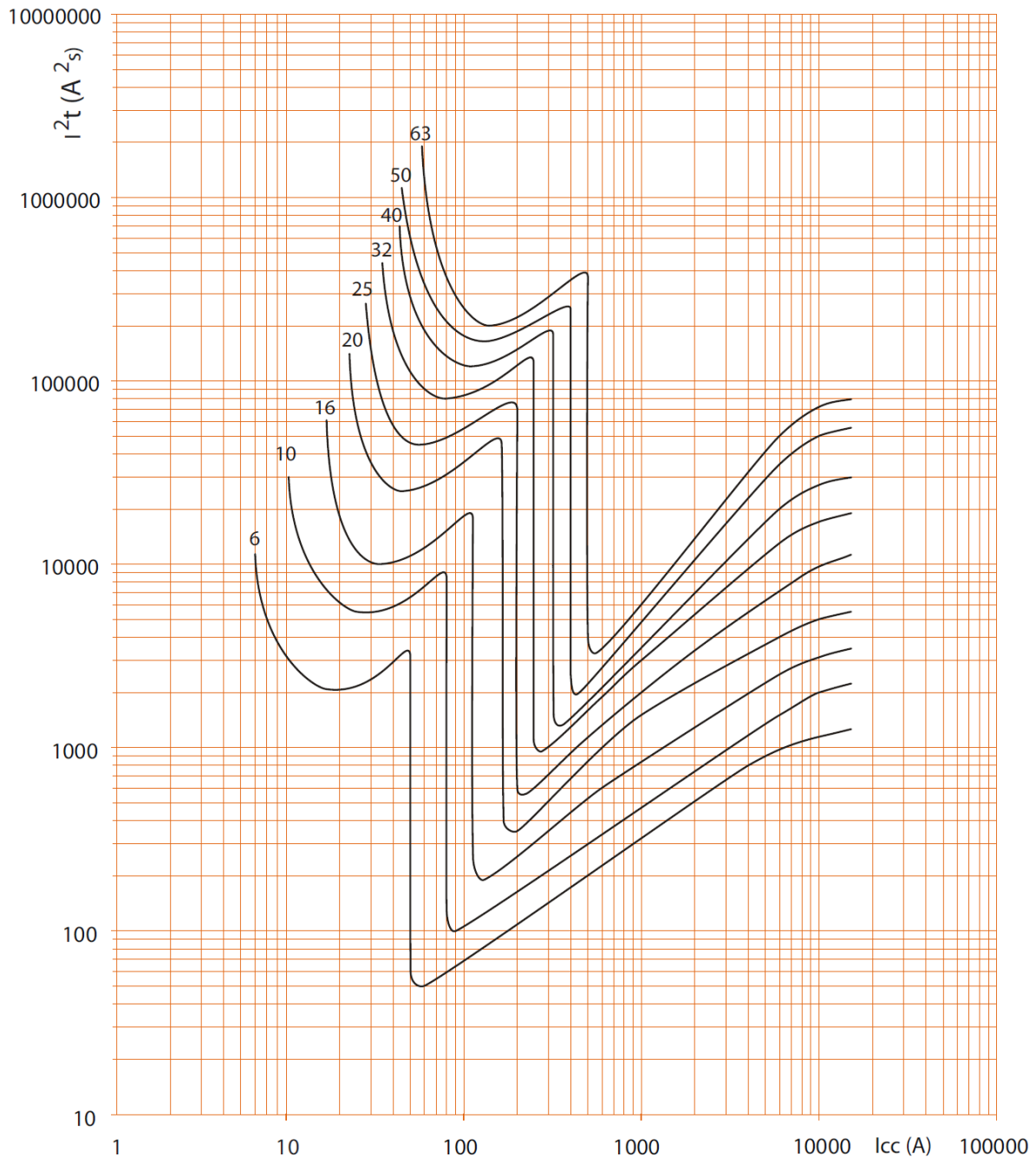

. I_{cc} = Square value of symmetric component of the short circuit current (kA).

. I^2t = Thermal energy limited (A²s).

Circuit breaker DX³ 10000 A / 16 kA up to 63A (1 module per pole)

Cat. N° (s) : 4 088 80 to 4 093 61

8. AUXILIARIES AND ACCESSORIES

Coupling with RCD add-on modules up to 63A:

m.c.b.	r.c.d.		
	2P	3P	4P
2P	X	-	-
3P	-	X	-
4P	-	-	X

Wiring accessories:

- . Fork busbar (on lower side only)
- . Pin busbar HX³ traditional.
- . Sealable screw cover (cat n° 4 063 04).
- . Insulating shields (cat n° 4 063 05)
- . Dispatcher row Lexiclic
- . Dispatcher row HX³.
- . Terminal for aluminium cable (10 mm² to 50 mm²) necessary use (cat n° 4 063 10).

Signalling auxiliaries:

- . Auxiliary contact (½ module – cat n° 4 062 58).
- . Fault signalling changeover switch (½ module – cat n° 4 062 60).
- . Auxiliary contact modifiable in default signal (½ module – cat n° 4 062 62).
- . Auxiliary contact + fault signalling switch - can be modified to 2 auxiliary contacts (1 module - cat n° 4 062 66).

Signalling auxiliaries - prong busbar adapted:

- . Auxiliary contact (½ module – cat n° 4 062 58).
- . Fault signalling changeover switch (½ module – cat n° 4 062 60).
- . Auxiliary contact modifiable in default signal (½ module – cat n° 4 062 62).
- . Auxiliary contact + fault signalling switch - can be modified to 2 auxiliary contacts (1 module - cat n° 4 062 66).

Control auxiliaries:

- . Shunt releases (1 module - cat n° .4 062 76 /78).
- . Under voltage release (1 module - cat n° 4 062 80 /82).
- . Overvoltage release POP (1 module - cat n° 4 062 86)
- . Autonomous shunt trip for NC push-button (1 module - cat n° . 4 062 84 / 87).

Motor driven control modules:

- . Motor driven control 24-48V / 230V (1 module – cat n° 4 062 90 /91)
- . Motor driven control module with automatic resetting integrated (2 modules – cat n° 4 062 93 /95)

Automatic resetting:

- . Automatic resetting STOP & Go (2 modules – cat n° 4 062 88 / 89).
- . Automatic resetting Wi-fi connected STOP & Go (4 modules – cat n° 4 149 54).

8. AUXILIARIES AND ACCESSORIES (continued)

Possible combinations of circuit-breaker and auxiliaries:

- . Only the association of an MCB with signalling auxiliaries guarantees the functionality of the "Great Dispatcher" DIN rail clamp.
- . Auxiliaries are clipped on the left of the circuit-breaker
- . Maximum number of auxiliaries for one circuit-breaker: 3.
- . Two signalling auxiliaries max. (cat. n° 4 062 50 /52 /56 /64).
- . Only one control auxiliary (cat. n° 4 062 76 / 78 / 80 / 82 / 84 / 86 /87).
- . One remote motor driven remote control or one STOP & GO automatic resetting.
- . If signalling and control auxiliaries are associated on the same circuit-breaker, the con auxiliary must be placed to the left of the signal auxiliary

Front external rotary handle

- . Black handle (cat n° 4 063 19)
- . Yellow and red handle (cat n° 4 063 20)

Supply Invertor

- . Manual supply invertor for 2P devices (cat. n° 4 063 14)

Sealing:

- . Possible in "Open" position (OFF) or "Close" position (ON).

Locking:

- . By 5 mm padlock (cat. N° 4 063 13) or 6 mm padlock (cat. N° 0 227 97) with padlock support (cat. N° 0 044 42) in "Open" position (OFF).

Installation software:

- . XL PRO³

9. USE IN DIRECT CURRENT

- . Refer to F03693EN