

INSTALLATION GUIDE

CABLE TRAY SYSTEM P31

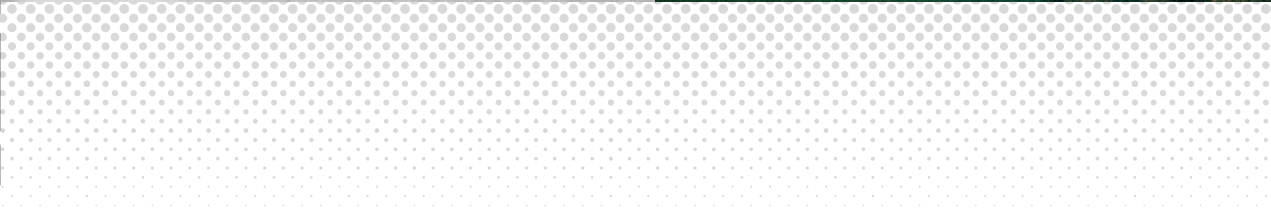

Legrand presents P31+, an even wider and more innovative range of cable trays. We have developed solutions adapted to all situations to make the installation even easier.

The new automatic junction and the male/female interlocking system guarantee you a fast, simple, and safe mounting in all situations.

As well as a possible disassembly of the cable tray.

In addition, with a new embossing shapes on the bottom and innovative accessories, complete and easy to assemble, the P31+ offer is confirmed to be one of the most complete on the market.

LEGAL INFORMATION

Presentation pictures do not always include Personal Protective Equipment (PPE), but this is a legal and regulatory obligation that must be scrupulously respected.

In accordance with its continuous improvement policy, Legrand reserves the right to change the specifications and illustrations without notice. All illustrations, descriptions and technical information included in this document are provided as indications and cannot be held against Legrand.

It offers real freedom of movement by allowing the realization of multiple configurations in a wide choice of finishes for optimal integration in all environments.

TABLE OF CONTENTS

1- SAFETY INSTRUCTIONS.....	4
2- UTILITIES.....	7
3- TECHNICAL CHARACTERISTICS.....	8
4- LENGTH ASSEMBLING.....	10
A- Perforated cable tray.....	10
B- Blind cable tray.....	20
5- DISASSEMBLY AUTOMATIC COUPLER.....	31
6- LENGTH ASSEMBLY AFTER CUTTING.....	32
A- Perforated cable trays.....	33
B- Blind cable trays.....	41
C- Rubber protection.....	41
7- P31 COVER LENGTH.....	42
A- Horizontal application.....	42
B- Vertical application.....	42
C- Clip cover.....	44
D- Electrical continuity for covers.....	45
8- INSTALLING A FITTING.....	46
A- Slide-in system.....	46
B- Flat bend 90°.....	48
C- Flat bend 45°.....	51
D- Adjustable flat bend.....	54
E- Equal tee.....	56
F- 4Way.....	58
G- T-Branch.....	61
H- Universal branch.....	65
I- Inside riser.....	66
J- Outside riser.....	68
K- Outside riser twist.....	69
L- Vertical tee.....	70
M- Vertical branch piece.....	70

TABLE OF CONTENTS

9- FITTING TO FITTING ASSEMBLY	71
A- H50-60.....	71
B- H75-100.....	71
C- Electrical continuity for painted version.....	71
10- ADJUSTABLE BEND FITTING	72
A- H60 flexible bend (15° - 30° - 45°).....	73
B- H100 flexible bend (15°).....	74
C- H60 inside-outside riser.....	74
D- H100 inside-outside riser.....	75
11- VERTICAL COUPLER	76
12- EDU COUPLER	78
A- EDU - Flat bend (15° - 30° - 45°).....	78
B- EDU - Flat bend (90°).....	80
C- EDU - End-cap.....	80
D- EDU - Reducer.....	81
E- EDU - Inside - Outside riser bend.....	81
F- EDU - Outside riser 90°.....	83
G- EDU - T-Branch with angle.....	85
H- EDU - T-Branch.....	87
I- EDU for cover.....	87
13- REDUCER	88
A- H50-60.....	88
B- H100.....	88

TABLE OF CONTENTS

14- DIVIDERS	90
A- Universal divider for length.....	90
B- Automatic divider for length.....	91
C- Universal dividers for fittings.....	92
D- End-cap divider's protection.....	93
15- END-CAP	97
16- FLANGE CABINET	99
A- H50 from width 50 to 300mm.....	99
B- H50 from width 400 to 600mm.....	99
17- ELECTRICAL CONTINUITY OF CONNECTION (UL CERTIFICATION)	100
A- Example of sizing.....	101
B- Cross sectional area of cable trays (tables).....	105
18- H60 - FIRE RESISTANT CONFIGURATION E30, E60, E90	112
A- Cable tray assembling.....	112
B- CRP configuration.....	113
C- CB bracket and threaded rod configuration.....	113
D- R21S trapeze configuration.....	114
E- U55 pendant and CB bracket configuration.....	115
F- U55 pendant and CB bracket multiple configuration.....	116

SAFETY

INSTRUCTIONS

General information

- Use only the products and accessories recommended by the Legrand Group in the catalogue, instructions, technical data sheets and all other documents provided by Legrand (hereinafter referred to as «the Documentation») in compliance with the installation rules.
- Improper installation and/or use may result in the risk of arcing in the enclosure, overheating or fire. The enclosures must be used under normal conditions, they must not be subjected to Voltage / Current / Temperature values other than those specified in the Documentation.
- Legrand declines all responsibility for any modification or repair of the equipment making up the enclosure that is not authorized by the Legrand Group, as well as any failure to comply with the rules and recommendations specified by Legrand in the Documentation. In addition, in the cases mentioned above, the warranty granted by Legrand will not be applicable.
- It is necessary to check that the characteristics of the products are appropriate for their environment and use during maintenance operations, and to refer to the Documentation. If you have any questions or require clarification, please contact Legrand Group.
- The installation, use and maintenance of the enclosures and their components must be carried out by qualified, trained and authorized personnel, in accordance with the regulations in force in each country.



RISK OF ELECTRIC SHOCK, BURNS AND EXPLOSION.

- People working on the installation must have the appropriate electrical authorizations for the work to be carried out.
- Wear the PPE (Personal Protective Equipment) necessary to work on live products.
- Respect the safety rules related to electrical work.
- Improper electrical and mechanical use of equipment can be dangerous and may result in personal injury or damage to property.
- Depending on the maintenance operations to be carried out, partial or total power cuts of the enclosure concerned should be planned before any work.
- When performing operations that involve access to the inside of the enclosure, be aware of the risk of burns before touching any products or metal parts.
- Before turning the power back on, make sure that there are no foreign bodies and that all physical protections have been put back in place (e.g.: screens, covers, shields).

Any failure to strictly apply the procedures and to respect these recommendations, could lead to serious risk of accident, endangering people and property (in particular, without limitation, risk of burns, electric shocks, etc.).



 The rules and recommendations in this document are based on our knowledge of the typical conditions of use of our products in the fields of application usually encountered. However, it is always the customer's responsibility to verify and validate that Legrand products are suitable for its installation and use.

The customer must ensure proper installation, maintenance and operation of the equipment to avoid any risk of injury to personnel or damage to property in the event of product failure, especially for applications that require a very high level of safety (e.g., those in which the failure of a component may endanger human life or health).

The rules for storage, handling, installation and maintenance and the appropriate precautions and warnings must be strictly observed and applied.

GENERAL

- Please use suitable gloves throughout the installation of our products in order to protect your hands from potentially sharp metal parts.
- Please wear suitable safety glasses when cutting or grinding metal products.
- Please use protective devices where necessary and as required on your site.
- When working on heights, please take protective safety measures.
- Please pay attention to the safety working loads (SWL) of our system before the installation in order to prevent misapplication. SWL are available in our technical sheets and don't hesitate to contact your local LEGRAND sales office if you have any questions related to them or any other topic.

Avoid dangerous situations for you and the people around you at all times!

2- UTILITIES

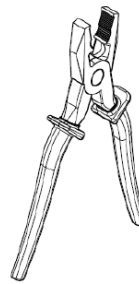
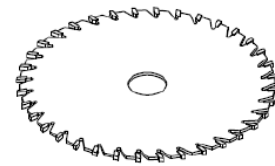
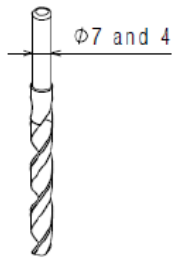
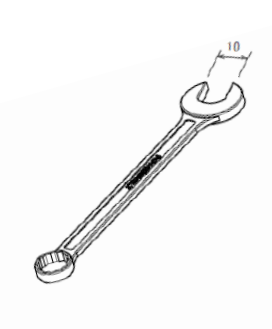

3- TECHNICAL CHARACTERISTICS

Straightening					
	25 M/F	50 M/F	75 M/F	75 AUTO	100 M/F
50	n°2 - 03V1M610... on the bottom	n°2 - 03V1M610... on the sides	-	-	-
75	n°2 - 03V1M610... on the bottom	-	n°4 - 03V1M610... on the sides	Click	-
100	n°2 - 03V1M610... on the bottom	n°2 - 03V1M610... on the sides	n°4 - 03V1M610... on the sides	Click	n°4 - 03V1M610... on the sides + n°1 - 03V1M610 on the bottom
150	n°2 - 03V1M610... on the bottom	n°2 - 03V1M610... on the sides	n°4 - 03V1M610... on the sides	Click	n°4 - 03V1M610... on the sides + n°1 - 03V1M610 on the bottom
200	n°2 - 03V1M610... on the bottom	n°2 - 03V1M610... on the sides	n°4 - 03V1M610... on the sides	Click	n°4 - 03V1M610... on the sides + n°1 - 03V1M610 on the bottom
300	n°2 - 03V1M610... on the bottom	n°2 - 03V1M610... on the sides	n°4 - 03V1M610... on the sides	Click	n°4 - 03V1M610... on the sides + n°1 - 03V1M610 on the bottom
400	n°3 - 03V1M610... on the bottom	n°2 - 03V1M610... on the sides + n°1 - 03V1M610 on the bottom	n°4 - 03V1M610... on the sides + n°1 - 03V1M610 on the bottom	Click + n°1 - 03V1M610... on the bottom	n°4 - 03V1M610... on the sides + Piastra di allineamento basi
500	n°3 - 03V1M610... on the bottom	n°2 - 03V1M610... on the sides + n°1 - 03V1M610 on the bottom	n°4 - 03V1M610... on the sides + n°1 - 03V1M610 on the bottom	Click + n°1 - 03V1M610... on the bottom	n°4 - 03V1M610... on the sides + Piaque d'alignement du socle
600	-	n°2 - 03V1M610... on the sides + Piastra di allineamento basi	n°4 - 03V1M610... on the sides + n°1 - 03V1M610 on the bottom	Click + n°1 - 03V1M610... on the bottom	n°4 - 03V1M610... on the sides + Plaque d'alignement du socle

Straightening / Accessories

	25 M/F	50 M/F	75 M/F - AUTO	100 M/F
50	n°2 - 03V1M610... on the bottom	n°2 - 03V1M610... on the sides	-	-
75	n°2 - 03V1M610... on the bottom	-	n°4 - 03V1M610... on the sides	-
100	n°2 - 03V1M610... on the bottom	n°2 - 03V1M610... on the sides	n°4 - 03V1M610... on the sides	n°4 - 03V1M610... on the sides
150	n°2 - 03V1M610... on the bottom	n°2 - 03V1M610... on the sides	n°4 - 03V1M610... on the sides	n°4 - 03V1M610... on the sides
200	n°2 - 03V1M610... on the bottom	n°2 - 03V1M610... on the sides	n°4 - 03V1M610... on the sides	n°4 - 03V1M610... on the sides
300	n°2 - 03V1M610... on the bottom	n°2 - 03V1M610... on the sides n°1 - 03V1M610... on the bottom	n°4 - 03V1M610... on the sides n°1 - 03V1M610... on the bottom	n°4 - 03V1M610... on the sides n°1 - 03V1M610... on the bottom
400	n°3 - 03V1M610... on the bottom	n°2 - 03V1M610... on the sides n°1 - 03V1M610... on the bottom	n°4 - 03V1M610... on the sides n°1 - 03V1M610... on the bottom	n°4 - 03V1M610... on the sides n°1 - 03V1M610... on the bottom
500	n°3 - 03V1M610... on the bottom	n°2 - 03V1M610... on the sides n°1 - 03V1M610... on the bottom	n°4 - 03V1M610... on the sides n°1 - 03V1M610... on the bottom	n°4 - 03V1M610... on the sides n°1 - 03V1M610... on the bottom
600	-	n°2 - 03V1M610... on the sides n°1 - 03V1M610... on the bottom	n°4 - 03V1M610... on the sides n°1 - 03V1M610... on the bottom	n°4 - 03V1M610... on the sides n°1 - 03V1M610... on the bottom

4- LENGTH ASSEMBLING

A- PERFORATED CABLE TRAY

- **H50 with male - female automatic coupler system:**

The automatic junction system does not need any screws up to and including width 300mm.

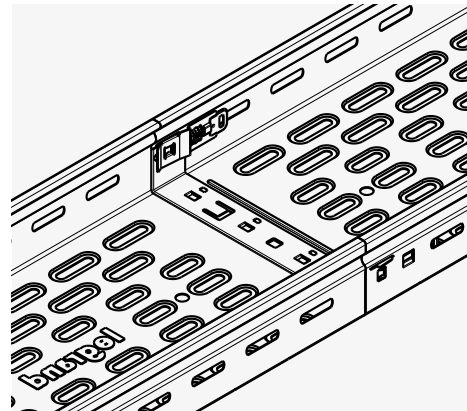
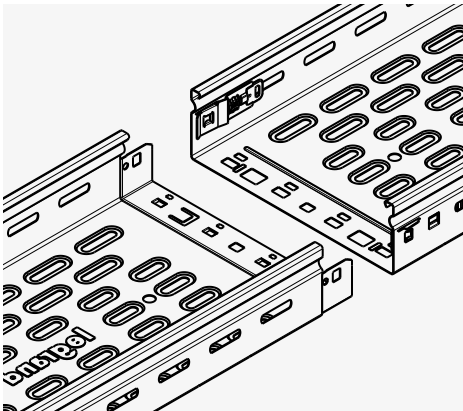

Put an extra screw M6x12 in the middle from width 400 to 500mm. For painted version put the third screw in the middle for all widths to assure electric conductivity.

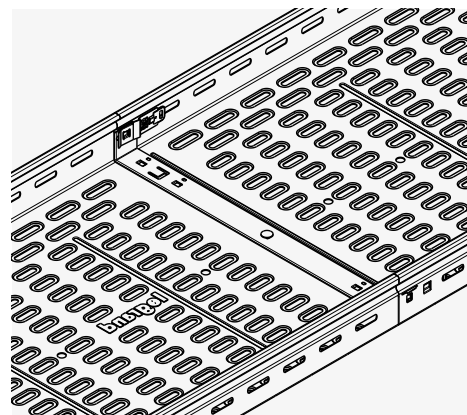
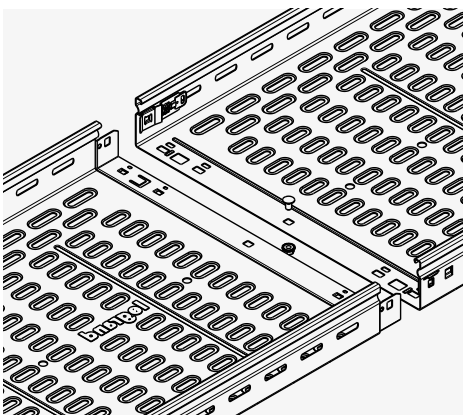

- **H50 with male - female automatic coupler system (continued)**

Put an extra bottom plate on width 600mm using 5 additional screws M6x12.

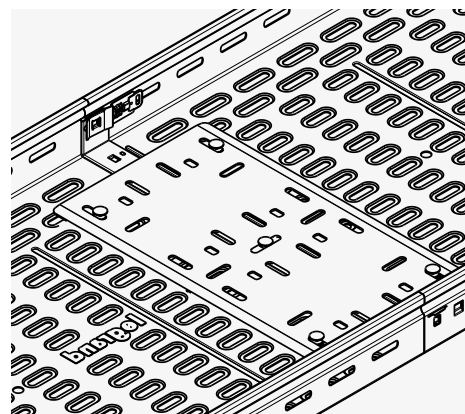
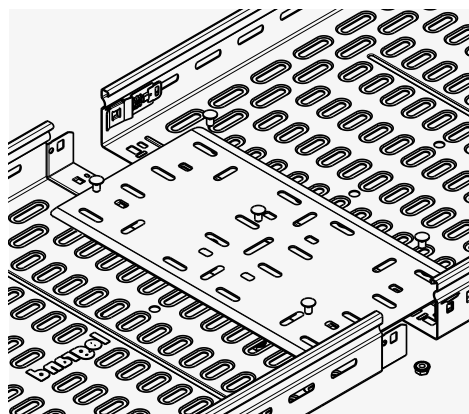

- **H60 with male - female automatic coupler system:**

The automatic junction system does not need any screws up to and including width 300mm.

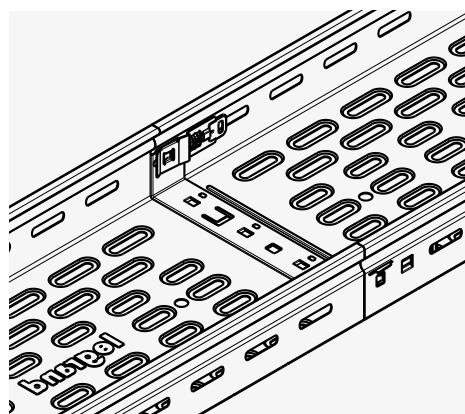
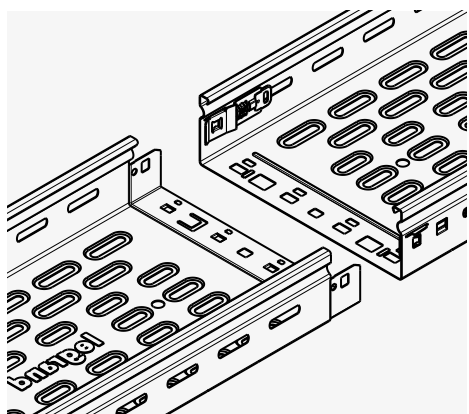

- **H60 with male - female automatic coupler system (continued):**

Put an extra bottom plate on width from 400 to 600mm using 5 additional screws M6x12. For painted version put the third screw in the middle for all widths to assure electric conductivity.

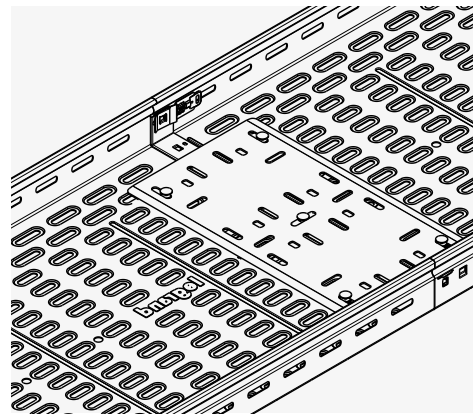
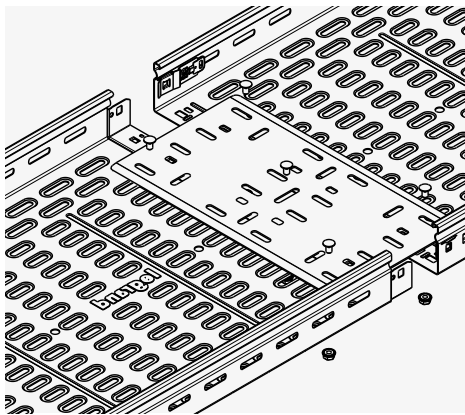

- **Male - female system:**

- **H25**

Height 25mm is assembled using 3 screws M6x12 on the bottom. The third screw in the middle is an optional up to and including width 300mm. For painted version put the third screw in the middle for all widths to assure electric conductivity.

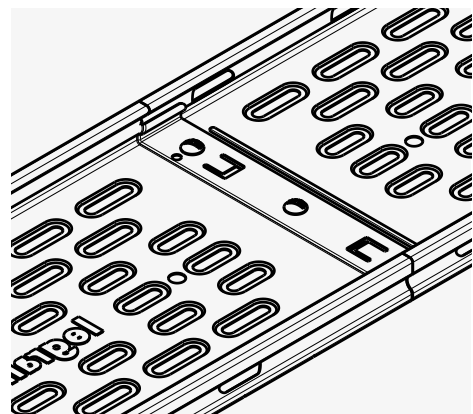
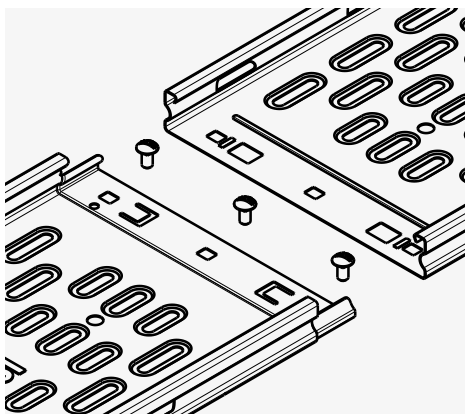

▪ **H50**

Height 50mm is assembled using 3 screws M6x12 on the bottom. The third screw in the middle is an optional on width until 300mm included. For painted version put the third screw in the middle for all widths to assure electric conductivity.

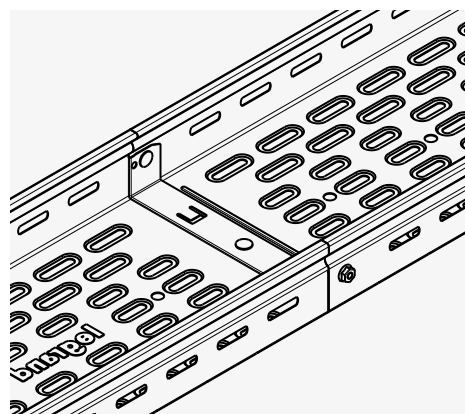
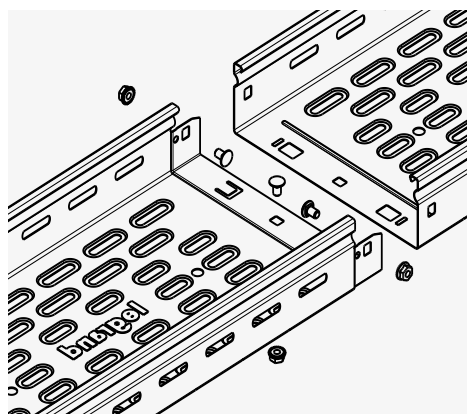

Put an extra screw M6x12 in the middle from width 400 to 500mm.

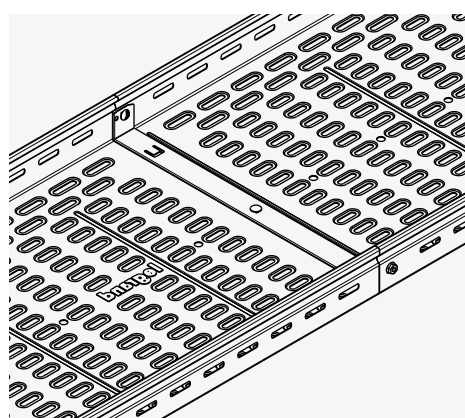
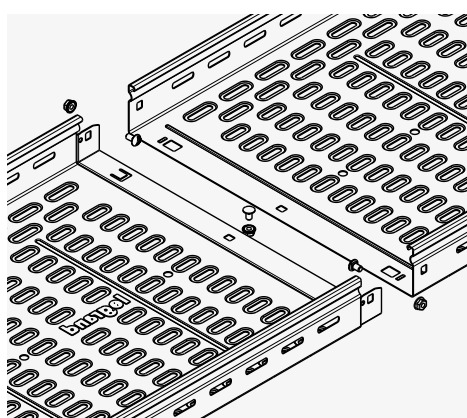

- **H50 (continued)**

Put an extra bottom plate on width 600mm using 5 additional screws M6x12.

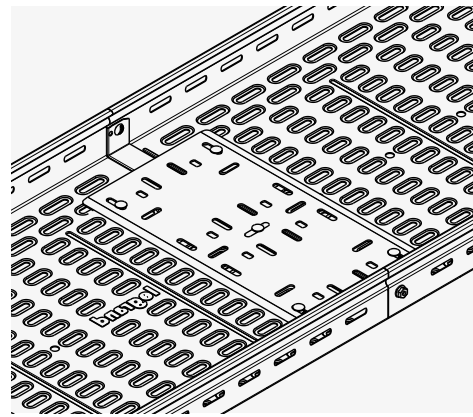
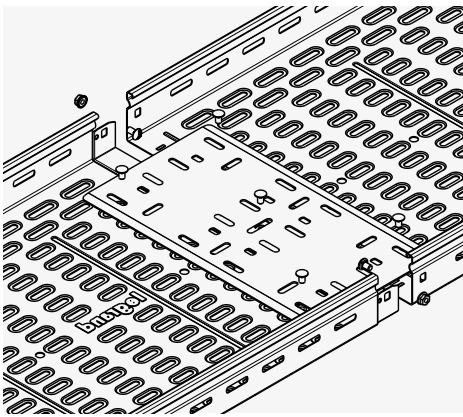

- **H60**

Height 50 and 60mm are assembled using 3 screws M6x12 on the bottom. The third screw in the middle is an optional on width until 300mm included. For painted version put the third screw in the middle for all widths to assure electric conductivity.

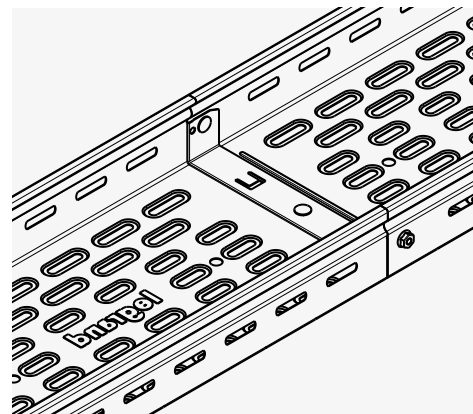
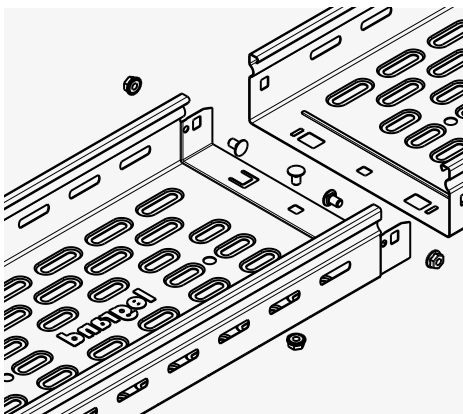

- **H60 (continued)**

Put an extra bottom plate on width from 400 to 600mm using 5 additional screws M6x12.

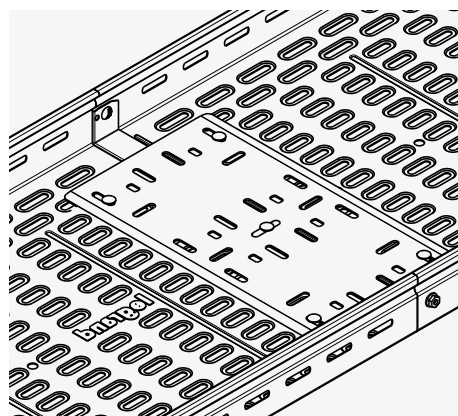
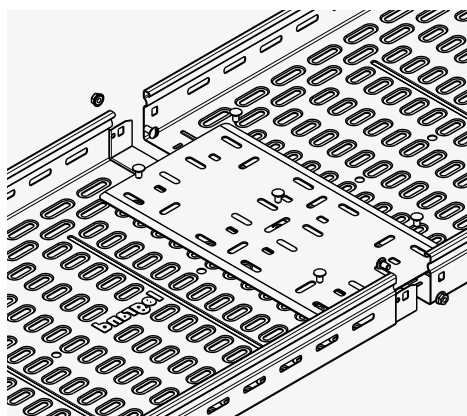

- **H100**

Height 100mm is assembled using 5 screws M6x12 on the bottom. For painted version put the third screw in the middle for all widths to assure electric conductivity.

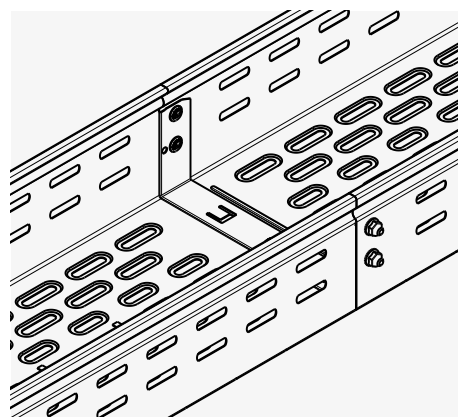
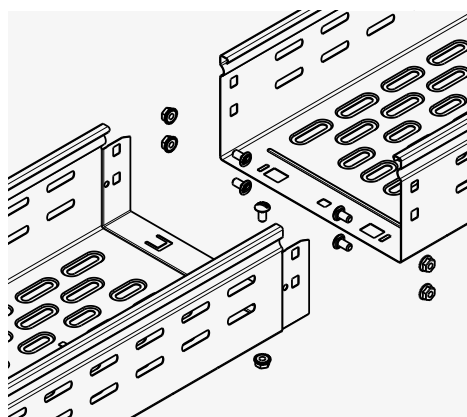

- **H100 (continued)**

Put an extra bottom plate on width from 400 to 600mm using 5 additional screws M6x12.

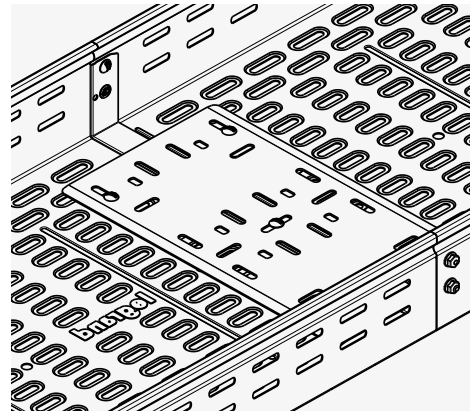
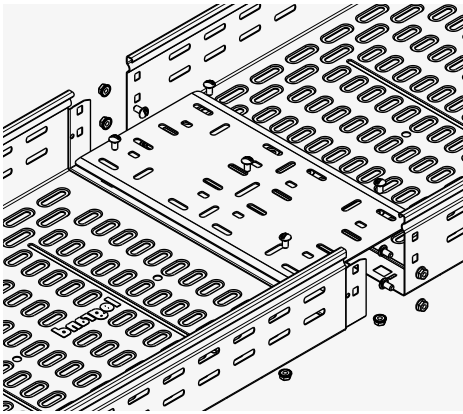

- **H60 symmetrical cable tray:**

P31 symmetrical cable trays are available in height 60mm and are assembled using two ECLIC couplers.

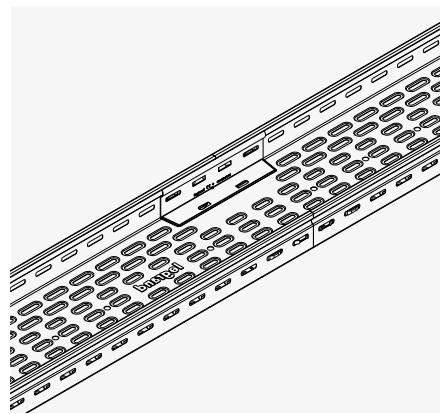
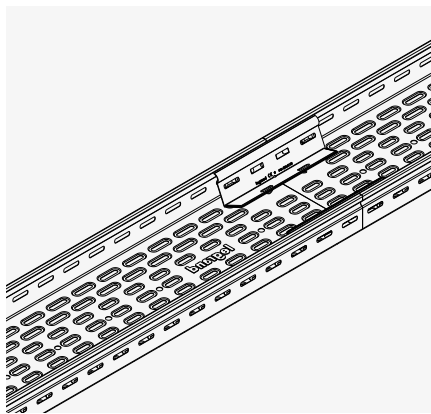
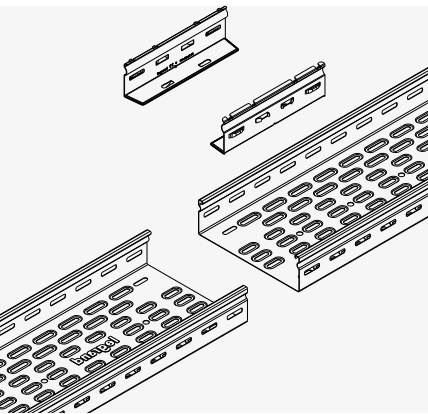

▪ **H60 symmetrical cable tray (continued):**

Put an extra bottom plate on width from 400 to 600mm with other 4 screws M6x12.

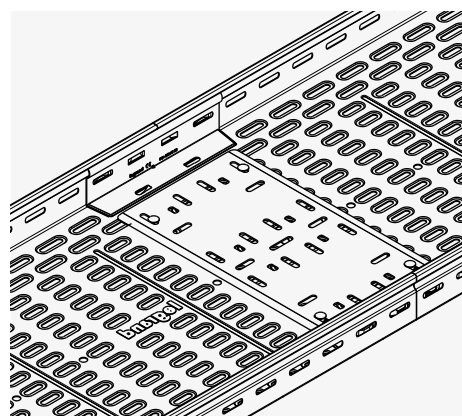
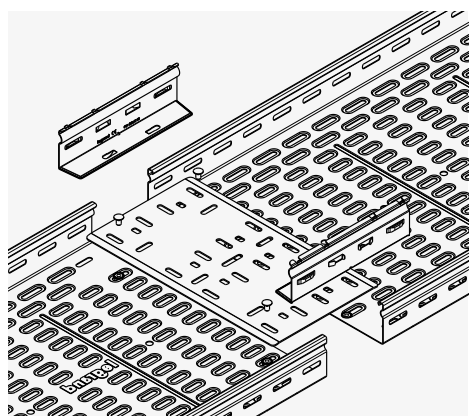

For painted version use EP coupler and 4 screws M6x12 on each coupler to assure electric conductivity.

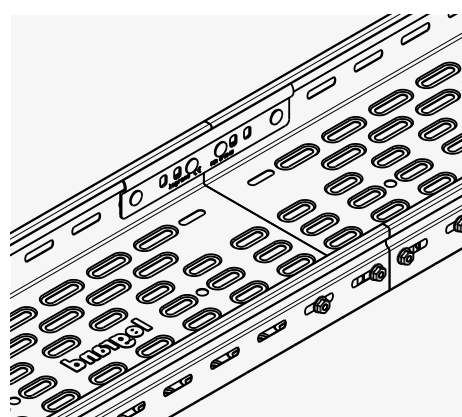
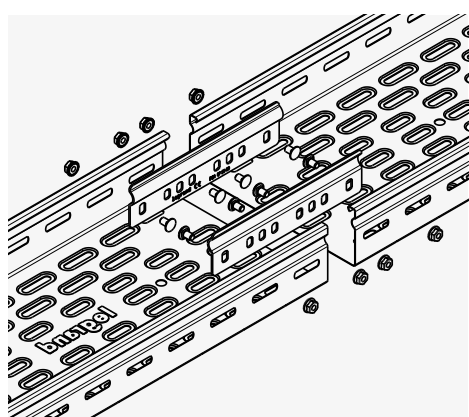

- **H60 symmetrical cable tray (continued):**

Put an extra bottom plate on width from 400 to 600mm using 5 additional screws M6x12.

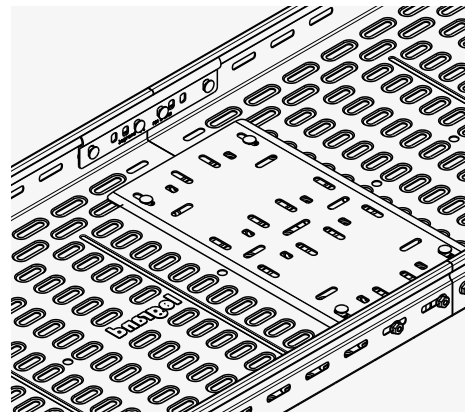
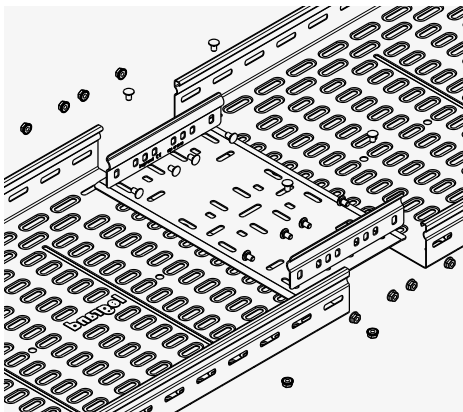

- **Heavy duty cable tray:**

P31 heavy duty model are symmetrical cable tray type with increased material thickness.

- **H25**

Height 25mm is assembled using two external couplers and 4 screws M6x12 on each coupler.

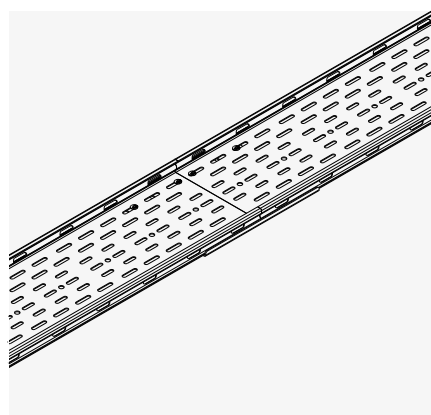
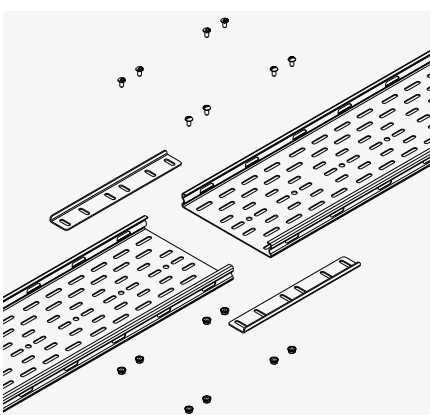

▪ **H50-H60**

Height 50 and 60mm Heavy Duty up to and included width 300mm is assembled using two external couplers and 4 screws M6x12 on each coupler.

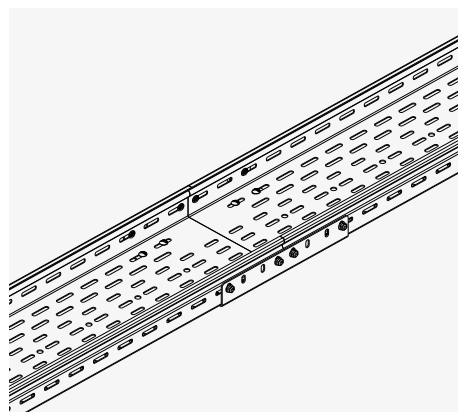
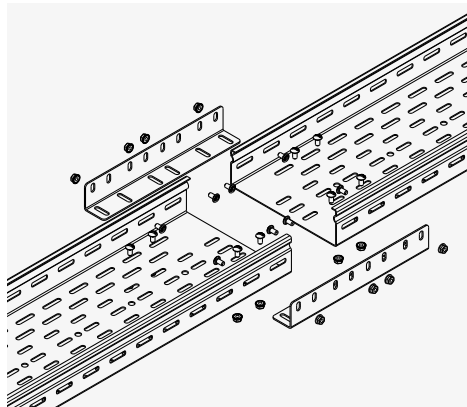

Put an extra bottom plate on width from 400 to 600mm with other 4 screws M6x12.

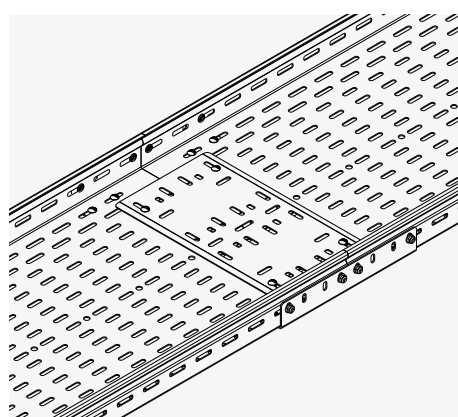
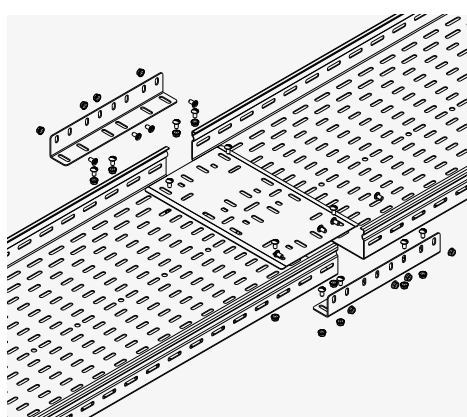

- **H100**

Height 100mm Heavy Duty up to and included width 300mm is assembled using two external couplers and 8 screws M6x12 on each coupler. Put an extra bottom plate on width from 400 to 600mm with other 4 screws M6x12.

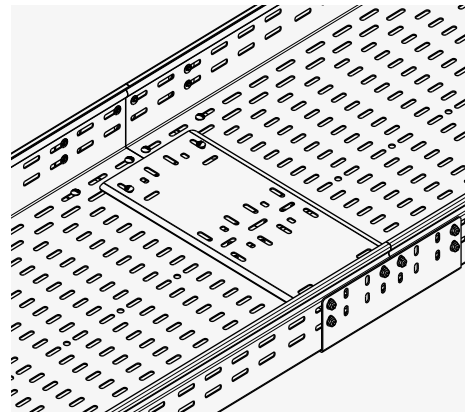
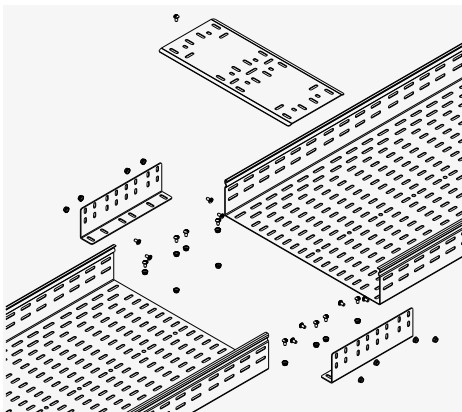

B- BLIND CABLE TRAY

- **H50 with male - female automatic coupler system:**

The automatic junction system does not need any screws up to and including width 300mm.

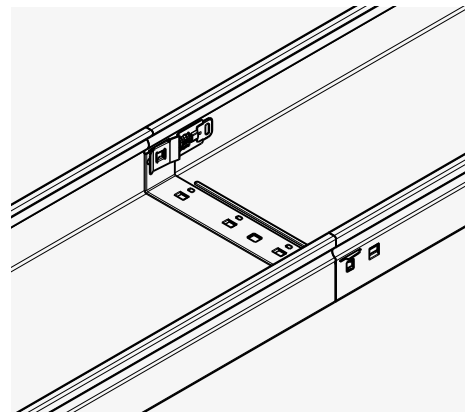
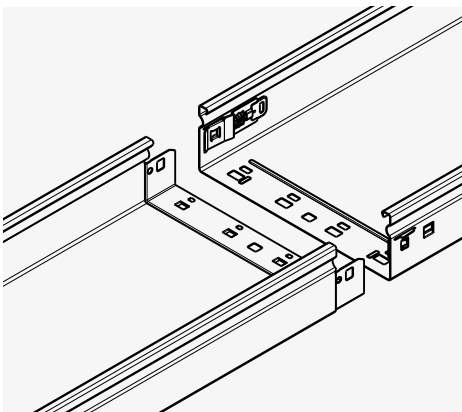

▪ **H50 with male - female automatic coupler system (continued):**

Put an extra screw M6x12 in the middle from width 400 to 500mm. For painted version put the third screw in the middle for all widths to assure electric conductivity.

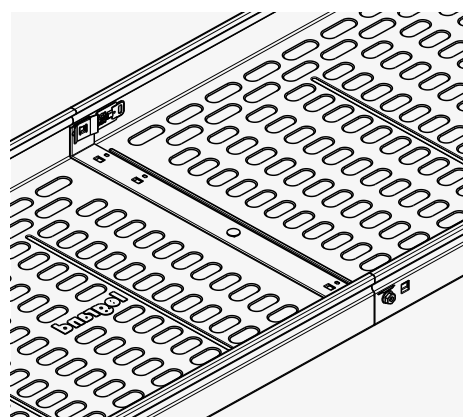
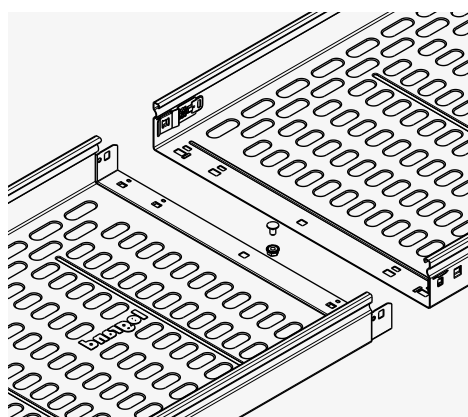

Put an extra bottom plate on width 600mm using 5 additional screws M6x12. Drill 4 holes in the bottom to fix the bottom plate; use 7mm diameter drill bit.

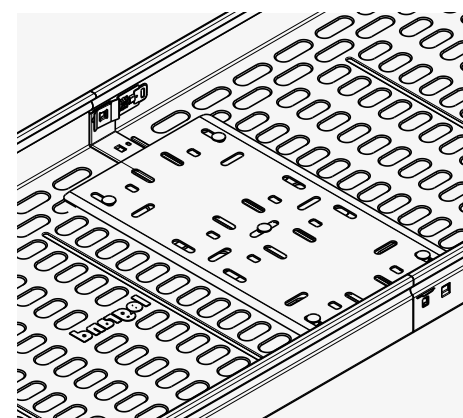
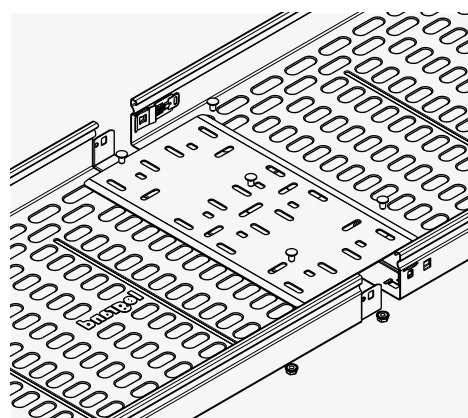

- **H60 with male - female automatic coupler system**

The automatic junction system does not need any screws up to and including width 300mm.

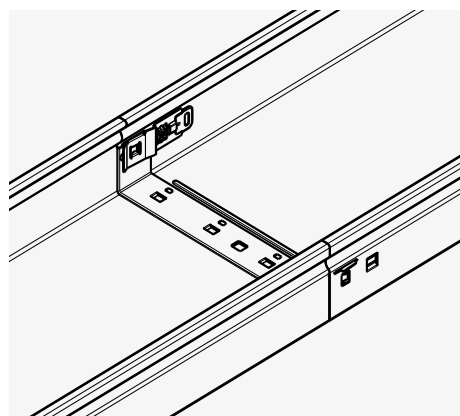
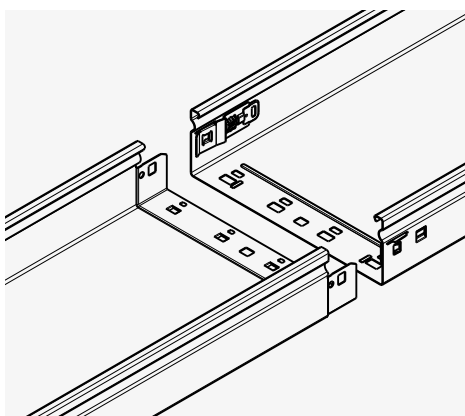

Put an extra bottom plate on width from 400 to 600mm using 5 additional screws M6x12. For painted version put the third screw in the middle for all widths to assure electric conductivity. Drill 4 holes in the bottom to fix the bottom plate; use 7mm diameter drill bit.

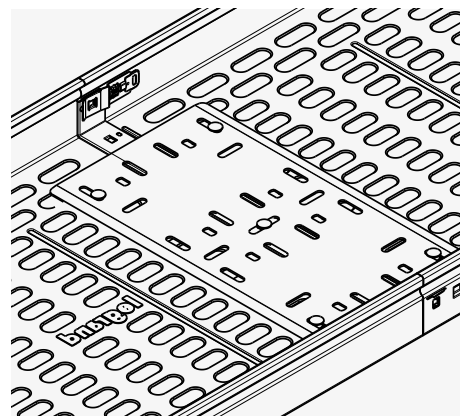
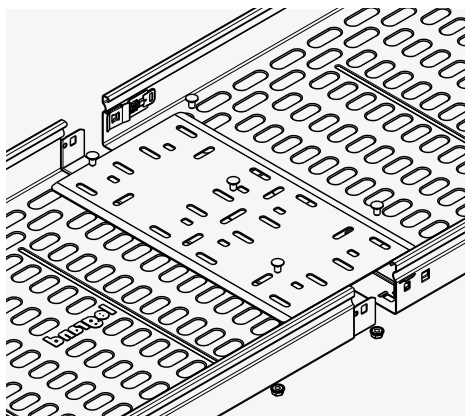

- **Male - female system:**

- **H50**

Height 50mm is assembled using 3 screws M6x12 on the bottom. The third screw in the middle is an optional on width until 300mm included.

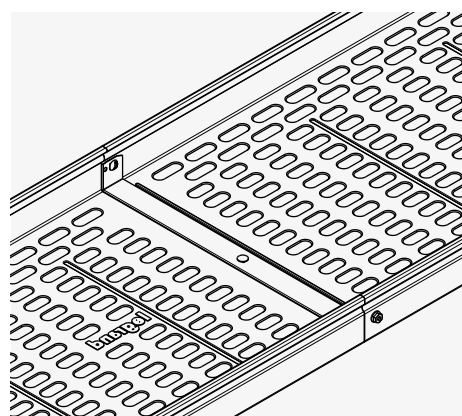
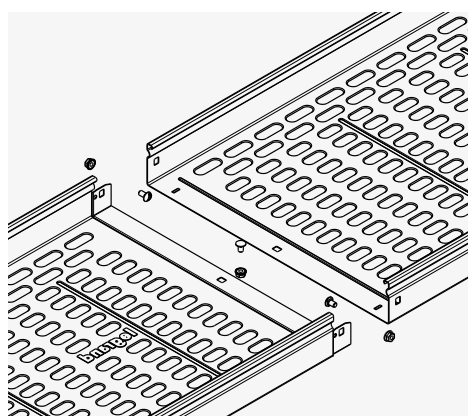

Put an extra screw M6x12 in the middle from width 400 to 500mm. For painted version put the third screw in the middle for all widths to assure electric conductivity.

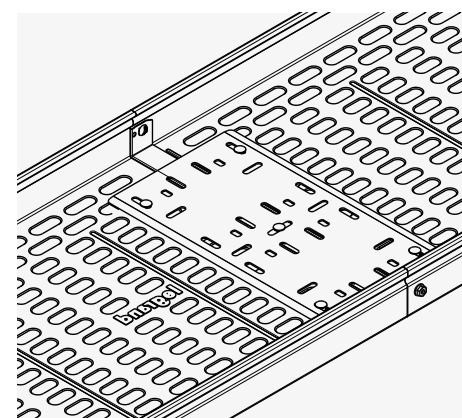
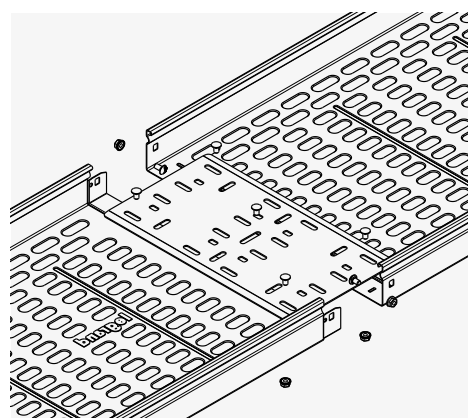

- **H50 (continued)**

Put an extra bottom plate on width 600mm using 5 additional screws M6x12. Drill 4 holes in the bottom to fix the bottom plate; use 7mm diameter drill bit.

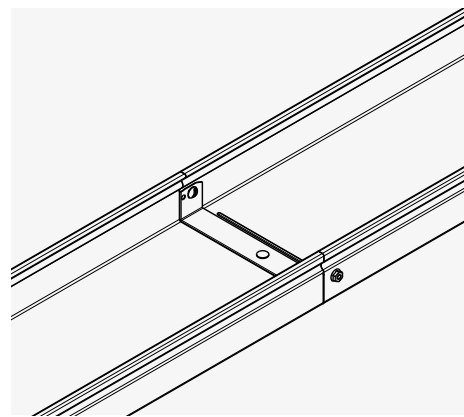
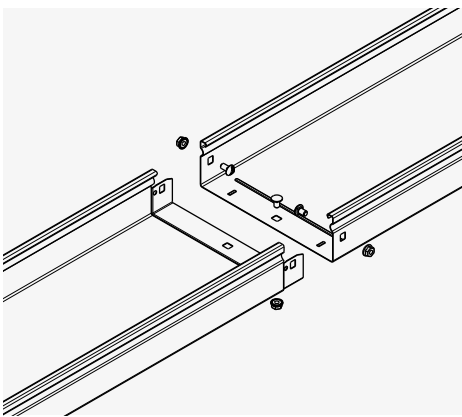

- **H60**

Height 60mm is assembled using 3 screws M6x12 on the bottom. The third screw in the middle is an optional on width until 300mm included. For painted version put the third screw in the middle for all widths to assure electric conductivity.

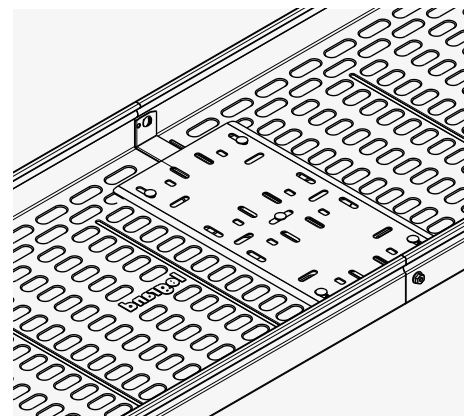
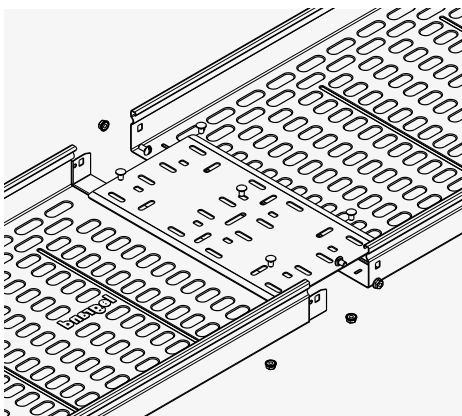

- **H60 (continued)**

Put an extra bottom plate on width from 400 to 600mm using 5 additional screws M6x12. Drill 4 holes in the bottom to fix the bottom plate; use 7mm diameter drill bit.

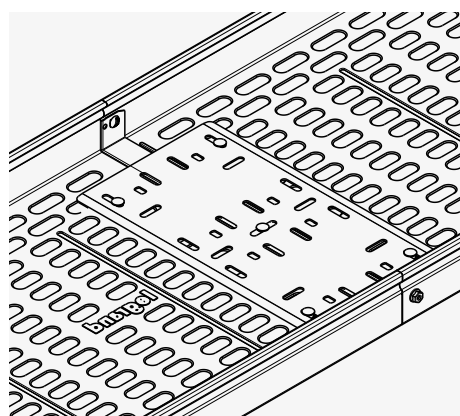
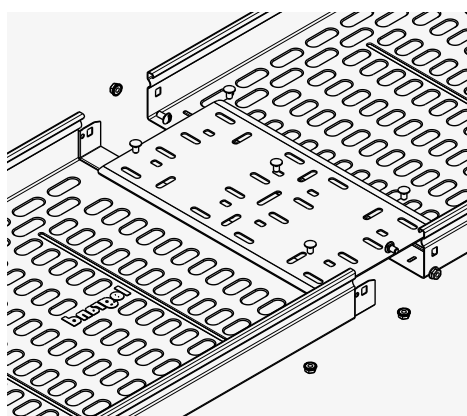

- **H100**

Height 100mm is assembled using 5 screws M6x12 on the bottom. For painted version put the third screw in the middle for all widths to assure electric conductivity.

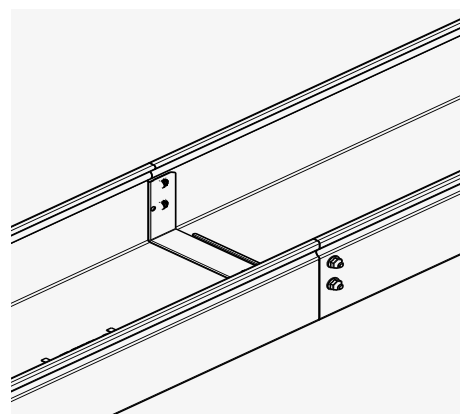
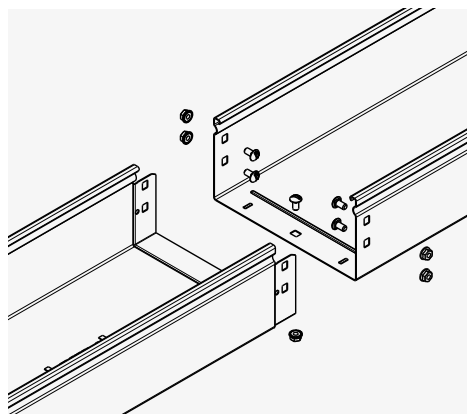

▪ H100 (continued)

Put an extra bottom plate on width from 400 to 600mm using 5 additional screws M6x12. Drill 4 holes in the bottom to fix the bottom plate; use 7mm diameter drill bit.

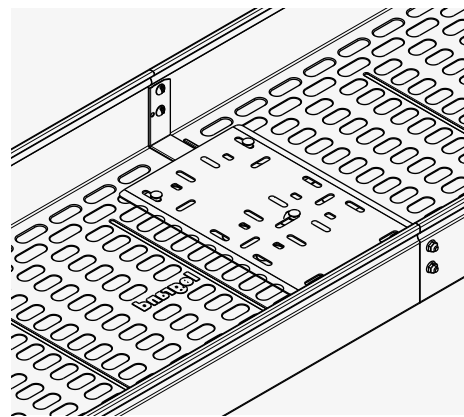
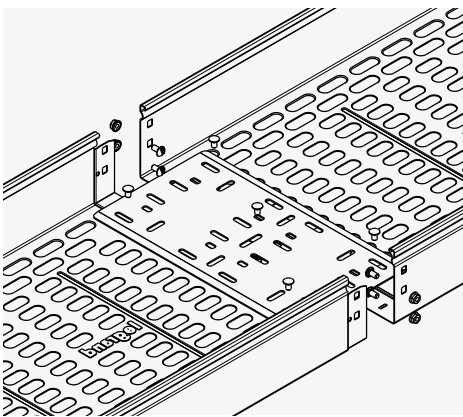

▪ H60 Symmetrical cable tray

P31 symmetrical blind cable trays are available in height 60mm and are assembled using two EP couplers and 4 screws M6x12 on each coupler. For painted version use EP coupler to assure electric conductivity.

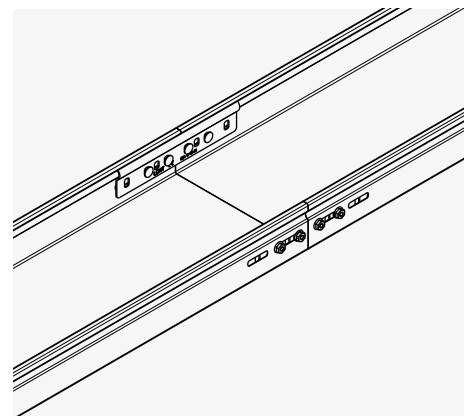
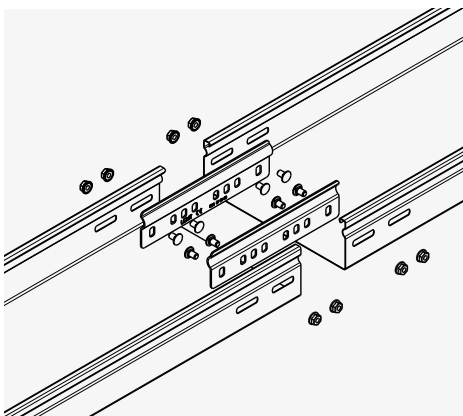

▪ H60 Symmetrical cable tray (continued)

Alternative: use two ER couplers.

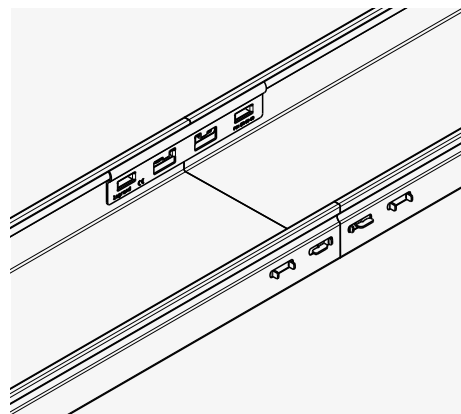
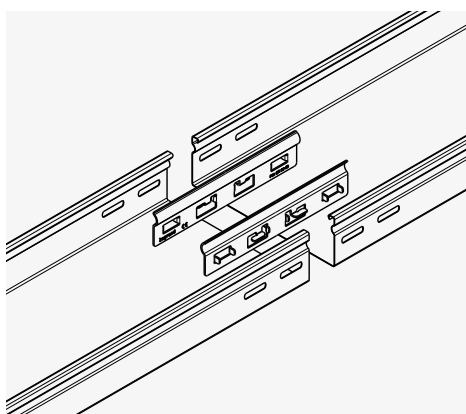

The ER coupler is assembled bending the external wings of the coupler using a pliers.

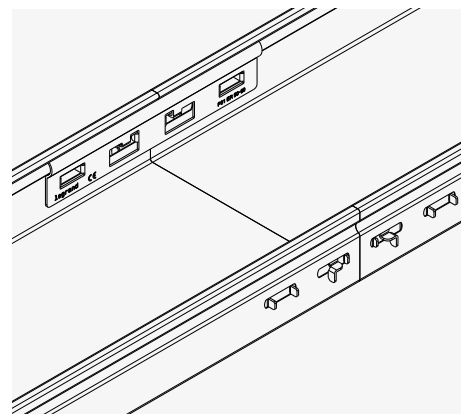
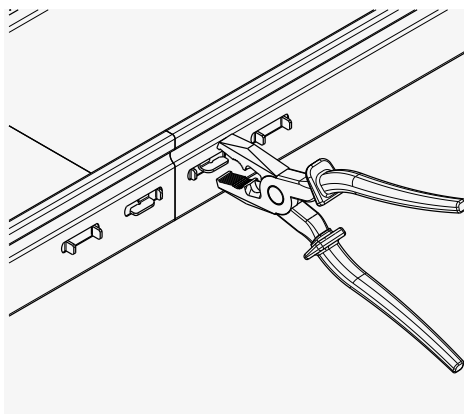

▪ H60 Symmetrical cable tray (continued)

Put an extra bottom plate on width from 400 to 600mm using 4 additional screws M6x12. Drill 4 holes in the bottom to fix the bottom plate; use 7mm diameter drill bit. The bottom plate is compatible with EP and ER coupler.

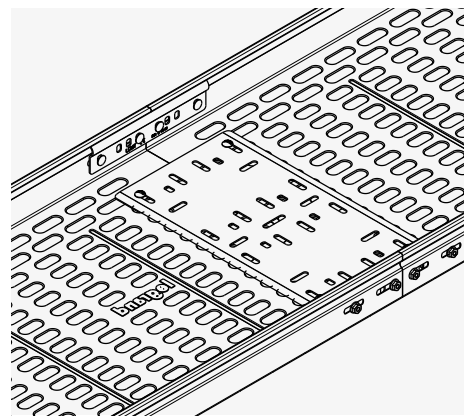
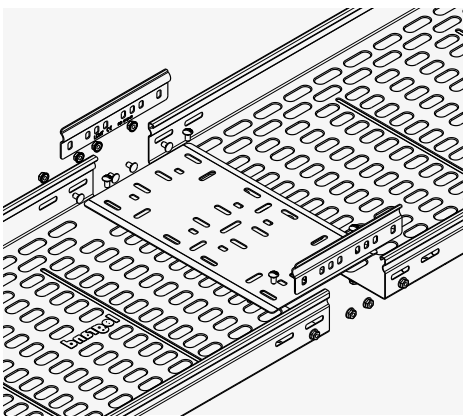

i In case of assembly between painted cable tray and fitting, drill a 7mm holes on the bottom of the tray; quote are showed in the pictures below. Drill the bottom of cable tray in the middle of its width ($W/2$) and to 15mm from the other side. It is important to remove paint from the area near the hole, on both sides, to assure electric conductivity.

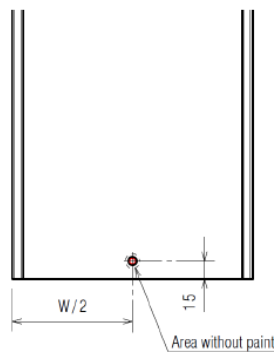
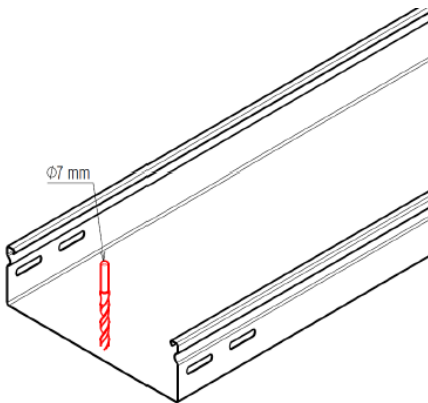

▪ **Heavy Duty cable tray (symmetrical cable tray type with increased material thickness):**

▪ **H60**

Height 60mm Heavy Duty up to and included width 300mm is assembled using two external couplers and 4 screws M6x12 on each coupler.

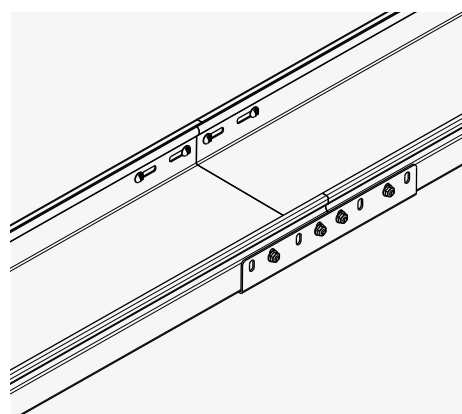
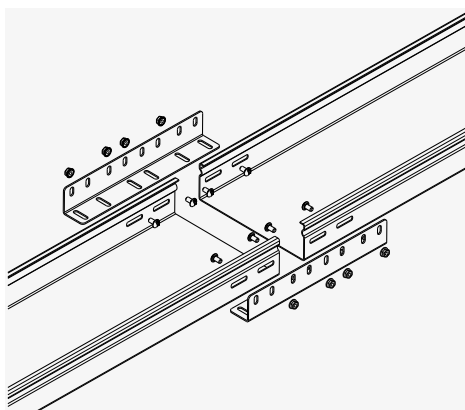

Put an extra bottom plate on width from 400 to 600mm using 4 additional screws M6x12. Drill 4 holes in the bottom to fix the bottom plate; use 7mm diameter drill bit.

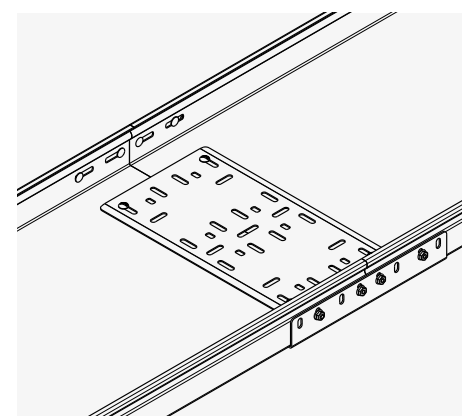
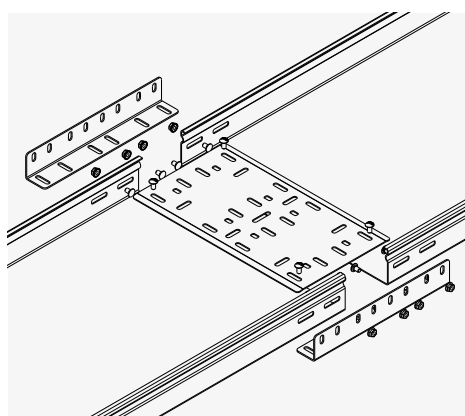

▪ **H100**

Height 100mm Heavy Duty up to and included width 300mm is assembled using two external couplers and 8 screws M6x12 on each coupler.

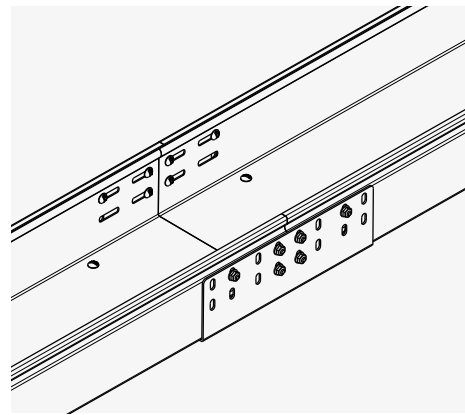
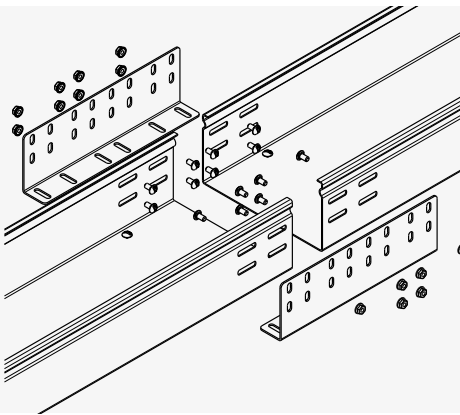

Put an extra bottom plate on width from 400 to 600mm using 4 additional screws M6x12. Drill 4 holes in the bottom to fix the bottom plate; use 7mm diameter drill bit.

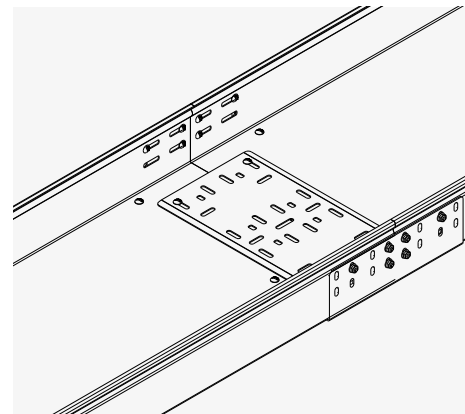
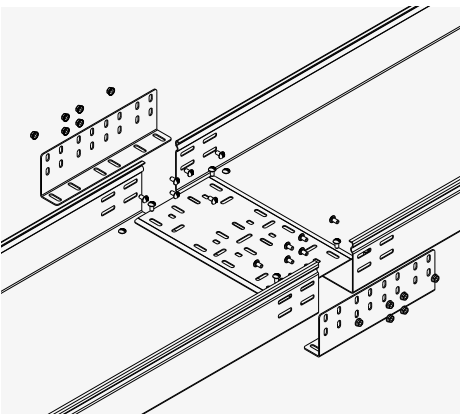

5- DISASSEMBLY AUTOMATIC COUPLER

To disassemble the automatic coupler, it is necessary to pull the key using a screwdriver. After removing the key, the coupler will separate from the cable tray.

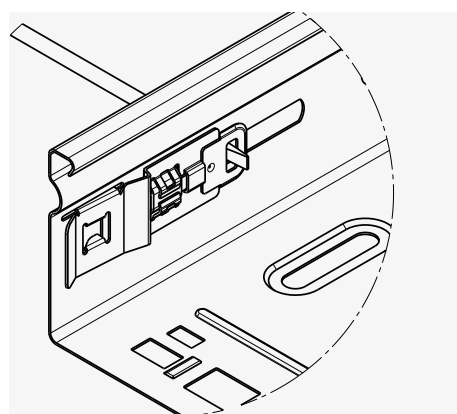
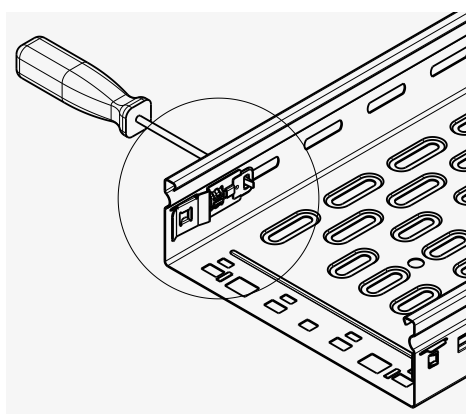

The coupler is not re-usable after the disassembly.

After removing the automatic coupler, the cable tray can be regarded as a standard male-female type.

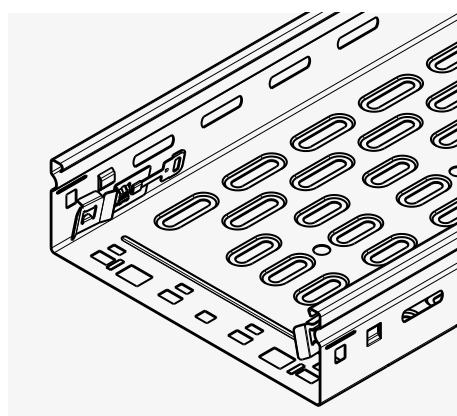
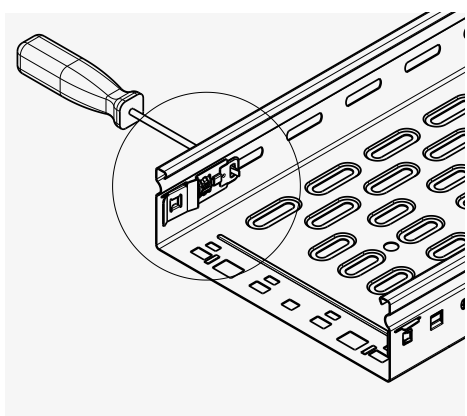

6- LENGTH ASSEMBLING AFTER CUTTING

In this chapter we will show you some different situation of cutting. In order to preserve an integrated coupler it is recommended to cut off the female side when possible. However, in every occasion it is possible to connect cable trays using the appropriate coupler.

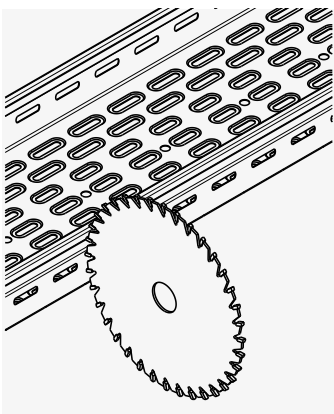

Whenever possible, we recommend to cut cable trays at the index imprinted on the bottom. In this way the hole pattern remaining will be most suitable for connections ensuring a good assembly.

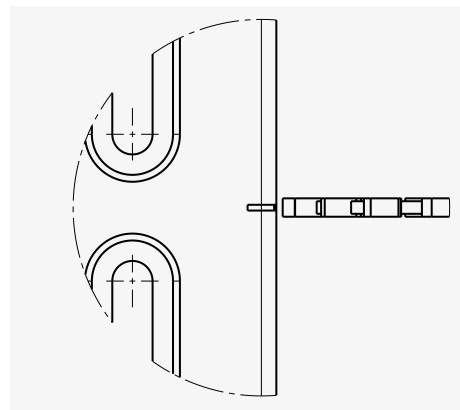
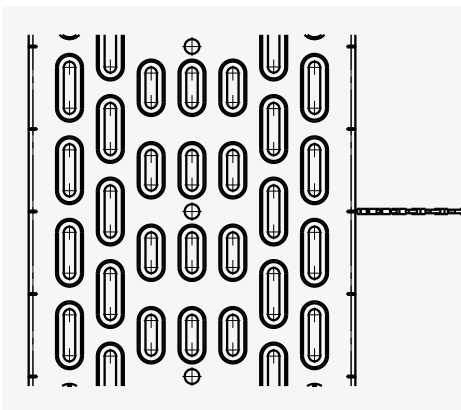

In order to minimise waste, Legrand suggests to cut cable trays only where a fitting is needed, installing the fitting on to the cut-side. On the other side of the fitting, continue installing cable tray starting with the remaining piece, that was cut off before (mounting both cut sides to the fitting). At all times, a cut must be de-burred to avoid danger during installation and damaging cables later.

A- PERFORATED CABLE TRAYS

▪ H25 without female side

Use the holes in the bottom of the male side to install the cut cable tray. Height 25mm in assembled using 3 screws M6x12 on the bottom. The third screw in the middle is optional up to and included width 300mm.

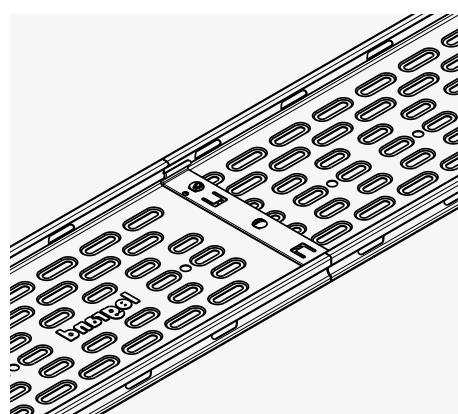
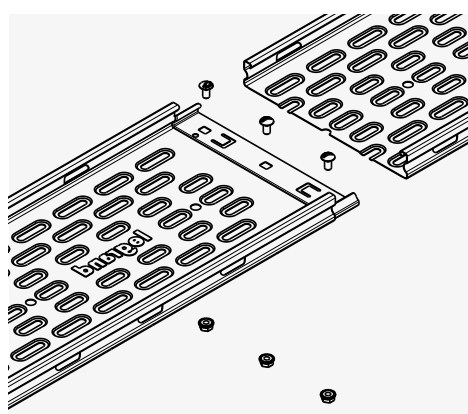

▪ H50-H60 without female side

Use the holes in the bottom of the male side to install the cut cable tray. Height 50 and 60mm are assembled using 3 screws M6x12 on the bottom. The third screw in the middle is optional up to and included width 300mm. Refer to the standard installation for adding the bottom plate on width from 400 to 600mm. If necessary fix the bottom plate using 5 additional screws M6x12.

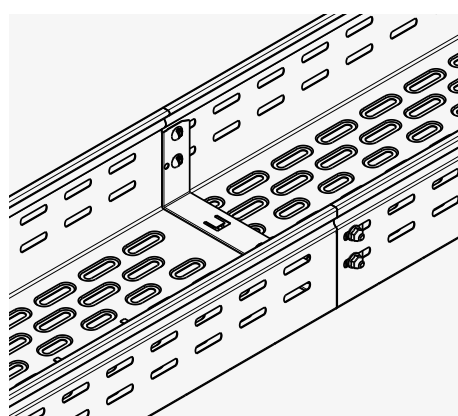
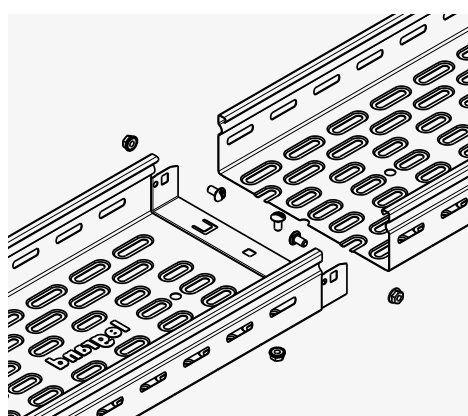

▪ H100 without female side

Use the holes in the bottom of the male side to install the cut cable tray. Height 60mm in assembled using 5 screws M6x12 on the bottom. The third screw in the middle is optional up to and included width 300mm. Refer to the standard installation for adding the bottom plate on width from 400 to 600mm. If necessary fix the bottom plate using 5 additional screws M6x12.

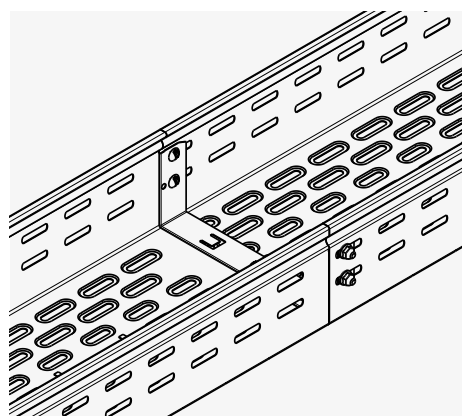
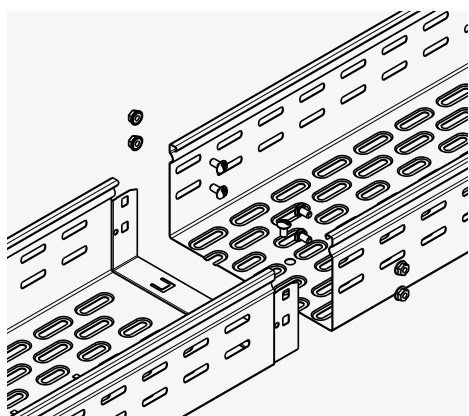

▪ **H25 without male side**

Height 25mm is assembled using two external couplers and 4 screws M6x12 on each coupler.

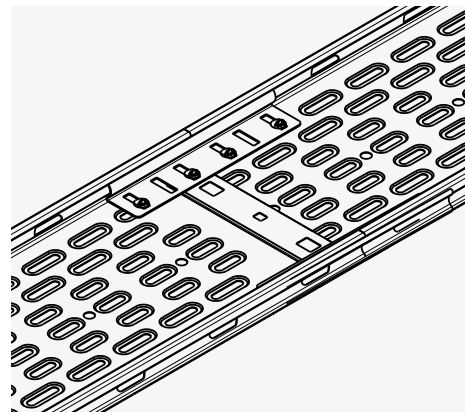
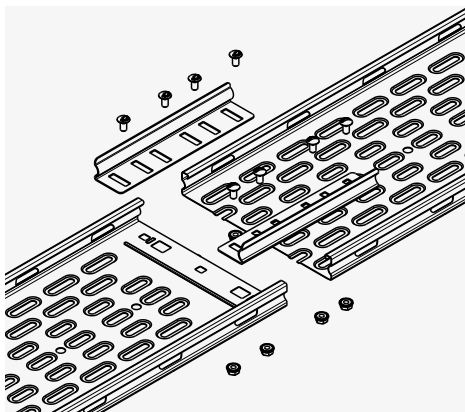
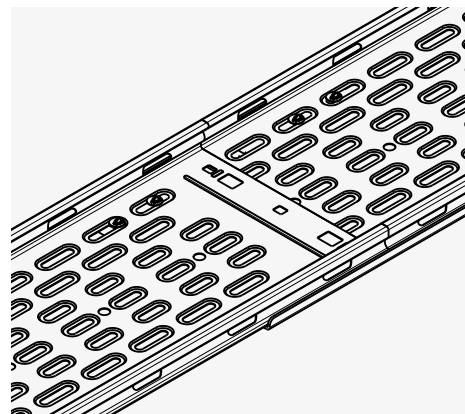
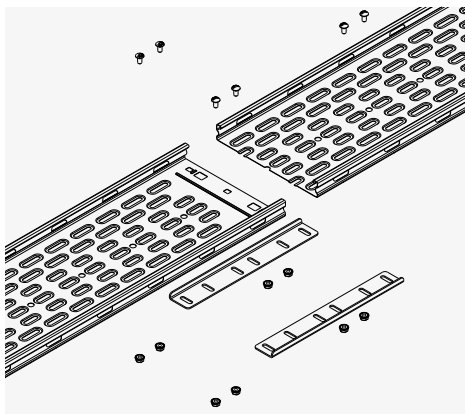

▪ H50-60 without male side

Height 50 and 60mm are assembled using two EDU coupler for the male - female automatic junction without male side. It is not necessary to disassemble the automatic coupler. Use 4 screws M6x12 for each coupler.

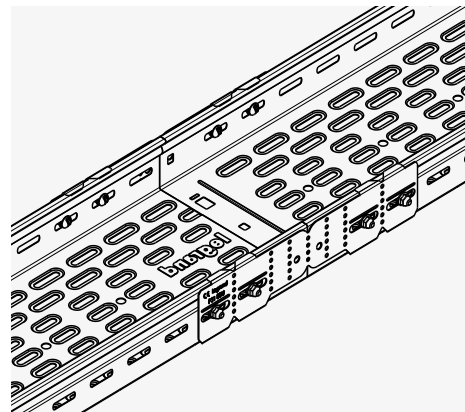
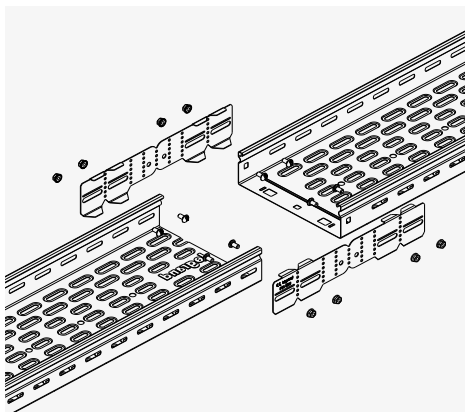

Alternative: use 2pc EP coupler, assembled using 4 screws M6x12 on each coupler.

Removing the auto coupler, if present, is necessary.

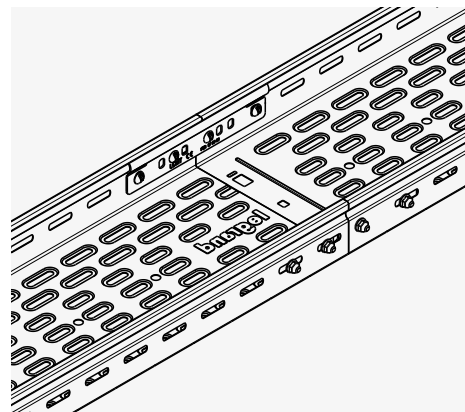
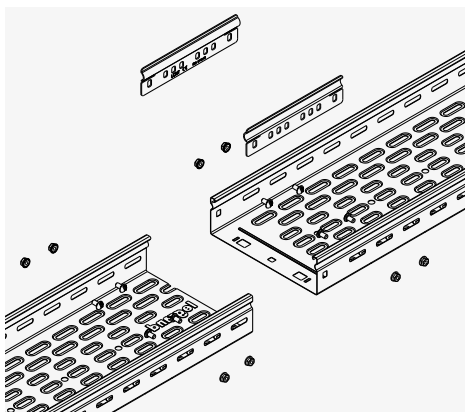

Refer to the standard installation for adding the bottom plate on width from 400 to 600mm.

If necessary fix the bottom plate using 5 additional screws M6x12.

▪ **H100 without male side**

Height 100mm is assembled using two EDU coupler for the male – female junction without male side. Use 8 screws M6x12 for each coupler.

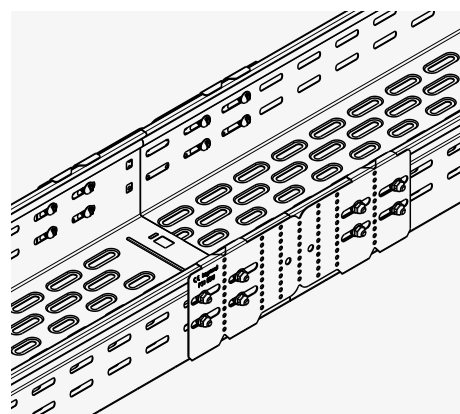
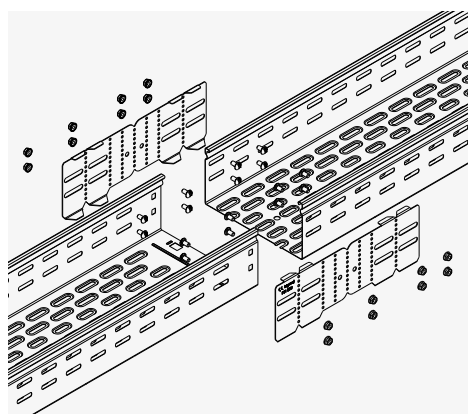

Alternative: use 2pc EP coupler, assembled using 4 screws M6x12 on each coupler.

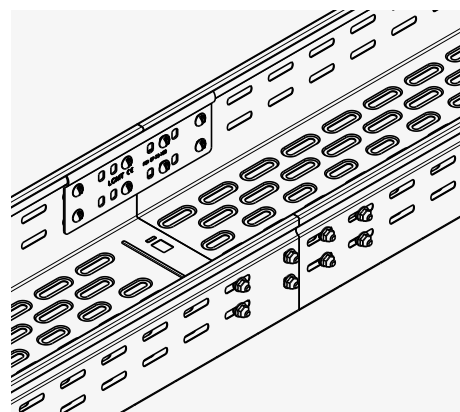
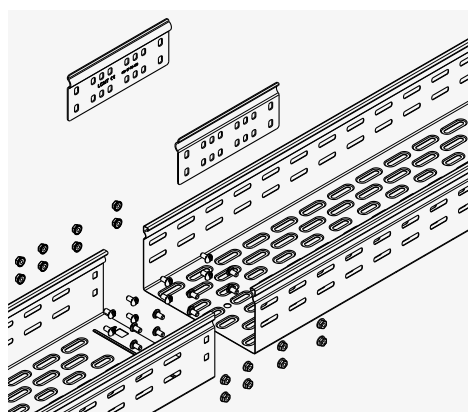

Refer to the standard installation for adding the bottom plate on width from 400 to 600mm.

If necessary fix the bottom plate using 5 additional screws M6x12.

▪ H60 symmetrical cable tray

Height 60mm symmetrical assembled using 2pc Eclic coupler (standard method) is possible if tray(s) have been cut at their markings (see intro chapter 5).

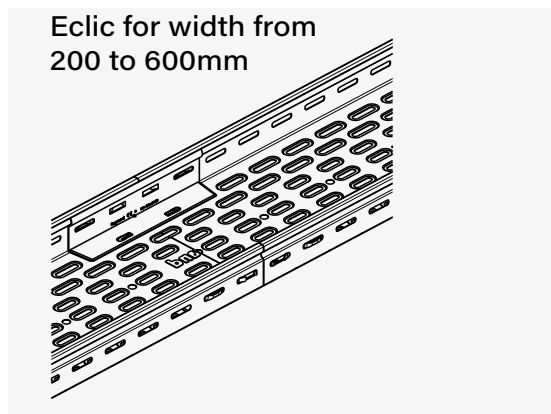
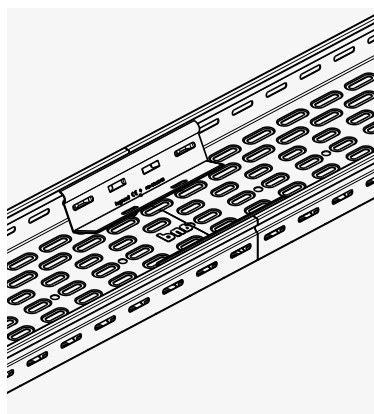
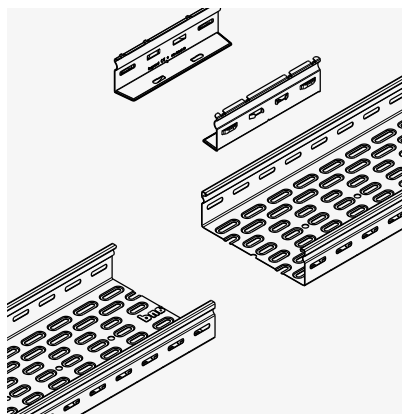

This standard installation is not directly applicable for width from 75 to 150mm.

In this case you have to modify the bottom teeth of the coupler; following the picture below.

Eclic with flattened teeth For W75, 100 and 150mm

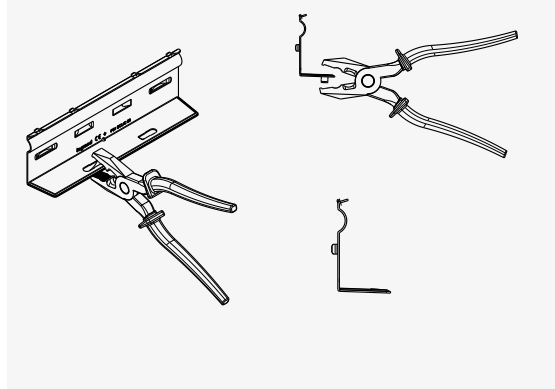

▪ **H60 symmetrical cable tray (continued)**

Width 75mm, 100mm and 150mm in combination with two adjusted Eclis are assembled using 2 screws M6x12 on each coupler.

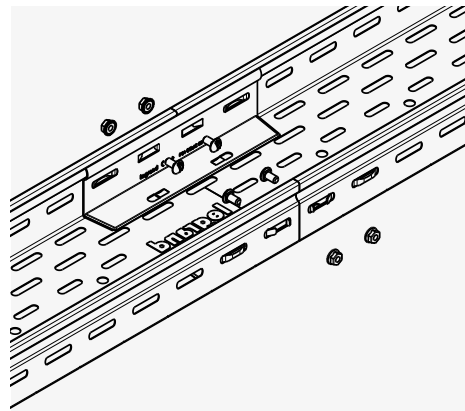
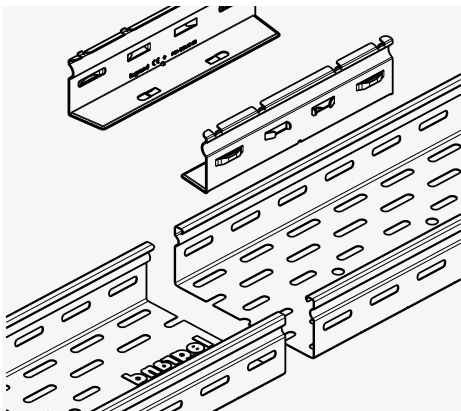

▪ H25 heavy duty cut

The heavy duty versions with cut end(s), are assembled like a standard HD cable tray installation. For height 25mm, use the external coupler with 4 screws M6x12 on each coupler. Put an extra bottom plate on width from 400 to 600mm using 4 additional screws M6x12.

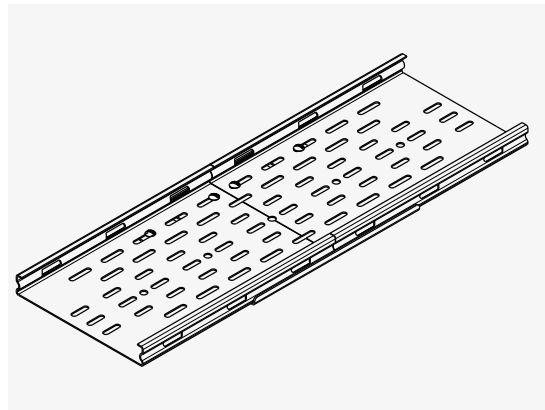
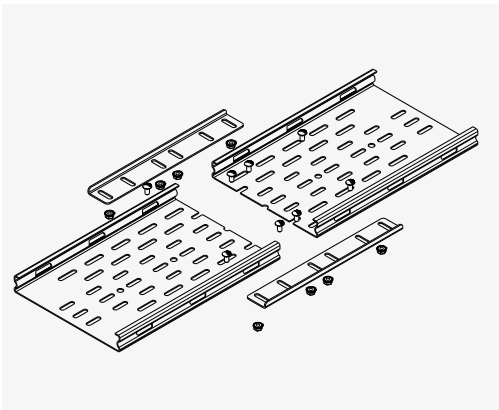

▪ H50-60 heavy duty cut

The heavy duty versions with cut end(s), are assembled like a standard HD cable tray installation. For height 50 and 60mm, use the external coupler with 4 screws M6x12 on each coupler. Put an extra bottom plate on width from 400 to 600mm using 4 additional screws M6x12.

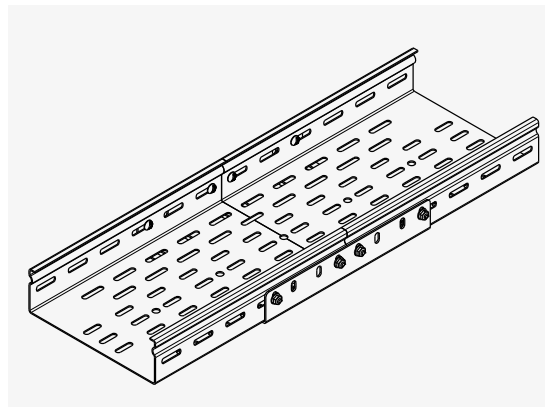
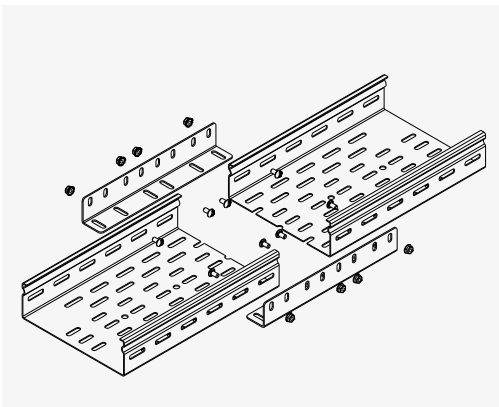

▪ H100 heavy duty cut

The heavy duty versions with cut end(s), are assembled like a standard HD cable tray installation. For height 100mm, use the external coupler with 8 screws M6x12 on each coupler. Put an extra bottom plate on width from 400 to 600mm using 4 additional screws M6x12.

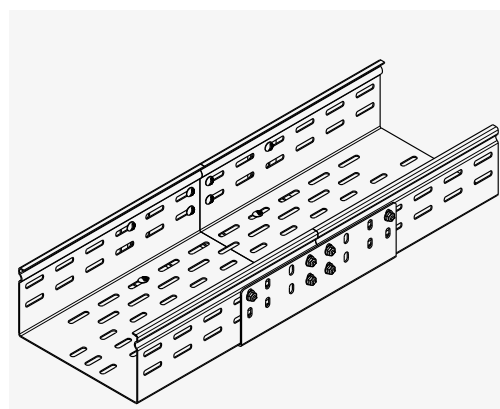
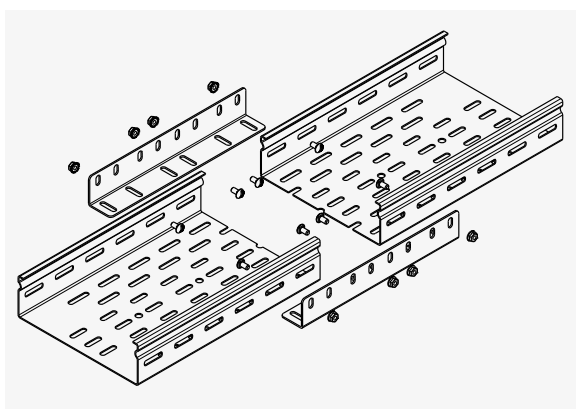

B- BLIND CABLE TRAYS

The Blind cable tray versions with cut end(s), are assembled like a standard cable tray. Holes used to mount external or internal coupler are to be drilled using a 7mm drill if necessary.

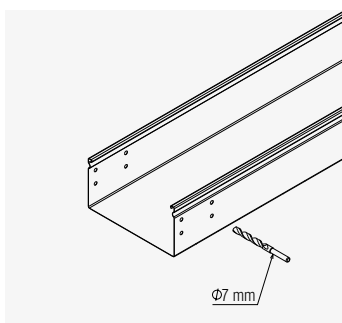

C- RUBBER PROTECTION

Cut cable trays may have sharp edges. To prevent accidents, use protective end-cover. Cut the required length and press over the edge of the cable tray.

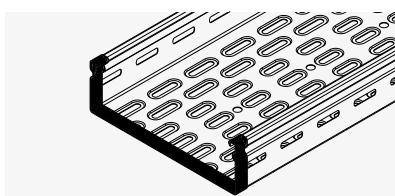
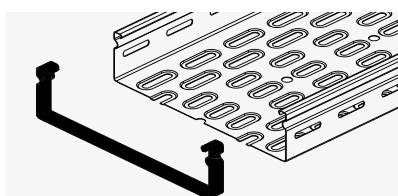

7- P31 COVER LENGTH

A- HORIZONTAL APPLICATION

To mount a cover on a horizontal cable tray, just press until it 'clicks'

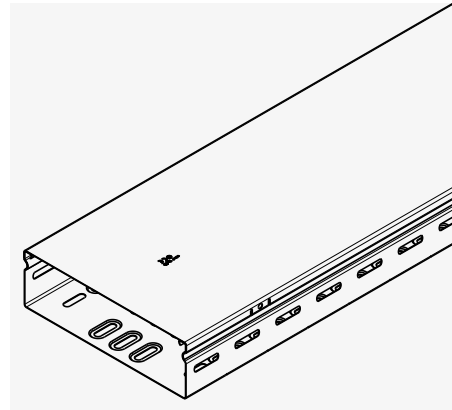
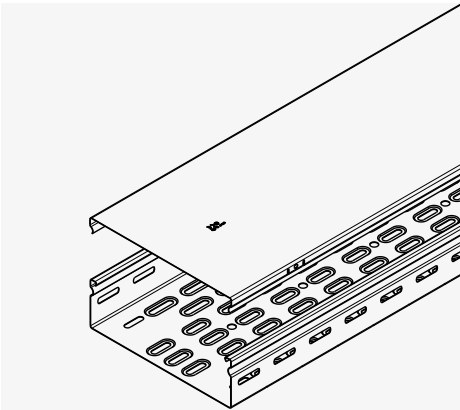

Advise: for outdoor use, add cover clamps: 2pc per meter of cover.

B- VERTICAL APPLICATION

When installing covers on vertical cable trays, work from bottom to top. When disassembling, start at the top working down. Like at horizontal application, the cover can be pressed on.

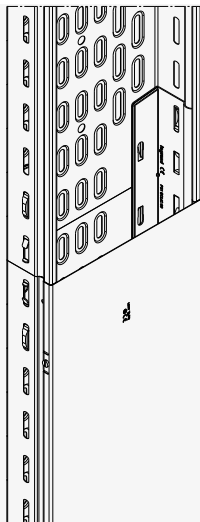
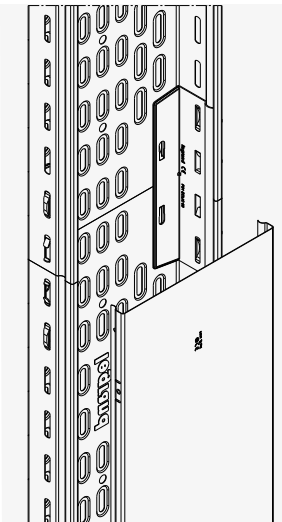

However, if the installation is located in a critical zone, it is important to fix the cover to the tray.

Legrand advises to apply an additional fixing for vertical covers:

- to prevent covers sliding down due to vibrations or removal of bottom cover first
- to make it more difficult for unauthorized people to access the cable tray

A) The first option is using a cover clamp (see chapter C - Clip cover).

B) The second option is to drill a hole using a 4mm diameter drill aligned to the hole in the side of the cover length. Then insert self-tapping screws to fix in position the cover.

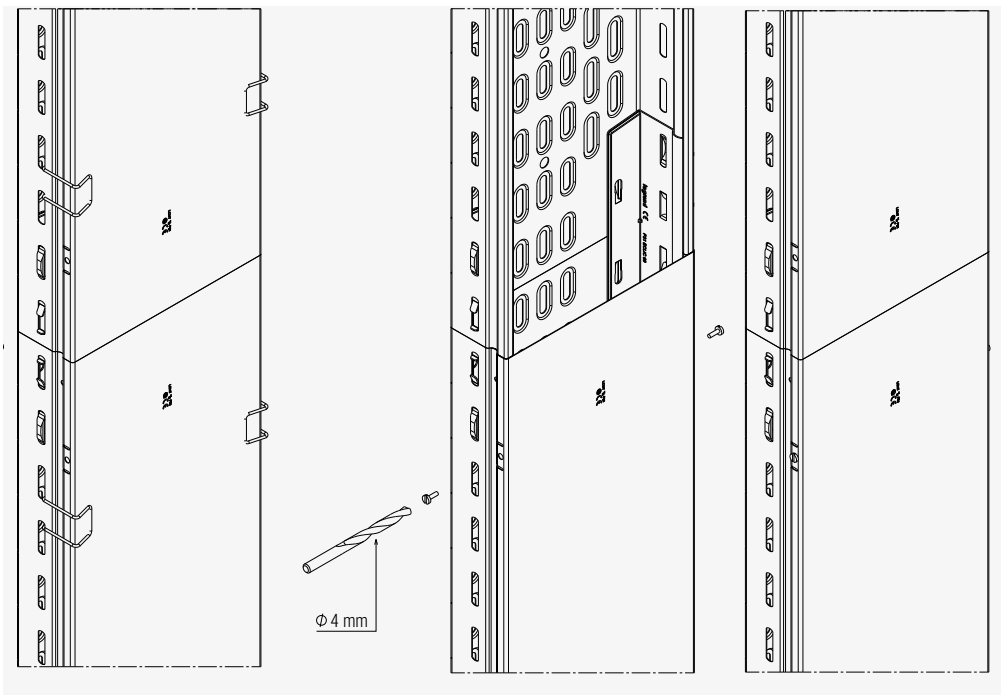

C- CLIP COVER

In case a stronger, more secure fixation is required like in windy places or to resist vibrations, a cover clamp can be used for both horizontal and vertical installations. Cover clamps are easy to spot and re-usable. Suitable for cable trays height 50mm, 60mm and 100mm.

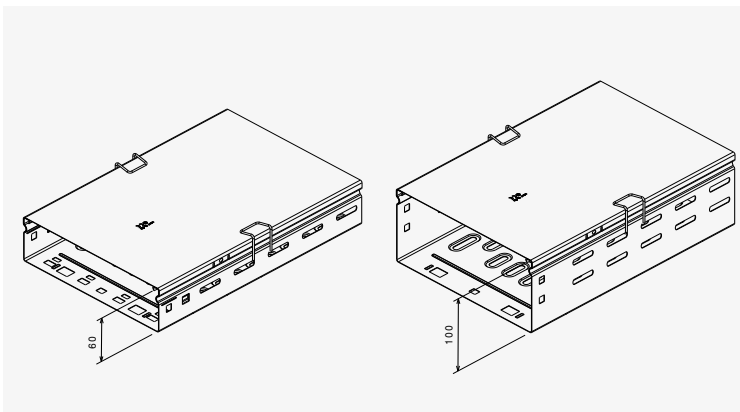

The installation of this clip is very simple. See the pictures below.

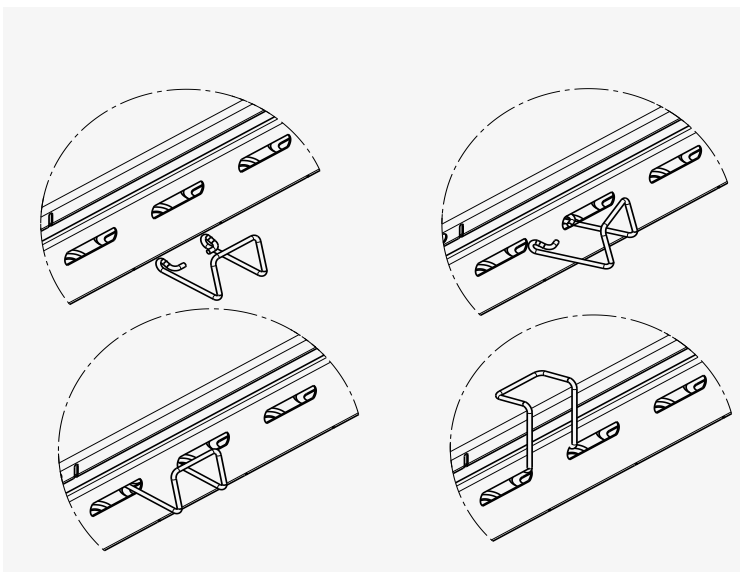

D- ELECTRICAL CONTINUITY FOR COVERS

To guarantee the electrical continuity between covers there is a possibility to joint it using a copper wire. If the cover is devoid of heart connection is necessary to drill a 7mm diameter hole. For painted version remove paint around the hole to assure electric conductivity.

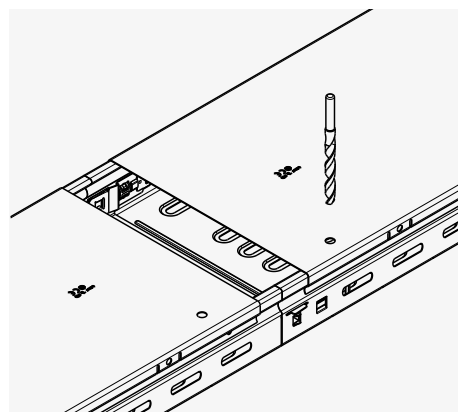
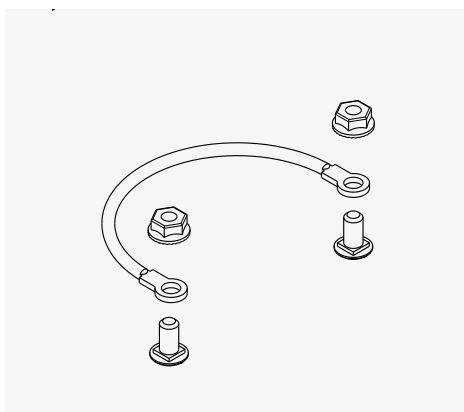

After that fix wire using 2 screws M6x12.

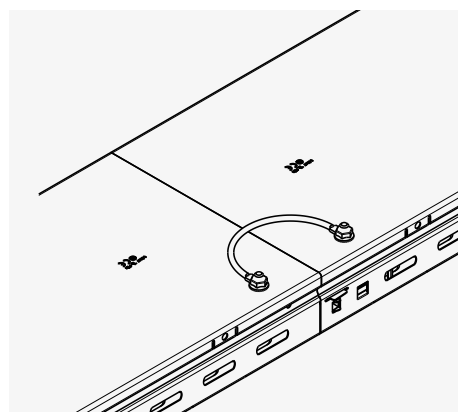
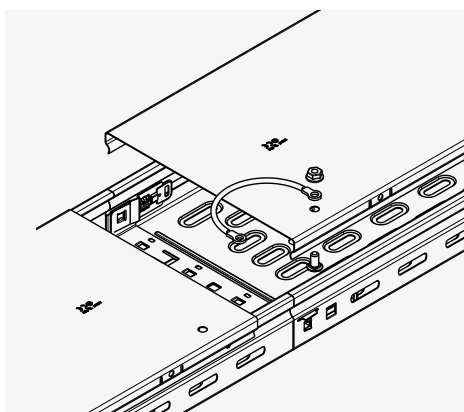

8- INSTALLING A FITTING

A- SLIDE-IN SYSTEM

The fitting will slide over the end of the cable tray. This allows for using both hand to insert screws for the final assembly. Removing an auto coupler (if present) is not necessary.

Fittings will fit on male, female, symmetrical, HD and cut end of a cable tray.

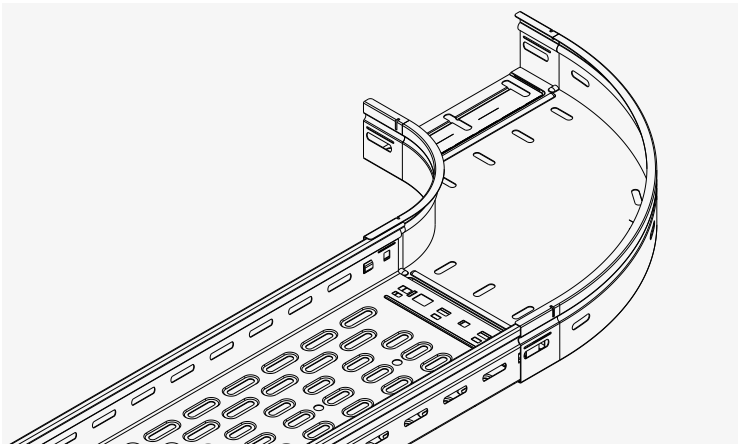

The final position of the fitting can be slightly adjusted before tightening the screws. There are 15mm of adjustment.

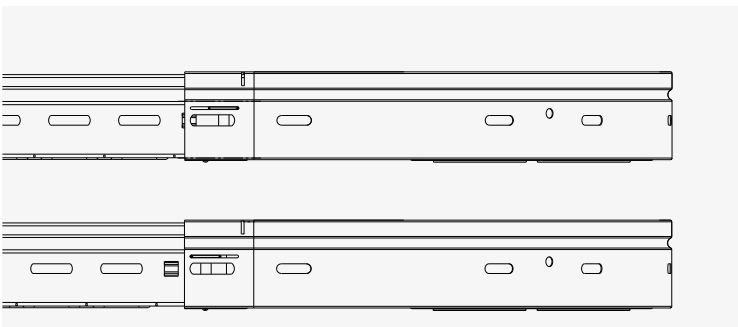

In case a cut is not perfectly perpendicular to the length of the cable tray, most fittings will hide this from view after installation.

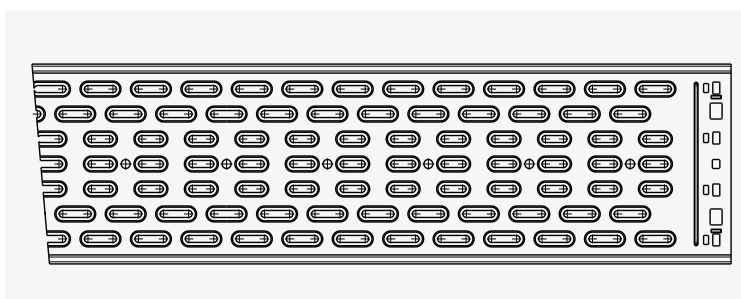

Top view of diagonal cut in the picture below.

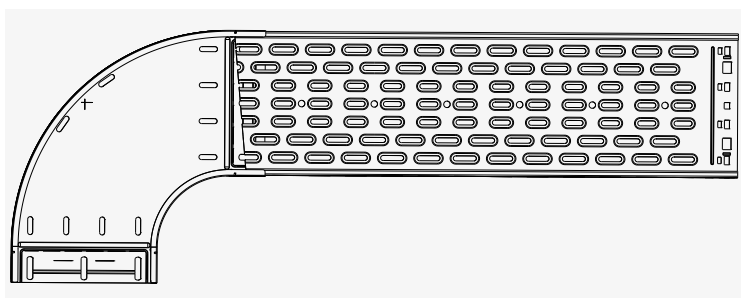

Bottom view of diagonal cut in the picture below.

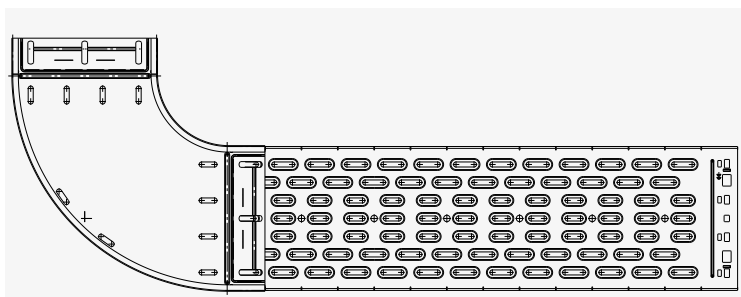

Improvements introduced in the fittings with the introduction of New P31+

- 1) Extra perforation in the bottom and outside corner to fix cables for easier pulling and better organizing (Strap first cable to outside of corner, so cables added later will slide easily along the inside corner).
- 2) The tiny embossing on the side prevent cable trays from being inserted too far. (And avoid danger at pulling cables)
- 3) The perpendicular embossing that cross the section of fitting lifts the cable and reduces the possibility of damage when pulling them.
- 4) The incision on the high side of the fitting allows hooking a spring-mate rule to measure the distance to the next connection = the length of cable tray needed.

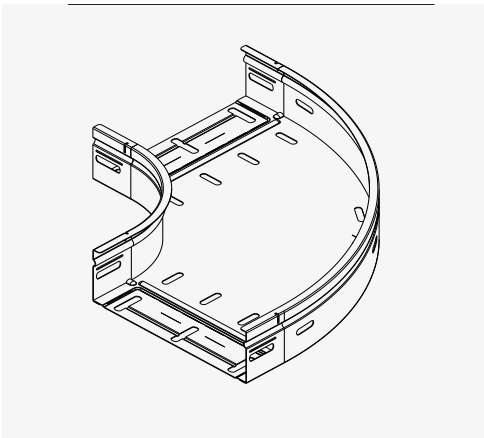

B- FLAT BEND 90°

▪ H25

Flat bend height 25mm is assembled using 6 screws M6x12 on the bottom. The third screw in the middle is optional up to and included width 300mm. For painted version put the third screw in the middle for all widths to assure electric conductivity.

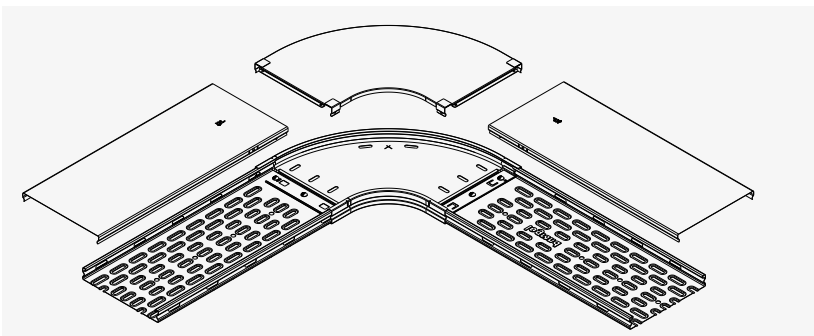

▪ H25 (continued)

In case of covers, first fix the cover on the fitting before fitting the cover lengths.

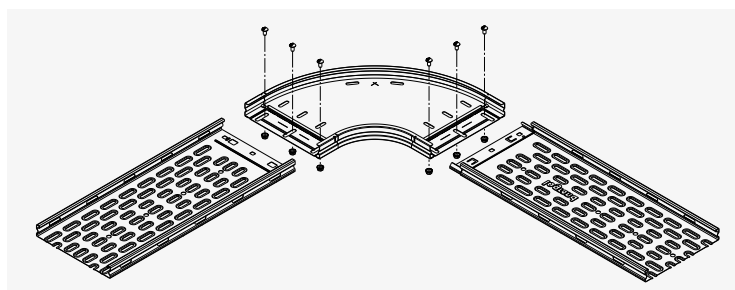

▪ H50-60

Flat bend height 50 and 60mm are assembled using 6 screws M6x12 on the side and on the bottom. The third screw in the middle is optional up to and included width 300mm. For painted version put the third screw in the middle for all widths to assure electric conductivity.

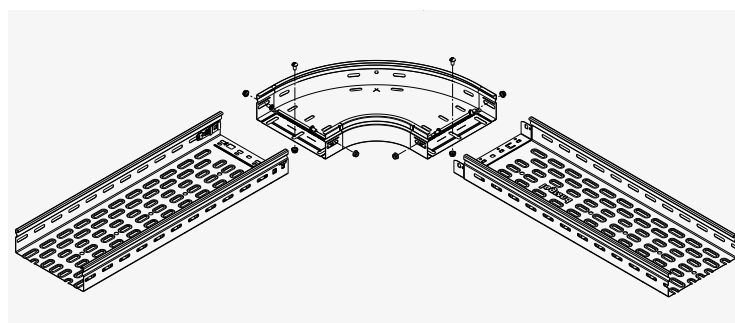

In case of covers, first fix the cover on the fitting before fitting the cover lengths. Optional for width from 400mm to 600mm: use the hole $\varnothing 7$ mm in the middle of the outer side wall to create an extra suspension for more rigidity.

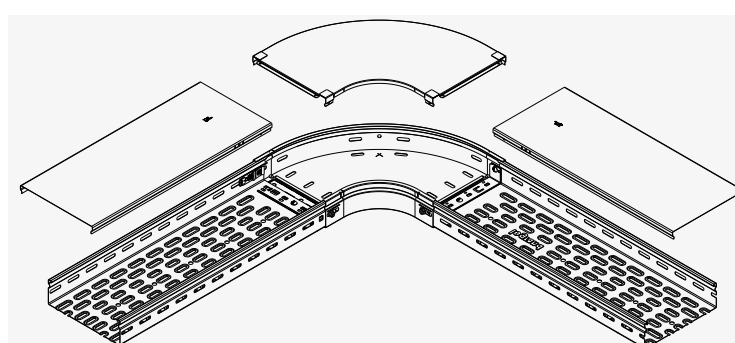

▪ **H100**

Flat bend height 100mm is assembled using 10 screws M6x12 on the side and on the bottom. The screw in the middle is optional up to and included width 300mm. For painted version put the third screw in the middle for all widths to assure electric conductivity.

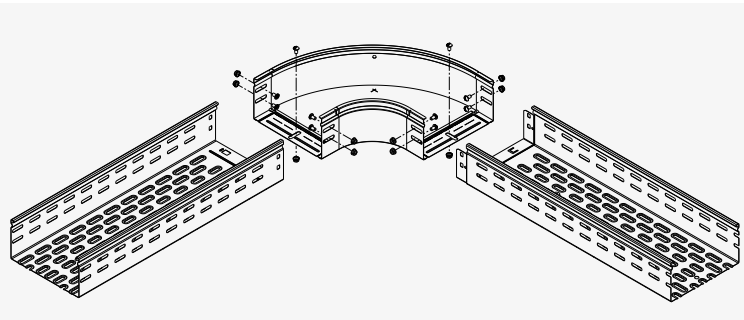

In case of covers, first fix the cover on the fitting before fitting the cover lengths. Optional for width from 400mm to 600mm: use the hole $\varnothing 7\text{mm}$ in the middle of the outer side wall to create an extra suspension for more rigidity.

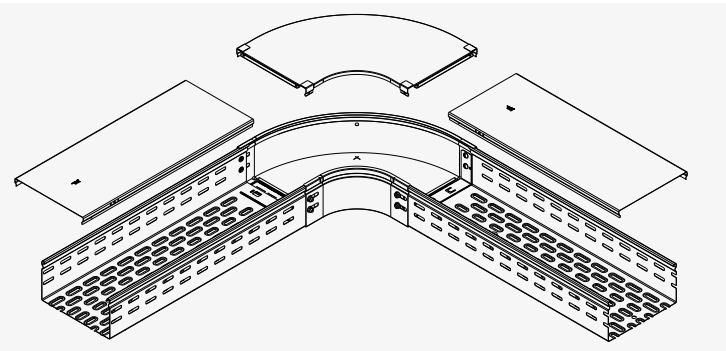

C- FLAT BEND 45°

▪ H25

Flat bend height 25mm is assembled using 6 screws M6x12 on the bottom. The third screw in the middle is optional up to and included width 300mm. For painted version put the third screw in the middle for all widths to assure electric conductivity.

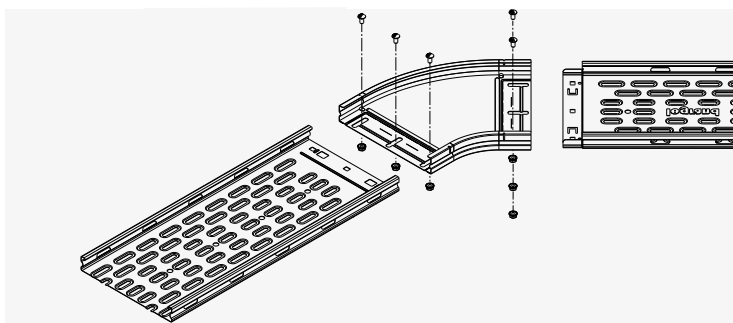

In case of covers, first fix the cover on the fitting before fitting the cover lengths.

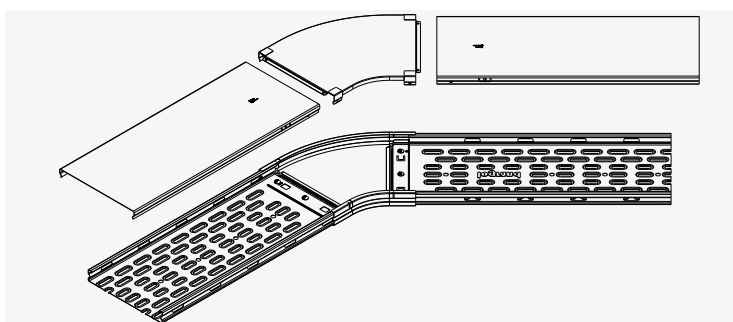

▪ H50

Flat bend height 50mm is assembled using 6 screws M6x12 on the side and on the bottom. The third screw in the middle is optional up to and included width 300mm. For painted version put the third screw in the middle for all widths to assure electric conductivity.

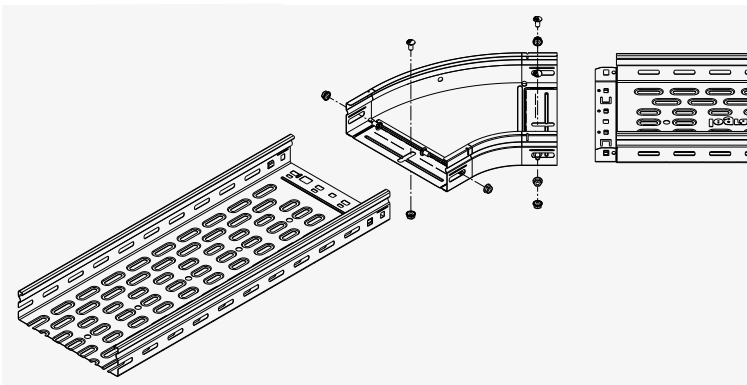

In case of covers, first fix the cover on the fitting before fitting the cover lengths. Optional for width from 400mm to 600mm: use the hole $\varnothing 7\text{mm}$ in the middle of the outer side wall to create an extra suspension for more rigidity.

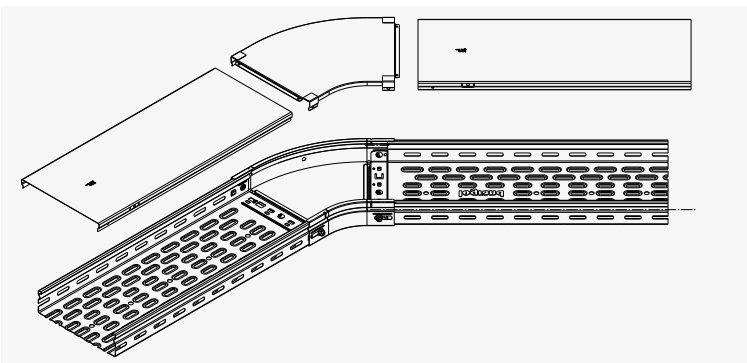

▪ H100

Flat bend height 100mm is assembled using 10 screws M6x12 on the side and on the bottom. The screw in the middle is optional up to and included width 300mm. For painted version put the third screw in the middle for all widths to assure electric conductivity.

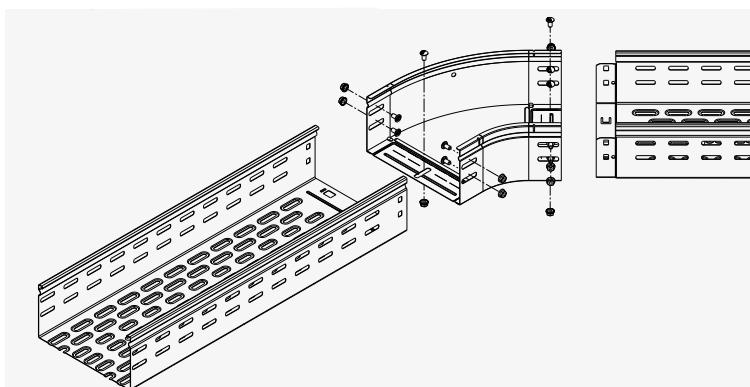

In case of covers, first fix the cover on the fitting before fitting the cover lengths. Optional for width from 400mm to 600mm: use the hole $\varnothing 7\text{mm}$ in the middle of the outer side wall to create an extra suspension for more rigidity.

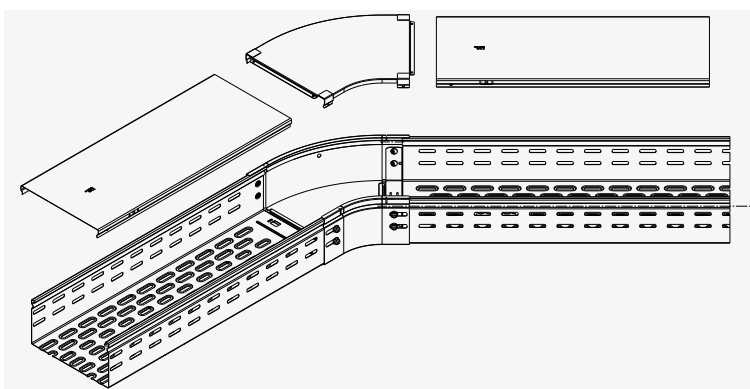

D- ADJUSTABLE FLAT BEND

▪ H60

The adjustable flat bend is available only in height 60mm. It is assembled using 6 screws M6x12 on the side and on the bottom.

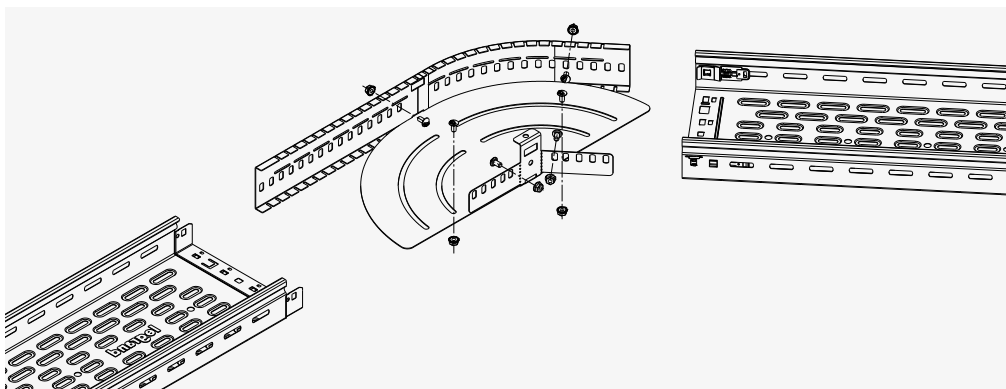

You can adjust the angle of bending from 0 to 100° (50° for both sides).

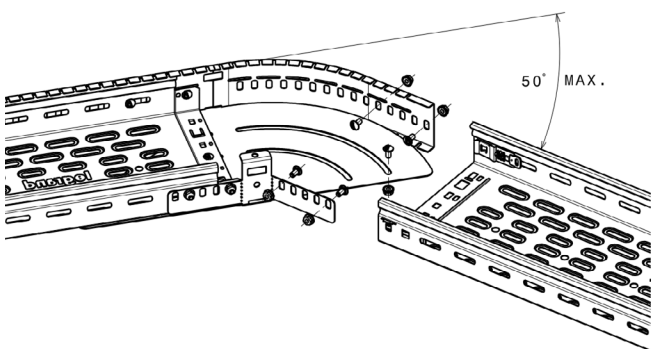

▪ **H60 (continued)**

Fix the 3 screws per side in the free holes that you find on the side and bottom.

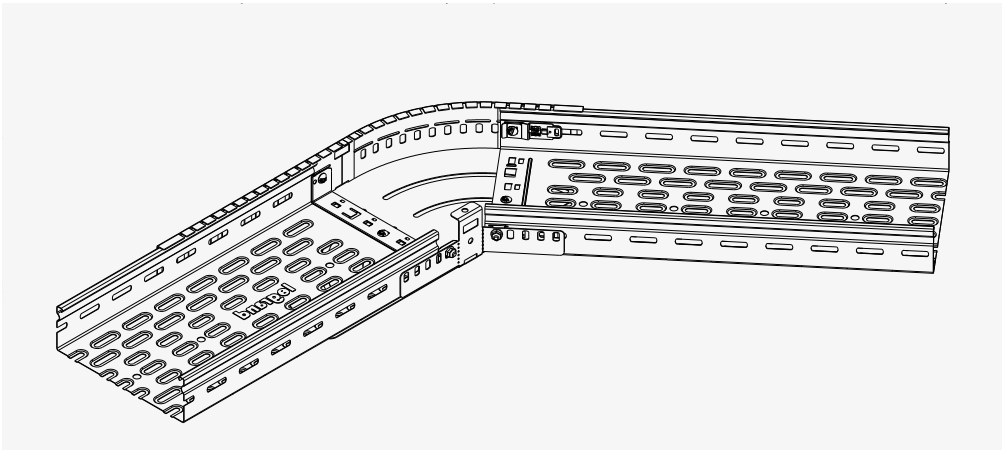

In case of covers, first fix the cover on the fitting before fitting the cover lengths.

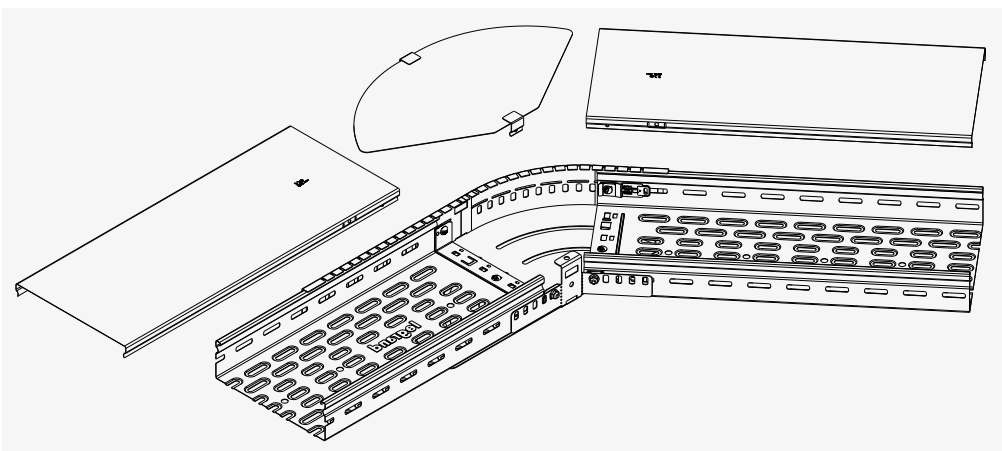

E- EQUAL TEE

▪ H25

Equal tee in height 25mm is assembled using 9 screws M6x12 on the bottom. The third screw in the middle is optional up to and included width 300mm. For painted version put the third screw in the middle for all widths to assure electric conductivity.

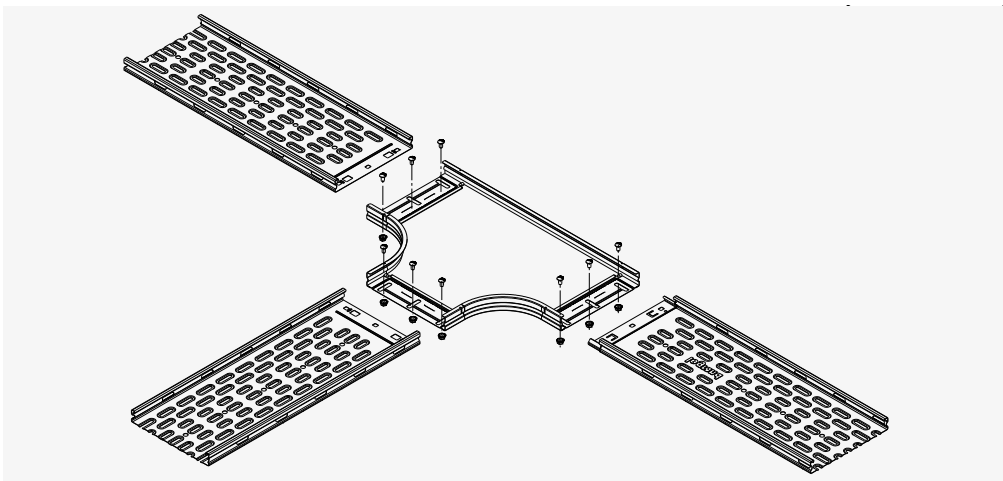

In case of covers, first fix the cover on the fitting before fitting the cover lengths. Optional for width from 400mm to 600mm: use the hole $\varnothing 7\text{mm}$ in the middle of the outer side wall to create an extra suspension for more rigidity.

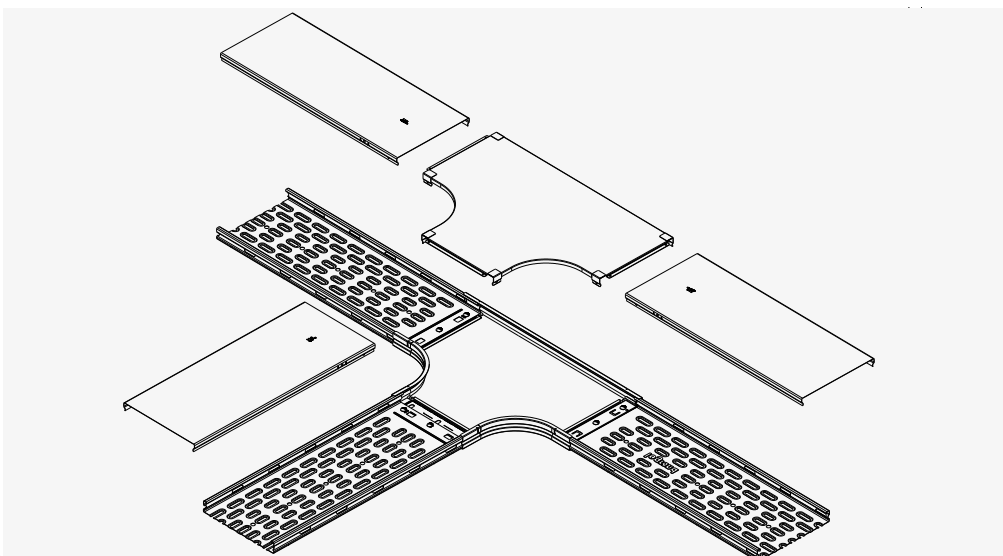

▪ H50-60

Equal tee in height 50 and 60mm are assembled using 9 screws M6x12 on the side and on the bottom. The third screw in the middle is optional up to and included width 300mm. For painted version put the third screw in the middle for all widths to assure electric conductivity.

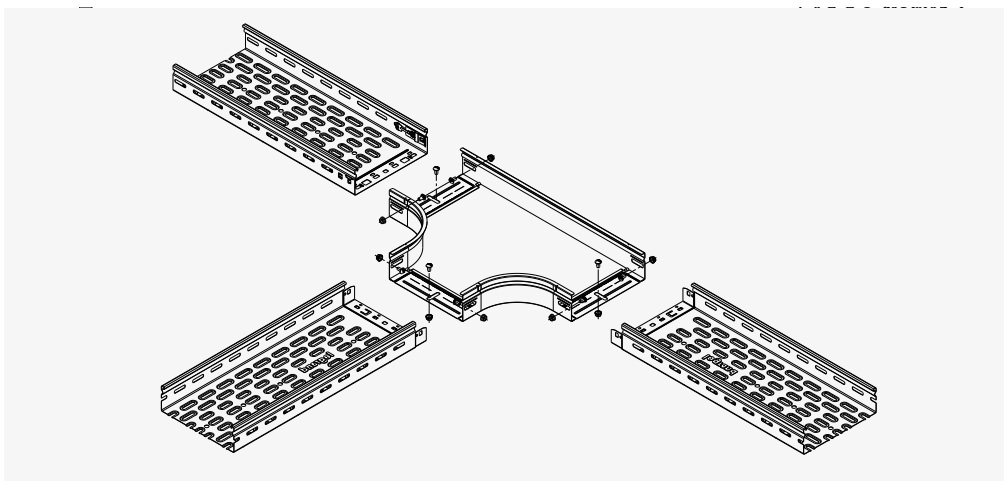

In case of covers, first fix the cover on the fitting before fitting the cover lengths. Optional for width from 400mm to 600mm: use the hole $\varnothing 7$ mm in the middle of the outer side wall to create an extra suspension for more rigidity.

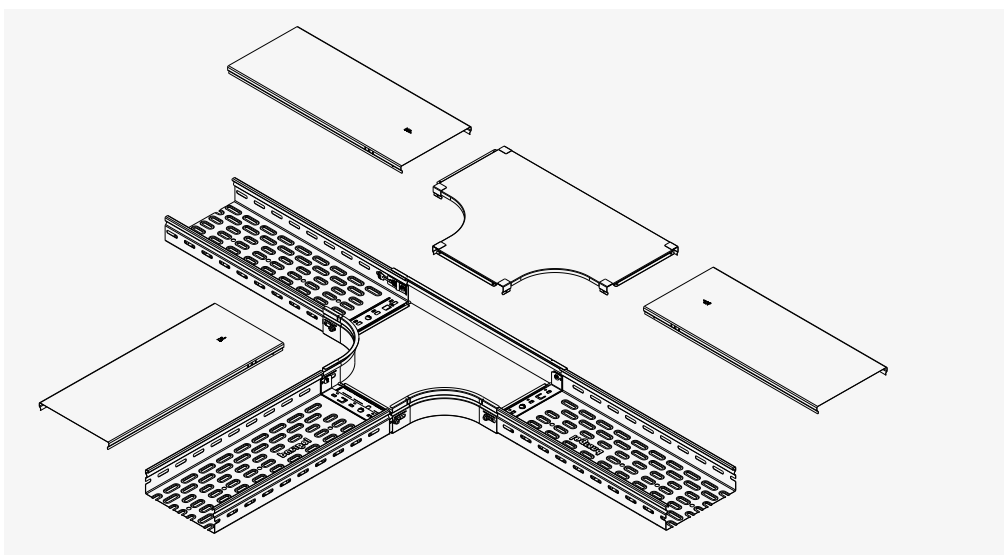

F- 4WAY

▪ H25

4 way in height 25mm is assembled using 12 screws M6x12 on the bottom. The third screw in the middle is optional up to and included width 300mm. For painted version put the third screw in the middle for all widths to assure electric conductivity.

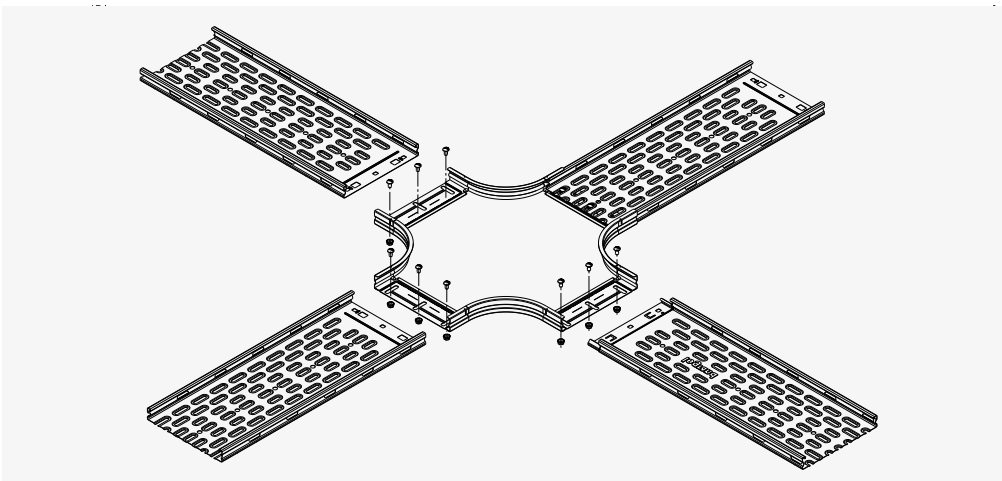

In case of covers, first fix the cover on the fitting before fitting the cover lengths. Optional for width from 400mm to 600mm: use the hole $\varnothing 7\text{mm}$ in the middle of the outer side wall to create an extra suspension for more rigidity.

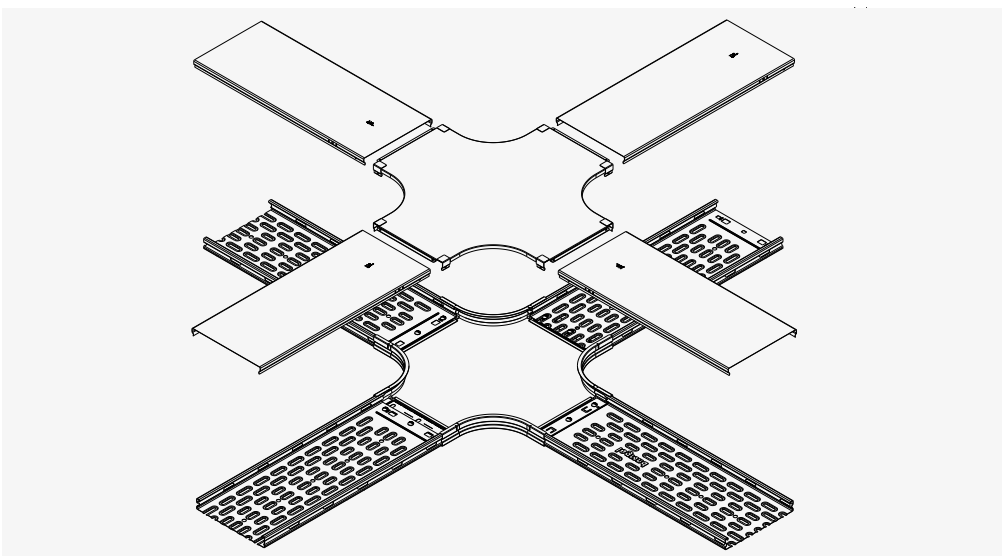

▪ **H50**

4 way in height 50mm is assembled using 12 screws M6x12 on the side and on the bottom. The third screw in the middle is optional up to and included width 300mm. For painted version put the third screw in the middle for all widths to assure electric conductivity.

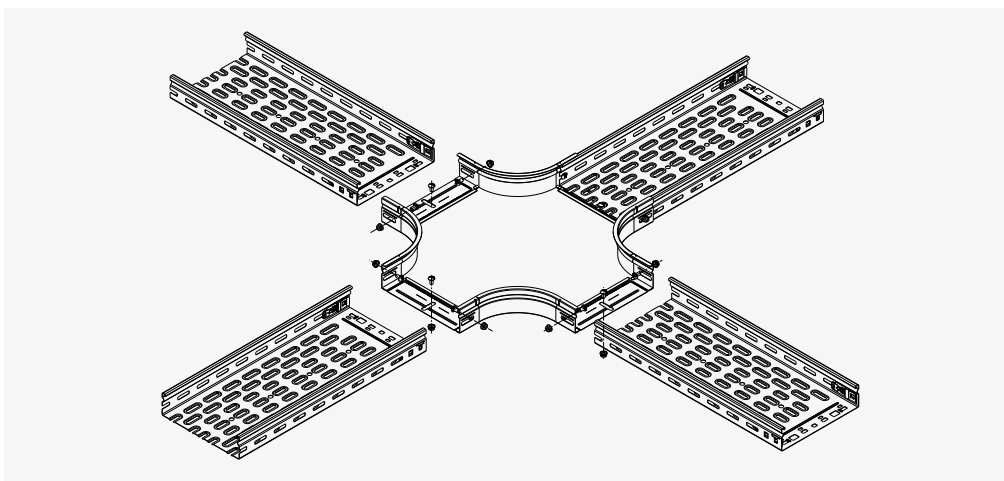

In case of covers, first fix the cover on the fitting before fitting the cover lengths. Optional for width from 400mm to 600mm: use the hole $\varnothing 7$ mm in the middle of the outer side wall to create an extra suspension for more rigidity.

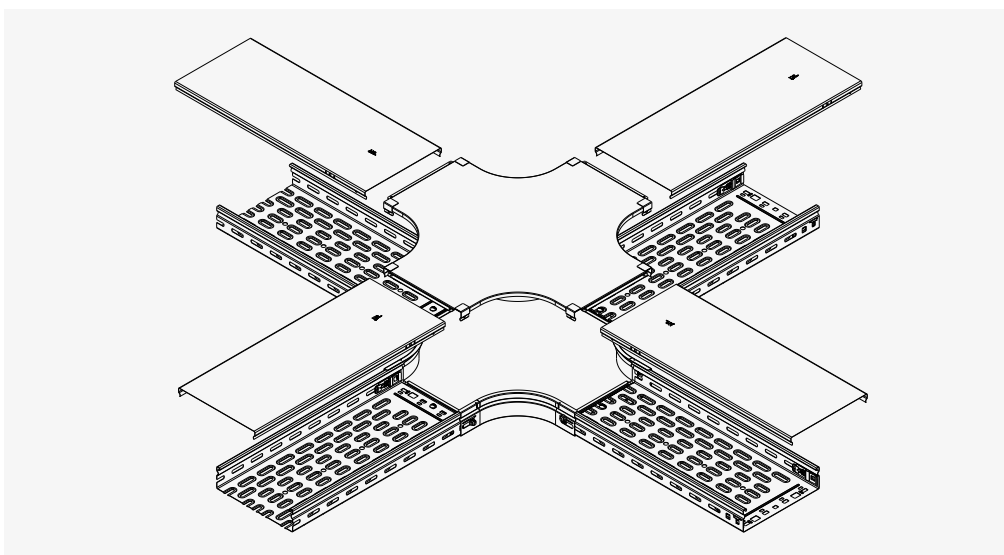

▪ H100

4 way in height 100mm is assembled using 20 screws M6x12 on the side and on the bottom. The third screw in the middle of the bottom is an optional on width until 300mm included. For painted version put the third screw in the middle for all widths to assure electric conductivity.

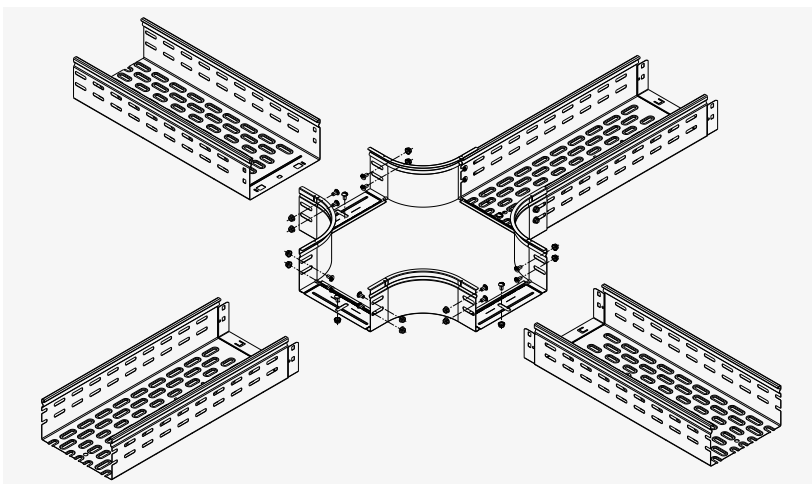

In case of covers, first fix the cover on the fitting before fitting the cover lengths. Optional for width from 400mm to 600mm: use the hole $\varnothing 7\text{mm}$ in the middle of the outer side wall to create an extra suspension for more rigidity.

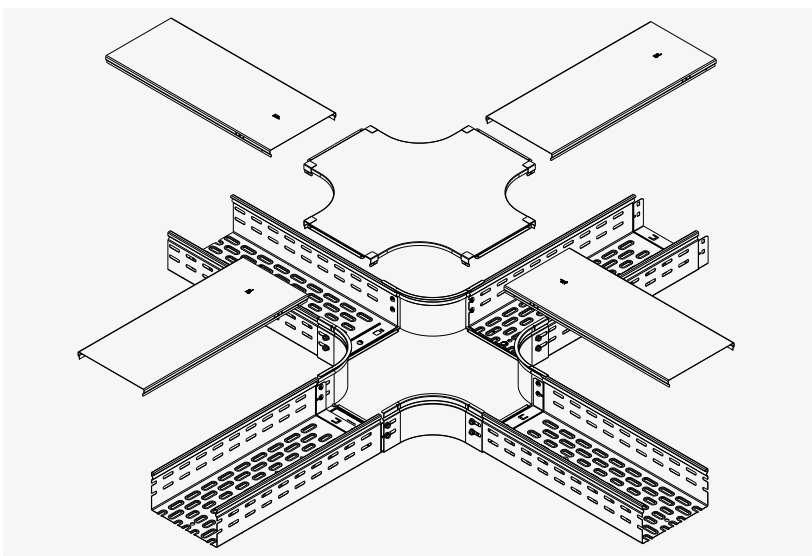

G- T-BRANCH

To install the T-Branch fitting, cut the side of the cable tray. Find the right measure to cut in the pictures below. "W" stands for the width of cable tray that you want to install as a branch.

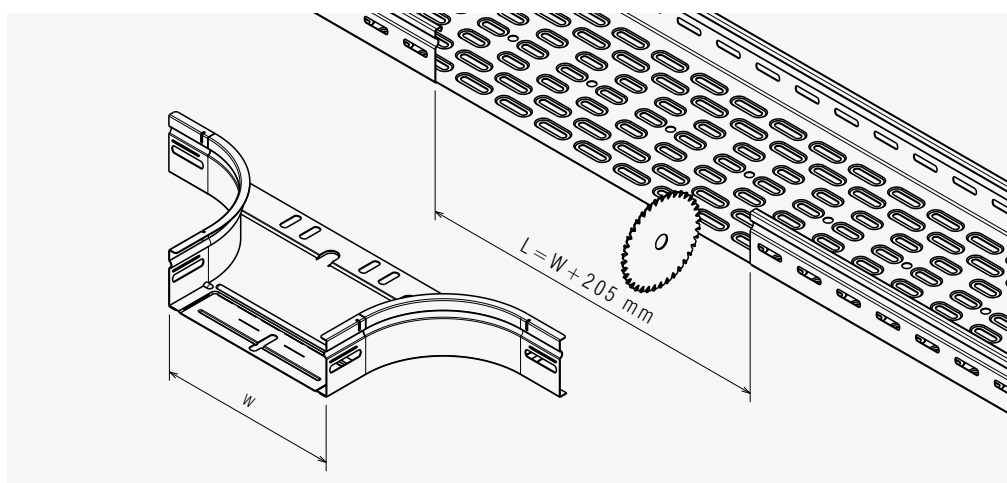

By positioning the T-Branch, it is important to put the wings under the bottom of the cable tray for extra support.

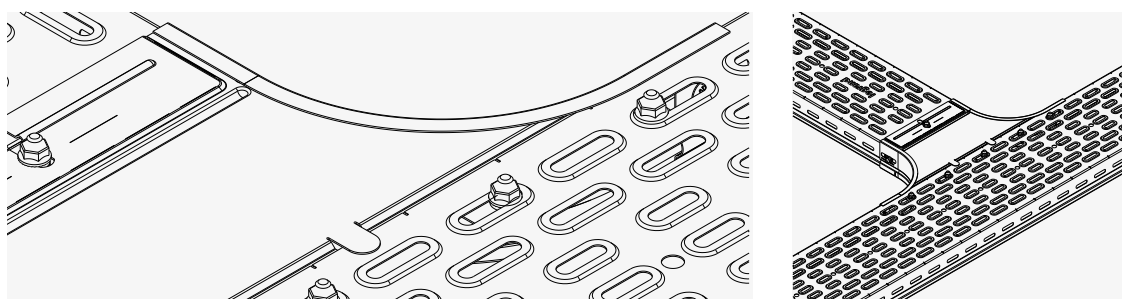

Find the right measure to cut the cover in the pictures below. "W" stands for the width of cable tray that you want to install as a branch.

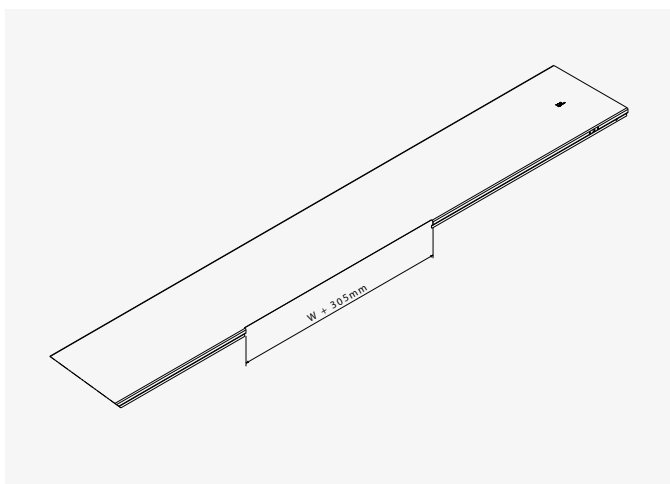

In case of covers, first fix the cover on the straight length, then the fitting and finally the branching cable tray.

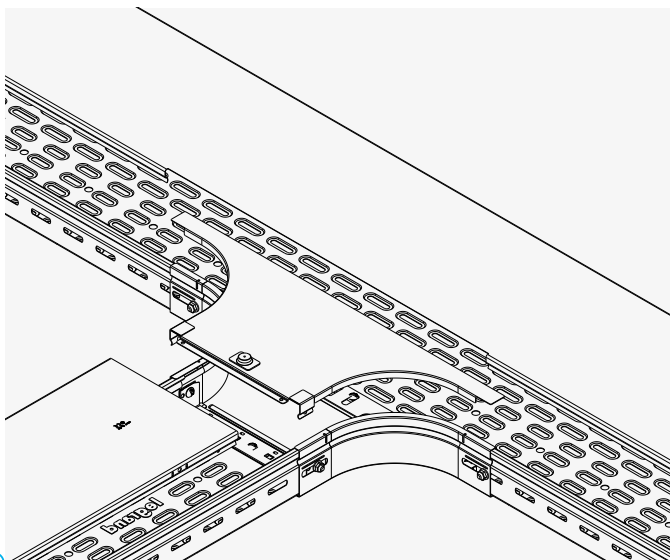

Below there is the table with the number of screws M6x12 needed to install Branch Piece.

Width Cable tray	# Screws M6x12		
	'X'	'Y'	'Z'
75	4	6	10
100	4	6	10
150	5	7	11
200	6	8	12
300	6	8	12
400	7	9	13
500	9	11	15
600	9	11	15

For painted version put the screws on the bottom for all widths to assure electric conductivity, on both entrance. In this case add 2 screws on the recommended number showed in the table above.

▪ **H25**

T-Branch in height 25mm is assembled using "X" (See chapter G - page 61) screws M6x12 on the bottom.

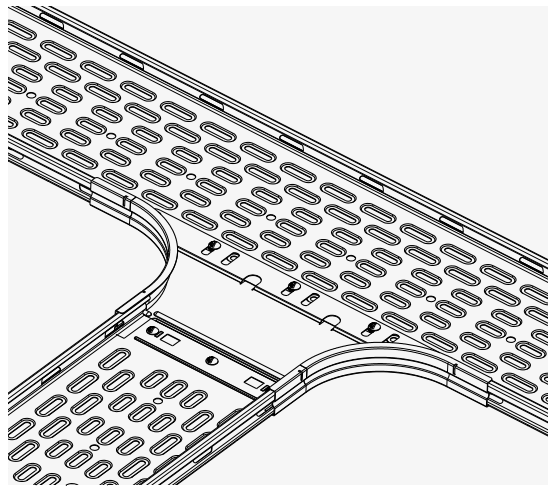
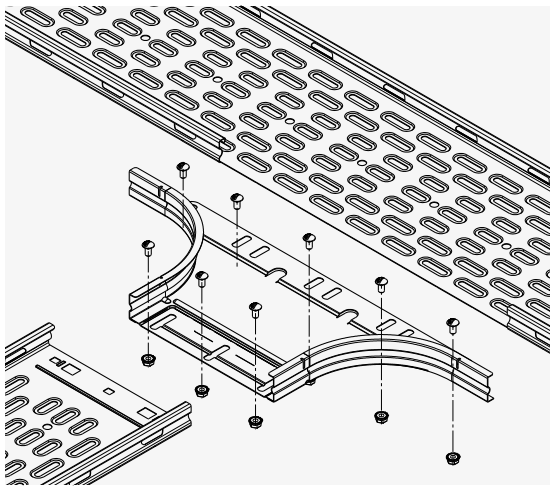

▪ **H50-60**

T-Branch in height 50 and 60mm are assembled using "Y" (See chapter G - page 61) screws M6x12 on bottom and sides.

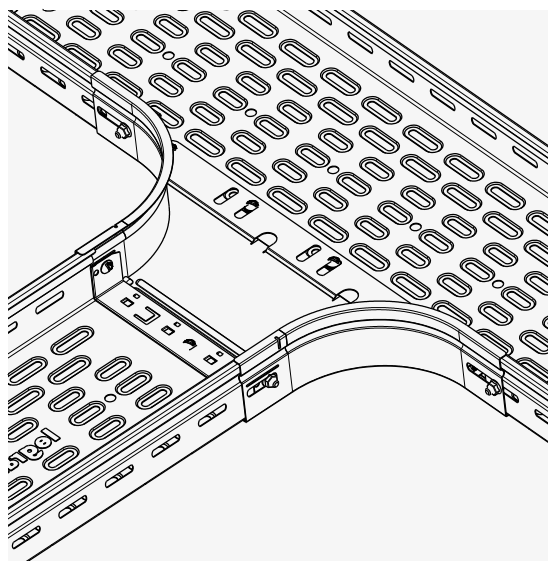
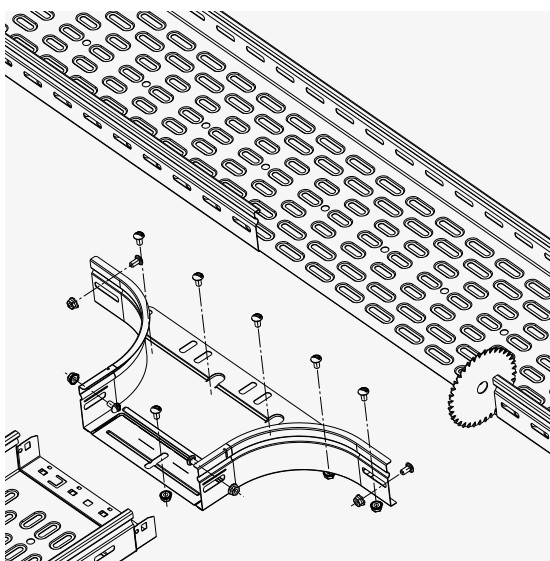

▪ H100

T-Branch in height 100mm is assembled using "Z" (See chapter G -page 61) screws M6x12 on bottom and sides.

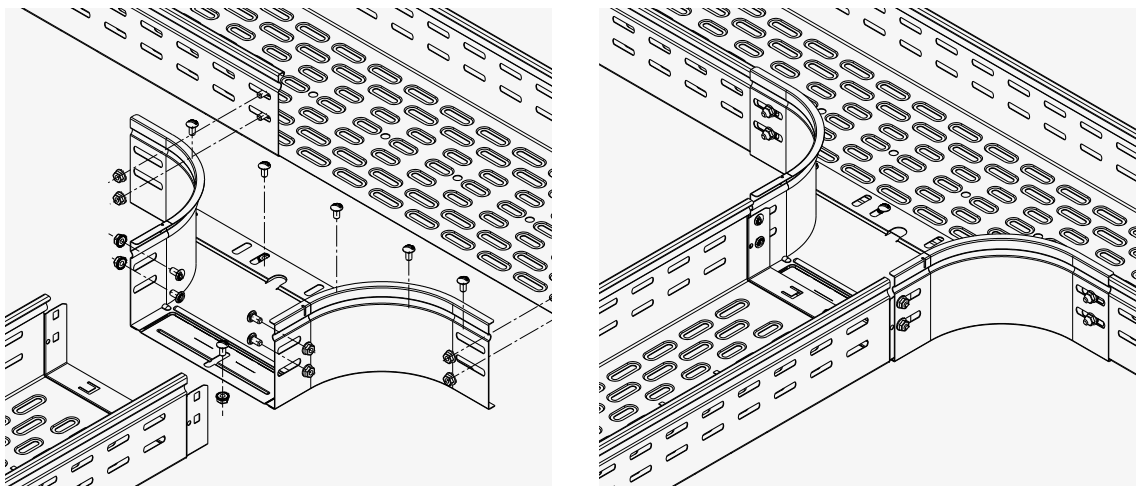

H- UNIVERSAL BRANCH

▪ H60

To install the universal branch piece, cut the sides of the cable trays. This fitting is available only in height 60mm. Find the right measure to cut for the side of cable trays and covers in the pictures below. "W" stands for the width of cable tray that you want to install as a branch.

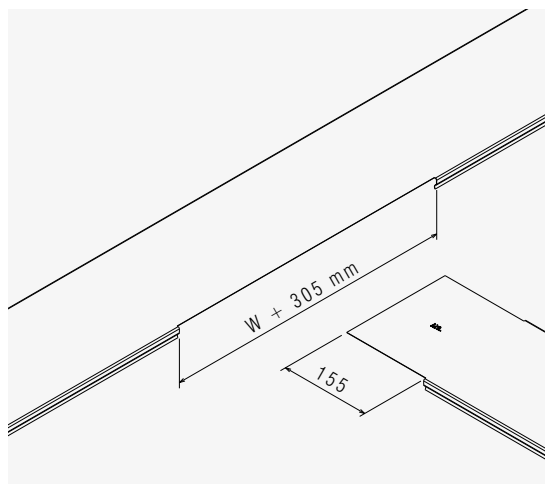
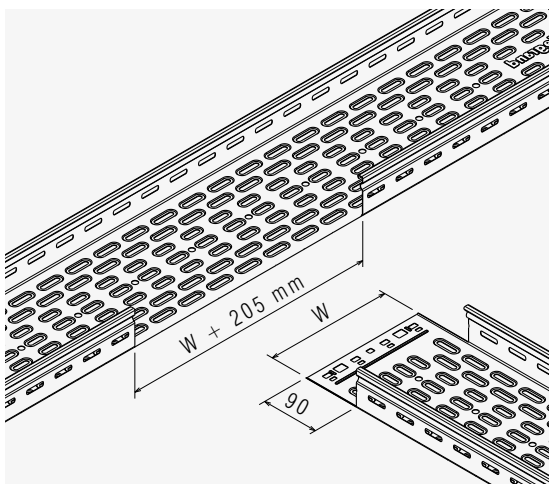

▪ H60 (continued)

T-Branch in height 25mm is assembled using "X" (See chapter G - page 61) screws M6x12 on the bottom.

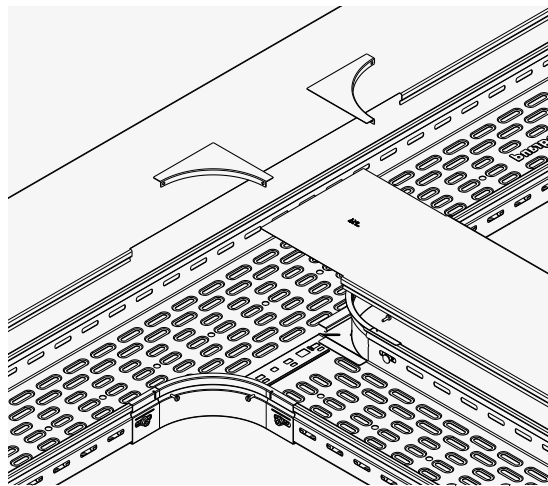
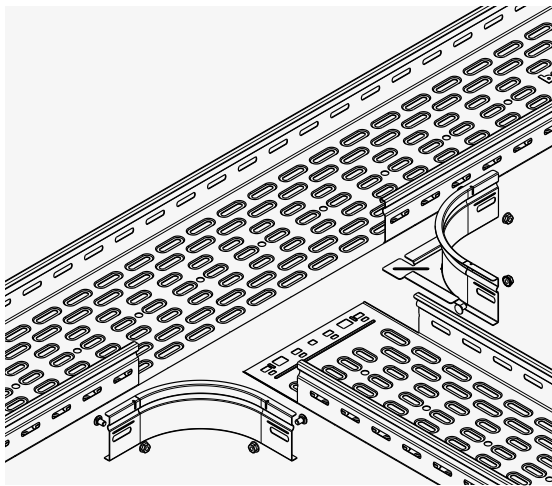

I- INSIDE RISER

▪ H25

Inside riser height 25mm is assembled using 6 screws M6x12 on the bottom. The third screw in the middle is optional up to and included width 300mm. For painted version put the third screw in the middle for all widths to assure electric conductivity. In case of covers, first fix the cover on the fitting before fitting the cover lengths. Optional for width from 400mm to 600mm: use the hole $\varnothing 7\text{mm}$ in the middle of the outer side wall to create an extra suspension for more rigidity.

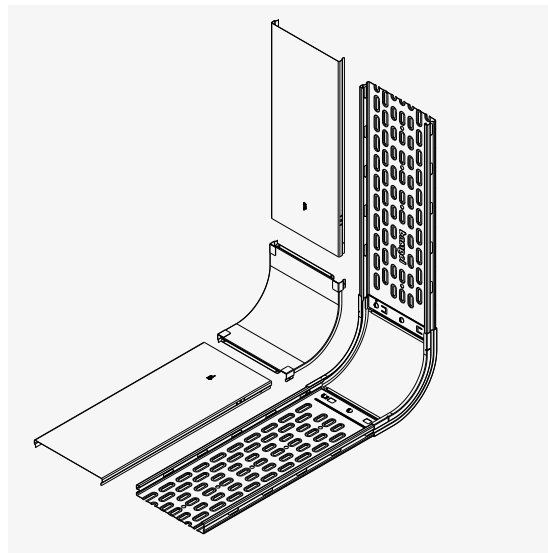
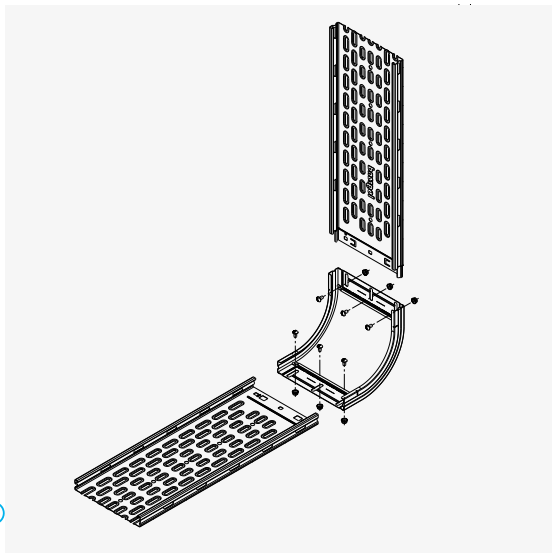

▪ H50-60

Inside riser height 50 and 60mm are assembled using 6 screws M6x12 on the side and on the bottom. The third screw in the middle is optional up to and included width 300mm. For painted version put the third screw in the middle for all widths to assure electric conductivity. In case of covers, first fix the cover on the fitting before fitting the cover lengths. Optional for width from 400mm to 600mm: use the hole $\varnothing 7\text{mm}$ in the middle of the outer side wall to create an extra suspension for more rigidity.

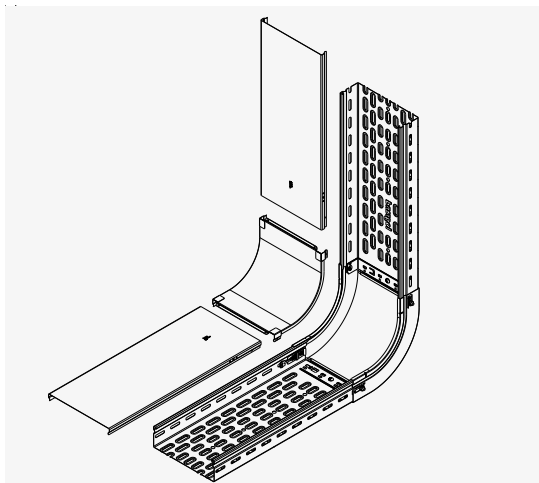
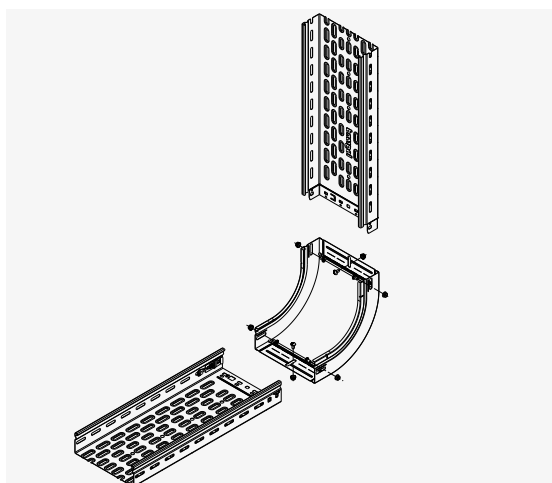

▪ H100

Inside riser height 100mm is assembled using 10 screws M6x12 on the side and on the bottom. The third screw in the middle is optional up to and included width 300mm. For painted version put the third screw in the middle for all widths to assure electric conductivity. In case of covers, first fix the cover on the fitting before fitting the cover lengths. Optional for width from 400mm to 600mm: use the hole $\varnothing 7\text{mm}$ in the middle of the outer side wall to create an extra suspension for more rigidity.

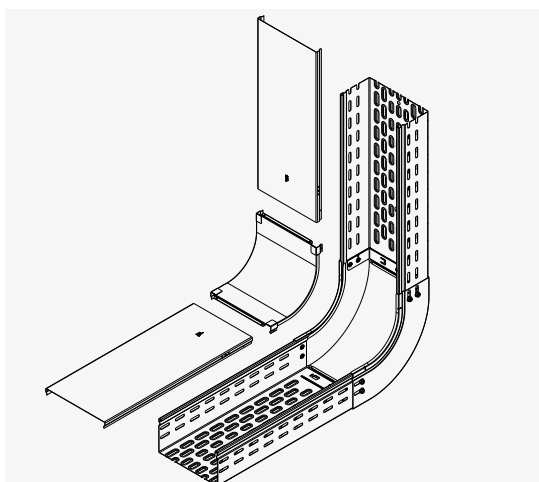
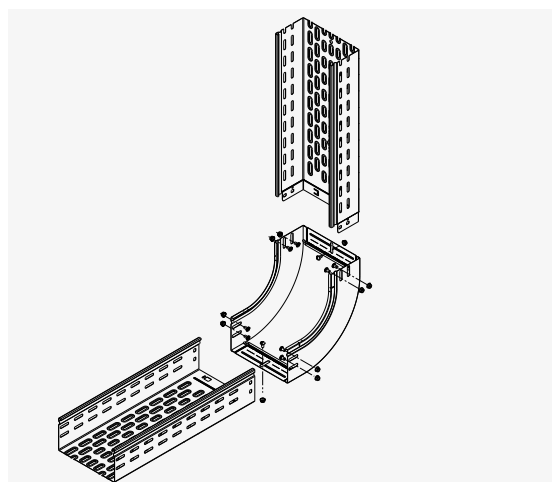

J- OUTSIDE RISER

▪ H25

Outside riser height 25mm is assembled using 6 screws M6x12 on the bottom. The third screw in the middle is optional up to and included width 300mm. For painted version put the third screw in the middle for all widths to assure electric conductivity. In case of covers, first fix the cover on the fitting before fitting the cover lengths. Optional for width from 400mm to 600mm: use the hole $\varnothing 7\text{mm}$ in the middle of the outer side wall to create an extra suspension for more rigidity.

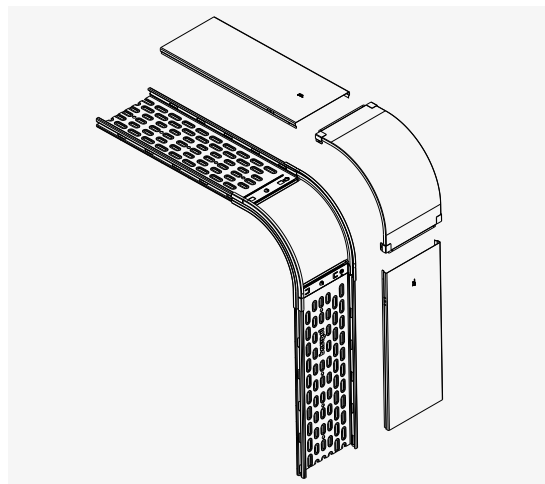
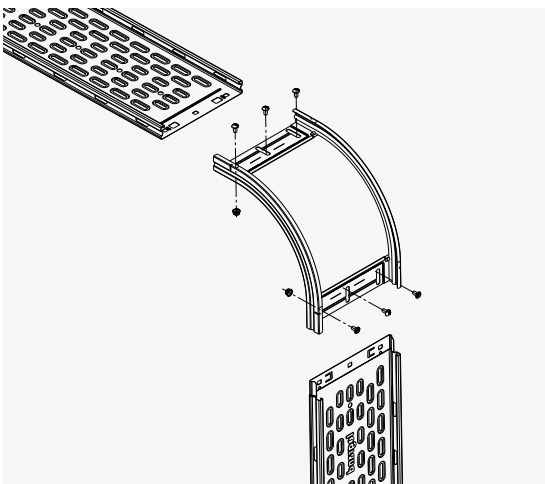

▪ H100

Outside riser height 100mm is assembled using 10 screws M6x12 on the side and on the bottom. The third screw in the middle is optional up to and included width 300mm. For painted version put the third screw in the middle for all widths to assure electric conductivity. In case of covers, first fix the cover on the fitting before fitting the cover lengths. Optional for width from 400mm to 600mm: use the hole $\varnothing 7\text{mm}$ in the middle of the outer side wall to create an extra suspension for more rigidity.

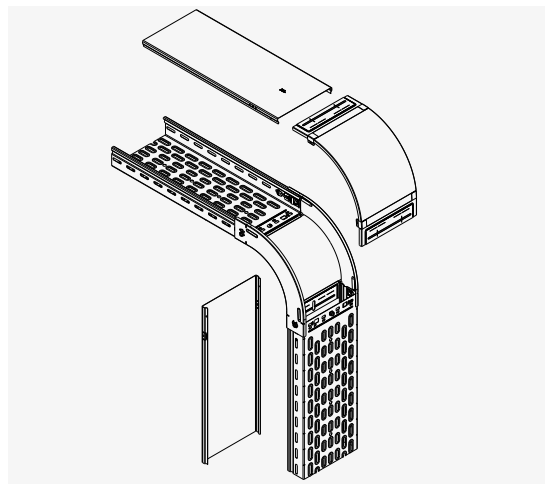
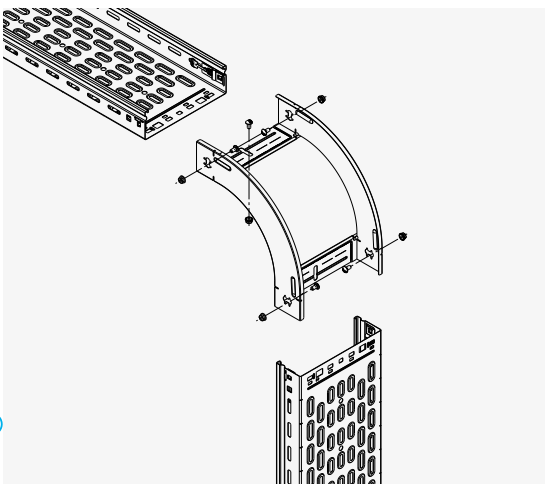

K- OUTSIDE RISER TWIST

▪ H50-60

The Inside / Outside riser is available in height 50 and 60mm. It is assembled using 6 screws M6x12 on the bottom and on the sides. The third screw in the middle is optional up to and included width 300mm. For painted version put the third screw in the middle for all widths to assure electric conductivity. In case of covers, first fix the cover on the fitting before fitting the cover lengths.

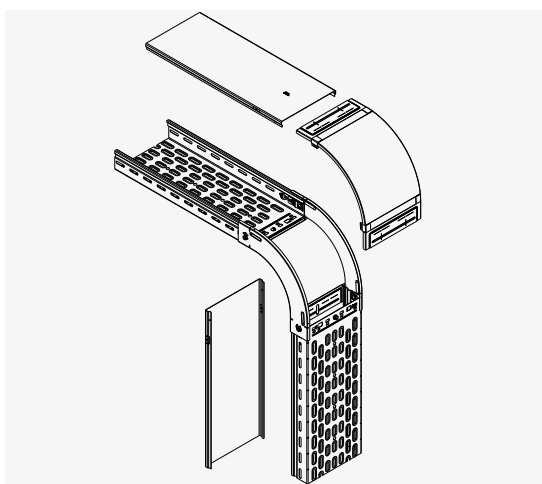
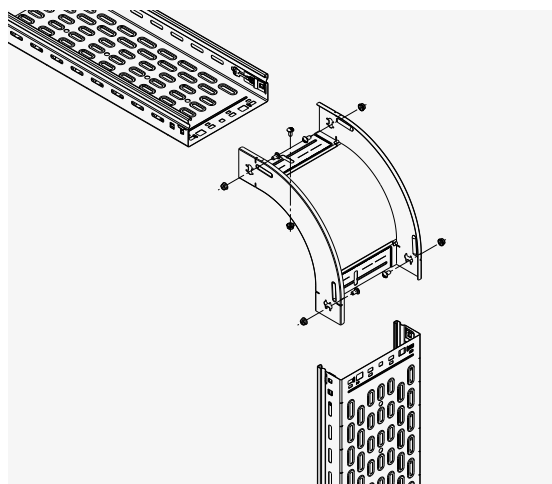

Using this fitting you can also insert the lower cable tray with the bottom upside down as you can see in the pictures below.

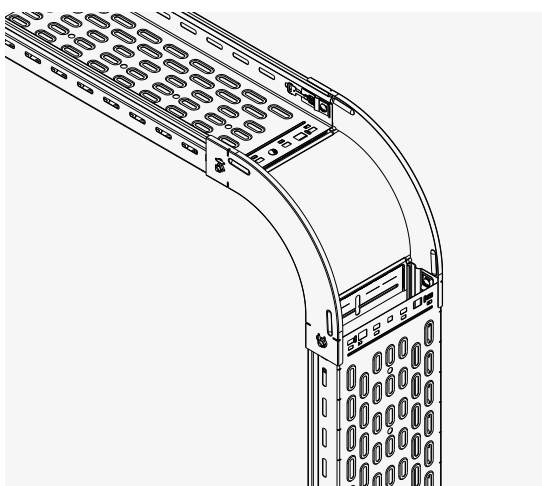
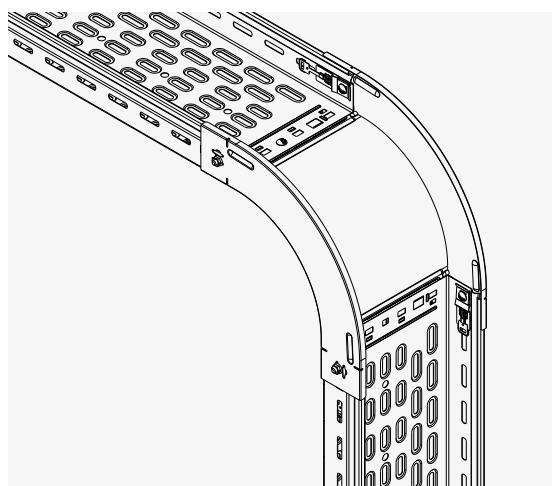

L- VERTICAL TEE

▪ H60

The vertical T is available only in height 60mm. It is assembled using 9 screws M6x12mm. The third screw in the middle is optional up to and included width 300mm. For painted version put the third screw in the middle for all widths to assure electric conductivity. In case of covers, first fix the cover on the fitting before fitting the cover lengths.

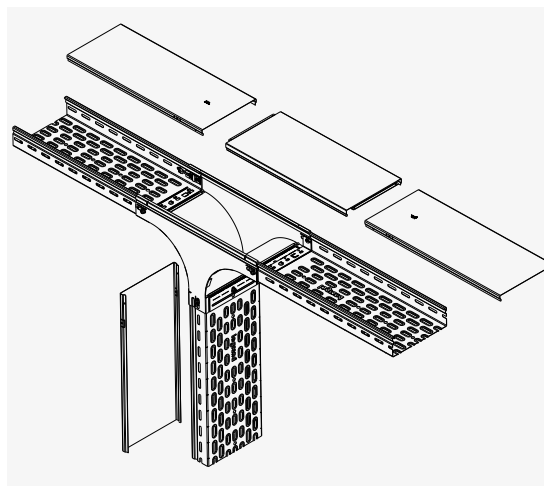
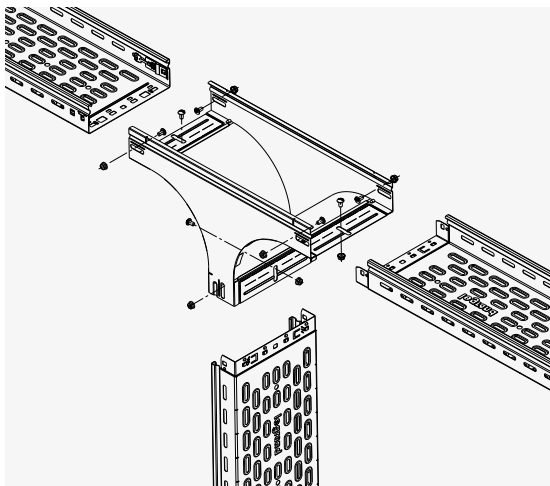

M- VERTICAL BRANCH PIECE

▪ H60

The vertical branch piece with plane variation is available only in height 60mm. It is assembled using 9 screws M6x12mm. The third screw in the middle is optional up to and included width 300mm. For painted version put the third screw in the middle for all widths to assure electric conductivity. In case of covers, first fix the cover on the fitting before fitting the cover lengths.

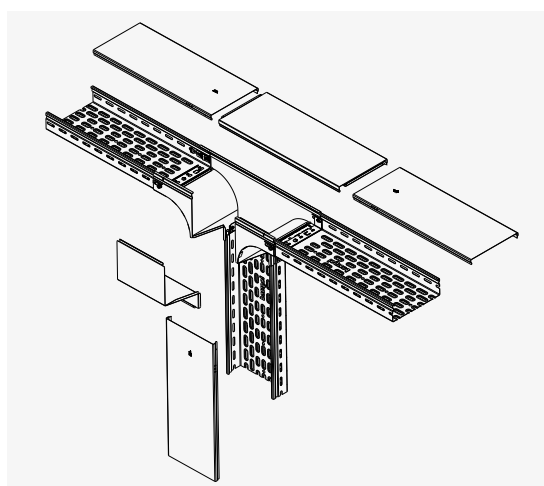
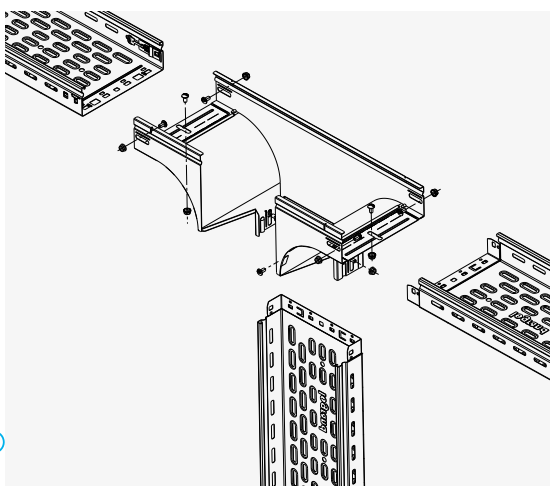

9- FITTING TO FITTING ASSEMBLY

Fittings can be connected directly, without a cable tray, using the EA coupler. Put in contact the fittings and insert two EA coupler, one for each side.

A- H50-60

Slide together the two fittings and add 2pc of EA height 50-60 coupler using 2 screws M6x12 on each coupler.

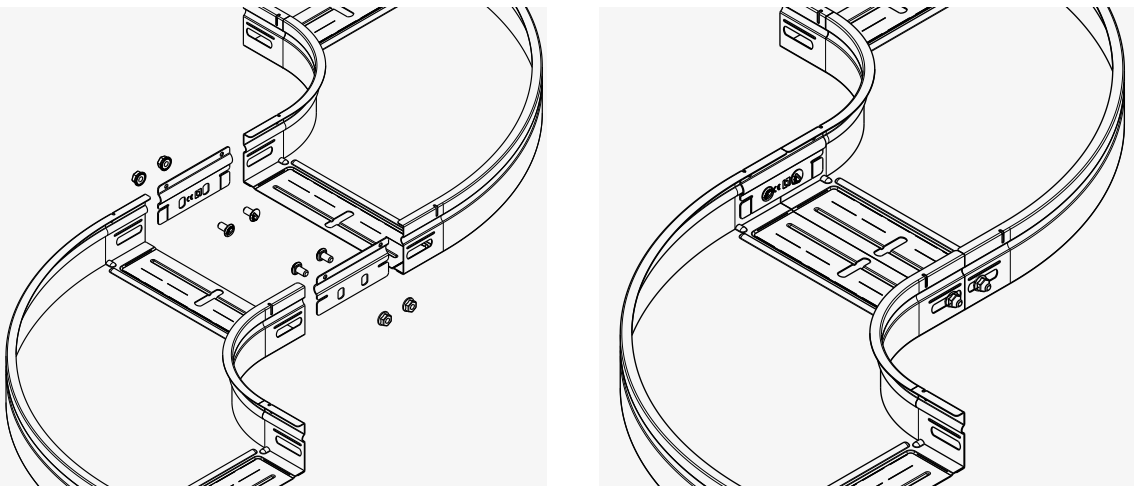

B- H75-100

Slide together the two fittings and add 2pc of EA couplers height 75-100 using 4 screws M6x12 on each coupler.

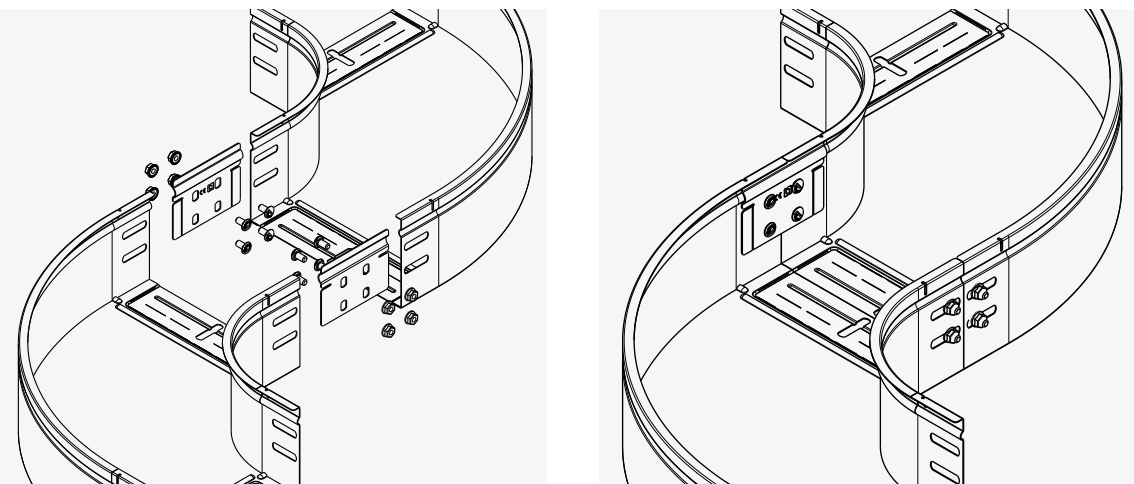

C- ELECTRICAL CONTINUITY FOR PAINTED VERSION

For painted version, to assure electric conductivity between fittings, it is enough the use of the EA coupler.

10- ADJUSTABLE BEND FITTING

Flexible fittings can be screwed together to form other angles as well without extra parts. Flexible bends allow a bend in both horizontal and vertical plane ($\pm 10^\circ$) at the same time. They come in a flat format and the sidewalls are to be bend vertical on site.

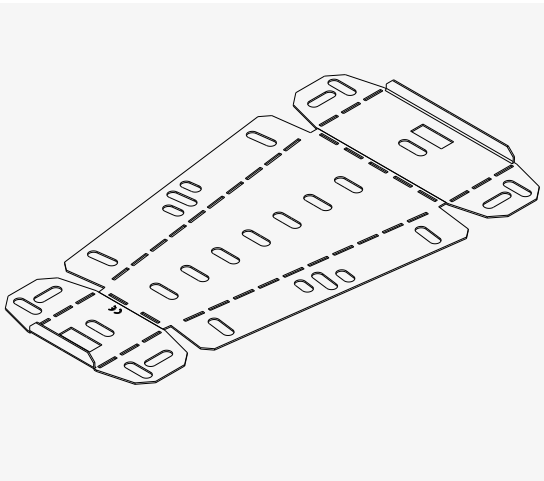

Delivered in flat format

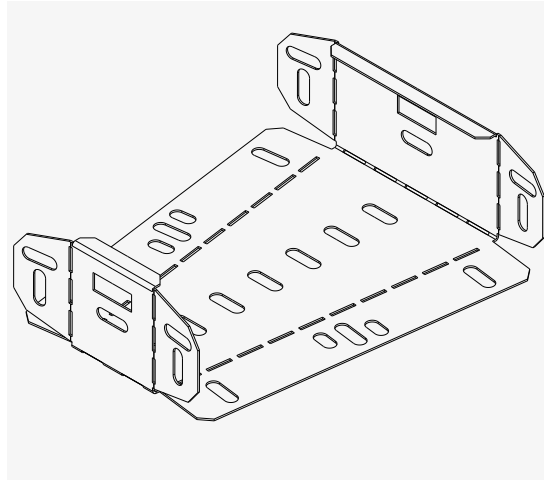

Used with sidewalls bend upward

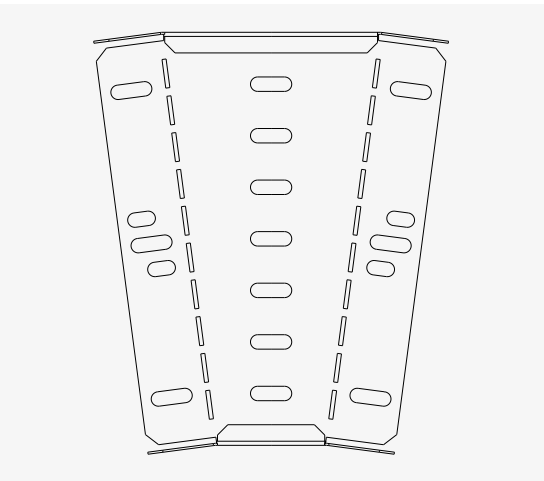

Normal use

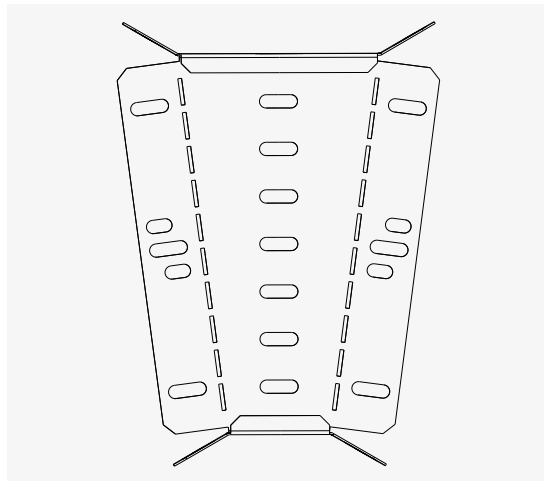

10° inside, outside and up or down extreme use

Also the cover have the same arrangements for inside and outside riser angle range.

A- H60 FLEXIBLE BEND (15° - 30° - 45°)

Flat bend in height 60mm are available in 15°, 30° and 45°. They are assembled using 3 screws M6x12 in the side and bottom. See below an impression of the possible bends horizontal and vertical at the same time.

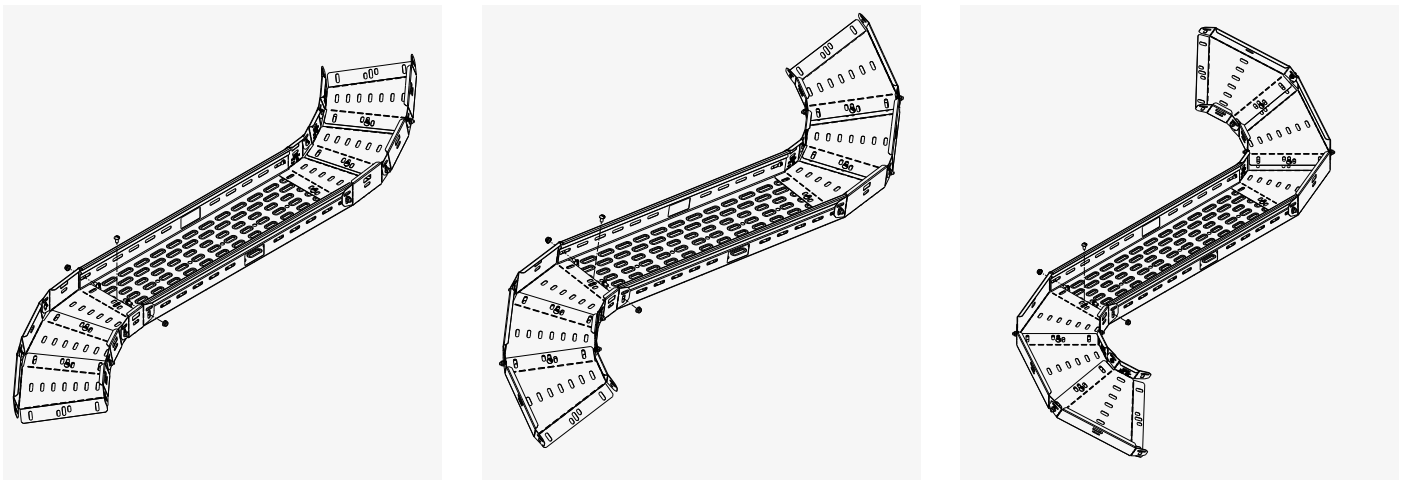

In case of covers, first fix the cover on the fitting before fitting the cover lengths. Covers have been designed to allow the 10° deviation.

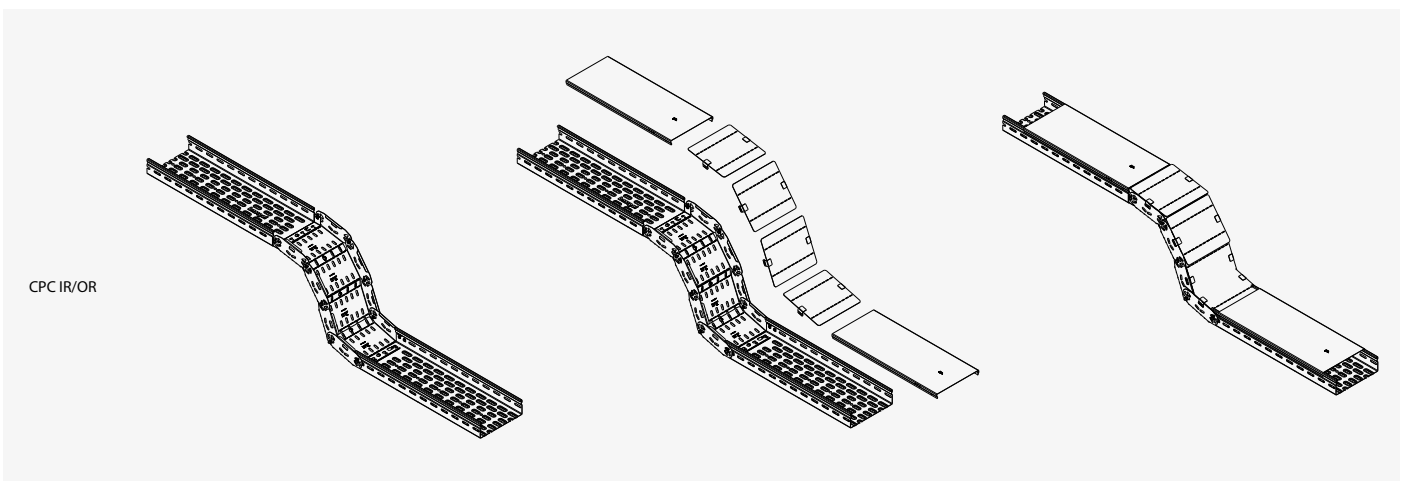

B- H100 FLEXIBLE BEND (15°)

Flat bend in height 100mm are available only in 15°. They are assembled using 5 screws M6x12 in the side and bottom. See below an impression of the possible bends horizontal and vertical at the same time. In case of covers, first fix the cover on the fitting before fitting the cover lengths. Covers have been designed to allow the 10° deviation.

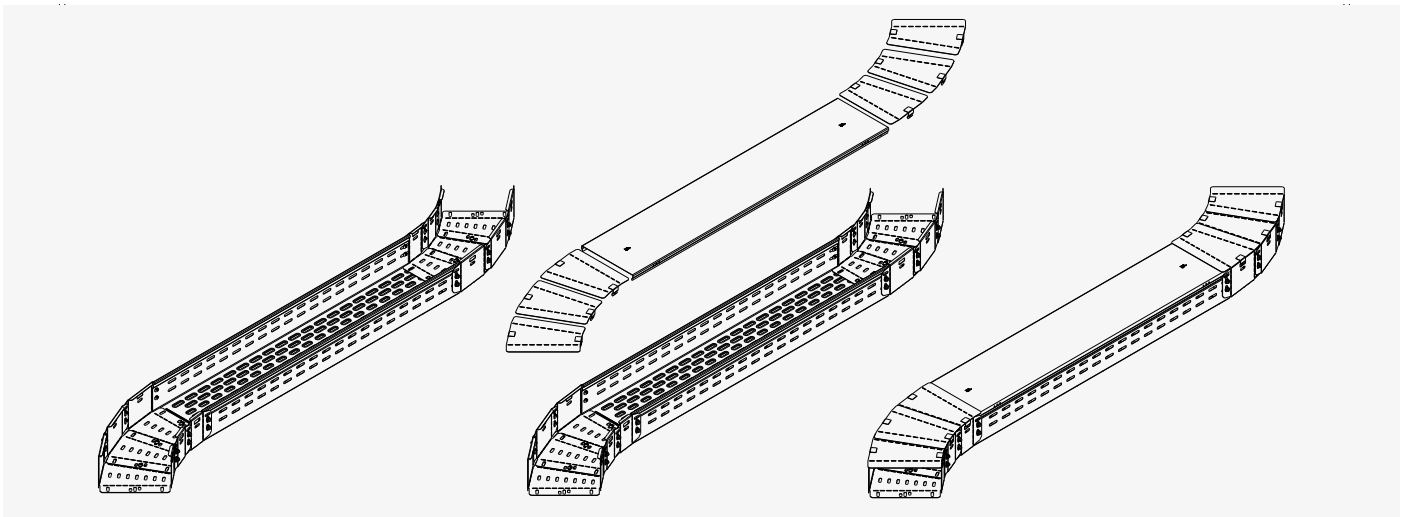

C- H60 INSIDE - OUTSIDE RISER

The Inside - Outside riser height 60mm is assembled to each other, cable trays and other fittings using 3 screws M6x12 in the side and bottom. It forms an angle of max. 45° up or down from the previous part. In case of covers, first fix the cover on the fitting before fitting the cover lengths. Covers have been designed to allow the 45° deviation.

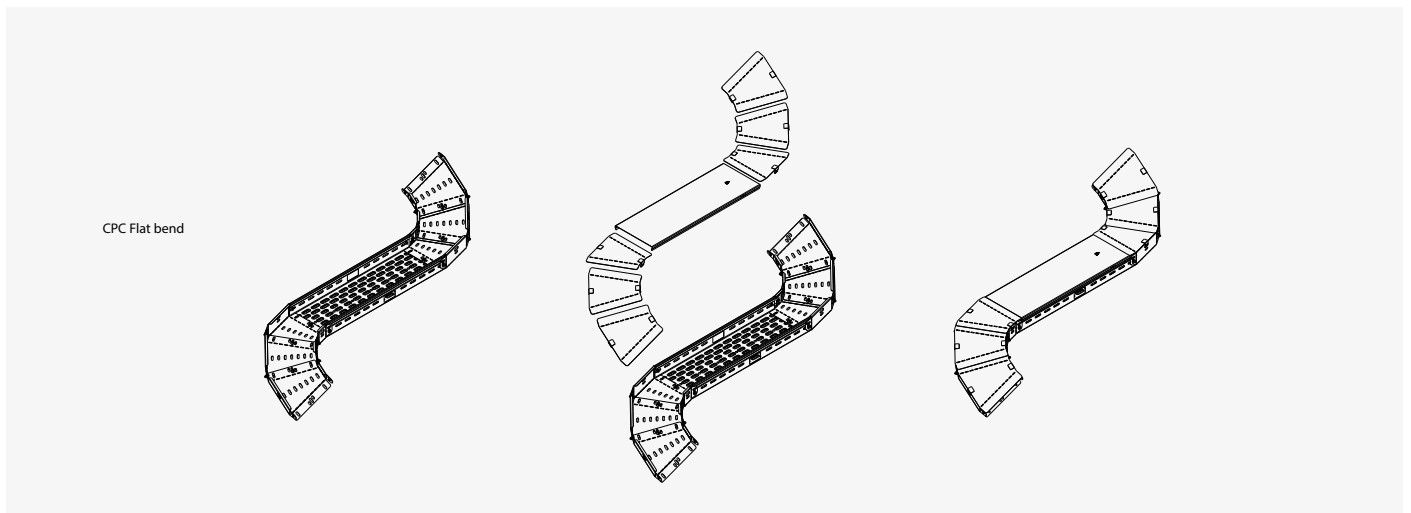

D- H100 INSIDE - OUTSIDE RISER

The Inside - Outside riser height 100mm is assembled to each other, cable trays and other fittings using 5 screws M6x12 in the side and bottom. It forms an angle of max. 45° up or down from the previous part. In case of covers, first fix the cover on the fitting before fitting the cover lengths. Covers have been designed to allow the 45° deviation.

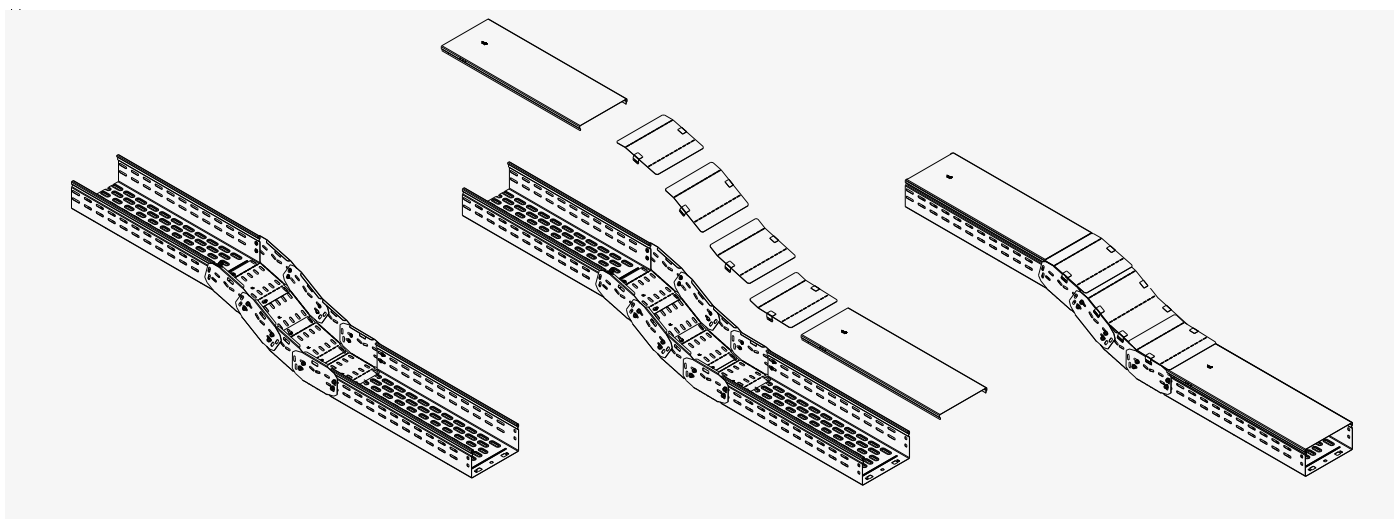

11- VERTICAL COUPLER

This coupler is available in height 50mm, 60mm and 100mm. The vertical coupler is used to connect the side wall when bending cable trays in vertical direction. This allows the installation the change of height or forming an articulated vertical bend. To create a change of height, cut the sides of the cable trays as shown in detail A and detail B.



Please, do not cut the bottom of the cable tray.

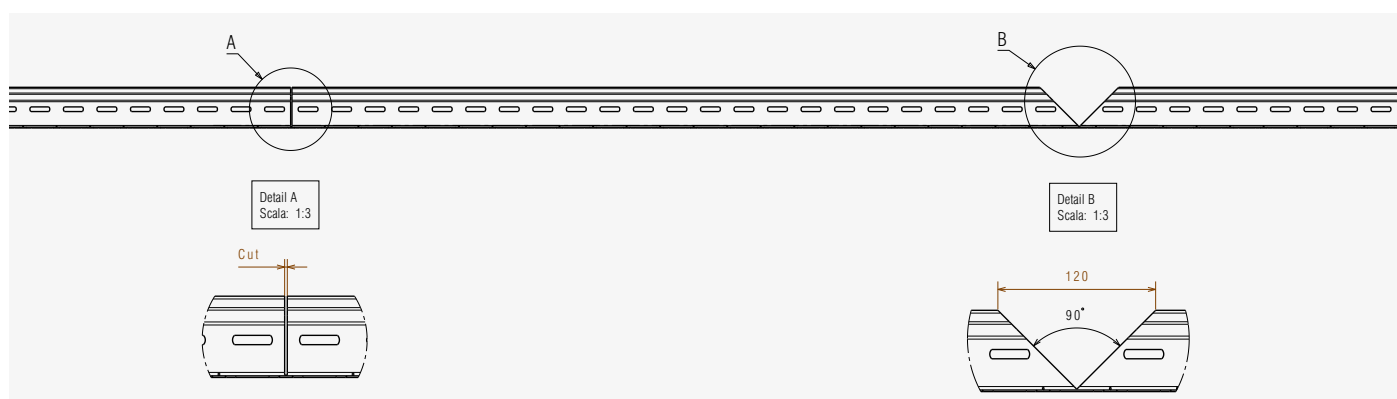

Choose the right angle of inclination for the coupler.

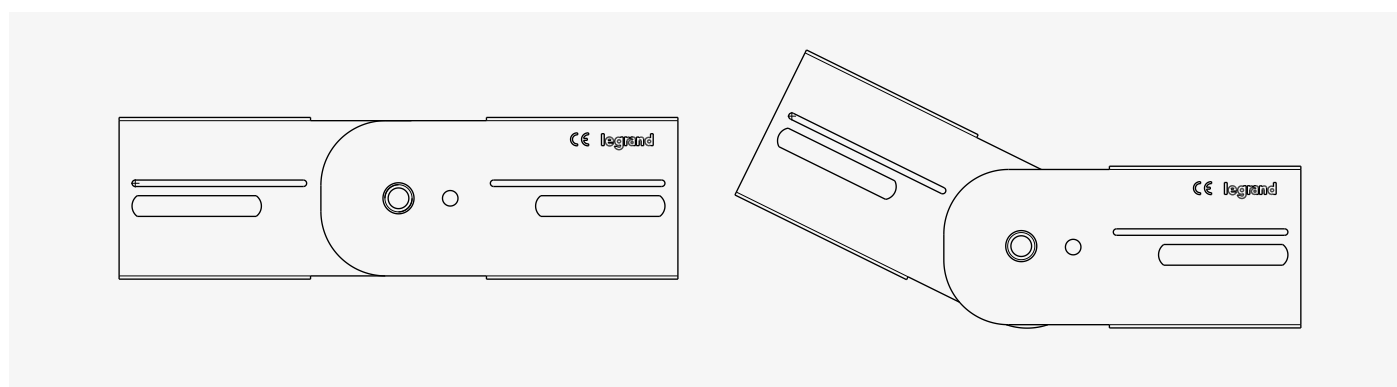

Bend the cable tray at the required angle (between 0 to 45°).

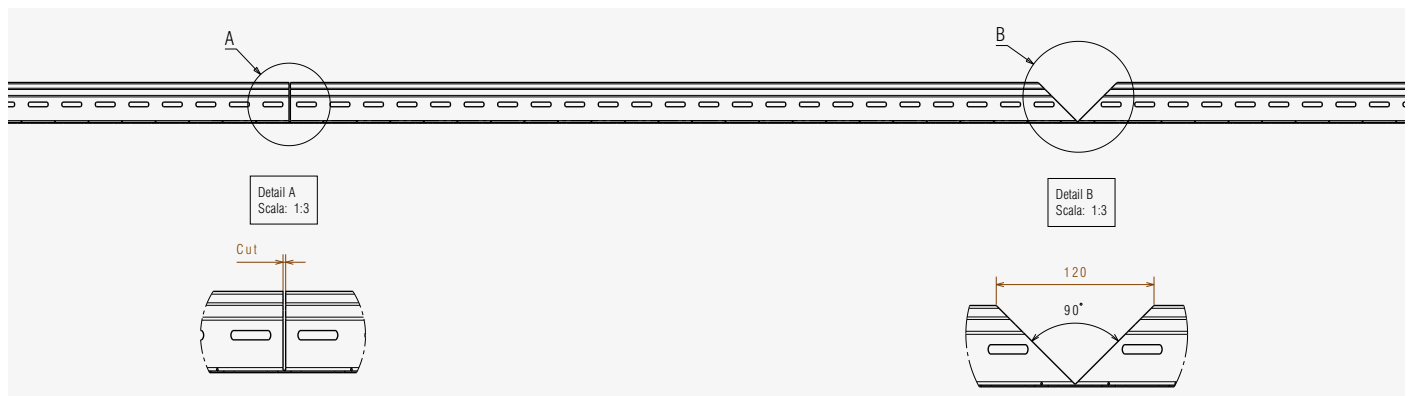

At each bend, fix a vertical coupler to each side wall using 2 screws M6x12 for each coupler height 60mm and 4 screws M6x12 for height 100mm. Images below show installation height 60mm but installation height 100mm works the same.

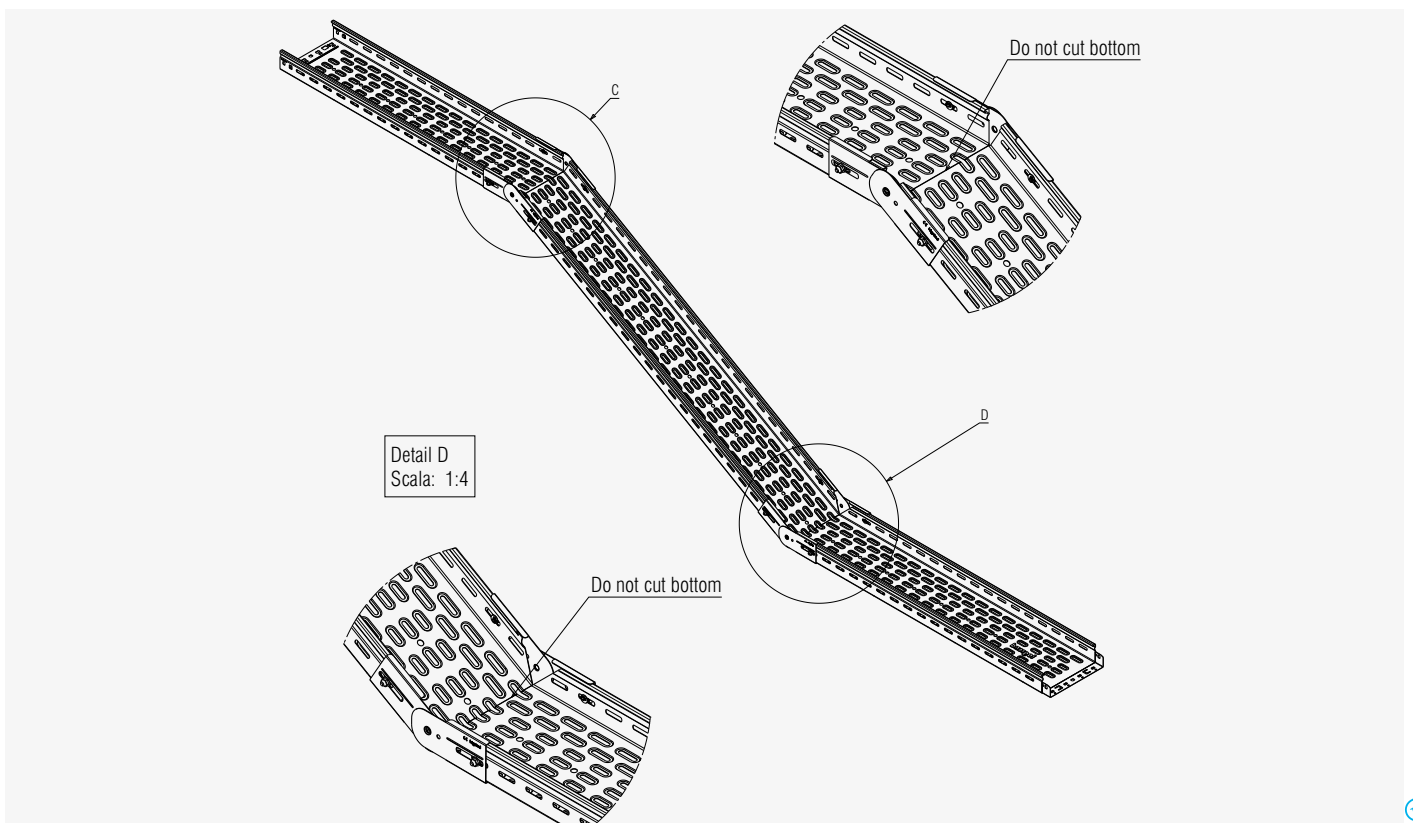

12- EDU COUPLER

The EDU coupler is a multifunctional accessories produced for height 50mm, 60mm and 100mm. Use min. 2 screws M6x12 for height 50 and 60mm, and min. 4 screws for height 100mm. One of the advantages of this coupler is that you can bend or break it (bend several times) by hand.

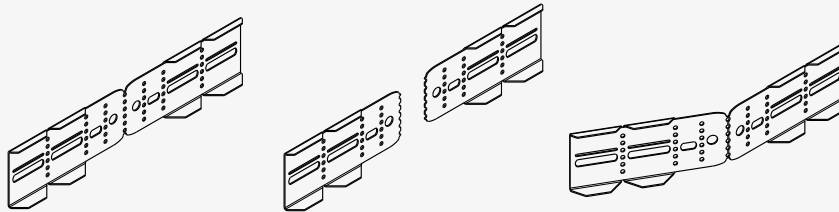

The paragraphs below show the most common installations with the help of this coupler. The examples shown are made using height 60mm cable tray. For height 100mm it works the same way.

Recommendation: while creating installations, keep in mind the minimum bending radius for cables; create articulated bends where necessary.

A- EDU - FLAT BEND (15° - 30° - 45°)

The EDU coupler can be used to create a (double) flat bend.

Start with cutting the side of cable trays at the right dimensions. (See the table to determine the length 'X' depending on the bend required). Second, cut the bottom of the cable tray in the middle of "X", perpendicular to the direction of the cable tray.



Only make a small cut in the horizontal top of the cable tray as shown in detail A. The side wall remains not cut.

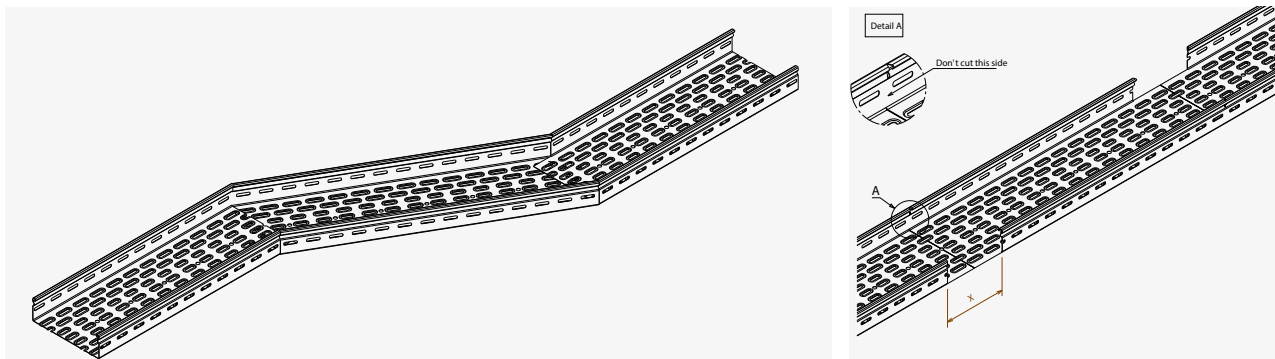

After bending the cable tray, the bottom will overlap (A). If not acceptable, cut a V-shape out of the bottom before bending (B).

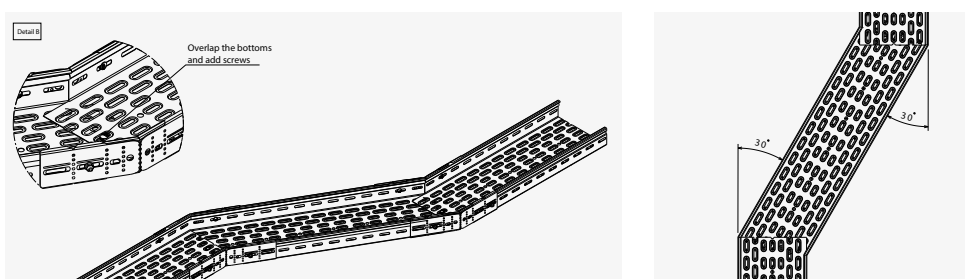

Mount the bend EDU to the cable tray using min. 2 screws M6x12 on each coupler height 60mm. For height 100mm, use min. 4 screws M6x12 per EDU. Place the screws as close as possible to the bend

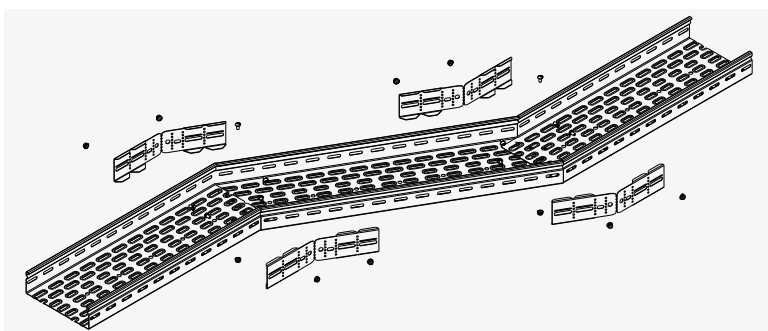

Recommendation: place a screw M6x12 in the middle of the overlapping zone to fixate the bottoms.

B- EDU - FLAT BEND 90°

The EDU coupler can be used to create a flat bend of two cable trays in a 90° angle. Cut the side of cable tray over the same length as the cable tray is wide.



Please, do not cut the bottom of the cable tray.

Mount the bend EDU at the inner and outer side wall. Place the screws as close as possible to the bend. Use 2 screws M6x12 for height 60mm or 4 screws for height 100mm. We recommend to reinforce the overlap of the bottoms using a screws.

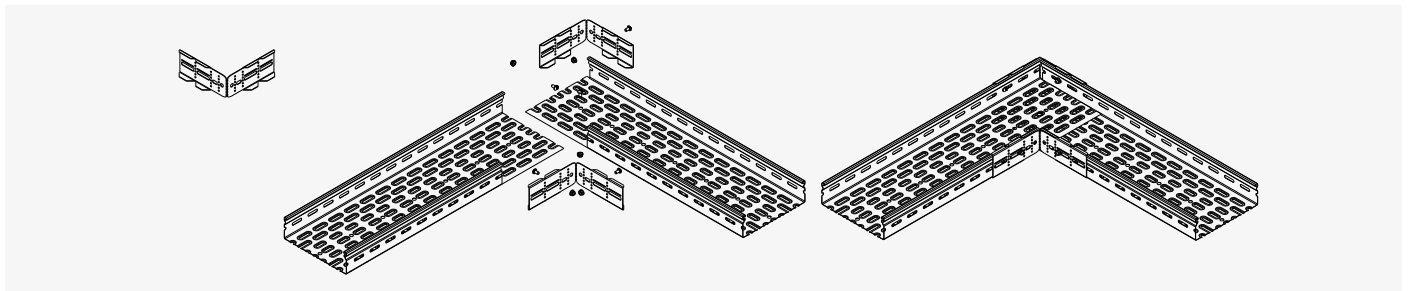

C- EDU - END CAP

The EDU coupler can be used as an end-cap for cable tray up to and included width 200. Find the matching bending line (vertical row of holes $\varnothing 4\text{mm}$) to enclose the width of the cable tray. Mount the EDU using 2 screws M6x12 for height 60mm or 4 screws for height 100mm.

Like end cup
Doesn't need to remove
the automatic coupler.

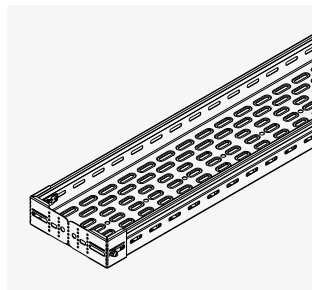
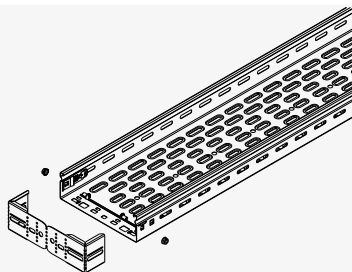

D- EDU - REDUCER

The EDU coupler can be used as a reducer. The maximum width of reduction is 200mm per EDU. Reduction can be done on one or both sides of the cable tray (max. = 2 x 200mm).

Recommendation: Cut the sides of the smaller cable tray on both sides to create an overlap of the bottom. Use 1÷3 screws M6x12 to connect and reinforce the bottoms.

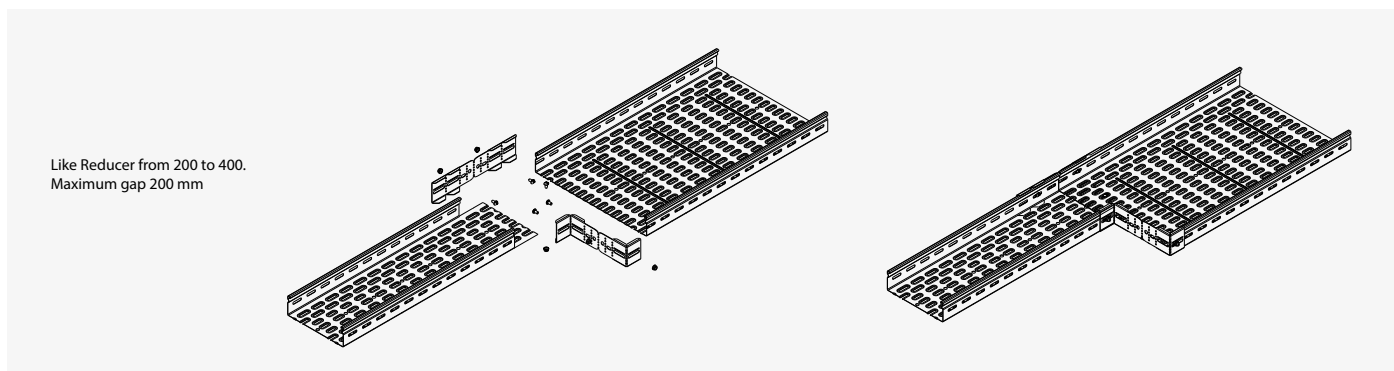

Please note that for larger reductions, see Reducer / End cap (Chapter 13 - Section A).

E- EDU - INSIDE - OUTSIDE RISER BEND

The EDU coupler can be used to connect the side wall when bending cable trays in vertical direction. This allows the installation the change of height or forming a vertical bend in multiple steps like an inside or outside riser. To create a change of height, cut the sides of the cable trays as shown in detail A and detail B:

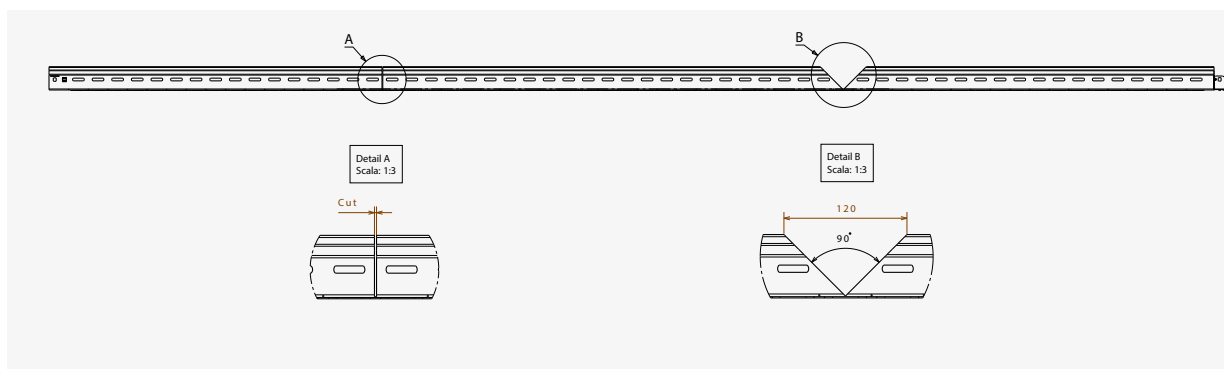

Break the EDU coupler in the middle by manually bending it several times. Connect the two half-part using a screw M6x12 to form a hinge.

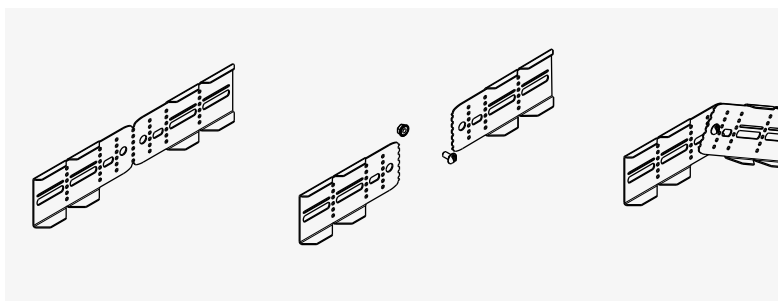

Bend the cable tray at the required angle (between 0 and 45°).

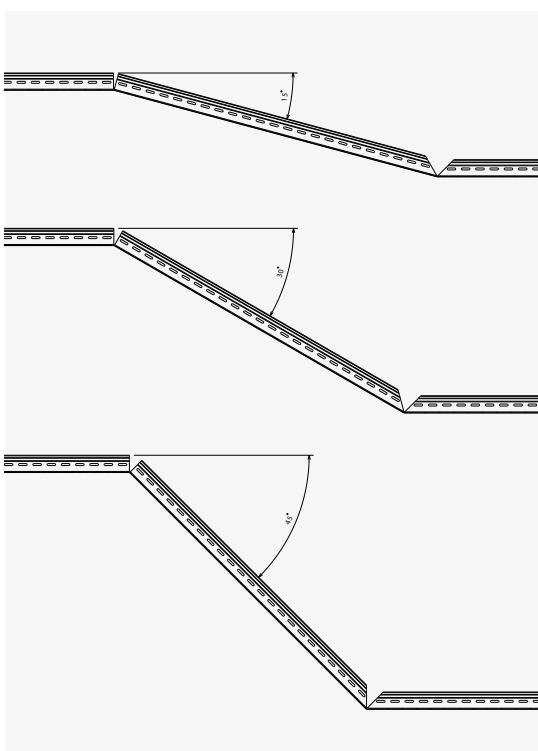

At each bend, fix a modified EDU coupler to each side wall using 2 screws M6x12 for each coupler.

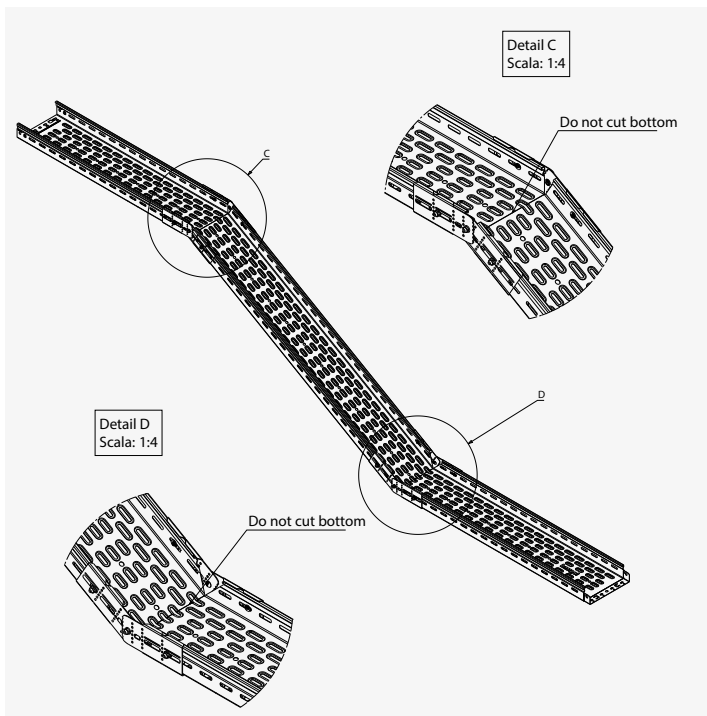

F- EDU – OUTSIDE RISER 90°

The EDU coupler can be used to create an outside riser 90° from the side of the cable tray. Cut the side of the cable tray over the same length as the width of the perpendicular tray.

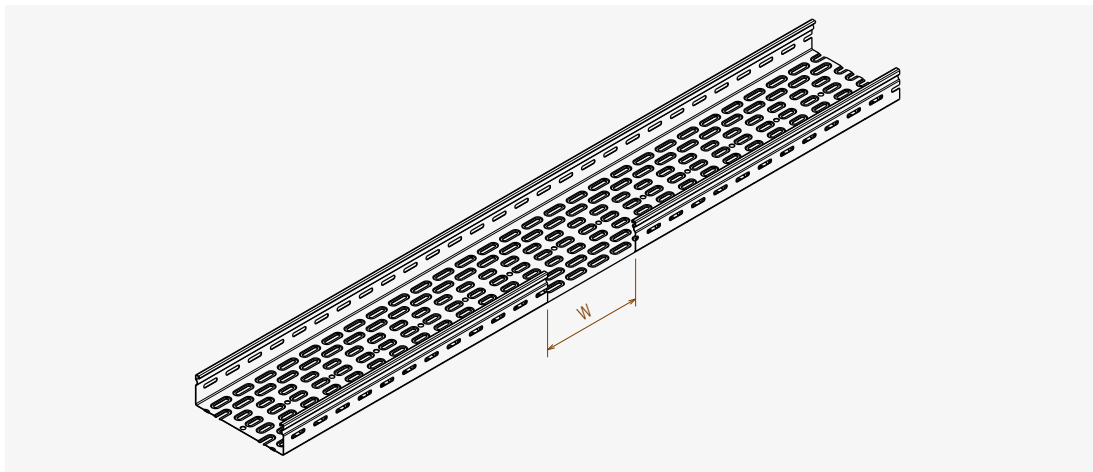

At each bend, fix a modified EDU coupler to each side wall using 2 screws M6x12 for each coupler.

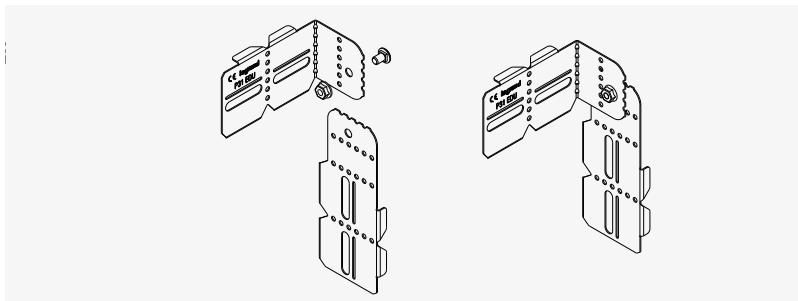

Bend and mount each half of the EDU in the corner and fix them using 2 screws M6x12 for each coupler. Connect the two half-part using a screw M6x12 to form a hinge.

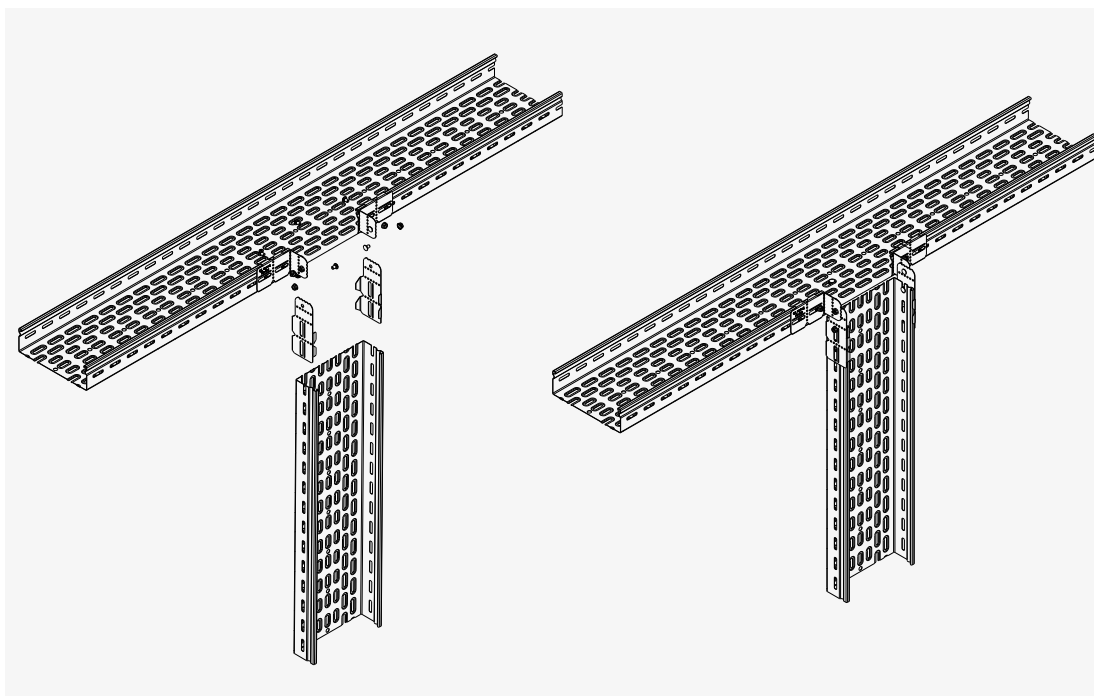

G- EDU - T-BRANCH WITH ANGLE

The EDU coupler can be used to create a lateral junction between two cable trays with an angle $< 90^\circ$. Start with cutting the side of cable trays at the right dimensions. (See the table to determine the lengths 'X' and 'Y' depending on the bend required).



Connect the 2 bottoms for reinforcement:

- Not cut bottom of tray B as to create an overlap and connect both using screw M6x12
- Cut bottom of tray B along the indicated line and use a matching bottomplate to connect both cable trays

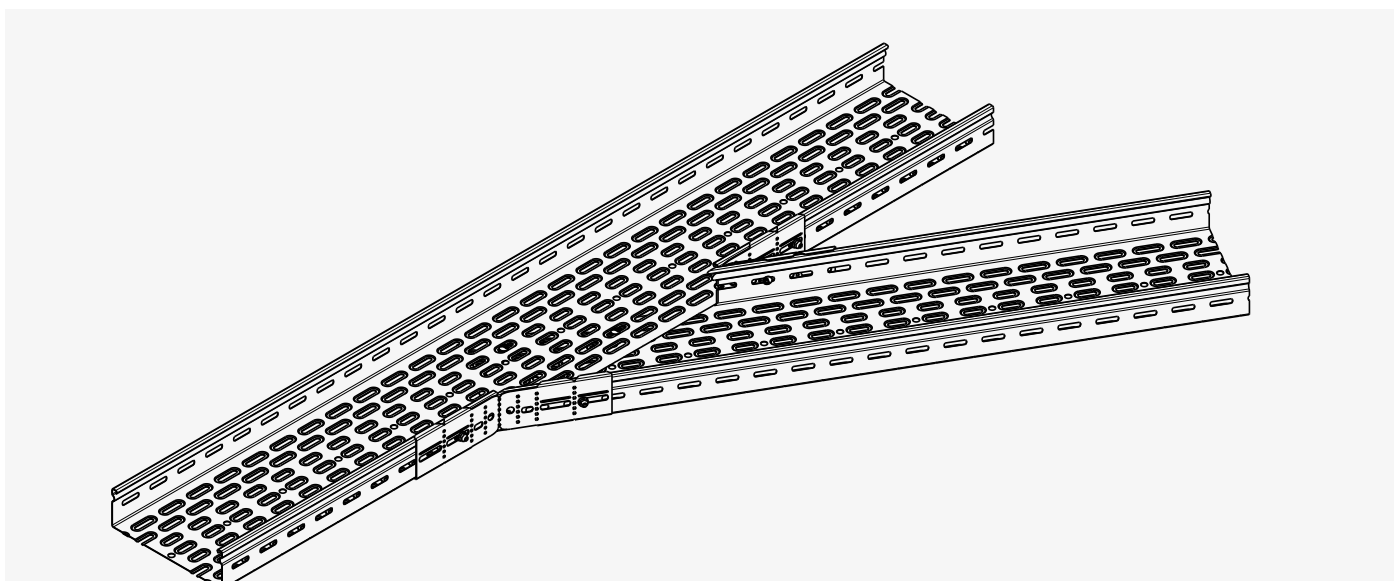

Mount the bend EDU to the cable tray using min. 2 screws M6x12 on each coupler. Place the screws as close as possible to the bend.

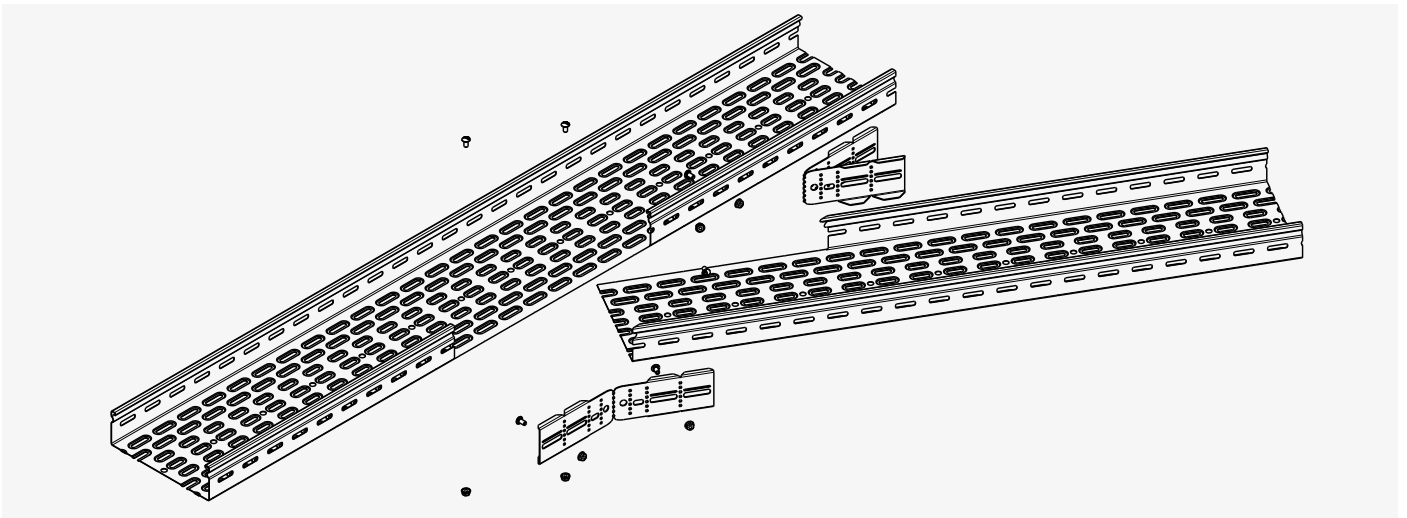

Put two screws M6x12 in the overlap zone to reinforce the bottoms.

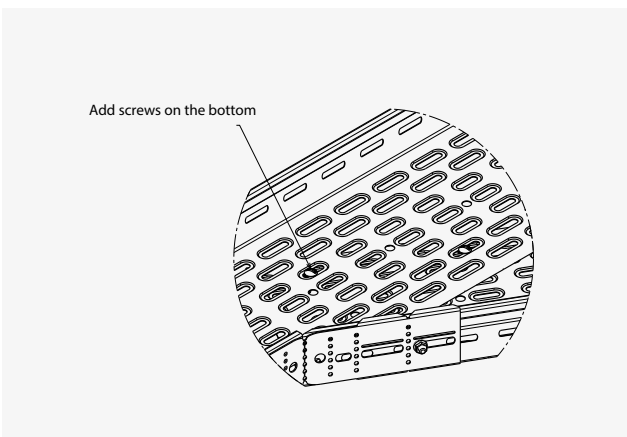

Add screws on the bottom

H- EDU - T-BRANCH

The EDU coupler can be used to create a T-Branch or same level Crossing

Cut the side of the cable tray over the same length as the width of the perpendicular tray. Break the EDU coupler in the middle by manually bending it several times. Slide the 2 cable trays together, bend and mount each half of the EDU in the corner and fix them using 2 screws M6x12 for each half.

Recommendation: cut both sides of the perpendicular cable tray to allow overlap of the bottoms. Use 2÷4 screws M6x12 to connect and reinforce the bottom.

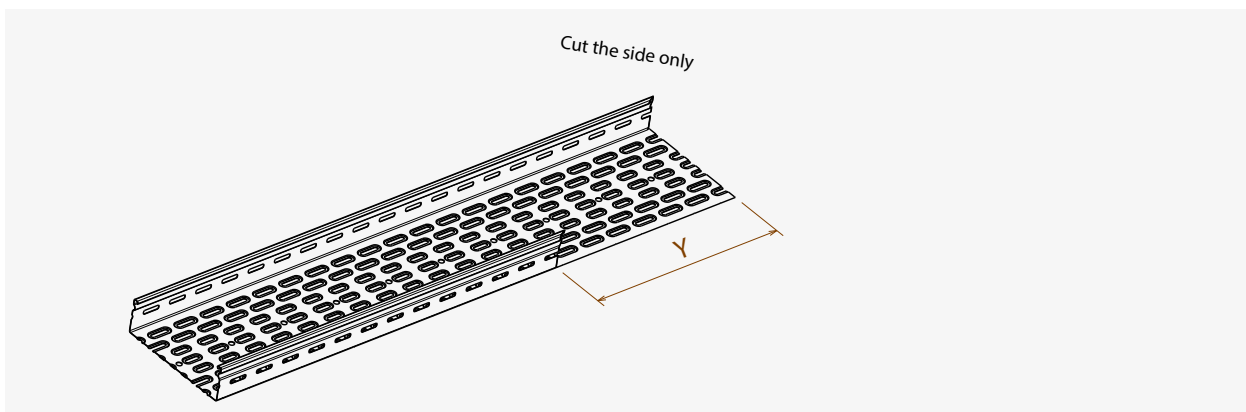

I- EDU FOR COVER

In case the cable tray installation needs to be fitted with covers, used the EDU for cover only available in height 60mm.

If you need to cover cable tray and done some junction you have to use the EDU coupler for cover.

It has the same functions as the standard EDU with the following remarks:

- Use the same number of screws M6x12 for installation,
- EDU for Cover does not cover the full height of the side wall, leaving gaps when used as reduced / end cap,
- When installing, keep in mind the minimum bending radius for cables.

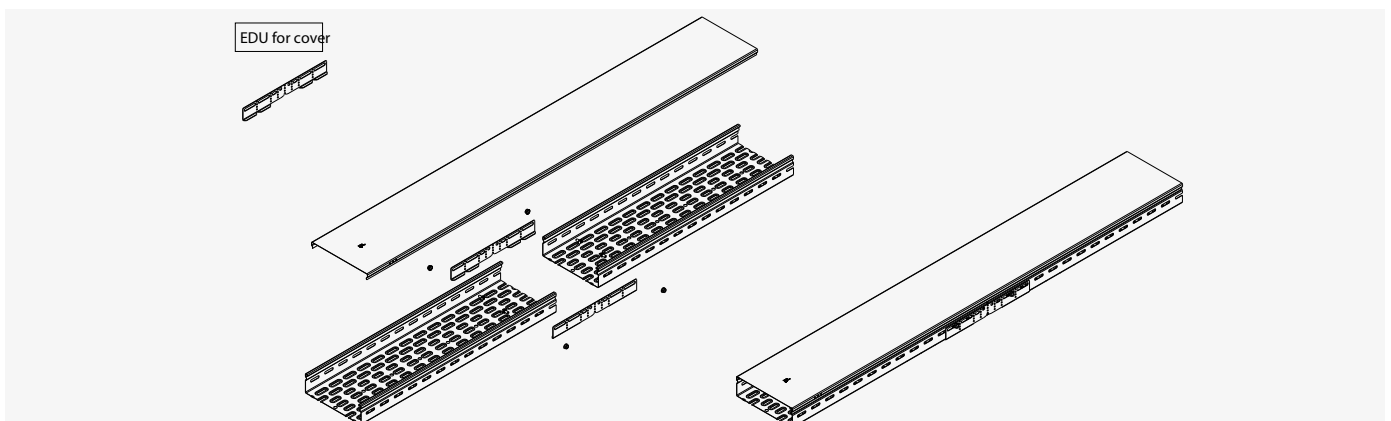

13- REDUCER

Reducers can be bent into various shapes with different dimensions. They can also be broken into parts by manually bending it several times over the same line.

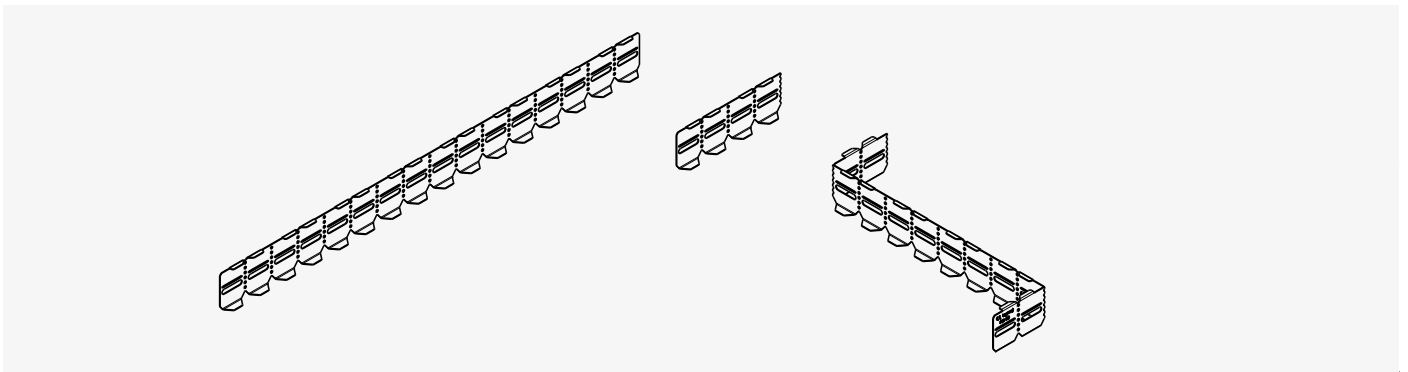

A- H50-60

Breaking a small part of and bending the larger part creates the parts needed to reduce the cable tray width. Mount each part using min. 2 screws M6x12.

Recommendation: Cut the sides of the smaller cable tray on both sides to create an overlap of the bottom. Use 1-3 screws M6x12 to connect and reinforce the bottoms (see Chapter 12 - Section D).

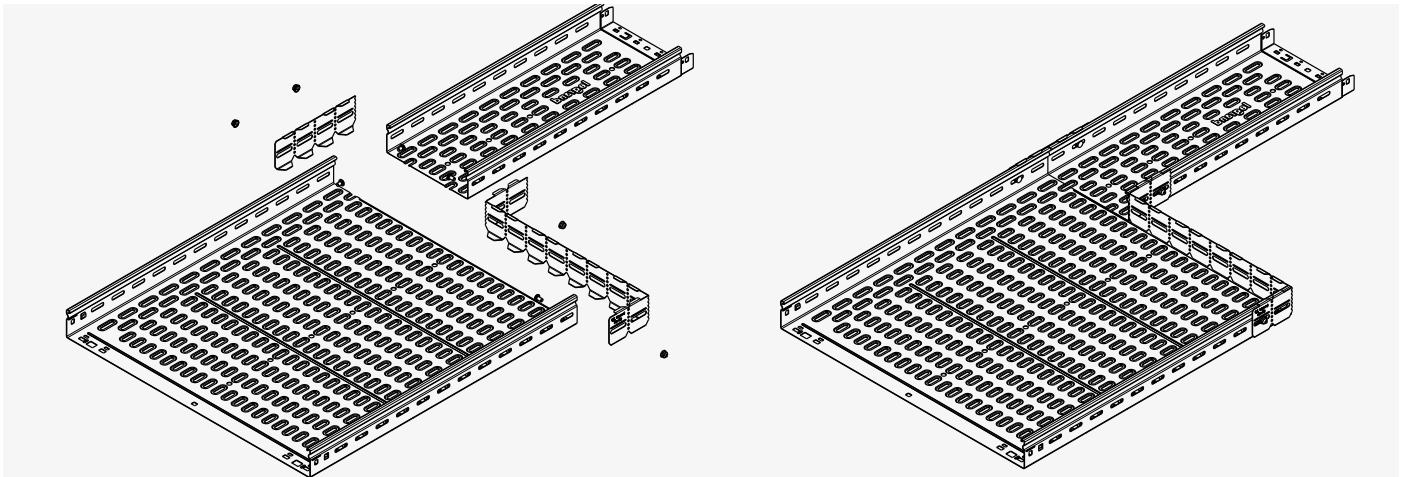

B- H100

Breaking a small part of and bending the larger part creates the parts needed to reduce the cable tray width. Mount each part using min. 4 screws M6x12.

Recommendation: Cut the sides of the smaller cable tray on both sides to create an overlap of the bottom. Use 1÷3 screws M6x12 to connect and reinforce the bottoms (see Chapter 12 - Section D).

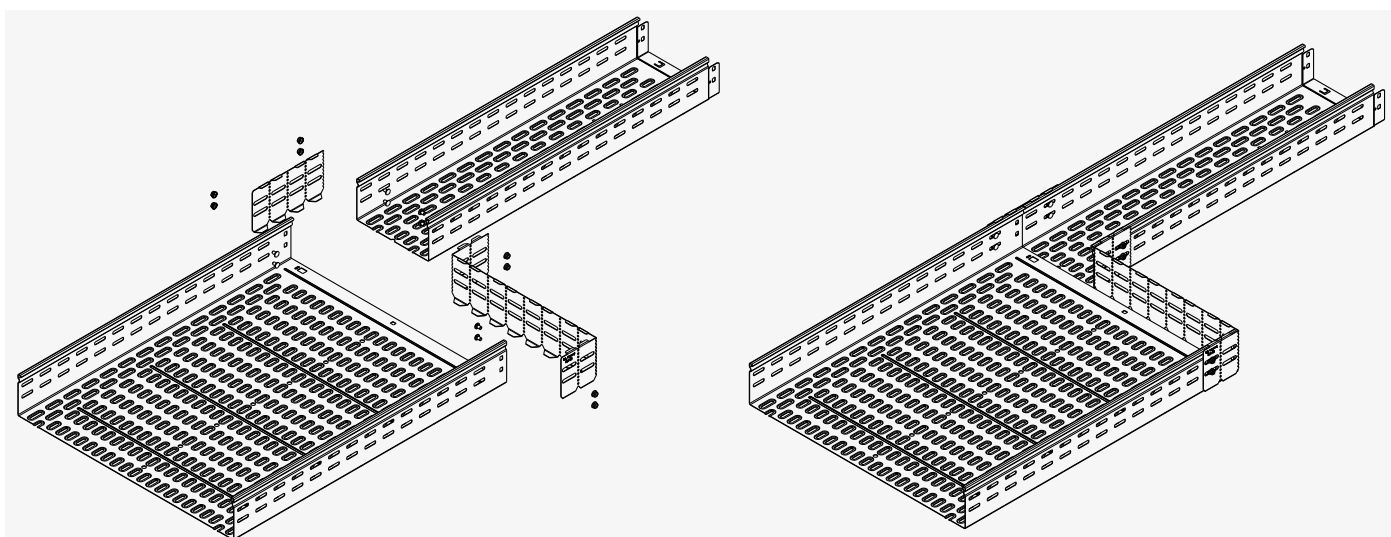

14- DIVIDERS

A- UNIVERSAL DIVIDER FOR LENGTH

The Universal dividers can be used in combination with perforated Male-Female (auto) cable trays: for application in blind cable trays, drill holes $\varnothing 7\text{mm}$ and use screws M6x12: min. 2 screws per piece of divider and max. 600mm apart over longer distances.

Recommendation: for Male-Female (auto) cable trays, keep the connections of the divider at the same location as the connections of the cable trays to ensure a smooth fitting over the tray connection.

Please note to connect length of dividers and for cable protection at the end of the divider, see End Cap (Chapter 14 - Section D).

▪ H25

Mount the divider using min. 5 screws M6x12 evenly divided over the 3m length.

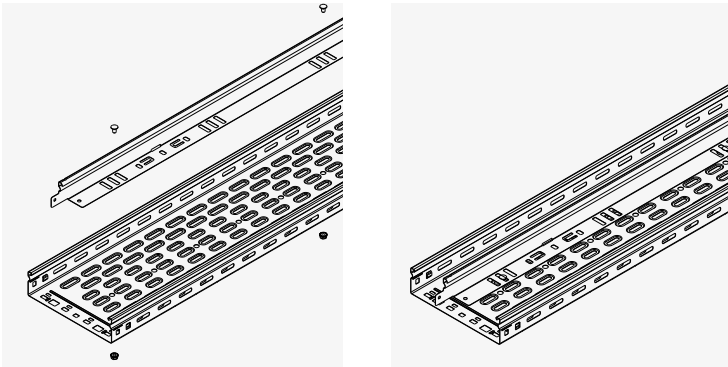

▪ H50

Mount the divider using min. 5 screws M6x12 evenly divided over the 3m length.

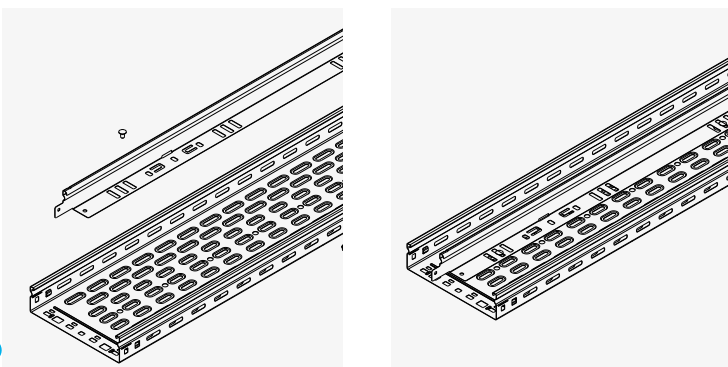

▪ H100

Mount the divider using min. 5 screws M6x12 evenly divided over the 2 or 3m length.

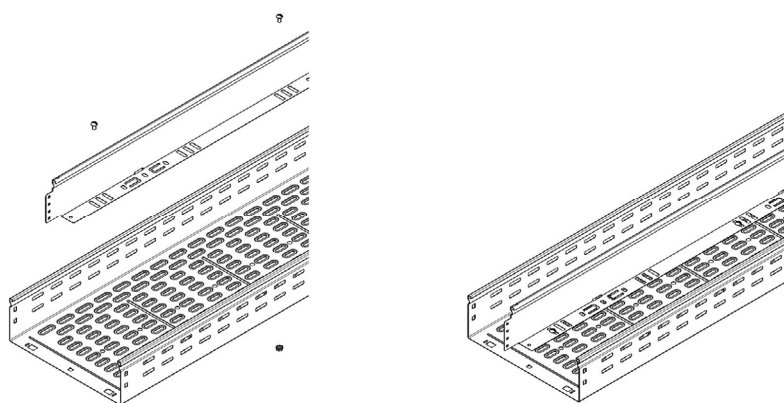

B- AUTOMATIC DIVIDER FOR LENGTH

The Automatic divider is available in height 60mm and can be used in combination with all types of perforated cable trays: Male-Female auto, Male-Female, Symmetrical and Heavy Duty. With the MF (auto) cable trays, the dividers will overlap at the connection of the trays.

Recommendation: for Male-Female (auto) cable trays, keep the connections of the divider at the same location as the connections of the cable trays to ensure a smooth fitting over the tray connection. Screws can be inserted after installation for extra reinforcement.

Please note to connect length of dividers and for cable protection at the end of the divider, see End Cap (Chapter 14 - Section D).

▪ H60

No screws are needed for the installation of the Automatic divider. Line up the teeth of divider with the perforation in the bottom of cable trays. Push and rotate the divider until it makes a “click” in the perforation.

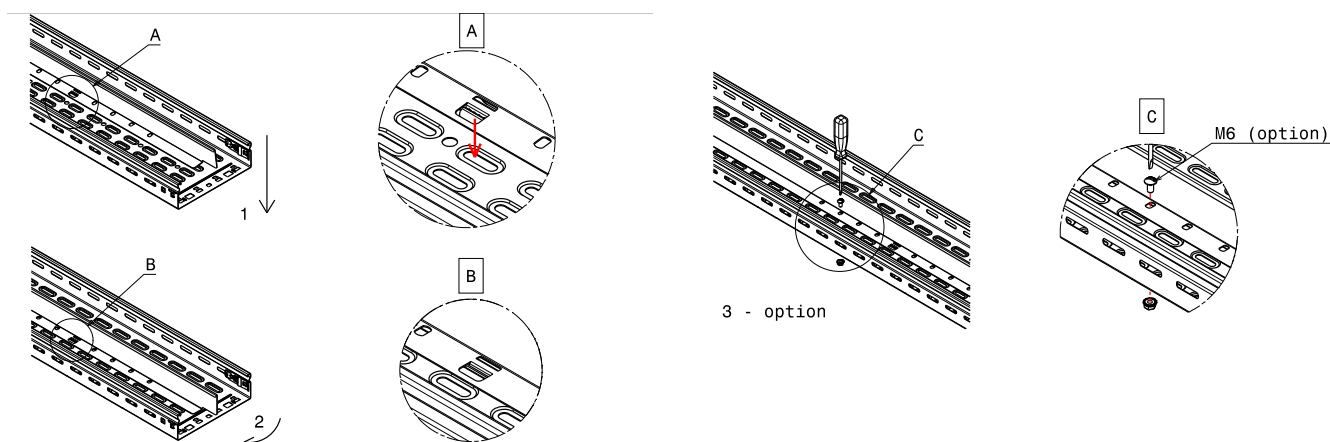

C- UNIVERSAL DIVIDERS FOR FITTINGS

The Universal dividers can be used in combination with all flat fittings. For application in blind bottom, drill holes $\varnothing 7\text{mm}$ and use screws M6x12.

Divider for fittings can be bend into various shapes with different dimensions. They can also be broken into parts by manually bending it several times over the same line. It is recommended to cut the dividers along the line in the middle of the squared holes to permit the application of the divider's protection end-cap (see Chapter 14 - Section D).

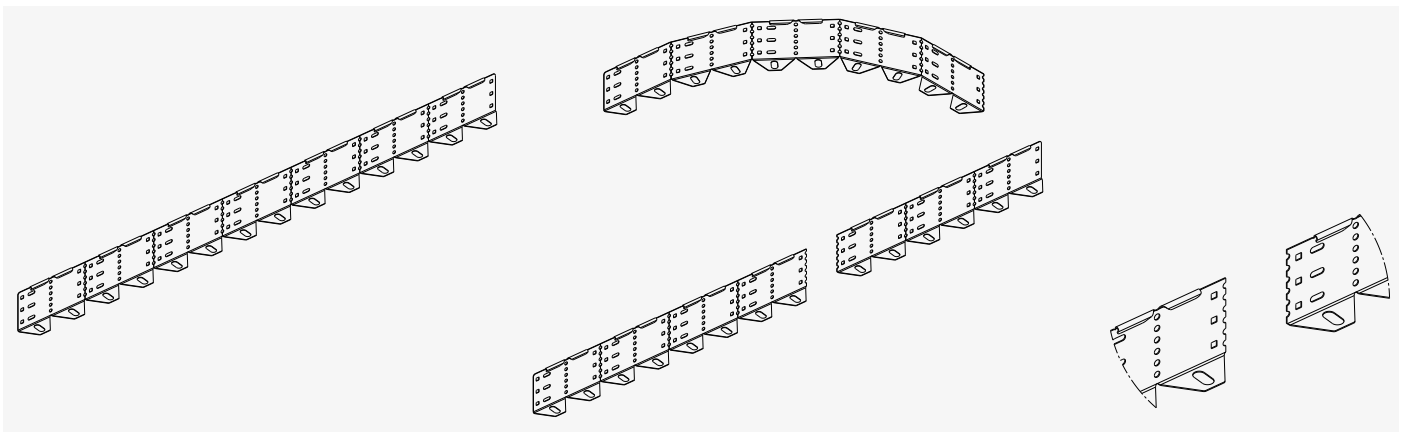

Universal divider for fittings is available in height 50mm, 60mm, 75mm and 100mm. Mount the divider using min. 2 screws M6x12.

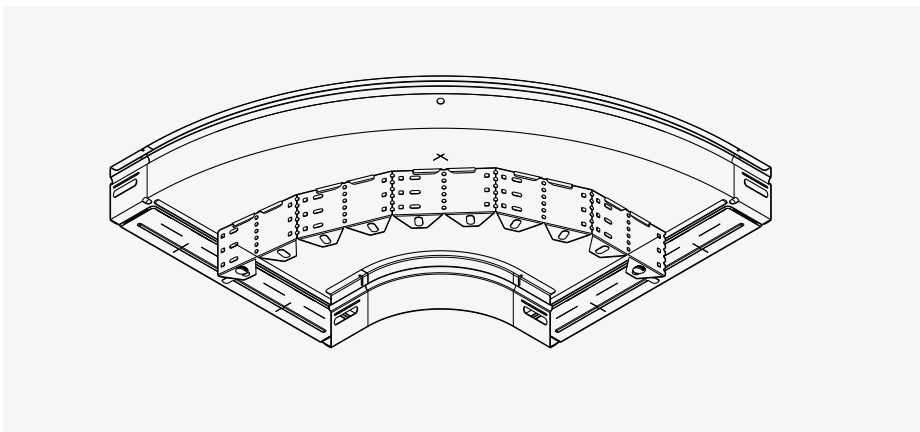

D- END-CAP DIVIDER'S PROTECTION

The End-Cap divider's protection is a yellow plastic part that has two main functions:

- 1) Protect the cables from the beginning and end of the divider when pulling them along these edges,
- 2) Connect dividers to keep them in line with the lengths of cable tray

The End Cap can be used on dividers height 60mm and height 100mm. To adjust it to the actual height of the installation, it can manually be broken into pieces along the grooves. It will "click" in the perforation at the end of the divider.

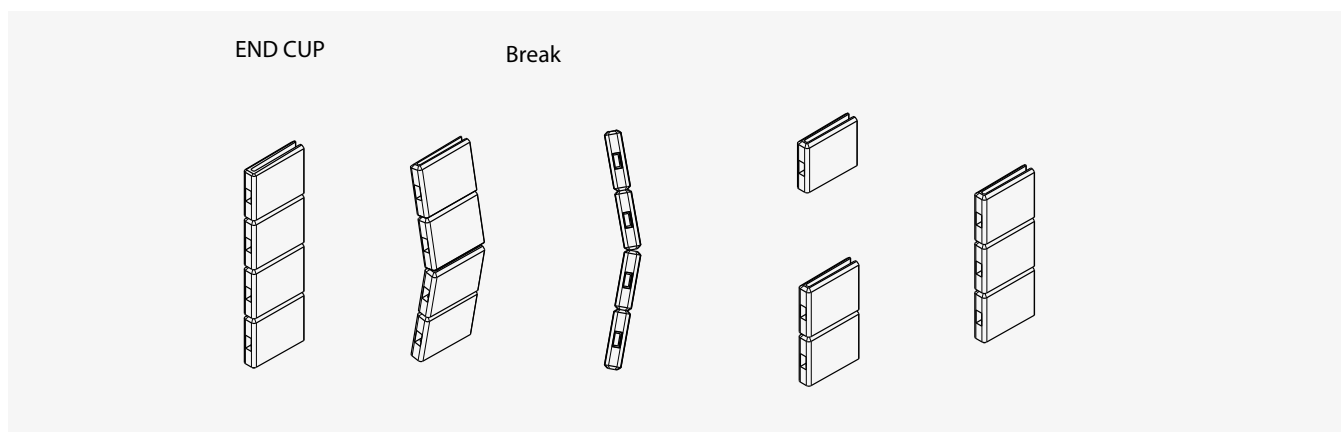

Standard shape

Manually breaking in the middle

Different possibilities of 1, 2 or 3 sections

▪ Application on divider for length

▪ H50

Use a part of 1 section of the End-Cap and push it on the end of the divider until it "clicks".

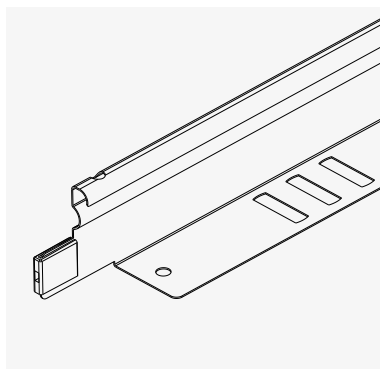
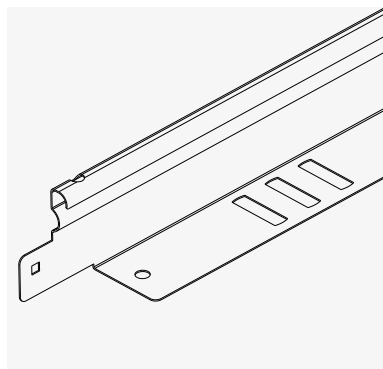

- **H60**

Use a part of 2 section of the End-Cap and push it on the end of the divider until it "clicks!"

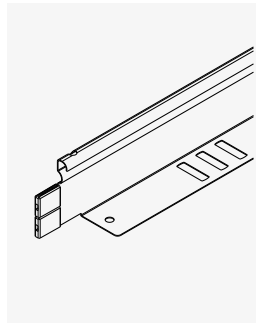
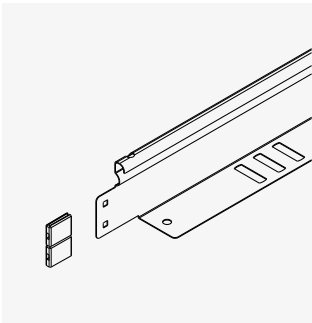

- **H60 automatic**

Use a part of 3 section of the End-Cap and push it on the end of the divider until it "clicks!"

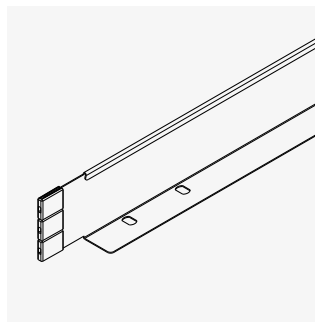
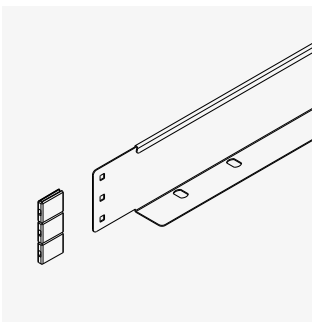

- **H100**

Use the standard End-Cap and push it on the end of the divider until it "clicks!"

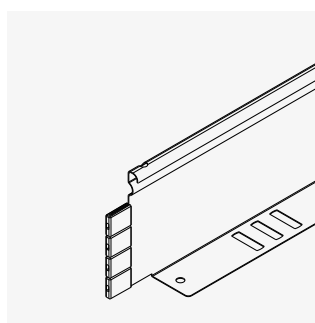
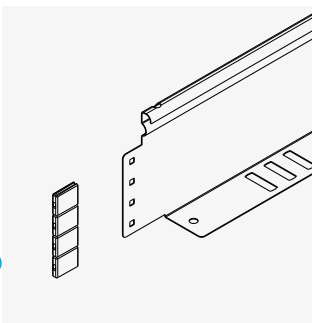

▪ Divider length assembling

Use a part of 2 sections of the End-Cap and push it on the end of the divider until it "clicks". Put one divider in front of another one and push the End-Cap divider uniting.

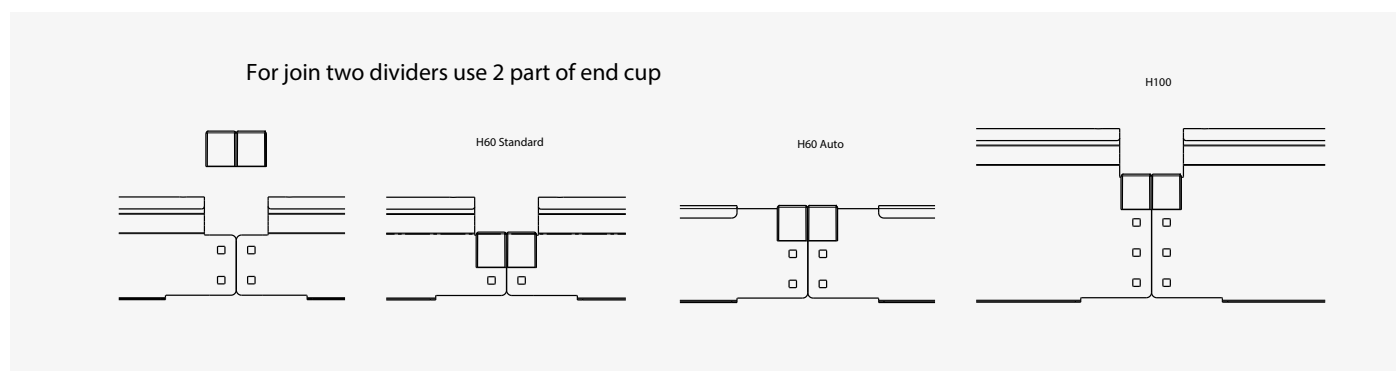

A piece of 2 section of the End-Cap can be used for all heights.

▪ Application on divider for fittings

▪ H50

Use a part of 2 section of the End-Cap and push it on the end of the divider until it "clicks".

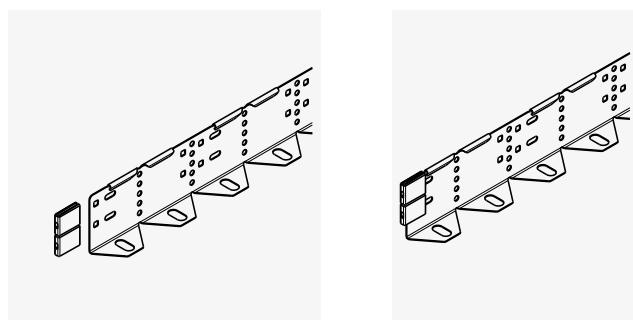

▪ **H60**

Use a part of 3 section of the End-Cap and push it on the end of the divider until it "clicks!"

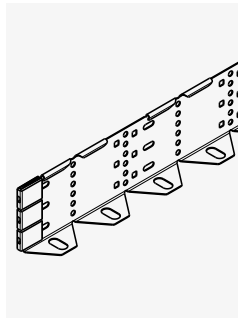
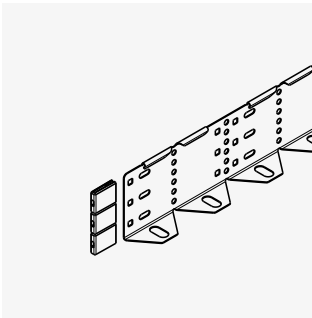

▪ **H75**

Use the standard End-Cap and push it on the end of the divider until it "clicks!"

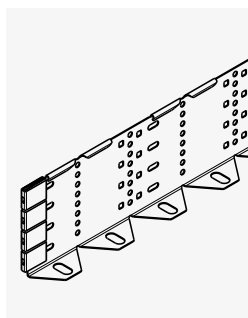
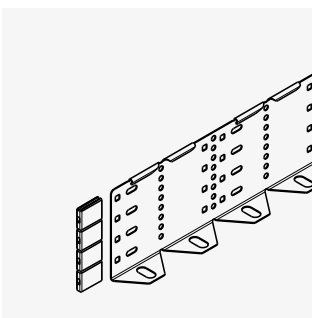

▪ **H100**

Use the standard End-Cap plus 1 section and push it on the end of the divider until it "clicks!"

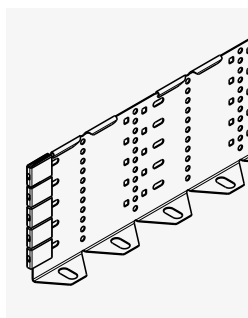
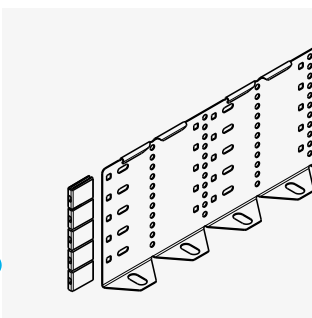

15- END-CAP

A- H25

The End-Cap in height 25 is assembled using 2 screws M6x12 on the bottom of the cable tray.

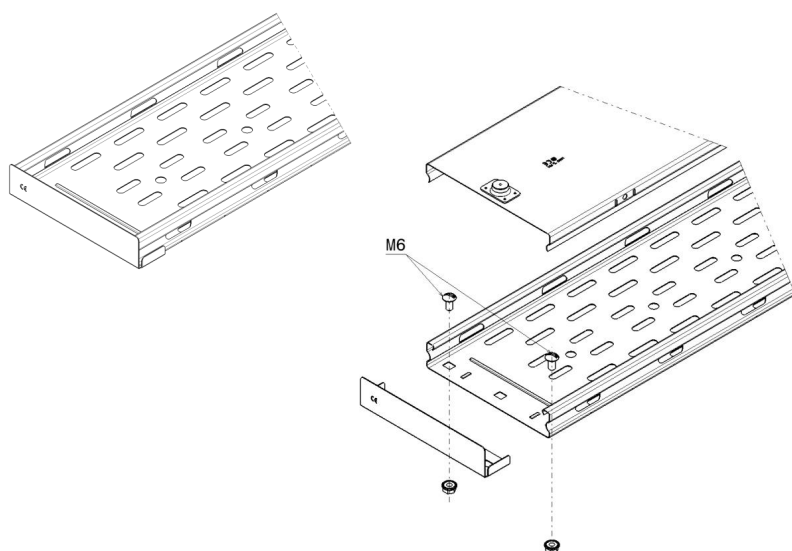

B- H50

The End-Cap in height 50 is assembled using 2 screws M6x12 in the sides of the cable tray.

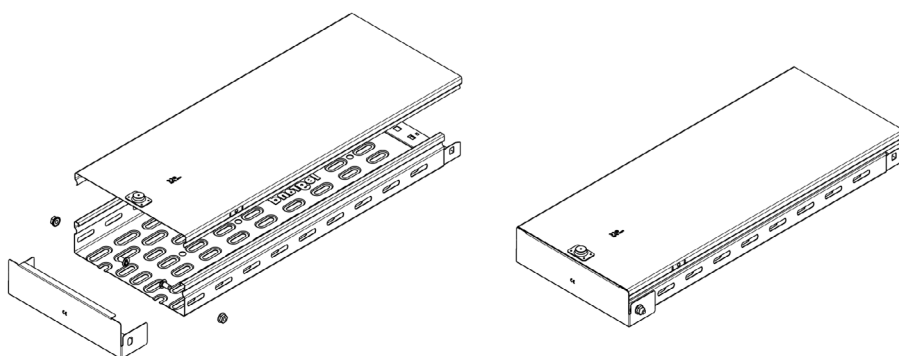

C- H60

The End-Cap in height 60 is assembled using 2 screws M6x12 in the sides of the cable tray.

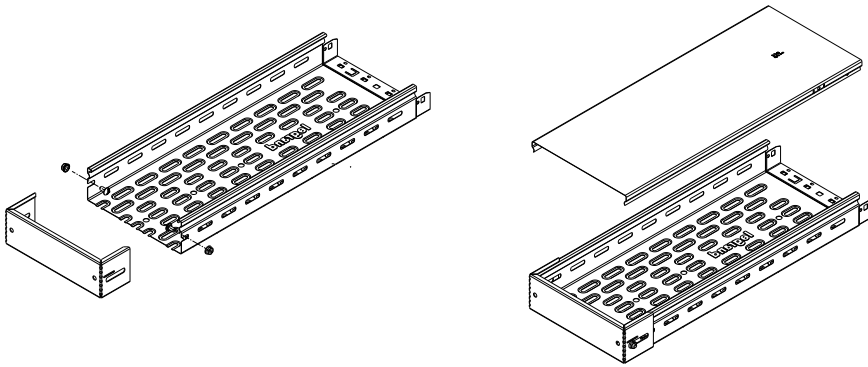

D- H100

The End-Cap in height 100 is assembled using 4 screws M6x12 in the sides of the cable tray.

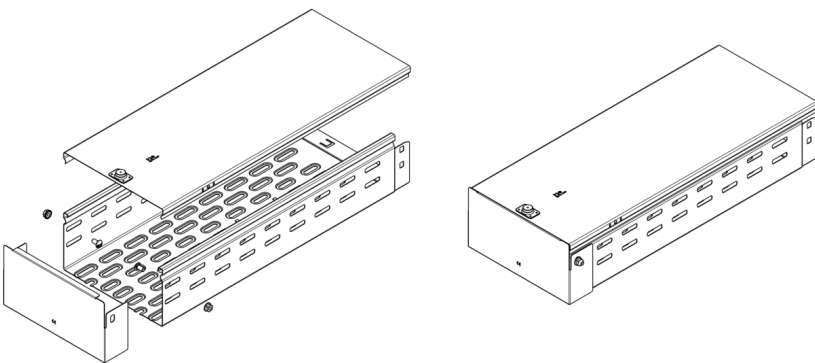

16- FLANGE CABINET

A- H50 FROM WIDTH 50 TO 300MM

Use flange to join cabinet with cable tray. Add the flange on the cable tray and fix it using 2 screws M6x12 in the sides of the cable tray. It is not necessary to disassemble the automatic coupler.

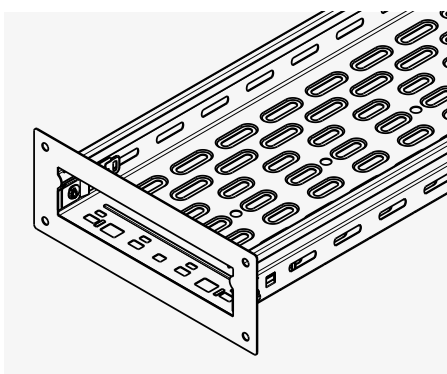
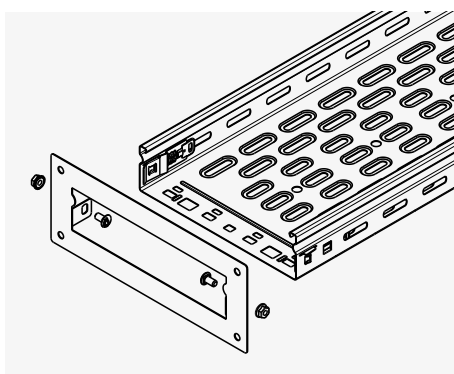

B- H50 FOR WIDTH FROM 400 TO 600MM

Use flange to join cabinet with cable tray. With the divided flange you have to remove the automatic coupler. Add the flange on the cable tray and fix it using 2 screws M6x12 in the sides of the cable tray. .

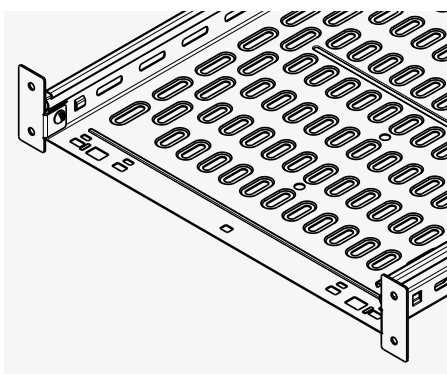
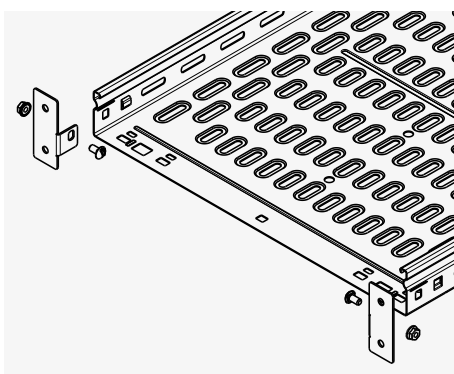

17- ELECTRICAL CONTINUITY OF CONNECTION (UL certification)

In USA the requirement of the electrical characteristics of a cable tray system is defined by the standard NEMA VE 1. Into section 5, paragraph 5.1 of the standard, is described the test method to verify the electrical continuity of connections (tray to tray, tray to cover, tray to accessories,...).

According to the Electrical National Code NFPA 70 there is also a second condition to satisfy independently by the electrical continuity since the cable tray systems could be used as an equipment grounding conductor; for UL is not possible to ignore this possibility. This is needed to declare for each dimension the minimum cross sectional area.

This information allows at the Customer to know, depending by the type of the protection device used, the section of the grounding wire needed to gain the minimum cross sectional area fixed by table 392.60A of NFPA 70 showed below.

Table 392.60(A) Metal Area Requirements for Cable Trays Used as Equipment Grounding Conductor

Maximum Fuse Ampere Rating, Circuit Breaker Ampere Trip Setting, or Circuit Breaker Protective Relay Ampere Trip Setting for Ground-Fault Protection of Any Cable Circuit in the Cable Tray System	Minimum Cross-Sectional Area of Metal ^a			
	Steel Cable Trays		Aluminum Cable Trays	
	mm ²	in. ²	mm ²	in. ²
60	129	0.20	129	0.20
100	258	0.40	129	0.20
200	451.5	0.70	129	0.20
400	645	1.00	258	0.40
600	967.5	1.50 ^b	258	0.40
1000	—	—	387	0.60
1200	—	—	645	1.00
1600	—	—	967.5	1.50
2000	—	—	1290	2.00 ^b

^aTotal cross-sectional area of both side rails for ladder or trough cable trays; or the minimum cross-sectional area of metal in channel cable trays or cable trays of one-piece construction.

^bSteel cable trays shall not be used as equipment grounding conductors for circuits with ground-fault protection above 600 amperes. Aluminum cable trays shall not be used as equipment grounding conductors for circuits with ground-fault protection above 2000 amperes.

When the tray doesn't meet the *minimum cross sectional area* fixed by the Table 392.60A of NFPA 70 and is used as an equipment grounding conductor (EGC) is needed to choose the *bonding jumper* and the *wire* depending by the *maximum ampere rating* used to protect the cable circuit to gain the minimum cross sectional area value.

A- EXAMPLE OF SIZING

We decide to start the sizing using a maximum fuse ampere rating of 60A installed on a H60x200 Lighting cable tray Item LG-487003.

First step is to check the minimum cross sectional area of metal required for an ampere rating of 60A on table 392.60(A). We obtain 129 mm².

Now we have to compare the obtained value with the cross sectional area of the cable tray; for LG-487003 is 118.2 mm² (check the value on the label of the product; however we resume all data for every items into the dedicated tables showed in the next chapter).

Minimum cross sectional area of metal must be major than cross sectional area of the cable tray. In this case we have to choose the size of the bonding jumper and sizing the section of grounding wire to gain the required sectional area.

▪ Choice of bonding jumper

Depending on the maximum ampere rating and according to the table 250.122 showed below select the size of the bonding jumper.

NEC 2008: Table 250.122		
Minimum Size Equipment Grounding Conductors for Grounding Raceway and Equipment		
Rating or Setting of Automatic Overcurrent Device in Circuit Ahead of Equipment, Conduit, etc., Not Exceeding (Amperes)	Size (AWG or kcmil)	
	Copper	Aluminum or Copper-Clad Aluminum*
15	14	12
20	12	10
30	10	8
40	10	8
60	10	8
100	8	6
200	6	4
300	4	2
400	3	1
500	2	1/0
600	1	2/0
800	1/0	3/0
1000	2/0	4/0
1200	3/0	250
1600	4/0	350
2000	250	400
2500	350	600
3000	400	600
4000	500	800
5000	700	1200
6000	800	1200

Note: Where necessary to comply with 250.4(A)(5) or (B)(4), the equipment grounding conductor shall be sized larger than given in this table.

*See installation restrictions in 250.120.

▪ **Choice of bonding jumper (continued)**

Using a maximum fuse ampere rating of **60A** we obtain **10 AWG** size of bonding jumper made by copper.
To convert AWG to mm² use the table showed below.

10 AWG are 6mm².

Wire Size Conversion Chart - American Wire Gauge to square millimeters							
AWG	mm ²	AWG	mm ²	AWG	mm ²	AWG	mm ²
30	0.05	18	0.75	6	16	4/0	120
28	0.08	17	1.0	4	25	300MCM	150
26	0.14	16	1.5	2	35	350MCM	185
24	0.25	14	2.5	1	50	500MCM	240
22	0.34	12	4.0	1/0	55	600MCM	300
21	0.38	10	6.0	2/0	70	750MCM	400
20	0.50	8	10	3/0	95	1000MCM	500

Choose the upper value of bonding jumpers showed into the next chapter.
In this case use item **585357**.

▪ **Mounting of bonding jumper (EGC)**

Use the standard kit to connect the grounding cable to the side of the cable tray.

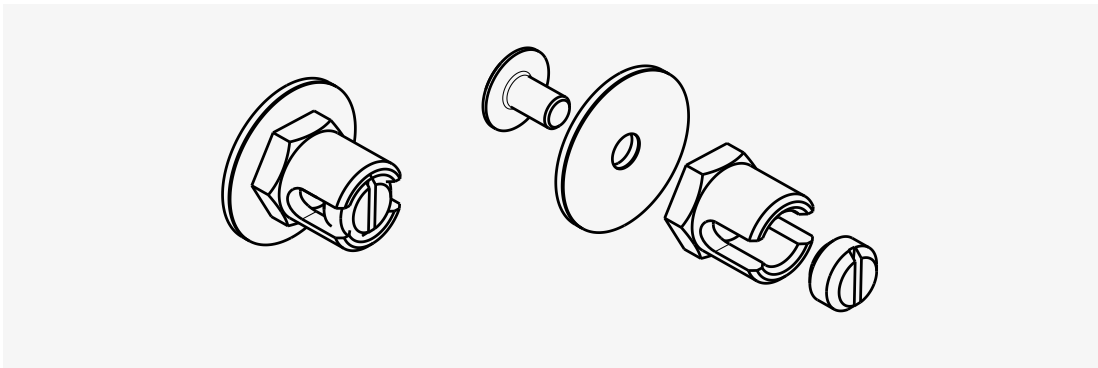

Item	Description	Material	Section (mm ²)
585357	BLT6-16 CU EARTH TERMINAL	COPPER	16
585367	BLT6-35 CU EARTH TERMINAL		35
585377	BLT6-50 CU EARTH TERMINAL		50

▪ **Mounting of bonding jumper (EGC) (continued)**

Place the bonding jumper (EGC) on the side of the cable tray and fasten it using the screw supplied with the kit.

Unscrew the cable clamp, place the bare grounding cable (depicted in green) and replace the clamping screw. Make sure the cable clamp holds the grounding wire tightly. For blind cable trays it is necessary to drill a hole in the side of the cable tray using a 7mm drill.

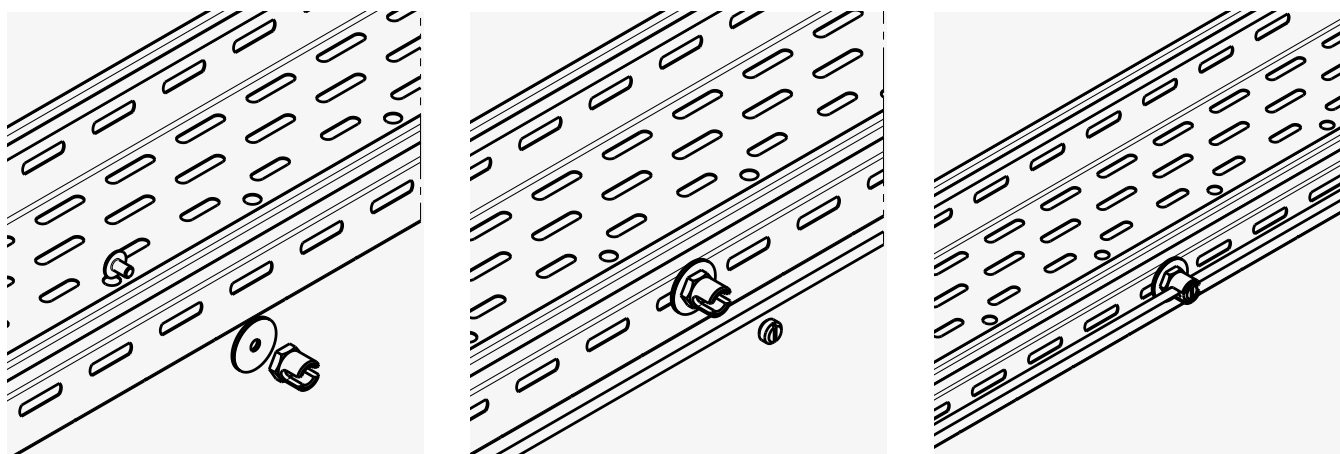

On each length of tray must be mounted minimum 1 bonding jumper and the AWG wire must be connected throughout the entire length of the cable trays system.

▪ **Calculation of cross sectional area to add**

Summarized into the table below the obtained data until yet.

Description	Size	Table
Protection device	60 (Ampere)	-
Bonding jumper	10 AWG (6 mm ²)	250.122
Minimum cross sectional area (A)	129 (mm ²)	392.60(A)
Cross sectional area of cable tray (B)	118.2 (mm ²)	On product label

We can calculate the cross sectional area to add making a difference between the minimum cross sectional area required by the table 392.60(A) and the cross sectional area of cable tray.

Cross sectional area to add = A - B = 129 - 118.2 = 10.8 mm².

▪ **Choice of wire dimension**

Knowing the cross sectional area to add use the table below to find the right dimension for the wire.

AWG	Diameter (mm)	Section (mm ²)
0000 (4/0)	11.684	107.22
000 (3/0)	10.405	85.01
00 (2/0)	9.266	67.43
0 (1/0)	8.252	53.49
1	7.348	42.41
2	6.544	33.61
3	5.827	26.67
4	5.189	21.15
5	4.62	16.77
6	4.115	13.3
7	3.655	10.55
8	3.264	8.37
9	2.906	6.63
10	2.588	5.26
11	2.305	4.17
12	2.052	3.31
13	1.828	2.63
14	1.623	2.08
15	1.45	1.65
16	1.291	1.31
17	1.149	1.04
18	1.024	0.823
19	0.912	0.653
20	0.812	0.519

AWG	Diameter (mm)	Section (mm ²)
21	0.723	0.411
22	0.644	0.324
23	0.573	0.259
24	0.511	0.205
25	0.455	0.162
26	0.405	0.128
27	0.361	0.102
28	0.321	0.0806
29	0.286	0.0649
30	0.255	0.0507
31	0.277	0.0401
32	0.202	0.0324
33	0.18	0.0255
34	0.16	0.0201
35	0.143	0.0159
36	0.127	0.0127
37	0.113	0.0103
38	0.101	0.0081
39	0.09	0.0062
40	0.08	0.0049
41	0.071	0.0039
42	0.064	0.0032
43	0.056	0.0025
44	0.051	0.0020



B- CROSS SECTIONAL AREA OF CABLE TRAYS (TABLES)

▪ Perforated cable trays

Type	Item	Height (mm)	Width (mm)	Junction type	Finishing	Cross sectional area (mm ²)	Cross sectional area (in ²)
H27 M/F PERFORATED	LG-480044	27	50	M/F	GS/PG/Z	58.8	0.09
	LG-480045	27	77			66.6	0.10
	LG-480046	27	100			80.4	0.12
	LG-480047	27	150			110.4	0.17
	LG-485048	27	200			140.4	0.22
	LG-485049	27	300			189.6	0.29
	LG-480050	27	400			345.6	0.54
	LG-480051	27	500			410.4	0.64
	LG-482144	27	50			GC/HDG/C	58.8
	LG-482145	27	77		66.6		0.10
	LG-482146	27	100		80.4		0.12
	LG-482147	27	150		110.4		0.17
	LG-485248	27	200		140.4		0.22
	LG-485249	27	300		198.6		0.29
	LG-482050	27	400		345.6		0.54
	LG-482051	27	500		410.6		0.64

Type	Item	Height (mm)	Width (mm)	Junction type	Finishing	Cross sectional area (mm ²)	Cross sectional area (in ²)
H50 M/F AUTO PERFORATED	LG-481175	50	77	M/F + Auto	GS/PG/Z	96.0	0.15
	LG-481100	50	100			109.8	0.17
	LG-481150	50	150			139.8	0.22
	LG-481201	50	200			165.6	0.26
	LG-481300	50	300			261.0	0.40
	LG-481400	50	400			374.4	0.58
	LG-481500	50	500			439.2	0.68
	LG-481600	50	600			504.0	0.78

Type	Item	Height (mm)	Width (mm)	Junction type	Finishing	Cross sectional area (mm ²)	Cross sectional area (in ²)
H50 M/F PERFORATED	LG-480052	50	50	M/F	GS/PG/Z	88.2	0.14
	LG-480852	50	77			96.0	0.15
	LG-480053	50	100			109.8	0.17
	LG-480054	50	150			139.8	0.22
	LG-480155	50	200			165.6	0.26
	LG-480156	50	300			261.0	0.40
	LG-480057	50	400			374.4	0.58
	LG-480058	50	500			439.2	0.68
	LG-480059	50	600			504.0	0.78
	LG-482052	50	50		GC/HDG/C	88.2	0.14
	LG-482852	50	77			96.0	0.15
	LG-482053	50	100			109.8	0.17
	LG-482054	50	150			139.8	0.22
	LG-482155	50	200			165.6	0.26
	LG-482156	50	300			261.0	0.40
	LG-482057	50	400			374.4	0.58
	LG-482058	50	500			439.2	0.68
	LG-482059	50	600			504.0	0.78

Type	Item	Height (mm)	Width (mm)	Junction type	Finishing	Cross sectional area (mm ²)	Cross sectional area (in ²)
H60 M/F AUTO PERFORATED	LG-480110	60	77	M/F + Auto	GS/PG/Z	108.0	0.17
	LG-480111	60	100			121.8	0.19
	LG-480112	60	150			151.8	0.24
	LG-480113	60	200			177.6	0.28
	LG-480114	60	300			276.0	0.43
	LG-480115	60	400			392.4	0.61
	LG-480116	60	500			457.2	0.71
	LG-480117	60	600			522.0	0.81

Type	Item	Height (mm)	Width (mm)	Junction type	Finishing	Cross sectional area (mm ²)	Cross sectional area (in ²)
H60 M/F PERFORATED	LG-481219	60	77	M/F	GS/PG/Z	108.0	0.17
	LG-481220	60	100			121.8	0.19
	LG-481221	60	150			151.8	0.24
	LG-481222	60	200			177.6	0.28
	LG-481223	60	300			276.0	0.43
	LG-481224	60	400			392.4	0.61
	LG-481225	60	500			547.2	0.71
	LG-481226	60	600			522.0	0.81
	LG-482110	60	77		GC/HDG/C	108.0	0.17
	LG-482111	60	100			121.8	0.19
	LG-482112	60	150			151.8	0.24
	LG-482113	60	200			177.6	0.28
	LG-482114	60	300			276.0	0.43
	LG-482115	60	400			392.4	0.61
	LG-482116	60	500			547.2	0.71
	LG-482117	60	600			522.0	0.81

Type	Item	Height (mm)	Width (mm)	Junction type	Finishing	Cross sectional area (mm ²)	Cross sectional area (in ²)
H60 CPC PERFORATED	LG-481260	60	77	M/F + Auto	GS/PG/Z	80.4	0.12
	LG-481261	60	100			94.2	0.15
	LG-481262	60	150			124.0	0.19
	LG-481263	60	200			150.0	0.23
	LG-481264	60	300			241.5	0.37
	LG-481265	60	400			351.0	0.54
H60 MBR PERFORATED	LG-481823	60	77	M/F + Auto	GS/PG/Z	116.4	0.18
	LG-481824	60	100			130.2	0.20
	LG-481825	60	150			160.2	0.25
	LG-481826	60	200			190.2	0.29
	LG-481827	60	300			312.8	0.48
H60 LIGHTING PERFORATED	LG-487000	60	77	M/F + Auto	GS/PG/Z	70.8	0.11
	LG-487001	60	100			84.6	0.13
	LG-487002	60	150			88.2	0.14
	LG-487003	60	200			118.2	0.18
	LG-487004	60	300			207.0	0.32
	LG-487005	60	400			309.6	0.48



Type	Item	Height (mm)	Width (mm)	Junction type	Finishing	Cross sectional area (mm ²)	Cross sectional area (in ²)
H60 SYMMETRICAL PERFORATED	LG-480561	60	77	Coupler	GS/PG/Z	108.0	0.17
	LG-480562	60	100			121.8	0.19
	LG-480563	60	150			151.8	0.24
	LG-480564	60	200			177.6	0.28
	LG-480565	60	300			276.0	0.43
	LG-480566	60	400			392.4	0.61
	LG-480567	60	500			457.2	0.71
	LG-480568	60	600			522.0	0.81
	LG-480571	60	77		GC/HDG/C	108.0	0.17
	LG-480572	60	100			121.8	0.19
	LG-480573	60	150			151.8	0.24
	LG-480574	60	200			177.6	0.28
	LG-480575	60	300			276.0	0.43
	LG-480576	60	400			392.4	0.61
	LG-480577	60	500			457.2	0.71
	LG-480578	60	600			522.0	0.81
H60 VANDER-LANDE PERFORATED	LG-487150	60	77	Coupler	GS/PG/Z	80.4	0.12
	LG-487151	60	100			94.2	0.15
	LG-487152	60	150			124.2	0.19
	LG-487153	60	200			200.0	0.31
	LG-487154	60	300			298.8	0.45
	LG-487155	60	400			351.0	0.54
H60 LEGRAND (30X60) PERFORATED	LG-487054	60	77	Coupler	GS/PG/Z	80.4	0.12
	LG-487055	60	100			94.2	0.15
	LG-487056	60	150			124.2	0.19
	LG-487057	60	200			200.0	0.31
	LG-487058	60	300			298.8	0.45
	LG-487059	60	400			351.0	0.54

Type	Item	Height (mm)	Width (mm)	Junction type	Finishing	Cross sectional area (mm ²)	Cross sectional area (in ²)
H100 M/F PERFORATED	LG-480068	100	100	M/F	GS/PG/Z	161.4	0.25
	LG-480069	100	150			191.4	0.30
	LG-481070	100	200			217.2	0.34
	LG-481071	100	300			325.5	0.50
	LG-480072	100	400			451.8	0.70
	LG-480073	100	500			516.6	0.80
	LG-480107	100	600			581.4	0.90
	LG-482068	100	100		GC/HDG/C	161.4	0.25
	LG-482069	100	150			191.4	0.30
	LG-482170	100	200			217.2	0.34
	LG-482171	100	300			325.5	0.50
	LG-482172	100	400			451.8	0.70
	LG-482173	100	500			516.6	0.80
	LG-482106	100	600			581.4	0.90

Type	Item	Height (mm)	Width (mm)	Junction type	Finishing	Cross sectional area (mm ²)	Cross sectional area (in ²)
H50 M/F AUTO BLIND	LG-481901	50	77	M/F + Auto	GS/PG/Z	103.2	0.16
	LG-481902	50	100			117.0	0.18
	LG-481903	50	150			147.0	0.23
	LG-481904	50	200			148.2	0.23
	LG-481905	50	300			308.7	0.48
	LG-481906	50	400			398.7	0.62
	LG-481907	50	500			488.7	0.76
	LG-481908	50	600			578.7	0.90

Type	Item	Height (mm)	Width (mm)	Junction type	Finishing	Cross sectional area (mm ²)	Cross sectional area (in ²)
H50 M/F BLIND	LG-480020	50	50	M/F	GS/PG/Z	94.2	0.15
	LG-481252	50	77			105.0	0.16
	LG-480021	50	100			118.8	0.18
	LG-480022	50	150			148.8	0.23
	LG-480023	50	200			178.8	0.28
	LG-480024	50	300			354.6	0.55
	LG-480078	50	400			444.6	0.69
	LG-480079	50	500			534.6	0.83
	LG-480081	50	600			624.6	0.97
	LG-482020	50	50			GC/HDG/C	94.2
	LG-482021	50	77		105.0		0.16
	LG-482074	50	100		118.8		0.18
	LG-482075	50	150		148.8		0.23
	LG-482076	50	200		178.8		0.28
	LG-482077	50	300		354.6		0.55
	LG-482078	50	400		444.6		0.69
	LG-482079	50	500		534.6		0.83
	LG-482080	50	600		624.6		0.97

Type	Item	Height (mm)	Width (mm)	Junction type	Finishing	Cross sectional area (mm ²)	Cross sectional area (in ²)
H60 M/F AUTO BLIND	LG-481120	60	77	M/F + Auto	GS/PG/Z	117.0	0.18
	LG-481121	60	100			130.8	0.20
	LG-481122	60	150			160.8	0.25
	LG-481123	60	200			190.8	0.30
	LG-481124	60	300			313.5	0.49
	LG-481125	60	400			462.6	0.72
	LG-481126	60	500			552.6	0.86
	LG-481127	60	600			642.6	1.00

Type	Item	Height (mm)	Width (mm)	Junction type	Finishing	Cross sectional area (mm ²)	Cross sectional area (in ²)
H60 SYMMETRICAL BLIND	LG-480301	60	77	Coupler	GS/PG/Z	124.8	0.19
	LG-480302	60	100			138.6	0.21
	LG-480303	60	150			168.6	0.26
	LG-480304	60	200			198.6	0.31
	LG-480305	60	300			323.3	0.50
	LG-480306	60	400			474.3	0.74
	LG-480307	60	500			564.3	0.87
	LG-480308	60	600			654.3	1.01
	LG-481061	60	77			GC/HDG/C	124.8
	LG-481062	60	100		138.6		0.21
	LG-481063	60	150		168.6		0.26
	LG-481064	60	200		198.6		0.31
	LG-481065	60	300		323.3		0.50
	LG-481066	60	400		474.3		0.74
	LG-481067	60	500		564.3		0.87
	LG-481069	60	600		654.3		1.01

Type	Item	Height (mm)	Width (mm)	Junction type	Finishing	Cross sectional area (mm ²)	Cross sectional area (in ²)
H100 M/F BLIND	LG-480030	100	100	M/F	GS/PG/Z	168.0	0.26
	LG-480031	100	150			198.0	0.31
	LG-480032	100	200			228.0	0.35
	LG-480033	100	300			360.0	0.56
	LG-480092	100	400			518.4	0.80
	LG-480093	100	500			608.4	0.94
	LG-480106	100	600			698.4	1.08
	LG-482088	100	100		GC/HDG/C	168.0	0.26
	LG-482089	100	150			198.0	0.31
	LG-482090	100	200			228.0	0.35
	LG-482091	100	300			360.0	0.56
	LG-482092	100	400			518.4	0.80
	LG-482093	100	500			608.4	0.94
	LG-482107	100	600			698.4	1.08

18- H60 - FIRE RESISTANT CONFIGURATION E30, E60, E90

For details regarding the construction of a Fire Resistant (FR) cable tray installation according DIN4102-12, see the certificate issued by the German Authorities: the ABP reg.no. P-MPA-E-15-007, which is leading over this mounting instruction. Whenever in doubt or if you have any questions, please contact the local Legrand office.

Key figures:

- Max. support distance for any FR installation is 1,5m
- Max. total cable load is 20 daN/m* (for CRP constructions 10 daN/m)
- Max. 2 cable tray installations over each other on the same support
- Mounting a cover is not allowed
- For vertical installation, use GLO-4 ladder
- Any installation over a Fire Resistance cable tray installation has to meet at least the same FR classification
- Make sure the anchors used for installation to wall or ceiling meet at least the same FR classification at given load
- Only perforated types of galvanized cable trays are allowed
- Coating (paint or HD-zinc) is allowed to max. 160 µm thickness

*[1 daN ≈ 1kg].

A- CABLE TRAY ASSEMBLING

To connect cable trays, screws are always necessary:

- Male – Female (auto) cable trays: Use 3 screws M6x12 to securely connect both sides and the middle of the bottom. Additionally, bend the 2 clips in the male end trough the perforation in the female end until they point outwards again (see below). Auto clips (if present) do not have to be removed
- Symmetrical cable trays are connected using the "Eclis" coupler plate (see 3.1.3). Additionally add 2 screws per coupler plate to securely fasten it to both trays. For width 300mm and 400mm, mounting an bottom plate is necessary as well.

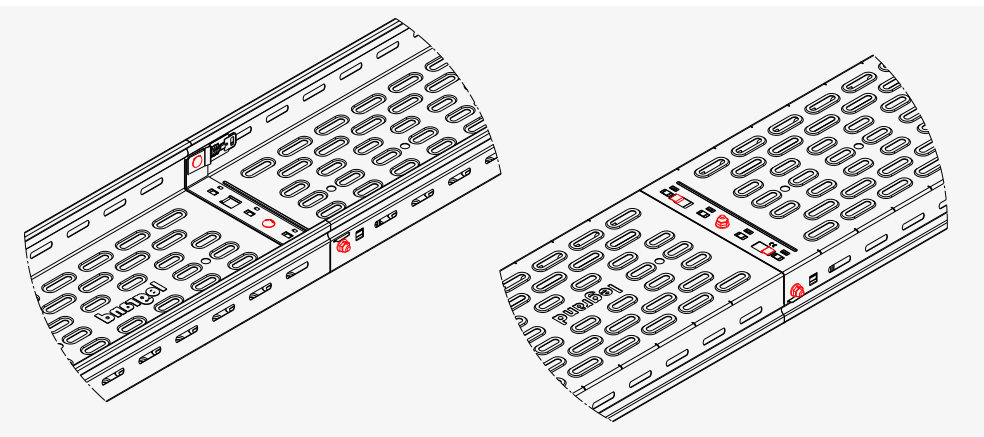

B- CRP CONFIGURATION

The cable tray is connected to the CRP bracket using 2 screws M6x12 for each support. The CRP bracket is mounted to the wall using 2 anchors M10. For the CRP configuration, the SWL is 10daN/m.

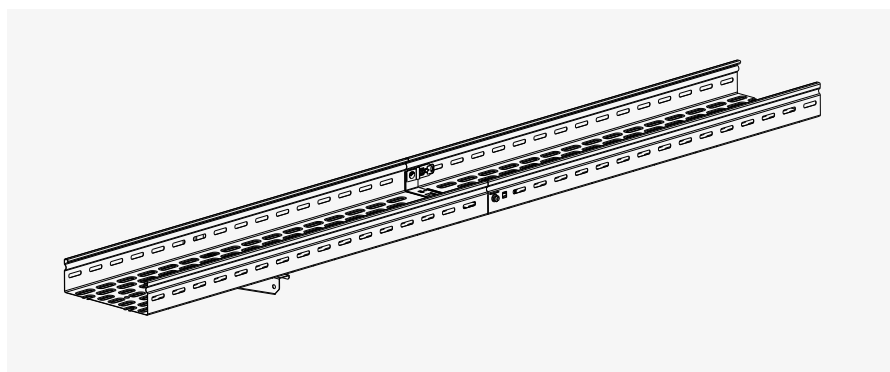

C- CB BRACKET AND THREADED ROD CONFIGURATION

The cable tray is connected to the CB bracket using 2 screws M6x12 for each support.

The M10 threaded rod is mounted to the cable tray using a hook fixed with one screw M6x12.

The CB bracket is mounted to the wall using 1 anchor M10. To mount the ceiling bracket to the ceiling use 1 anchor M8.

For the CB configuration the safety working load is 20daN/m.

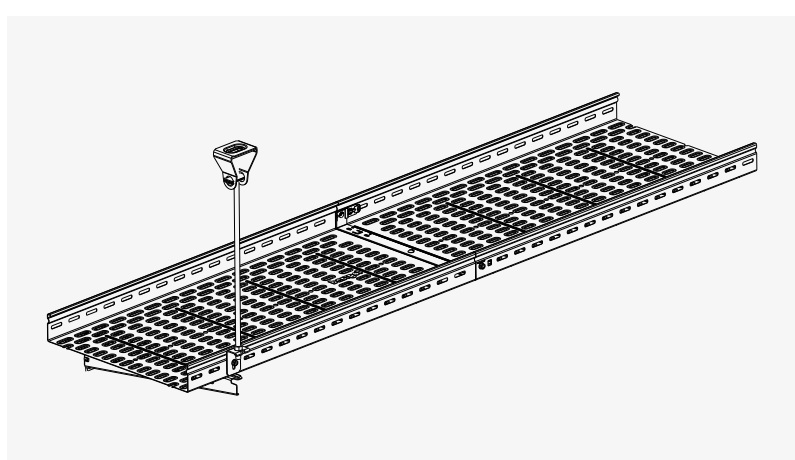

Alternative: the M10 threaded rod is allowed to be led back to the wall for fixture.
The angle has to the horizontal plane is $>45^\circ$.
The Ceiling bracket is mounted to the wall using 1 anchor M8.
For the CB configuration the safety working load is 20daN/m.

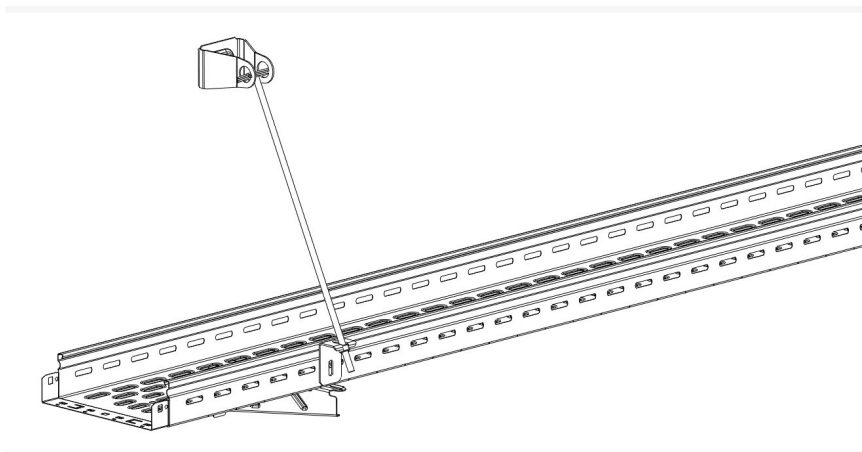

D- R21S TRAPEZE CONFIGURATION

The cable tray is connected to the R21S bracket using 2 screws M6x12 for each support.

The threaded rod is mounted to the rail using an M10 nut. The use of a washer (M10x40x2,5; see detail C) is allowed. Max. 2 cable trays allowed on the same threaded rod suspension. For this configuration the safety working load is 20daN/m per cable tray.

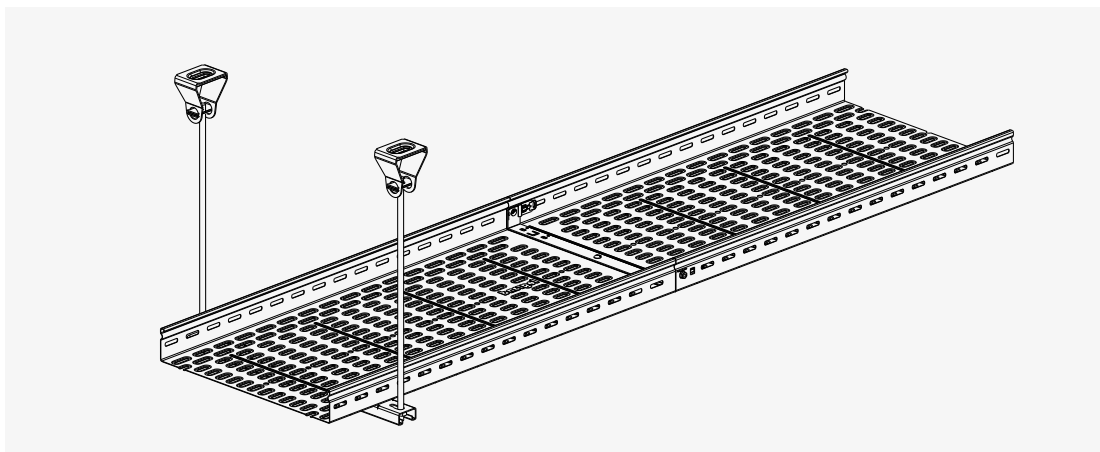

The threaded rod can be mounted directly to the ceiling using an M10 anchor with internal thread, or in the case of a sloped ceiling, use a ceiling bracket and an M10 anchor with external thread.

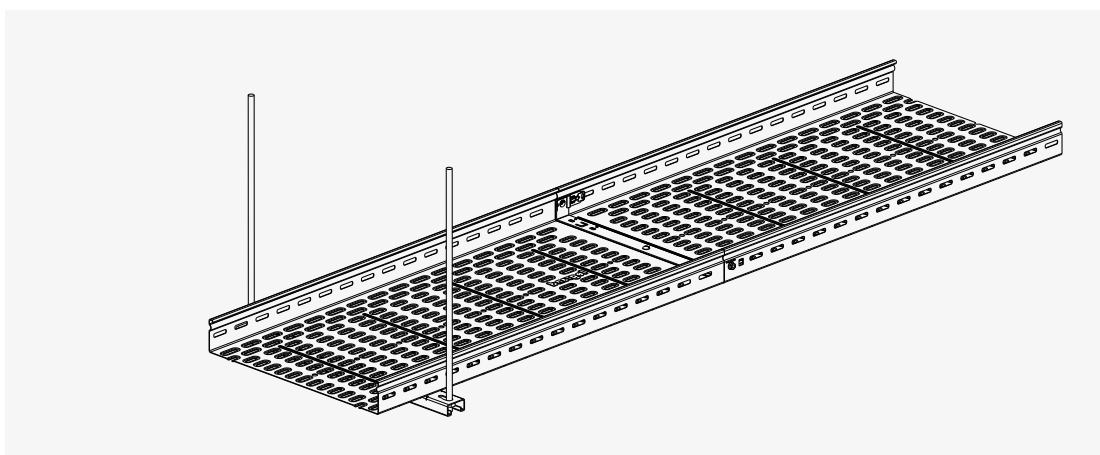

E- U55 PENDANT AND CB BRACKET CONFIGURATION

Mount the CB bracket on the pendant using M8x20 bolt and nut.

The cable tray is connected to the CB bracket using 2 screws M6x12 for each support. The M10 threaded rod is mounted to the cable tray using a hook fixed with one screw M6x12. For this configuration the safety working load is 20daN/m.

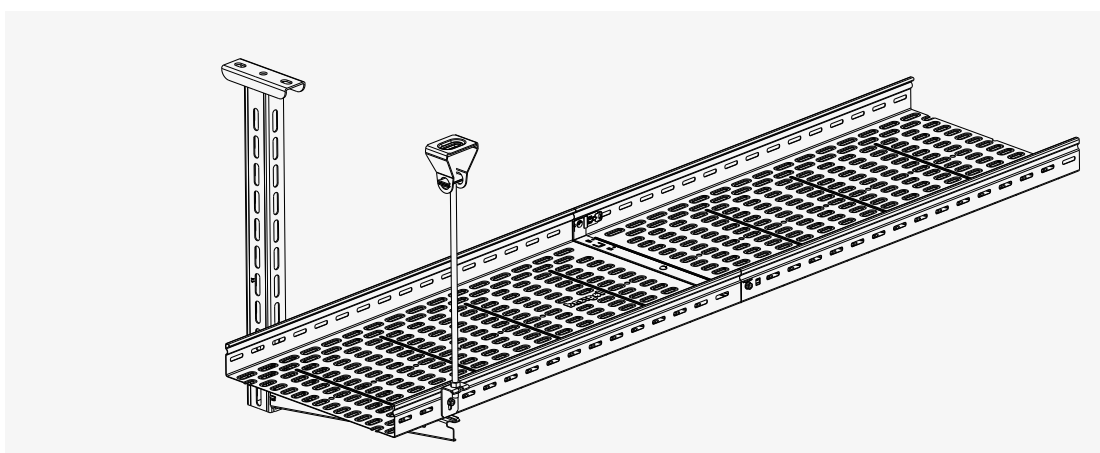

F- U55 PENDANT AND CB BRACKET MULTIPLE CONFIGURATION



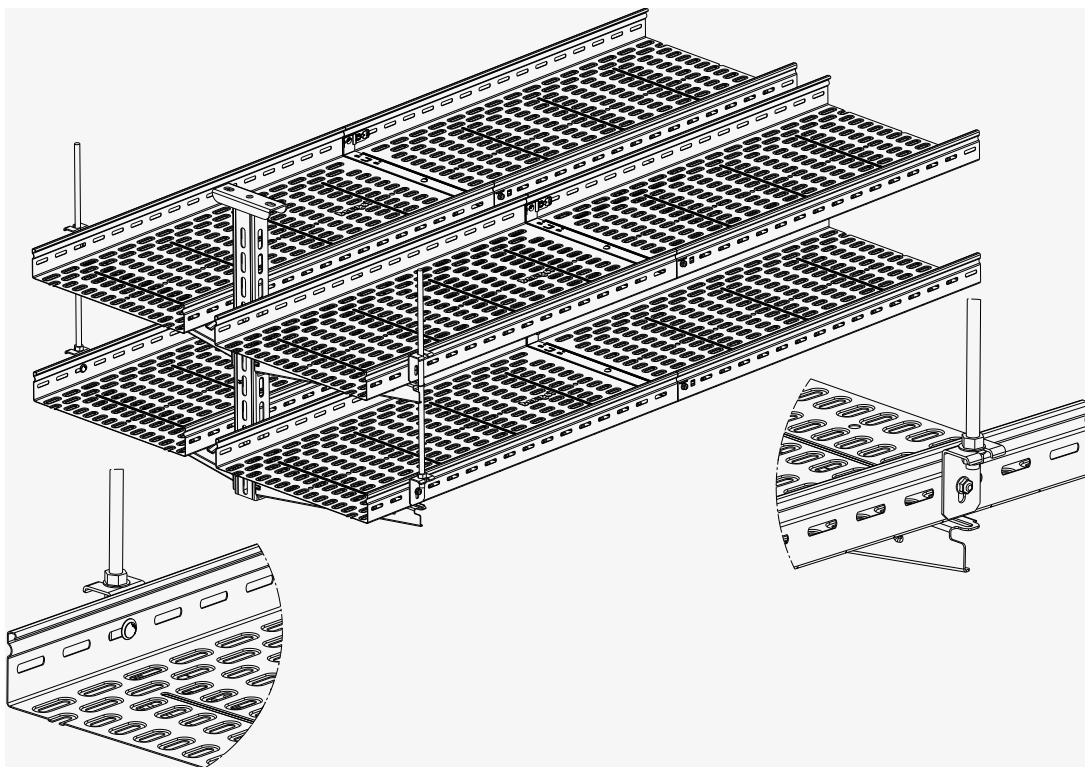

See below for the configuration of the suspension. The U55 pendant is in the middle and the CB brackets point to both sides. Max. 2 cable trays are allowed over each other, on each side of the U55 suspension (total = 4).

The cable tray is mounted to the CB bracket using 2 screws M6x12 for each support. The M10 threaded rod is mounted to the cable tray using a hook fixed with one screw M6x12. For this configuration the safety working load is 20daN/m per cable tray way.





FOLLOW US ON

- @ legrand.com
-  youtube.com/user/legrand
-  facebook.com/Legrand
-  twitter.com/Legrand
-  pinterest.com/legrandgroup
-  instagram.com/legrandnews



Head Office
and International Department
87045 Limoges Cedex - France
Tel: + 33 (0) 5 55 06 87 87
Fax: + 33 (0) 5 55 06 74 55