

## GREEN-I

### MINI RECESSED DALI LIGHTING CONTROL SENSOR

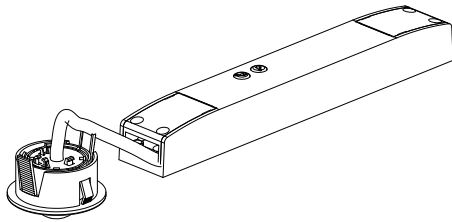

GEMR-W-DD (White)  
GEMR-B-DD (Black)

#### CONTENTS

1. USE .....	1
2. TECHNICAL CHARACTERISTICS .....	1
3. DIMENSIONS .....	2
4. CONNECTION .....	2
5. INSTALLATION .....	4
6. SETTINGS .....	6
7. COVERAGE PERFORMANCE .....	8
8. FONCTIONNEMENT .....	8
9. MAINTENANCE .....	9
10. STANDARDS .....	9

#### 1. USE

This miniature PIR (passive infrared) presence detector provides automatic control of lighting loads with optional manual control. This model can be used for switching control of incandescent, fluorescent and compact fluorescent loads. The unit detects movement using a PIR sensor and turns the load on. When an area is no longer occupied, the load will switch off after an adjustable timeout period.

These units come complete with accessories allowing flush mounting in suspended ceilings or surface mounting on ceilings, or side mounting on a luminaire.

It is quick and easy to set, using potentiometers or an IR remote control (GE-HS)

Time Delay: 10sec to 45min  
Light Level Setpoint: 5... 2000lux

#### 2. TECHNICAL CHARACTERISTICS

##### 2.1 Technical data

Voltage: 100-240V~  
Frequency: 50 / 60 Hz  
No-load power consumption: 0.1W  
Output by normally open contact connected to phase  
Terminal capacity: 1,5mm<sup>2</sup>  
Flush-mounting diameter: 40 mm  
Weight: 106.9g  
Impact resistance: IK04  
Penetration by solid bodies and liquids: IP20  
Operating temperature: -5°C to +30°C  
Storage temperature: -20°C to +70°C

#### 2. TECHNICAL CHARACTERISTICS (Continued)

##### 2.2 Features

**Power Supply:**  
The relay output dedicated to lightings, switching loads at the zero crossing.

The connections for an auxiliary switch that can be used to turn on the lighting manually.

The trimmer which is used time delay setpoint and daylight level setpoint

##### Sensor Head

The sensor (pyroelectric technology) with its lens for sensing movement. The daylight sensor measuring the natural and artificial light for driving lightings according to the daylight setpoint.

The Infrared protocol to configure.

- o Time delay
- o Daylight setpoint
- o Launch test mode
- o PIR Sensitivity

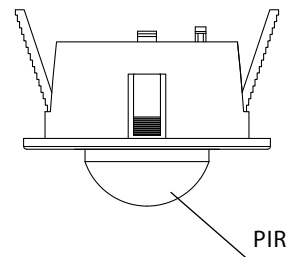

Scan the QR Code and access the technical documentation

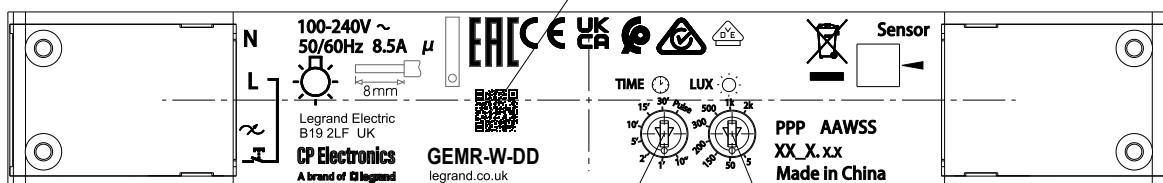

Time delay setpoint

Light level setpoint

## MINI RECESSED DALI LIGHTING CONTROL SENSOR

### 2. TECHNICAL CHARACTERISTICS (Continued)

#### 2.3 Load

Control DALI lightings in broadcast and providing DALI power for 30 DALI ballasts

Ballast number (guaranteed): 20

Ballast number (max): 30

Output current (guaranteed): 56mA / 16V

Output current (max): 75mA / 16V

### 3. DIMENSIONS

#### 3.1 Sensor head

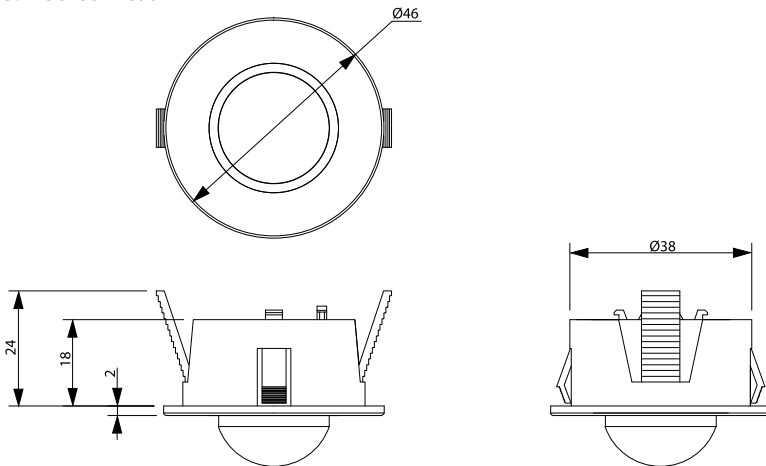

#### 3.2 Power supply

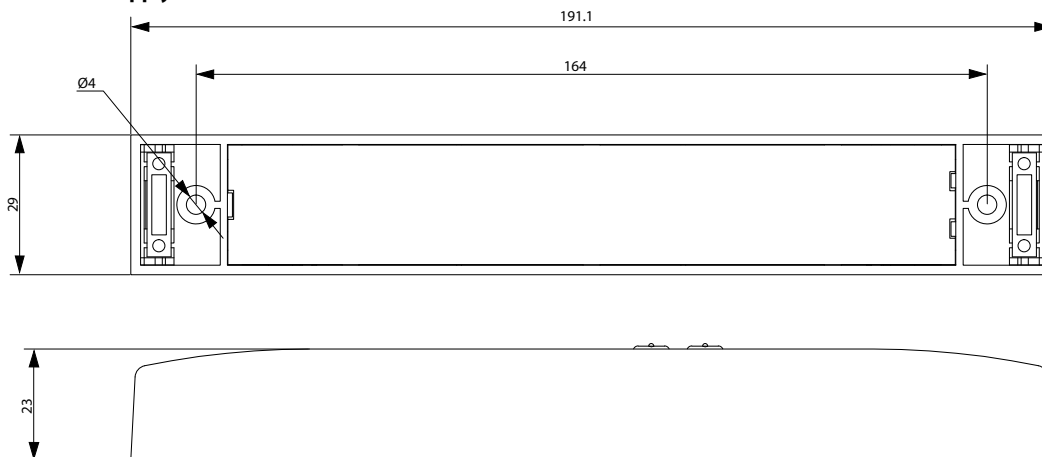

### 4. CONNECTION

Wire the products as shown in the diagram

The auxiliary switch is optional. It can be used to switch the lighting on and off.

#### 4.1 Wiring with auxiliary control

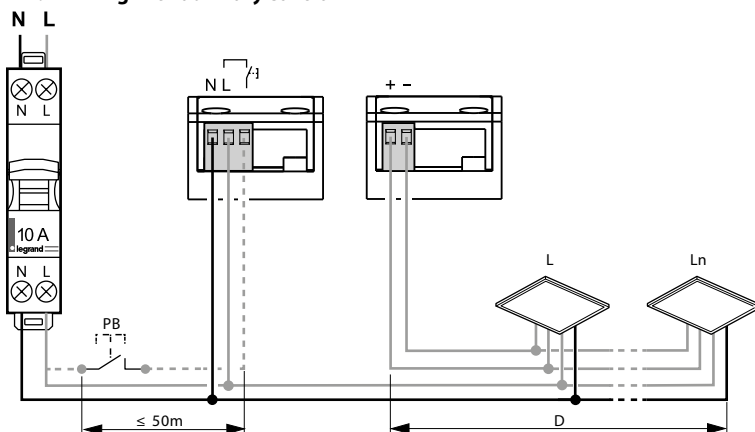

#### Bus DALI / DALI Bus

D	
$\leq 100$ m	0.5 mm <sup>2</sup>
$\leq 150$ m	0.75 mm <sup>2</sup>
$\leq 300$ m	1.5 mm <sup>2</sup>

# MINI RECESSED DALI LIGHTING CONTROL SENSOR

## 5. INSTALLATION

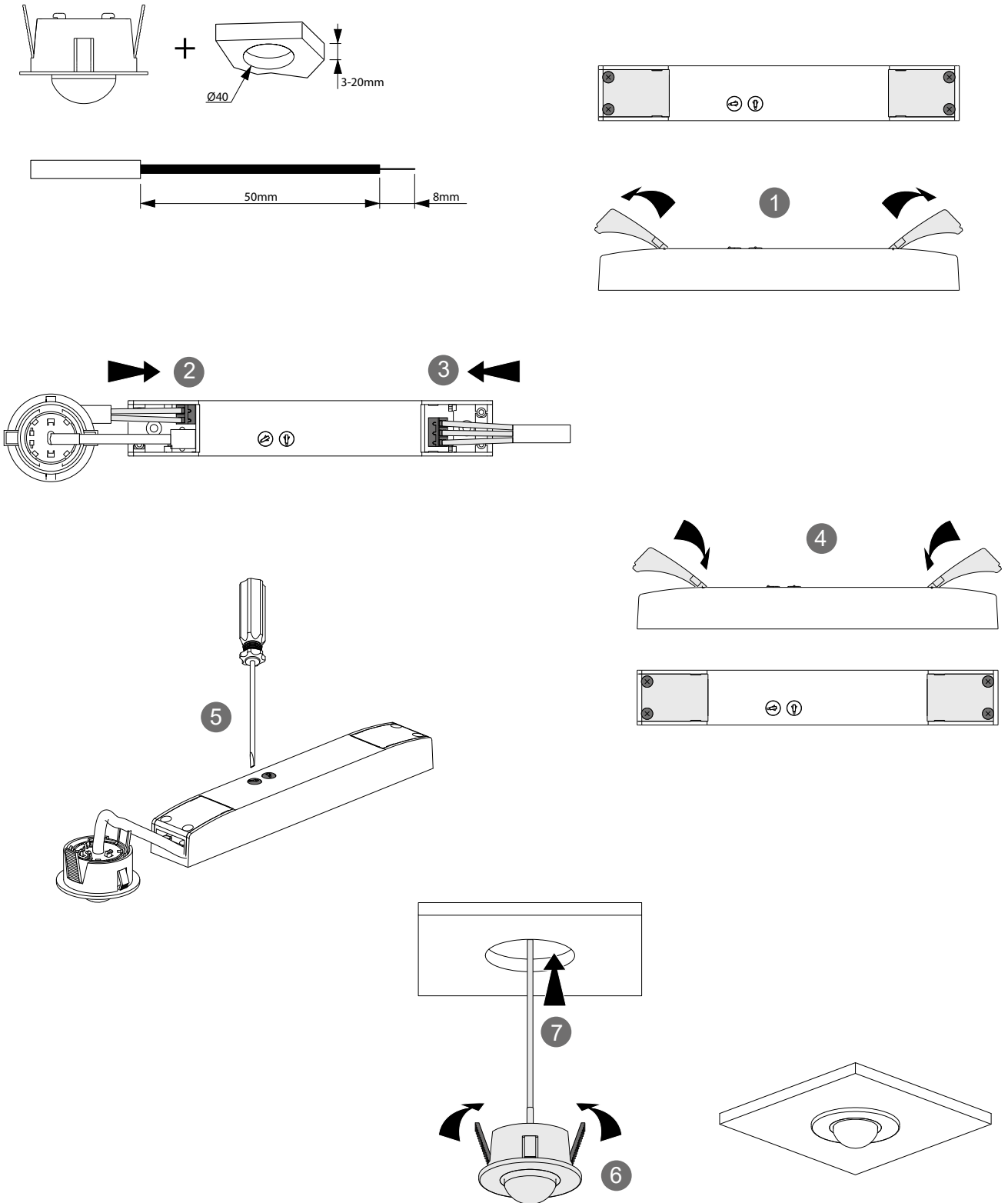

MINI RECESSED DALI LIGHTING CONTROL SENSOR

6. SETTINGS

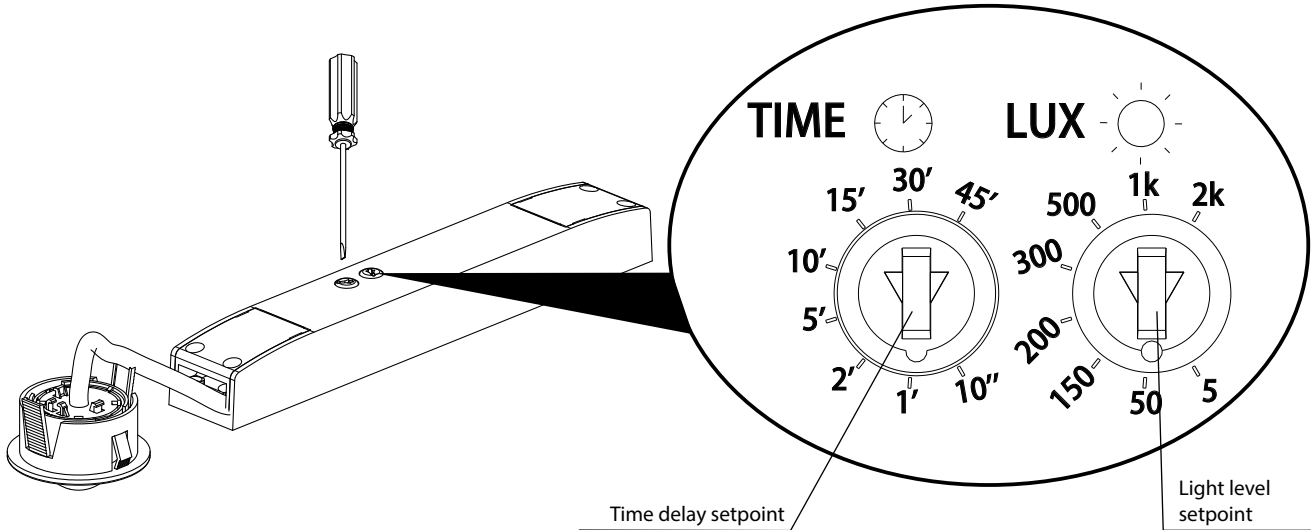

6.1 Setting by Trimmer

The product is set with this trimmer's positions.

**Time delay setpoint:** Time for which light is switched on following detection.

**Light level setpoint:** Light level setpoint value below which the light is switched on and above which the light is switched off.

Position	Trimmer daylight	Trimmer time delay
1	5 lux (Min)	10 sec
2	50 lux	1 min
3	150 lux	2 min
4	200 lux	5 min
5	300 lux	10 min
6	500 lux	15min
7	1000 lux	30 min
8	2000 lux (Max)	45 min

**Light level Max:** Light will always be turn on/off no matter light level.  
**Pulse:** The relay output is driven with short pulse (1s) spaced to 10s for driving a timer lag switch. Combined with a remote time-switch, the detector is ideal for stairwells and corridors.  
 The time set on the time switch determines how long the load is switched on following a signal detection.

**Factory Settings:**  
 Trimmer daylight: position 8 (max)  
 Trimmer time delay: position 1 (10sec)

6.2 Setting by Infrared remote control (Cat. No GE-HS)

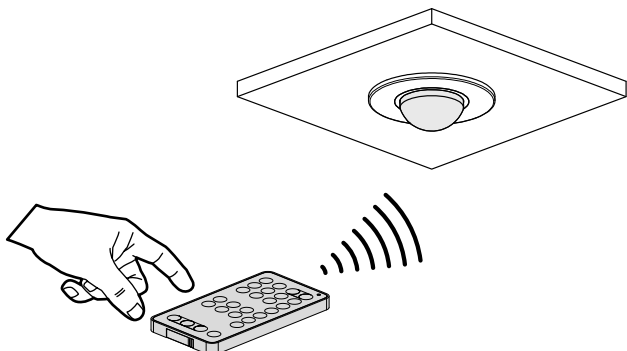

6.2 Setting by Infrared remote control (continued)

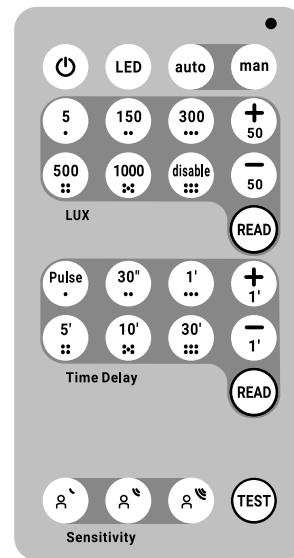

Notes 1: Auto on/Auto off mode:

Automatic switch-on:  
 - On detection of presence if the natural light level is insufficient.  
 Automatic switch-off:  
 - If no presence is detected and at the end of the set time delay  
 - Or if the natural light level is sufficient  
 Another detection causes automatic switch-on if there is insufficient light.

Notes 2: Manual on/Auto off mode:

Manual switch-on, automatic switch-off:  
 - When no presence is detected and at the end of the set time delay. After switch-off, any new detection within a 30 second period triggers an automatic switch-on.  
 After 30 seconds the device is switched on via a manual switch.

Note 3: Test Mode:

This mode bypass parameters for 10 minutes.  
 Every detection switch ON the motion LED (in purple) for 1sec and drives the lightings for 5 seconds.  
 After these 5 seconds, if no motion is sensed, the lightings turn OFF, else the 5 seconds delay is refreshed (test mode restarts).  
 The 10 minutes test timer is reset only if remote control test button is pushed again.

MINI RECESSED DALI LIGHTING CONTROL SENSOR

6. SETTINGS (Continued)

6.2 Setting by Infrared remote control (continued)

TYPE	KEY	NAME	DESCRIPTION	Comment
Parameter		Load ON/OFF	Turn ON/OFF the connected loads	After the setting is successful, the purple LED on the product blinks quickly three times.
		Motion LED ON/OFF	Enables or Disables the motion detection LED (green)	
		Auto ON Auto OFF	The load will be switched on and off automatically	
		Manuel ON Auto OFF	Manual switching on by pressing the push button / Automatic switching off at the end of the timer period	
Light level Setpoint		5 LUX	Set light level to 5 LUX	Example : the sensor's LED blinks yellow 3 times = light level is set to 300 LUX or the closest value (250 or 350 LUX).
		150 LUX	Set light level to 150 LUX	
		300 LUX	Set light level to 300 LUX	
		500 LUX	Set light level to 500 LUX	
		1000 LUX	Set light level to 1000 LUX	
		Disable light level Regulation	Light will always be turn on/off no matter light level	
		Read light level	Upon activation the sensor yellow LED will blink «x» times to indicate the set values for LUX	
		Increase 50 lux	Increase by 50 LUX the set LUX level (maximum value when pressing + is 2000 LUX)	
		Decrease 50 lux	Decrease by 50 LUX the set LUX level	
	Time delay		Pulse	
		30 seconds	Set time delay to 30s	
		1 minute	Set time delay to 1min	
		5 minutes	Set time delay to 5min	
		10 minutes	Set time delay to 10min	
		30 minutes	Set time delay to 30min	
		Read time delay	Upon activation the sensor blue LED will blink «x» times to indicate the set values for time delay	
		Increase 1 minute	Increase by 1min the set the time delay (maximum value when pressing + is 60 min)	
		Decrease 1 minute	Decrease by 1min the set the time delay	
Sensivity			PIR sensitivity	1.Low 2.Medium 3.High
Test Mode		Test Mode	Test mode is activated during 10min and the time delay is 5s.	Temporary sets values to : LUX disabled Delay 5s After test period, values return to their original settings and the test can be interrupted by pushing the button once more.

## MINI RECESSED DALI LIGHTING CONTROL SENSOR

### 6. SETTINGS (Continued)

#### 6.3 Pilot lamp feedback

Motion LED feedback:

STATE	DESCRIPTION
● For 45s	Warmup state (state after power ON)
● For 1s	Motion sensed
● For 1s	Motion sensed during test mode

Read mechanism feedback

STATE	DESCRIPTION
● Blink	Blinks X times to indicate the set values for TIME DELAY triggered by READ function.
● Blink	Blinks X times to indicate the set values for LUX triggered by READ function.

IR frame ACK feedback:

STATE	DESCRIPTION
● 3 blinks	Blinks quickly 3 times anytime a message is received from remote
● 3 blinks	Blinks quickly 3 times when the message coming from the remote cannot be taken into account

#### 6.4 WARM UP

When powered on the motion sensor is in warmup state for 45s:  
 Load is ON  
 Green Motion LED is ON  
 AUX functions is active  
 Infrared remote control/trimmer settings are active  
 PIR Sensor is inactive  
 LUX level sensing is inactive

### 7. COVERAGE PERFORMANCE

**Factory setting: "Medium Sensitivity" for a height of 2.5m and a temperature of 20 °C.**

#### 7.1 Radial movement

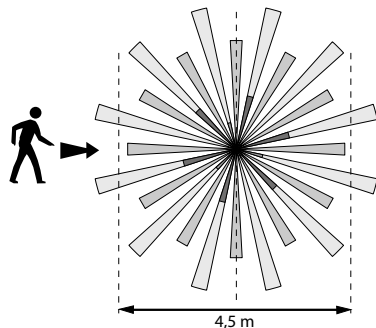
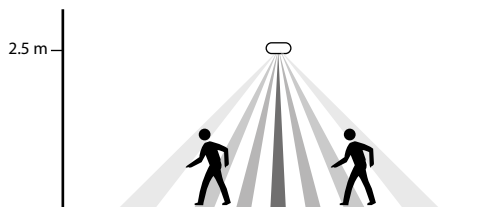

Height (m)	Sensitivity Low	Sensitivity Medium	Sensitivity High
	Ø (m)	Ø (m)	Ø (m)
2.5	4	4.5	5
3.5	4.5	6	7
4	5	6	7.5

### 7. COVERAGE PERFORMANCE (Continued)

#### 7.2 Tangential movement

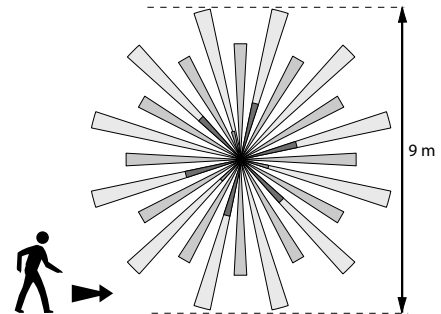
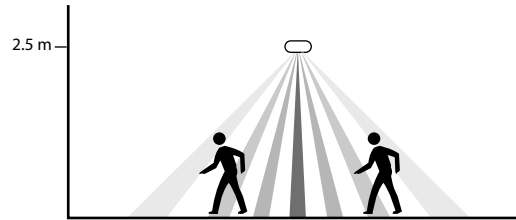

Height (m)	Sensitivity Low	Sensitivity Medium	Sensitivity High
	Ø (m)	Ø (m)	Ø (m)
2.5	7	9	10
3.5	7	9	12
4	7	10	12.5

#### Remark:

For an optimal trigger, the movement must be done perpendicular to the detector. In case direct and frontal approach, the detection of a movement will be harder, and scope will be therefore much lower.

### 8. FONCTIONNEMENT

#### 8.1 More than one sensor and more than one load

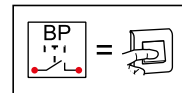

inversion of the state of the loads: < 1s























⊗ L1 OFF ⊗ L2 OFF ⊗ Ln OFF	S1 OFF 	BP < 1s	☀ L1 ON 100% ☀ L2 ON 100% ☀ Ln ON 100%	S1 ON 
☀ L1 ON 100% ☀ L1 ON 100% ☀ Ln ON 100%	S1 ON 	BP < 1s	⊗ L1 OFF ⊗ L2 OFF ⊗ Ln OFF	S1 OFF 

## MINI RECESSED DALI LIGHTING CONTROL SENSOR

### 8. FONCTIONNEMENT (Continued)

#### ■ 8.1 More than one sensor and more than one load (continued)

Lamp dimming:  > 1s

 L1 ON 100%  L2 ON 100%  Ln ON 100%	 S1 ON 	BP  > 1s	 L1 ON 50%  L2 ON 50%  Ln ON 50%	 ON 
 L1 ON 50%  L2 ON 50%  Ln ON 50%	 S1 ON 	BP  > 1s	 L1 ON 100%  L2 ON 100%  Ln ON 100%	 ON 

### 9. MAINTENANCE

Ensure the lens remains clean.

Surface cleaning using a cloth.

Do not use: acetone, tar remover, trichloroethylene.

Resistant to the following products:

- Hexane (EN 60669-1),
- Methylated spirit,
- Soapy water,
- Diluted ammonia
- Bleach diluted to 10%,
- Window cleaning products.

**WARNING:** Conduct preliminary tests before using any other specific cleaning products.

### 10. STANDARDS

LVD: Low Voltage Directive

Directive: 2014/35/EU

Standard: IEC 60669-2-1

EMC: Electromagnetic Compatibility

Directive: 2014/30/EU

Product standards: IEC 60669-2-1

IEC 61000-3-2

ROHS: Restriction of Hazardous substances,

Directive: 2011/65/EU of 08 June 2011 amended by 2015/862 of

31 March 2015 (ROHS 2)

Standard: EN IEC63000