

GREEN-I

STANDARD RECESSED/ SURFACE DALI LIGHTING CONTROL SENSOR

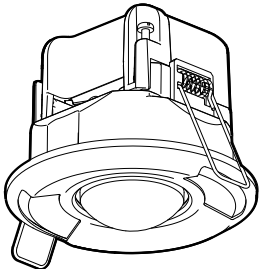

Recessed
GEFL-W-DD (White)
GEFL-B-DD (Black)

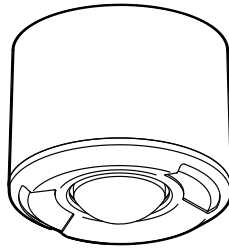

Surface
GESM-W-DD (White)
GESM-B-DD (Black)

CONTENT

1. USE	1
2. TECHNICAL CHARACTERISTICS	1
3. DIMENSIONS	2
4. CONNECTION	2
5. INSTALLATION	3
6. SETTINGS	5
7. COVERAGE PERFORMANCE	7
8. FONCTIONNEMENT	7
9. MAINTENANCE	8
10. STANDARDS	8

1. USE

This device is used to control DALI light source automatically by detecting movement, using infrared (IR) technology. This motion sensor has a 360° detection angle, and when positioned 2.5m above the ground, and a 14m diameter detection area. It is installed on recessed ceiling (GEFL-W-DD/GEFL-B-DD) or surface ceiling (GESM-W-DD/GESM-B-DD). It is quick and easy to set, using potentiometers or an IR remote control (GE-HS).

Detection type: Infrared (PIR)
Mounting type: Ceiling
Time Delay: 10sec to 45min
Light Level Setpoint: 5... 2000lux

2. TECHNICAL CHARACTERISTICS

2.1 Technical data

Voltage: 100-240V ~
Frequency: 50 / 60 Hz
Power consumption: 0.17W
Output: DALI
Cabling: 1x2,5mm²
Flush-mounting diameter: 67 mm
Weight: 89,6 g (GEFL-W-DD/GEFL-B-DD)
120,1 g (GESM-W-DD/GESM-B-DD)
Impact resistance: IK04
Penetration by solid bodies and liquids:
IP41 (GEFL-W-DD/GEFL-B-DD)
IP40 (GESM-W-DD/GESM-B-DD)
Operating temperature: -5°C to +30°C
Storage temperature: -20°C to +70°C

2.2 Features

- 1 DALI output for supplying the bus and controlling lighting
- 1 auxiliary input for overriding lightings using a push button connected to the line.
- 1 sensor (pyroelectric technology) with its lens for sensing movement.
- A daylight sensor measuring the natural and artificial light for driving lightings according to the daylight setpoint.
- An Infrared protocol to configure.
 - Time delay
 - Daylight setpoint
 - Launch test mode
 - PIR Sensitivity

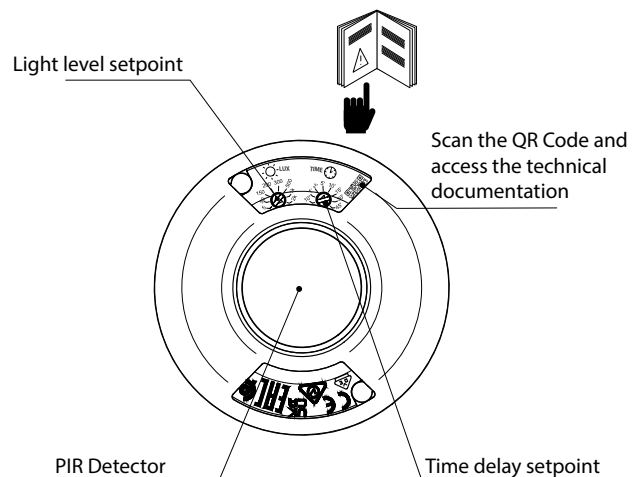
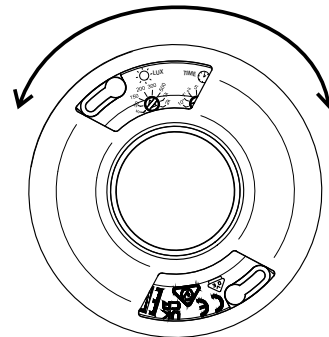
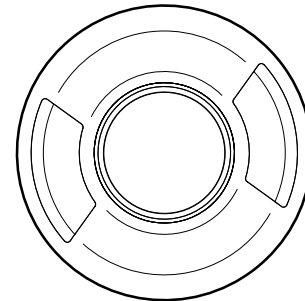

STANDARD RECESSED/ SURFACE DALI LIGHTING CONTROL SENSOR

2. TECHNICAL CHARACTERISTICS (Continued)

■ **2.3 Load**

Output current (guaranteed): 56mA / 16V
 Output current (max): 75mA / 16V

3. DIMENSIONS

■ **3.1 Without surface mount box (Cat. Nos GEFL-W-DD/GEFL-B-DD)**

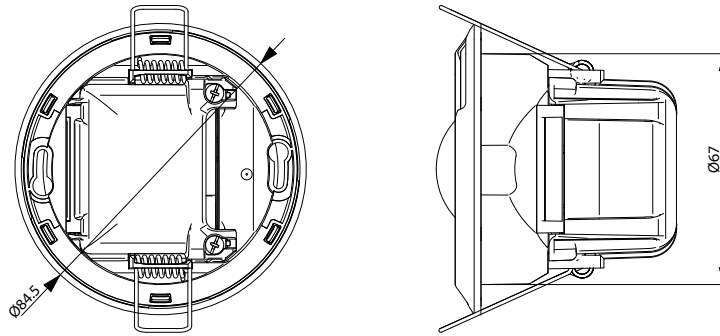

■ **3.2 With surface mount box (Cat. Nos GESM-W-DD/GESM-B-DD)**

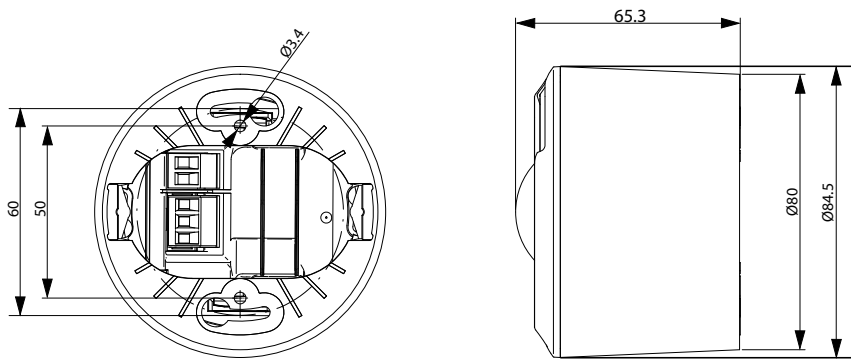

4. CONNECTION

Number of terminals: 3pins+2pins
 Terminal type: pluggable terminal
 Terminal capacity: 1×2.5mm²
 Stripping length: 8 mm

■ **4.1 Wiring with auxiliary control**

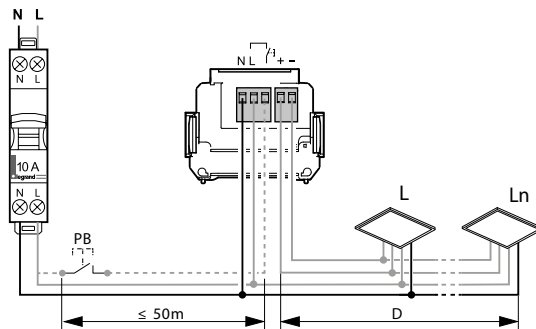

Bus DALI / DALI Bus

D	
≤ 100 m	0.5 mm ²
≤ 150 m	0.75 mm ²
≤ 300 m	1.5 mm ²

STANDARD RECESSED/ SURFACE DALI LIGHTING CONTROL SENSOR

5. INSTALLATION

■ 5.1 Recessed mounting

GEFL-W-DD/GEFL-B-DD

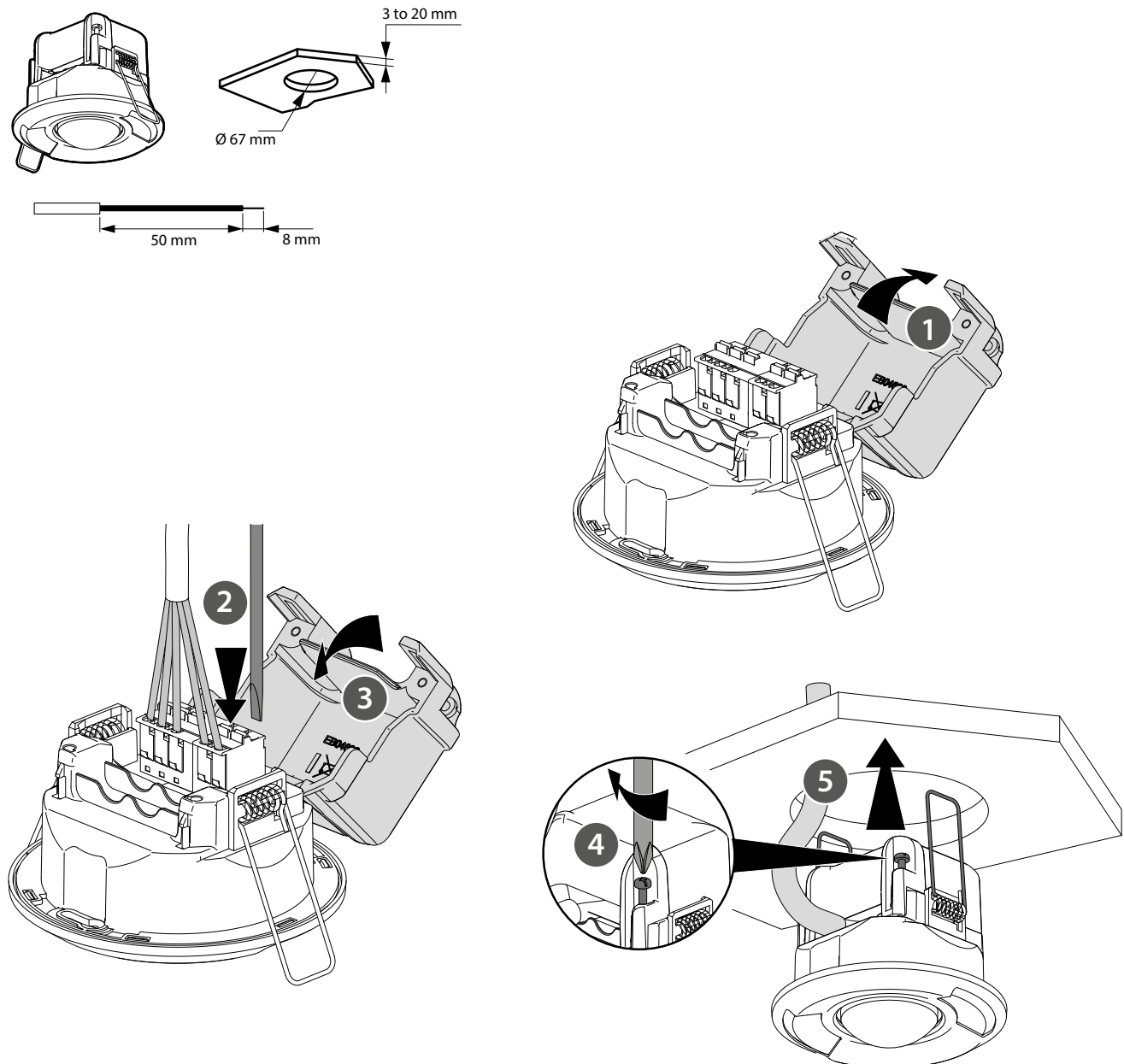

STANDARD RECESSED/ SURFACE DALI LIGHTING CONTROL SENSOR

5. INSTALLATION (Continued)

■ 5.2 Surface mounting

GESM-W-DD/GESM-B-DD

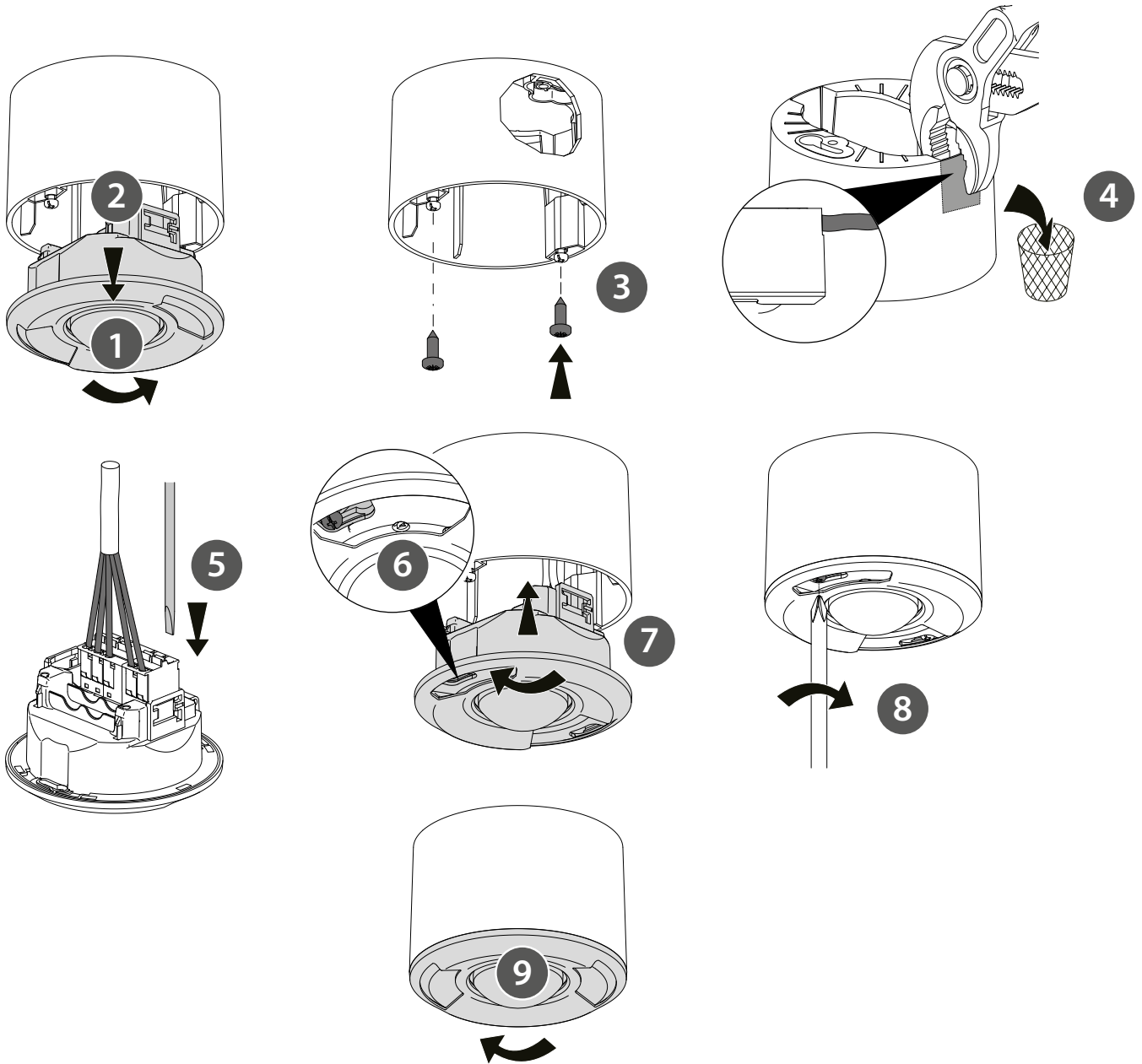

STANDARD RECESSED/ SURFACE DALI LIGHTING CONTROL SENSOR

6. SETTINGS

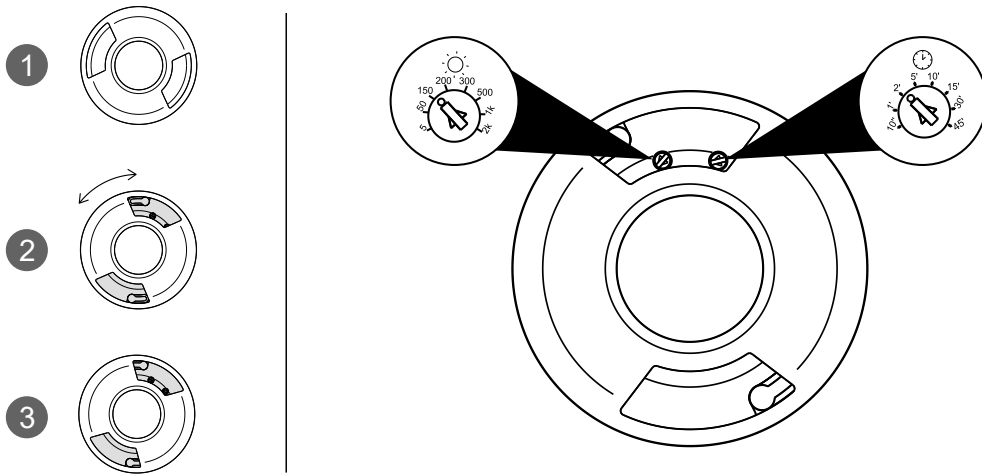



6.1 Setting by Trimmer

The product is set with this trimmer's positions.

Time delay setpoint: Time for which light is switched on following detection.

Light level setpoint: Light level setpoint value below which the light is switched on and above which the light is switched off.

Position	Trimmer daylight 	Trimmer time delay 
1	5 lux (Min)	10 sec
2	50 lux	1 min
3	150 lux	2 min
4	200 lux	5 min
5	300 lux	10 min
6	500 lux	15min
7	1000 lux	30 min
8	2000 lux (Max)	45 min

Factory Settings:

Trimmer daylight: position 8 (max)

Trimmer time delay: position 1 (10sec)

6.2 Setting by Infrared remote control (Cat. No GE-HS)

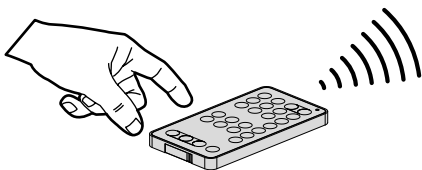
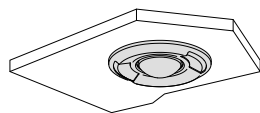

6.2 Setting by Infrared remote control (Continued)

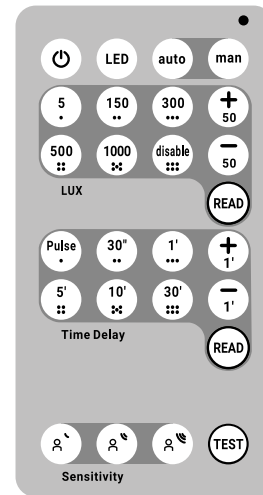

Notes 1: Auto on/Auto off mode:

Automatic switch-on:

- On detection of presence if the natural light level is insufficient.

Automatic switch-off:

- If no presence is detected and at the end of the set time delay

- Or if the natural light level is sufficient

Another detection causes automatic switch-on if there is insufficient light.

Notes 2: Manual on/Auto off mode:

Manual switch-on, automatic switch-off:

- When no presence is detected and at the end of the set time delay. After switch-off, any new detection within a 30 second period triggers an automatic switch-on.

After 30 seconds the device is switched on via a manual switch.

Note 3: Test Mode:

This mode bypass parameters for 10 minutes.

Every detection switch ON the motion LED (in purple) for 1sec and drives the lightings for 5 seconds.

























After these 5 seconds, if no motion is sensed, the lightings turn OFF, else the 5 seconds delay is refreshed (test mode restarts).

The 10 minutes test timer is reset only if remote control test button is pushed again.

STANDARD RECESSED/ SURFACE DALI LIGHTING CONTROL SENSOR

6. SETTINGS (Continued)

■ 6.2 Setting by Infrared remote control (continued)

TYPE	KEY	NAME	DESCRIPTION	Comment
Parameter		Load ON/OFF	Turn ON/OFF the connected loads	After the setting is successful, the purple LED on the product blinks quickly three times.
		Motion LED ON/OFF	Enables or Disables the motion detection LED(green)	
		Auto ON Auto OFF	The load will be switched on and off automatically	
		Manuel ON Auto OFF	Manual switching on by pressing the push button / Automatic switching off at the end of the timer period	
Light level Setpoint		5 LUX	Set light level to 5 LUX	
		150 LUX	Set light level to 150 LUX	
		300 LUX	Set light level to 300 LUX	
		500 LUX	Set light level to 500 LUX	
		1000 LUX	Set light level to 1000 LUX	
		Disable light level Regulation	Light will always be turn on/off no matter light level	
		Read light level	Upon activation the sensor yellow LED will blink «x» times to indicate the set values for LUX	Exemple : the sensor's LED blinks yellow 3 times = light level is set to 300 LUX or the closest value (250 or 350 LUX).
		Increase 50 lux	Increase by 50 LUX the set LUX level (maximum value when pressing + is 2000 LUX)	
		Decrease 50 lux	Decrease by 50 LUX the set LUX level	
	Time delay		Pulse	Activate the pulse function on the sensor
		30 seconds	Set time delay to 30s	
		1 minute	Set time delay to 1min	
		5 minutes	Set time delay to 5min	
		10 minutes	Set time delay to 10min	
		30 minutes	Set time delay to 30min	
		Read time delay	Upon activation the sensor blue LED will blink «x» times to indicate the set values for time delay	Exemple : the sensor's LED blinks blue 4 times = time delay is set to 5minutes or closest value (4 min or 6 min).
		Increase 1 minute	Increase by 1min the set the time delay (maximum value when pressing + is 60 min)	
		Decrease 1 minute	Decrease by 1min the set the time delay	
Sensitivity		PIR sensitivity	1.Low 2.Medium 3.High	Factory settings: medium
Test Mode		Test Mode	Test mode is activated during 10min and the time delay is 5s.	Temporary sets values to : LUX disabled Delay 5s After test period, values return to their original settings and the test can be interrupted by pushing the button once more.

STANDARD RECESSED/ SURFACE DALI LIGHTING CONTROL SENSOR

6. SETTINGS (Continued)

6.3 Pilot lamp feedback

Motion LED feedback:

STATE	DESCRIPTION
● For 45s	Warmup state (state after power ON)
● For 1s	Motion sensed
● For 1s	Motion sensed during test mode

Read mechanism feedback

STATE	DESCRIPTION
● Blink	Blinks X times to indicate the set values for TIME DELAY triggered by READ function.
● Blink	Blinks X times to indicate the set values for LUX triggered by READ function.

IR frame ACK feedback:

STATE	DESCRIPTION
● 3 blinks	Blinks quickly 3 times anytime a message is received from remote
● 3 blinks	Blinks quickly 3 times when the message coming from the remote cannot be taken into account

6.4 WARM UP

When powered on the motion sensor is in warmup state for 45s:
 Green Motion LED is ON
 AUX functions is active
 Infrared remote control/trimmer settings are active
 PIR Sensor is inactive
 LUX level sensing is inactive

7. COVERAGE PERFORMANCE

7.1 Radial movement

Factory setting: "Medium Sensitivity" for a height of 2.5m and a temperature of 20 °C.

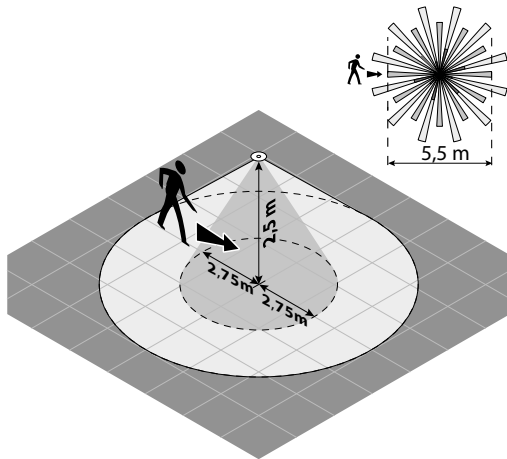

Height (m)	Sensitivity Low	Sensitivity Medium	Sensitivity High
	Ø (m)	Ø (m)	Ø (m)
2.5(*)	5	5.5	6.6
3.5(*)	4.8	5.6	9.4
4	4	6.5	7.5

(*): Test according to the IEC 63180:2020 standard

7. COVERAGE PERFORMANCE (Continued)

7.2 Tangential movement

Factory setting: "Medium Sensitivity" for a height of 2.5m and a temperature of 20 °C.

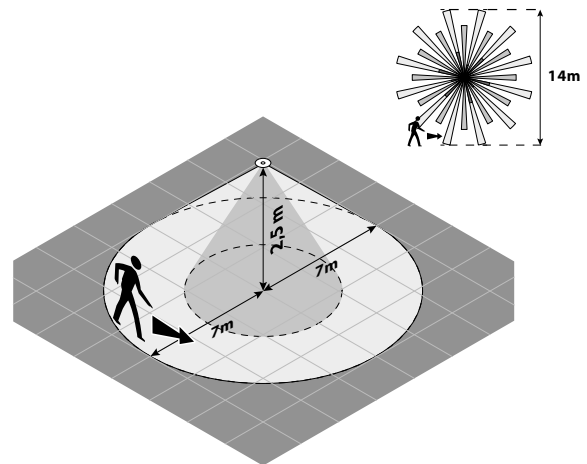

Height (m)	Sensitivity Low	Sensitivity Medium	Sensitivity High
	Ø (m)	Ø (m)	Ø (m)
2.5(*)	10	14	16
3.5(*)	10	16	21
4	9	14	18

(*): according to the IEC 63180:2020 standard

Remark:

For an optimal trigger, the movement must be done perpendicular to the detector. In case direct and frontal approach, the detection of a movement will be harder, and scope will be therefore much lower.

8. FONCTIONNEMENT

8.1 Single sensor and more than one load

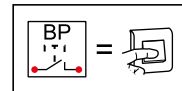

⊗ L OFF	OFF	BP	☀ L ON 100%	ON
⊗ Ln OFF	☀	☀ < 1s	☀ Ln ON 100%	☀
☀ L ON 100%	ON	BP	⊗ L OFF	OFF
☀ Ln ON 100%	☀	☀ < 1s	⊗ Ln OFF	☀

STANDARD RECESSED/ SURFACE DALI LIGHTING CONTROL SENSOR

8. FONCTIONNEMENT (Continued)

8.1 Single sensor and more than one load(continuted)

L1 ON 100%	ON 	BP > 1s	L1 ON 50%	ON
Ln ON 100%			Ln ON 50%	
L1 ON 50%	ON 	BP > 1s	L1 ON 100%	ON
Ln ON 50%			Ln ON 100%	

9. MAINTENANCE

Ensure the lens remains clean.
 Surface cleaning using a cloth.
 Do not use: acetone, tar remover, trichloroethylene.
 Resistant to the following products:

- Hexane (EN 60669-1),
- Methylated spirit,
- Soapy water,
- Diluted ammonia
- Bleach diluted to 10%,
- Window cleaning products.

WARNING: Conduct preliminary tests before using any other specific cleaning products.

10. STANDARDS

LVD: Low Voltage Directive
 Directive: 2014/35/EU
 Standard: IEC 60669-2-1

EMC: Electromagnetic Compatibility
 Directive: 2014/30/EU
 Product standards: IEC 60669-2-1
 IEC 61000-3-2

ROHS: Restriction of Hazardous substances,
 Directive:2011/65/EU of 08 June 2011 amended by 2015/862 of 31 March 2015(ROHS 2)
 Standard: EN IEC63000