

Motion SENSOR PIR 360°

Cat. No(s): 0 487 37



CONTENTS	PAGE
1. Use	1
2. Technical features	1
3. Overall dimensions	1
4. Connection	2
5. Installation	2
6. Setting	2
6.1 Setting time (switch-off delay)	2
6.2 Twilight setting (light sensitivity)	2
7. Performance	2
8. Standards	2

1. USE

This device enables a light source to be controlled automatically by detecting presence in the monitoring area.

Using passive infrared technology, this motion sensor has a 360° detection angle and, when positioned 3 m above the ground, 6 m diameter detection area.

Quick and easy to set, using potentiometers.

The light level threshold can vary from 3 to ☀ and the time delay from 10 seconds to 15 minutes.

Mounting: Flush-mounted.

Indoor.

2. TECHNICAL FEATURES

- Voltage: 220 - 240 V~
- Voltage type: AC
- Frequency: 50/60 Hz
- Wiring: 2 x 1.5 mm²
- Maximum Input cable diameter: 11 mm
- Type of terminal: screw
- Cable nature for connection: Flexible
- Built-in diameter: 62 mm

2. TECHNICAL FEATURES (continued)

- Penetration by solid and liquid matter: IP20
- Protection class: IK 02
- Operating / setting temperature: -20°C to +40°C
- Storage temperature: -5°C to +45°C
- Material quality: Thermoplastic
- Surface finishing: Glossy
- Colour: White

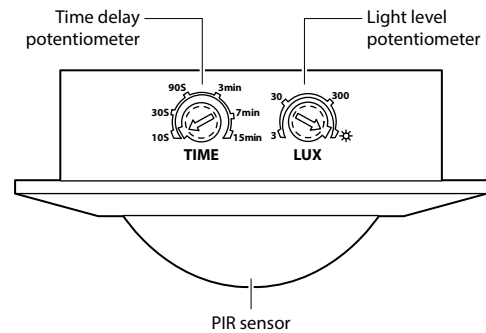

	①	②	③
230 V~	1200 W	5.2 A	300 W
		1.3 A	300 W
			1.3 A

- 1 - Halogen lamp
- 2 - Compact fluorescent lamp with integrated electronic ballast
- 3 - LED lamp

3. OVERALL DIMENSIONS

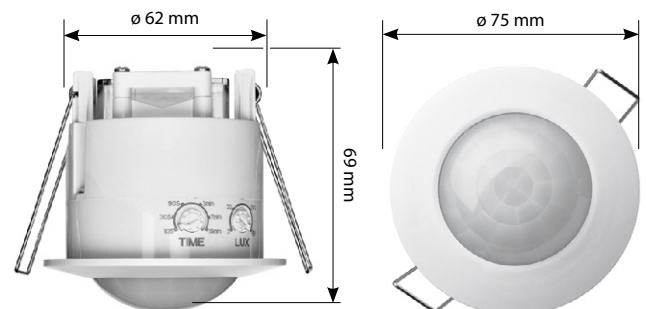

4. CONNECTION

Wiring: 2 x 1.5 mm²
Type of terminal: screw

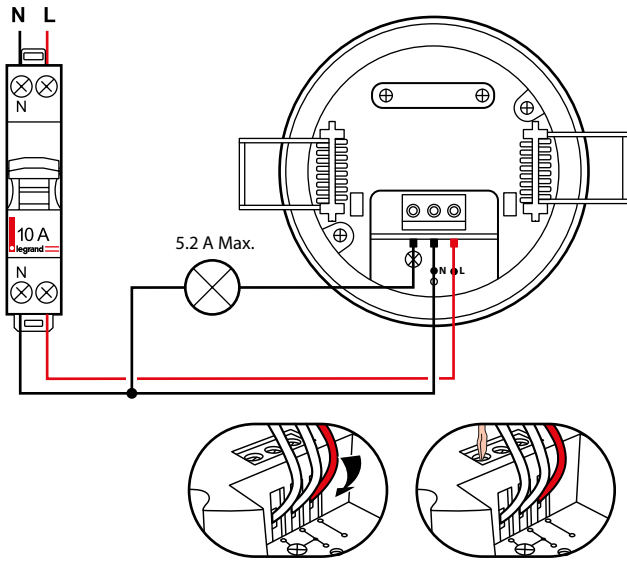

5. INSTALLATION

Install the sensor in a suitable place where its performance will not be affected by direct hot air flow (e.g. from a heater), direct sunshine or other disturbing factors.

1. Select a suitable location, preferably across the monitored area, up to 3 m in height.
2. Switch off the main power supply, connect the wires according to the diagram and then connect the sensor to the junction box.
3. Use the switch to set the desired parameters of the sensor.

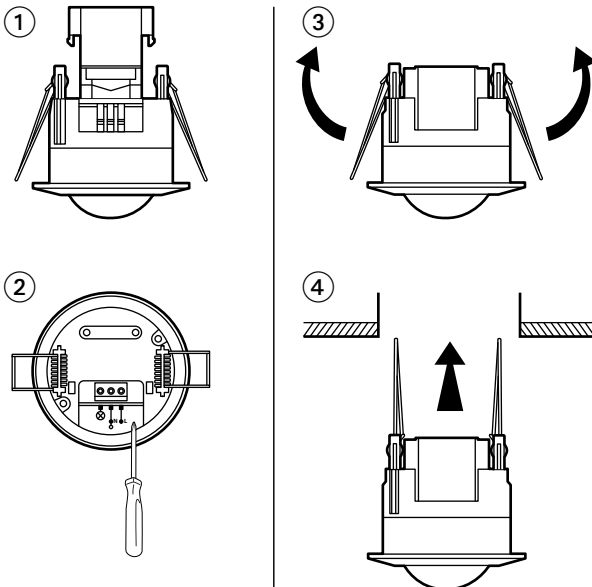
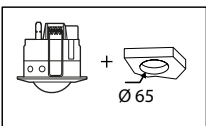

6. SETTING

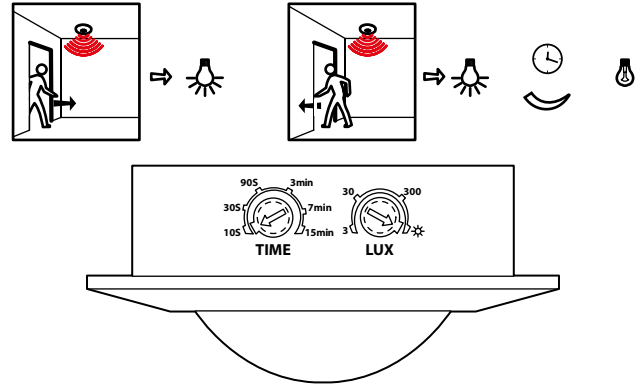

6.1 Setting time (switch-off delay)

Install the sensor in a suitable place where its performance will not be affected by direct hot air flow (e.g. from a heater), direct sunshine or other disturbing factors.

1. Select a suitable location, preferably across the monitored area, up to 3 m in height.
2. Switch off the main power supply, connect the wires according to the diagram and then connect the sensor to the junction box.
3. Use the switch to set the desired parameters of the sensor.

6.2 Twilight setting (light sensitivity)

You can adjust the desired light sensitivity continuously within the range of approx. 3 to ☀

7. PERFORMANCE

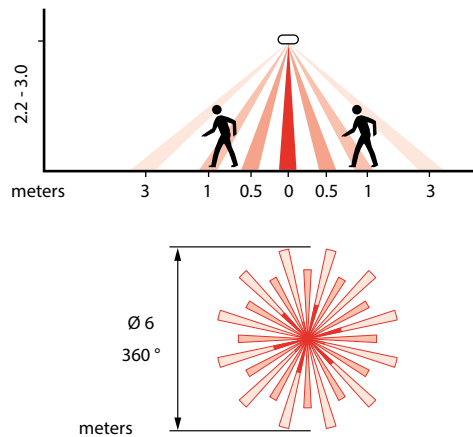

8. STANDARDS

- Directive: CE
- Installation standards: NFC 15-100
- Product standards: IEC 60669-2-1
- Environmental standards:
 - European Directive 2002/96/EC: WEEE (Waste Electrical and Electronic Equipment).
 - European Directive 2002/95/EC: RoHS (Restriction of Hazardous Substances).