

MS double sided busbar

low and medium power 63/100/160 A

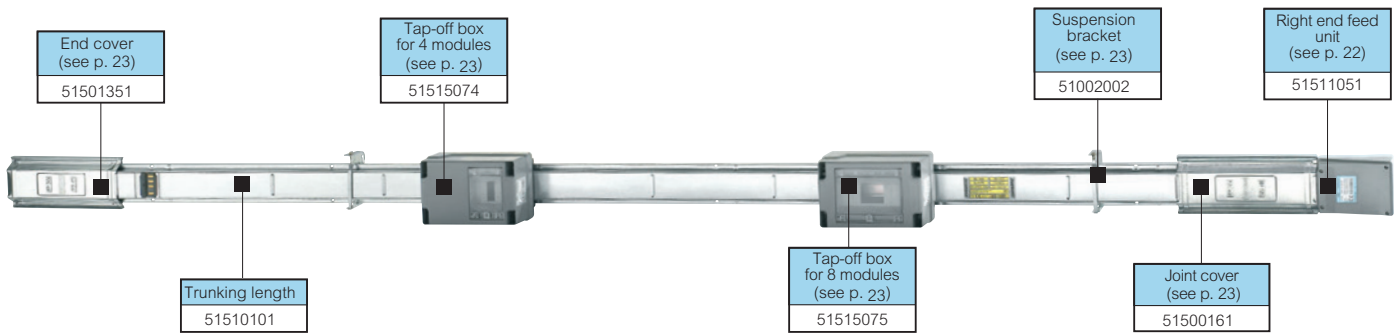

Dimensions and technical information p. 24
 Technical data p. 27

Conforms to BS EN 61439-6. Casing manufactured from Senzimir quality galvanised steel suitable for use as a protective earth IP 40 as standard, increasing to IP 55 with use of appropriate accessories

Pack	Cat. Nos.	63 A trunking lengths																					
		Tap-off outlets are spaced every 1.0 m on both sides and are fitted with shutters to prevent accidental contact with live parts Expansion joints are not required																					
		Standard lengths																					
		<table border="1"> <thead> <tr> <th>Length (m)</th> <th>Outlet points</th> <th>Weight (kg)</th> </tr> </thead> <tbody> <tr> <td>3</td> <td>3 + 3</td> <td>7.890</td> </tr> <tr> <td>2</td> <td>2 + 2</td> <td>5.260</td> </tr> <tr> <td>1.5</td> <td>1 + 1</td> <td>3.945</td> </tr> <tr> <td>1</td> <td>1 + 1</td> <td>2.630</td> </tr> <tr> <td>< 1.5</td> <td>–</td> <td>–</td> </tr> <tr> <td>> 1.5</td> <td>–</td> <td>–</td> </tr> </tbody> </table>	Length (m)	Outlet points	Weight (kg)	3	3 + 3	7.890	2	2 + 2	5.260	1.5	1 + 1	3.945	1	1 + 1	2.630	< 1.5	–	–	> 1.5	–	–
Length (m)	Outlet points	Weight (kg)																					
3	3 + 3	7.890																					
2	2 + 2	5.260																					
1.5	1 + 1	3.945																					
1	1 + 1	2.630																					
< 1.5	–	–																					
> 1.5	–	–																					
1	51530101																						
1	51530116																						
1	51530115																						
1	51530114																						
1	51530112																						
1	51530113																						

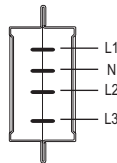

Pack	Cat. Nos.	160 A trunking lengths																					
		Standard lengths																					
		<table border="1"> <thead> <tr> <th>Length (m)</th> <th>Outlet points</th> <th>Weight (kg)</th> </tr> </thead> <tbody> <tr> <td>3</td> <td>3 + 3</td> <td>9.290</td> </tr> <tr> <td>2</td> <td>2 + 2</td> <td>6.190</td> </tr> <tr> <td>1.5</td> <td>1 + 1</td> <td>4.645</td> </tr> <tr> <td>1</td> <td>1 + 1</td> <td>3.100</td> </tr> <tr> <td>< 1.5</td> <td>–</td> <td>–</td> </tr> <tr> <td>> 1.5</td> <td>–</td> <td>–</td> </tr> </tbody> </table>	Length (m)	Outlet points	Weight (kg)	3	3 + 3	9.290	2	2 + 2	6.190	1.5	1 + 1	4.645	1	1 + 1	3.100	< 1.5	–	–	> 1.5	–	–
Length (m)	Outlet points	Weight (kg)																					
3	3 + 3	9.290																					
2	2 + 2	6.190																					
1.5	1 + 1	4.645																					
1	1 + 1	3.100																					
< 1.5	–	–																					
> 1.5	–	–																					
1	51520101																						
1	51520116																						
1	51520115																						
1	51520114																						
1	51520112																						
1	51520113																						
		Fire barrier kit E120																					
1	515EFB01	External fire barrier kit for use with 63 A, 100 A and 160 A trunking lengths																					
1	515IFB01	Internal fire barrier kit for use with 63 A, 100 A and 160 A trunking lengths																					

Pack	Cat. Nos.	100 A trunking lengths																					
		Standard lengths																					
		<table border="1"> <thead> <tr> <th>Length (m)</th> <th>Outlet points</th> <th>Weight (kg)</th> </tr> </thead> <tbody> <tr> <td>3</td> <td>3 + 3</td> <td>7.890</td> </tr> <tr> <td>2</td> <td>2 + 2</td> <td>5.260</td> </tr> <tr> <td>1.5</td> <td>1 + 1</td> <td>3.945</td> </tr> <tr> <td>1</td> <td>1 + 1</td> <td>2.630</td> </tr> <tr> <td>< 1.5</td> <td>–</td> <td>–</td> </tr> <tr> <td>> 1.5</td> <td>–</td> <td>–</td> </tr> </tbody> </table>	Length (m)	Outlet points	Weight (kg)	3	3 + 3	7.890	2	2 + 2	5.260	1.5	1 + 1	3.945	1	1 + 1	2.630	< 1.5	–	–	> 1.5	–	–
Length (m)	Outlet points	Weight (kg)																					
3	3 + 3	7.890																					
2	2 + 2	5.260																					
1.5	1 + 1	3.945																					
1	1 + 1	2.630																					
< 1.5	–	–																					
> 1.5	–	–																					
1	51510101																						
1	51510116																						
1	51510115																						
1	51510114																						
1	51510112																						
1	51510113																						