

Incara™ Disq'In - German standard

technical characteristics

■ Dimensions (mm)

View from above

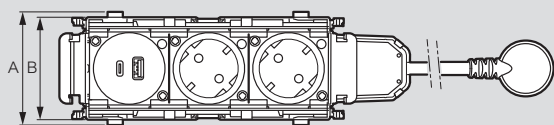

Cat.Nos	A	B
6 547 46/47/48/49/50/51	74	67

Side views

2-gang

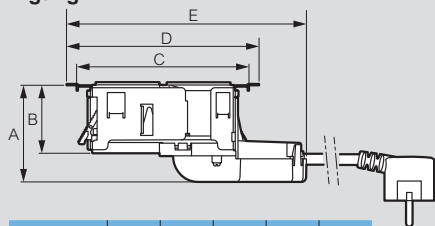

Cat.Nos	A	B	C	D	E
6 547 46/49	71	50	126.8	141.6	176.4

3-gang

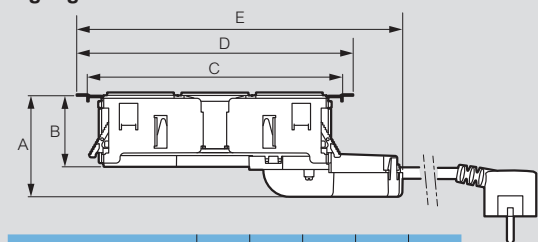

Cat.Nos	A	B	C	D	E
6 547 47/50	71	50	179.7	194.5	229.4

4-gang

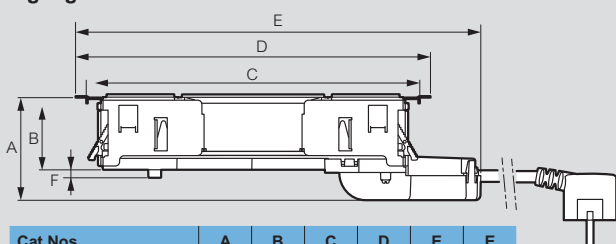

Cat.Nos	A	B	C	D	E	F
6 547 48/51	71	50	231	245.8	280.6	55

View from above - finishing plates

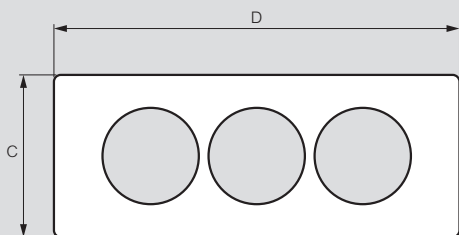

Cat.Nos	C	D
6 547 55/56/57	80	148
6 547 59/60/61	80	200
6 547 63/64/65	80	252

■ Dimensions (mm) (continued)



Cat.Nos	A	B
6 547 55/56/57	10.4	2.2
6 547 59/60/61	10.4	2.2
6 547 63/64/65	10.4	2.2

■ Positioning

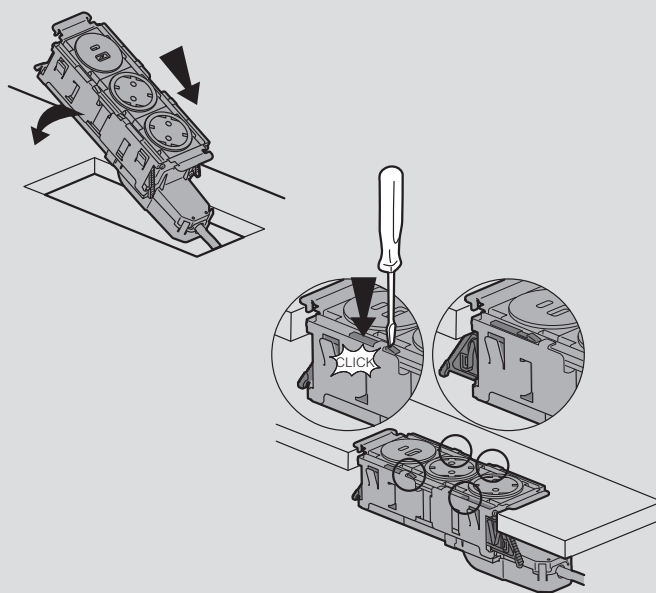

■ Drilling dimensions

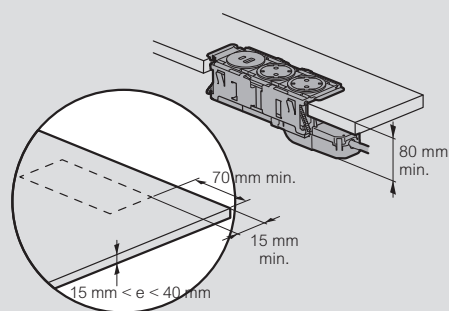

■ Cut-out for corners

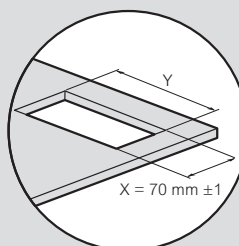

Cat.Nos	Y ± 1 mm
6 547 46/49	129.5
6 547 47/50	181.5
6 547 48/51	233.5

Note: For other cut-outs: see the product data sheet available online