

DPX³ 250 HP

technical characteristics

Dimensions

Fixed version, front terminals

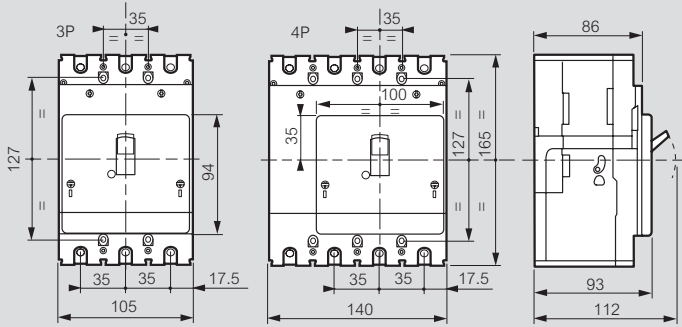

Fixed version with electronic earth leakage module

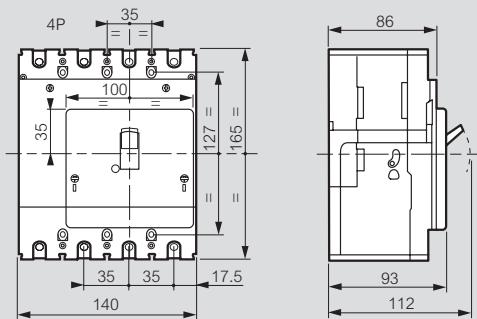

Fixed version with rear terminals Cat.Nos 4 238 91/92

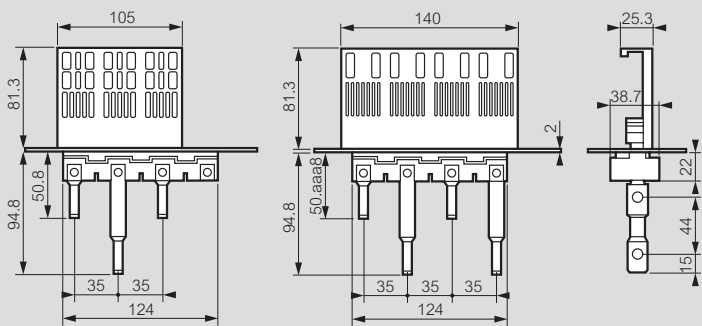

Spreaders Cat.Nos 4 238 23/24

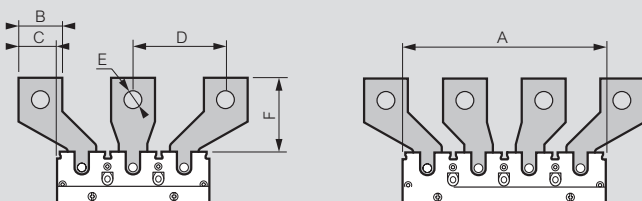

	A	B	C	D	E	F
3P	105	30	27	63.5	13	50
4P	140	30	27	63.5	13	50

Plug-in version front terminals

Front view

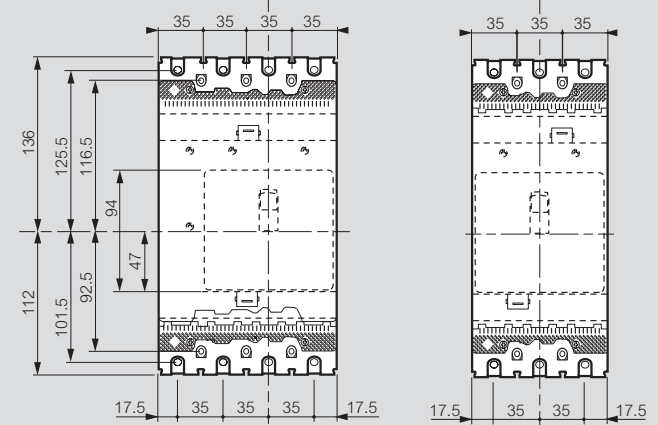

Side view with faceplate

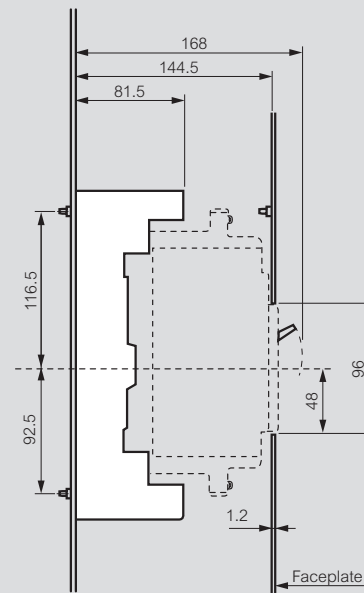

Front view with faceplate

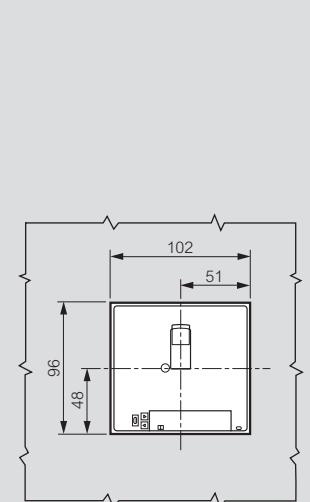

Plug-in base with rear terminals Cat.Nos 4 238 21/22

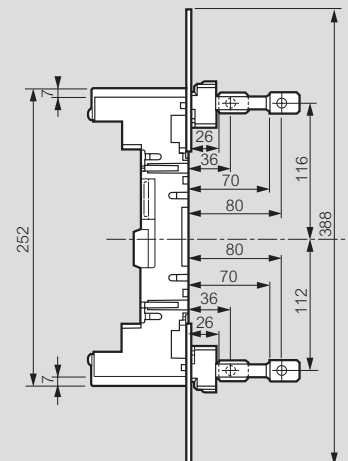

More dimensions for DPX³ 250 HP
see technical sheets