

DPX³ 160 equipment and mounting accessories



4 210 55



4 210 71



4 210 68

Pack	Cat.Nos	Connection accessories
1	4 210 26	High capacity cage terminals For Cu/Al cables, 1 x 120 mm ² for flexible cables and 1 x 150 mm ² for rigid cable and 18 mm bars
1	4 210 27	Set of 3 terminals Set of 4 terminals
1	4 210 93	Cage terminals For Cu cables, 1 x 70 mm ² for flexible cables and 1 x 95 mm ² for rigid cables and 14 mm bars
1	4 210 94	Set of 3 terminals Set of 4 terminals
1	4 210 70	Insulated shields (phase barriers) Set of 36 insulated shields
1	4 210 28	Screw terminals for bars connection For copper bars
1	4 210 29	Set of 3 terminals Set of 4 terminals
1	4 210 32	Spreaders For incoming bars or cable lugs
1	4 210 33	Set of 3 spreaders for DPX ³ 160 3P Set of 4 spreaders for DPX ³ 160 4P
1	4 210 54	Sealable terminal shields For front terminals
1	4 210 55	For DPX ³ 160 3P For DPX ³ 160 3P
1	4 210 71	Fixing plates For fixing DPX ³ 160 on \perp rail or on plate
1	4 210 73	For DPX ³ 160 3P/4P without earth leakage module
1	4 210 68	For DPX ³ 160 3P/4P with earth leakage module For DPX ³ 160 3P/4P with side mounting motor operator

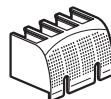

DPX³ 160 connection

Connection

Direct connection

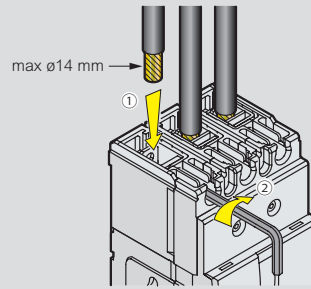

Flexible	
1,5	→ 70 mm ²
#16	→ #2/0 AWG
or	
Solid	
1,5	→ 95 mm ²
#16	→ #4/0 AWG

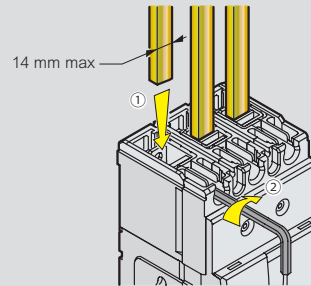
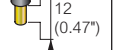

Spreaders

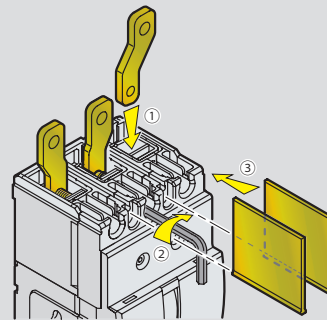

Sealable terminal shield

