

DMX³ 2500 et DMX³-I 2500

dimensions

Version fixe - taille 1

Cotes d'encombrement

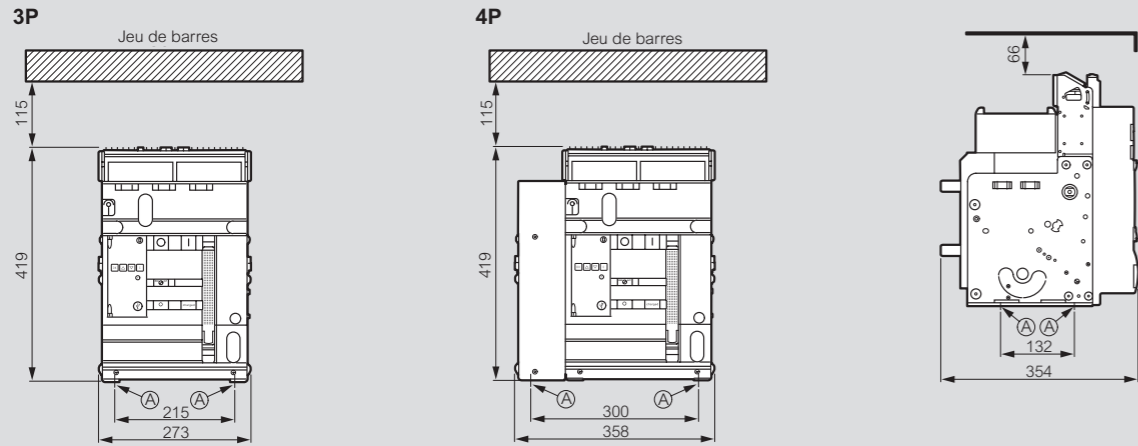

A = points de fixation sur la platine de montage

Principe de raccordement

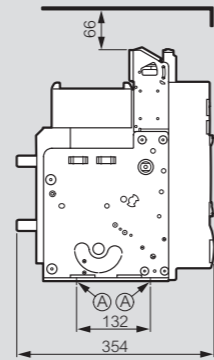
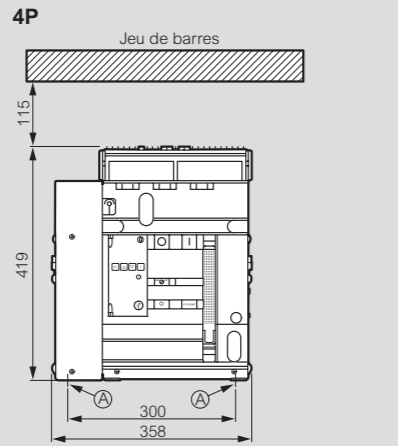
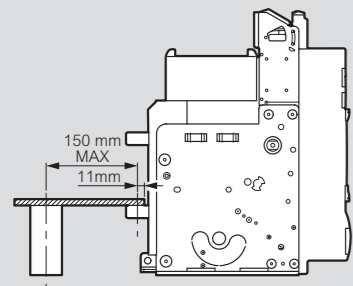

Prises arrière pour raccordement vertical

Réf. 0 288 82/83

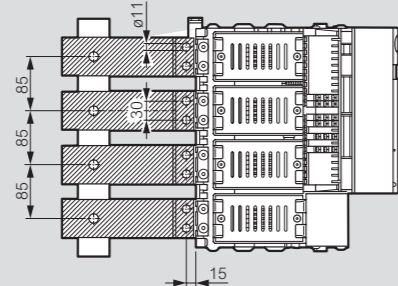
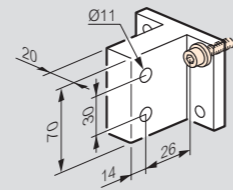

Prises arrière pour raccordement horizontal

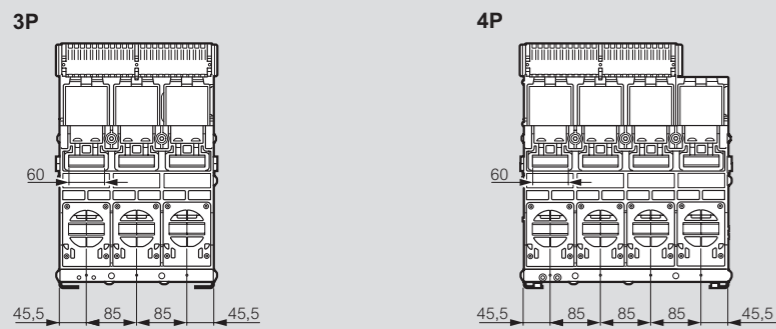

Épanouisseurs pour raccordement à plat

Réf. 0 288 86/87

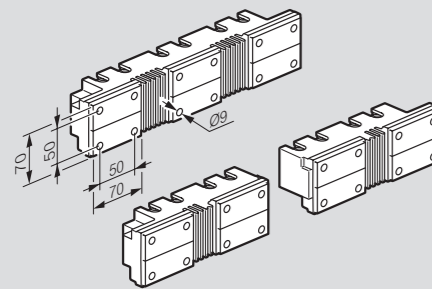

Épanouisseurs pour raccordement vertical

Réf. 0 288 88/89

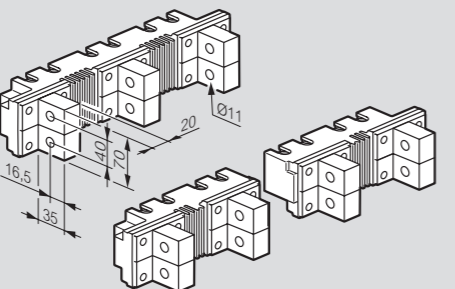

Épanouisseurs pour raccordement horizontal

Réf. 0 288 90/91

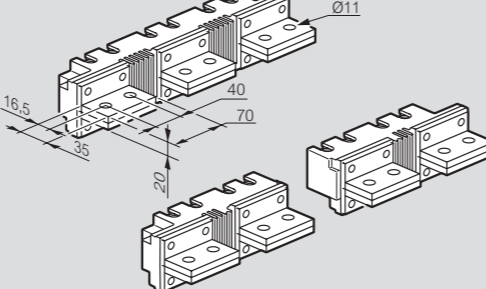

Version débrochable - taille 1

Cotes d'encombrement

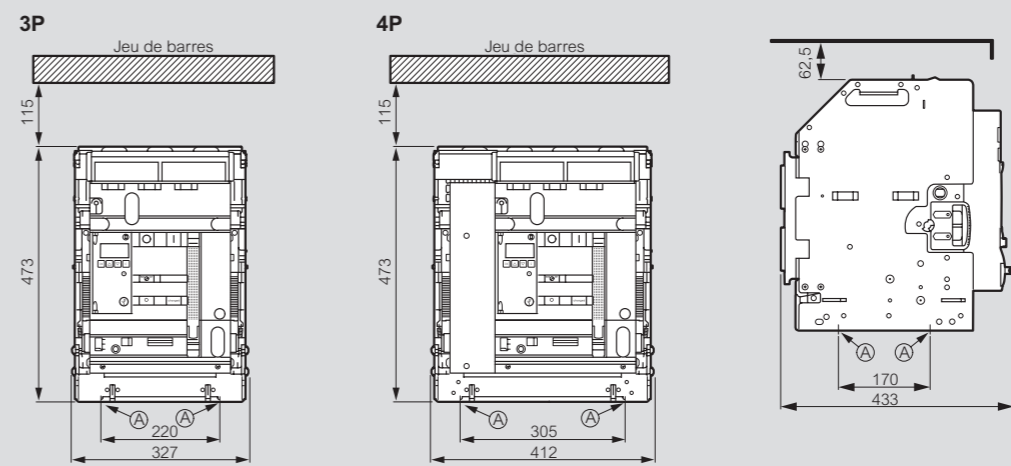

A = points de fixation sur la platine de montage

Prises arrière pour raccordement à plat

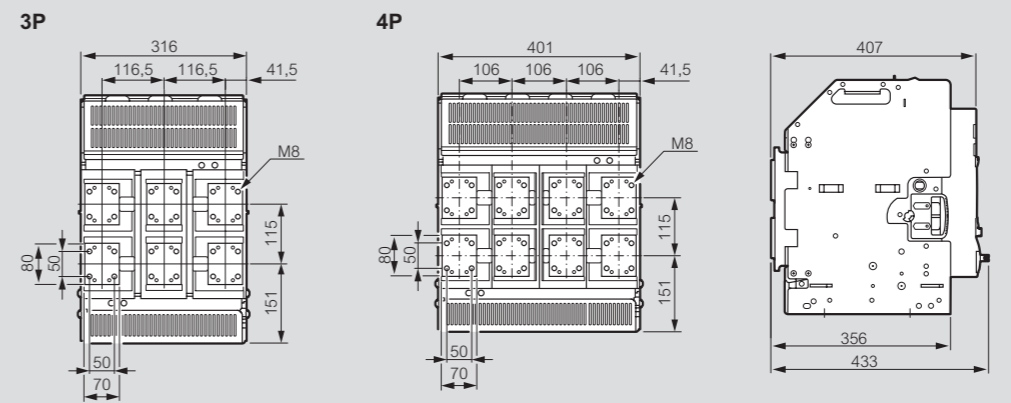

Prises arrière pour raccordement horizontal - Réf. 0 288 96/97

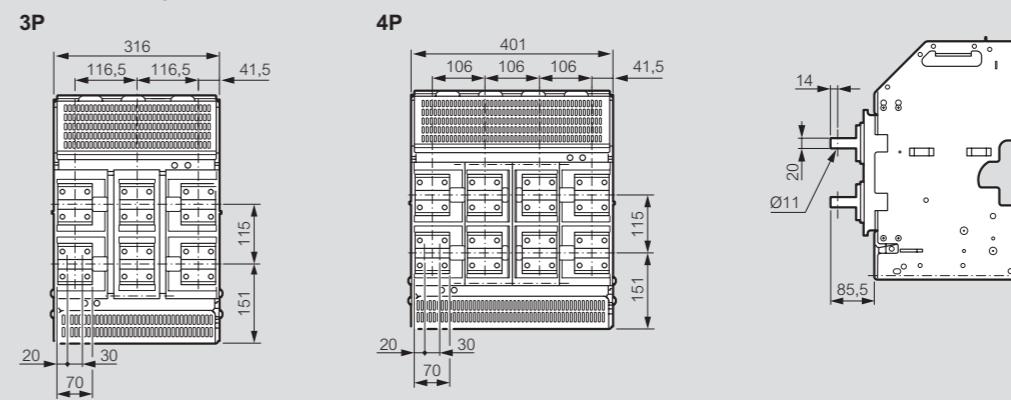

Prises arrière pour raccordement vertical - Réf. 0 288 96/97

