

WORKSHOP SPECIFICATIONS

AIR CIRCUIT BREAKERS

DMX-SP 2500 and DMX-SP 4000



THE GLOBAL SPECIALIST IN ELECTRICAL AND DIGITAL BUILDING INFRASTRUCTURES

 **legrand**[®]

Air circuit breakers are a key component of the main distribution board.

Legrand DMX-SP circuit breaker range, available from 630 A to 4000 A, provide protection and control at the supply end of low voltage installations.

Their efficiency not only ensures the safety of people and property, as well as continuity of service, it also promotes energy management through their advanced protection units.

DMX-SP range of circuit breakers and isolating switches offer numerous accessory options, protection units, high performance levels and a rugged construction, all of which make them ideally suited to meet the needs of safety and energy management in installations.

LEGAL INFORMATION

Presentation pictures do not always include Personal Protective Equipment (PPE), but this is a legal and regulatory obligation that must be scrupulously respected.

In accordance with its continuous improvement policy, Legrand reserves the right to change the specifications and illustrations without notice.

All illustrations, descriptions and technical information included in this document are provided as indications and cannot be held against Legrand..

SUMMARY

Safety instructions.....	4
PRESENTATION	
DMX-SP ordering and delivery status	6
DMX-SP ranges	10
Front view	12
ACCESSORIES	
Electrical accessories.....	16
Mechanical accessories.....	78
Power and earth connection accessories.....	122
INSTALLATION	
DMX-SP cabinet installation.....	136
Protection units.....	138
PCS software and application.....	142
Firts commissioning.....	144
MAINTENANCE	
Maintenance	150
Spare parts and accessories.....	154

SAFETY

instructions

General information

- Use only the products and accessories recommended by the Legrand Group in the catalogue, instructions, technical data sheets and all other documents provided by Legrand (hereinafter referred to as «the Documentation») in compliance with the installation rules.
- Improper installation and/or use may result in the risk of arcing in the enclosure, overheating or fire. The enclosures must be used under normal conditions, they must not be subjected to Voltage / Current / Temperature values other than those specified in the Documentation.
- Legrand declines all responsibility for any modification or repair of the equipment making up the enclosure that is not authorized by the Legrand Group, as well as any failure to comply with the rules and recommendations specified by Legrand in the Documentation. In addition, in the cases mentioned above, the warranty granted by Legrand will not be applicable.
- It is necessary to check that the characteristics of the products are appropriate for their environment and use during maintenance operations, and to refer to the Documentation. If you have any questions or require clarification, please contact Legrand Group.
- The installation, use and maintenance of the enclosures and their components must be carried out by qualified, trained and authorized personnel, in accordance with the regulations in force in each country.



RISK OF ELECTRIC SHOCK, BURNS AND EXPLOSION.

- People working on the installation must have the appropriate electrical authorizations for the work to be carried out.
- Wear the PPE (Personal Protective Equipment) necessary to work on live products.
- Respect the safety rules related to electrical work.
- Improper electrical and mechanical use of equipment can be dangerous and may result in personal injury or damage to property.
- Depending on the maintenance operations to be carried out, partial or total power cuts of the enclosure concerned should be planned before any work.
- When performing operations that involve access to the inside of the enclosure, be aware of the risk of burns before touching any products or metal parts.
- Before turning the power back on, make sure that there are no foreign bodies and that all physical protections have been put back in place (e.g.: screens, covers, shields).

Any failure to strictly apply the procedures and to respect these recommendations, could lead to serious risk of accident, endangering people and property (in particular, without limitation, risk of burns, electric shocks, etc.).



The rules and recommendations in this document are based on our knowledge of the typical conditions of use of our products in the fields of application usually encountered. However, it is always the customer's responsibility to verify and validate that Legrand products are suitable for its installation and use.

The customer must ensure proper installation, maintenance and operation of the equipment to avoid any risk of injury to personnel or damage to property in the event of product failure, especially for applications that require a very high level of safety (e.g., those in which the failure of a component may endanger human life or health).

The rules for storage, handling, installation and maintenance and the appropriate precautions and warnings must be strictly observed and applied.

DMX-SP

ORDERING AND DELIVERY STATUS

A DMX³ circuit breaker cannot be ordered without a protection unit because it has to be programmed according to the circuit breaker and the options needed.

With the software XLPro³ Tables, it is possible to generate an order form into Word[®] format. For more details about the purchase order of DMX-SP, **contact your Legrand interlocutor**. Most electrical and mechanical accessories can be ordered and mounted at the product delivery. For accessories and options necessarily mounted in factories, refer to the table on the next page.

Order ACB DMX ³		Rate for : 2021-10																									
Order n° :		Customer code :																									
Please send this form to your usual commercial/sales contact																											
Construction site informations :																											
Price offer n° :		Date :																									
Site:		Building name :																									
Panel : New panel 1		Building type :																									
Sales representative:		Building address :																									
Manager :																											
Name :		Address :																									
Phone number/Email :																											
Wholesaler		Delivery (if different address)																									
Name :		Company name :																									
Address :		Name :																									
		Address :																									
		Tel. n° / Email :																									
900185 : ACB DMX ³ factory assembled																											
<table border="1"> <thead> <tr> <th>Manufacturer</th> <th>Description</th> <th>Reference</th> <th>Quantity</th> </tr> </thead> <tbody> <tr> <td>Legrand</td> <td>MCCB DMX-SP 4000 50kA 4P 4000A Fixed</td> <td>670273</td> <td>1</td> </tr> <tr> <td>Legrand</td> <td>DMX³ protection unit MP2 10</td> <td>028304</td> <td>1</td> </tr> <tr> <td>Legrand</td> <td>Shunt trip 220-240V A.C./D.C.</td> <td>028851</td> <td>1</td> </tr> <tr> <td>Legrand</td> <td>Undervoltage release 220-240V A.C./D.C.</td> <td>028858</td> <td>1</td> </tr> <tr> <td></td> <td></td> <td></td> <td></td> </tr> </tbody> </table>				Manufacturer	Description	Reference	Quantity	Legrand	MCCB DMX-SP 4000 50kA 4P 4000A Fixed	670273	1	Legrand	DMX ³ protection unit MP2 10	028304	1	Legrand	Shunt trip 220-240V A.C./D.C.	028851	1	Legrand	Undervoltage release 220-240V A.C./D.C.	028858	1				
Manufacturer	Description	Reference	Quantity																								
Legrand	MCCB DMX-SP 4000 50kA 4P 4000A Fixed	670273	1																								
Legrand	DMX ³ protection unit MP2 10	028304	1																								
Legrand	Shunt trip 220-240V A.C./D.C.	028851	1																								
Legrand	Undervoltage release 220-240V A.C./D.C.	028858	1																								
Select 1 language package for the protection unit:																											
English / Italian / Français	English / French	English / Russian	English / Spanish / Portuguese																								
			English / Chinese																								
Quantity of ACB DMX ³ identical : 1																											
Total value :																											

DMX-SP 2500

Depending on the ordered accessories, the following table mentions if they are delivered mounted or not. Depending on the assembly centers and/or the markets, the factory setups of the DMX-SP 2500 can vary.

ACCESSORIES		STATE OF ASSEMBLY	
Cat.Nos	DESCRIPTION	FACTORY ASSEMBLED	DETAILS
0 288 82 83/84/85/86/87/ 88/89/90/96/97 et 6 696 18/19	Rear terminals	NO	They are delivered with the DMX-SP 2500
0 288 20 21/22/23/24	Motor operator	YES	This accessory is fixed inside the DMX-SP 2500 and is connected to the MOT terminal.
0 281 26 to 0 281 40	Tripping unit and coil	YES	This accessory is fixed inside the DMX-SP 2500 and is connected to the UVR/ST/CC terminal.
6 696 00/ 01/02/03	Insulation shields	NO	They are delivered with the DMX-SP 2500
0 283 00/ 01/02/03	Protection unit	YES	It is factory assembled and configured with the factory settings (see the protection unit guide).
6 696 20	External neutral	Partially	The circuit breaker must be factory configured in order to protect an external neutral. A Rogowski coil is delivered with the circuit breaker and must be connected to the protection unit terminal.
4 149 40	Communication Interface (RS485)	YES	The circuit breaker must be factory configured to integrate the communication option.
4 149 45	External power supply	NO	This accessory is not integrated to the circuit breaker. It is fixed on a modular rail.
0 281 73	Inserted/test/drawn-out position signalling contact	NO	It is delivered with the DMX-SP 2500. It is not delivered «mounted» because its connexion requires the disassembly of the circuit breaker (or switch).
0 281 74	Ready to close and spring charged signalling contact	YES	It is fixed inside the DMX-SP 2500 and it is connected to the terminals SC and RC.
0 281 75	Module of 6 additional auxiliary contacts	YES	It is fixed inside the DMX-SP 2500 and it is connected to the terminals OC1/2/3/4/5/6
0 281 76	Module of 4 additional auxiliary contacts	YES	It is fixed inside the DMX-SP 2500 and it is connected to the terminals OC1/2/3/4
0 281 91 + 4 238 80/ 81/82/83	Key locking in «open» position	YES	It is fixed inside the DMX-SP 2500.
0 281 84	Door locking	NO	It is delivered with the DMX-SP 2500.
6 696 08	Inserted/test/drawn-out position lock button	NO	It is delivered with the DMX-SP 2500. Its installation requires the disassembly of the circuit breaker (or switch).
0 281 88	Mechanical counter	YES	It is fixed inside the DMX-SP 2500.
0 281 89	Rating mis-insertion device	YES	It is fixed inside the DMX-SP 2500 but inside the base.
0 281 90	Mechanical interlock	NO	It is fixed inside the DMX-SP 2500 and outside the base.
0 288 62/63	Time-lag module	NO	It is not integrated to the circuit breaker (or switch). It is fixed on a modular rail.
0 289 17/18 et 0 289 20 to 0 289 25	Interlocking cables	NO	They are delivered with the DMX-SP 2500.

DMX-SP ORDERING AND DELIVERY STATE

DMX-SP 4000

Depending on the ordered accessories, the following table mentions if they are delivered mounted or not. Depending on the assembly centers and/or the markets, the factory setups of the DMX-SP 4000 can vary.

ACCESSORIES		STATE OF ASSEMBLY	
Cat.Nos	DESCRIPTION	FACTORY ASSEMBLED	DETAILS
0 283 04/ 05/06/07	Protection unit	YES	Protection units are factory assembled et configured with the factory settings (see the protection unit guide). The batteries and the sealing kit are delivered but not mounted in a separated box.
4 149 40	Communication interface (RS485)	YES	The circuit breaker must be factory configured to integrate the communication option.
4 149 45	External power supply	NO	It is not integrated to the circuit breaker. It is fixed on a modular rail.
0 281 98	External neutral	Partially	The circuit breaker must be factory configured in order to protect an external neutral. A Rogowski coil is delivered with the circuit breaker and must be connected to the protection unit terminal.
0 288 13	Inserted/test/drawn-out position signalling contact	NO	It is delivered with the DMX-SP 4000. It is not delivered «mounted» because its connexion requires the disassembly of the circuit breaker (or switch).
0 288 14	Ready to close and spring charged signalling contact	YES	It is fixed inside the DMX-SP 4000 and it is connected to the terminals SC and RC.
0 288 15	Additional auxiliary contact	YES	It is fixed inside the DMX-SP 4000 and it is connected to the terminals OC3/4/5/6/7/8/9/10
0 288 16	Signalling contact of auxiliaries status	YES	It is fixed inside the DMX-SP 4000, on the corresponding coils and is connected to the terminal C UVR/ C CC/C ST.
0 288 20	Door locking	NO	After purchase order, this accessory is delivered « not mounted » with the DMX-SP 4000.
0 288 21	Padlocks in the «open» position	YES	It is fixed inside the DMX-SP 4000.
0 288 23	Mechanical counter	YES	It is fixed inside the DMX-SP 4000.
0 288 25	Rating mis-insertion device	YES	It is fixed under the DMX-SP 4000 and inside its base.
0 288 26	Padlocks in the «drawnout» position	NO	After ordering, this accessory is delivered « not mounted » with the DMX-SP 4000.
0 288 28 + 4 238 80/ 81/82/83	Key locking in the «open» position	YES	It is fixed inside the DMX-SP 4000.
0 281 94 + 4 238 80/83	Key locking in the «inserted/ test/drawn-out» position	Partially	These accessories are mounted on the bracket. This set is delivered «not mounted» inside the DMX-SP 4000.
0 288 34/35/ 36/37/38/40	Motor operator	YES	It is fixed inside the DMX-SP 4000, and it is connected to the MOT terminal.
0 288 41/ 42/43/44/45/ 48/49/50/51/52/ 55/56/57/58/59	Tripping unit and coil	YES	These accessories are mounted inside the DMX-SP 4000, and they are connected to the UVR/CC/ST terminal.
0 288 62/63	Time-lag module	NO	It is not integrated to the circuit breaker. It is fixed on a modular rail.
0 288 79	Carrying handle	NO	After ordering, this accessory is delivered « not mounted » with the DMX-SP 4000.
0 288 94/95 6 696 14/15	Rear terminals	NO	After ordering, this accessory is delivered « not mounted » with the DMX-SP 4000.
0 288 18/19 0 288 98/99	Insulation shields	Partially	The insulation shields are delivered fixed on the DMX-SP 4000. The shields are delivered with the DMX-SP 4000.
0 288 65	Interlocking cables	Partially	Most of the accessories are mounted on the DMX-SP. Only one piece, identifying the type of reverser (A/B/C/D) is delivered «not mounted».
0 289 17/18/20/ 21/22/23/24/25	Interlocking cables	NO	After ordering, this accessory is delivered (not mounted) with the DMX-SP 4000.

STORAGE

- Store the circuit breaker in a cool place, away from dust and any corrosive environment.
- Do not handle 2 DMX-SP on top of each other, and do not overlap more than 2 circuit breakers on the floor.
- Place the pallets on a stable place.
- All DMX-SP are delivered in a wood case and fixed on pallets with 4 M10 bolts.

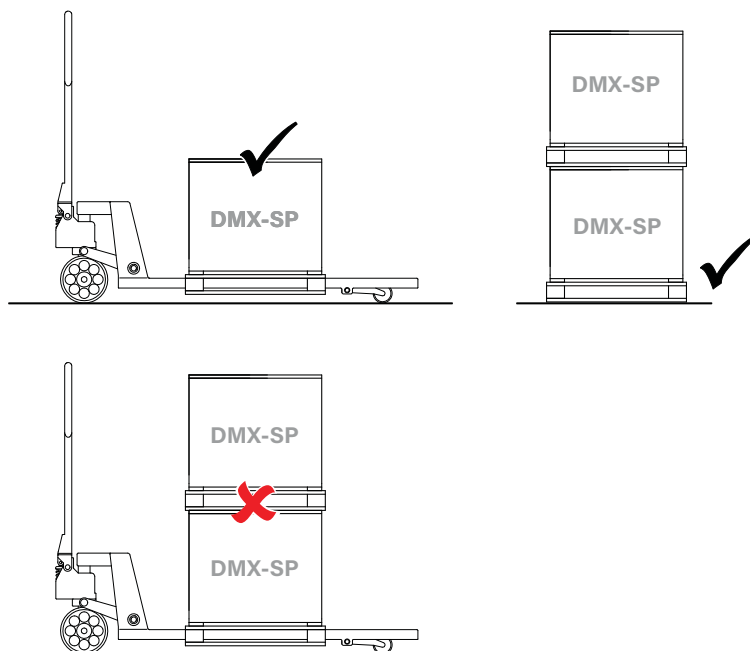

HANDLING AND TRANSPORTATION

- For Draw-out versions, the lifting operation is done in 2 times : first the fixed part (the DMX-SP) then the mobile part (the base) but verify if that the main contacts are open (product in «OFF» position) and that the loading springs are discharged.
- To facilitate the transportation, hooking and lifting handles are incorporated to the DMX-SP 2500 (if there is a base for Draw-out version, it will have handles on it as well). For DMX-SP 4000, lifting handles Cat.Nos 0 288 79 are available as accessories. If there is a base for the Draw-out version, holes are expected to install an adapted lifting device.
- The DMX³ 1600 (fixed and Draw-out versions) can be transported by 2 persons as well (according their capacities and the type of product : from 19kg to 54kg for the DMX-SP 2500 and from 53kg to 93kg for the DMX-SP 4000).

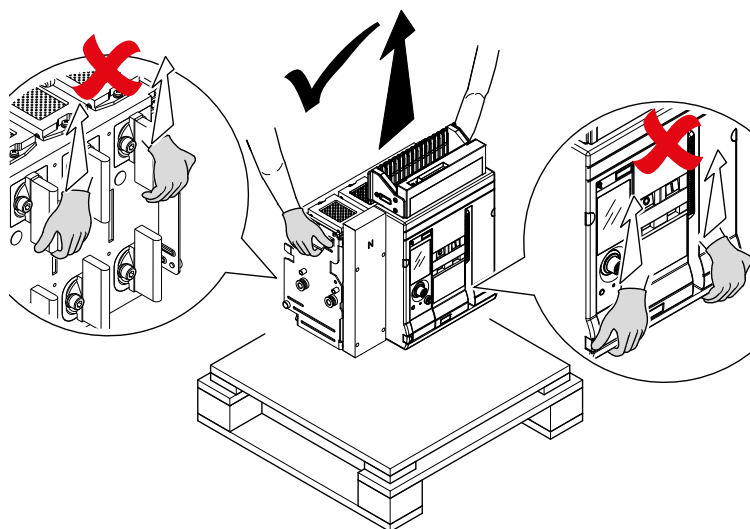

- !** It is forbidden to lift the DMX-SP by the front face and/or the back terminals.
For the Draw-out versions, it is forbidden to lift the base/DMX-SP set at the same time. It is a heavy product, be careful to prevent risks of injury to personnel and/or damage to property.

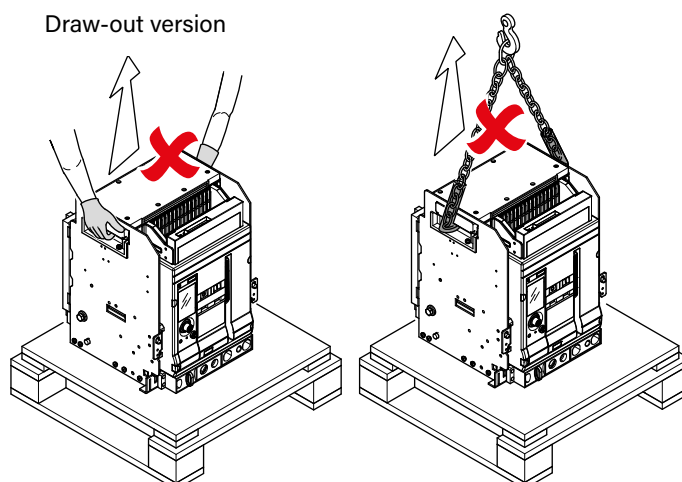

DMX-SP

RANGE

Presentation of the offer

Icu (415~)		42 kA				50 kA				65 kA			
		Fixed		Drawn-out		Fixed		Drawn-out		Fixed		Drawn-out	
In (A)		3P	4P	3P	4P	3P	4P	3P	4P	3P	4P	3P	4P
DMX-SP 2500	630	6 702 00	6 702 07	6 702 30	6 702 37	6 702 14	6 702 21	6 702 44	6 702 51	-	-	-	-
	800	6 702 01	6 702 08	6 702 31	6 702 38	6 702 15	6 702 22	6 702 45	6 702 52	-	-	-	-
	1000	6 702 02	6 702 09	6 702 32	6 702 39	6 702 16	6 702 23	6 702 46	6 702 53	-	-	-	-
	1250	6 702 03	6 702 10	6 702 33	6 702 40	6 702 17	6 702 24	6 702 47	6 702 54	-	-	-	-
	1600	6 702 04	6 702 11	6 702 34	6 702 41	6 702 18	6 702 25	6 702 48	6 702 55	-	-	-	-
	2000	6 702 05	6 702 12	6 702 35	6 702 42	6 702 19	6 702 26	6 702 49	6 702 56	-	-	-	-
	2500	6 702 06	6 702 13	6 702 36	6 702 43	6 702 20	6 702 27	6 702 50	6 702 57	-	-	-	-
	BASE	-	-	6 696 10	6 696 11	-	-	6 696 10	6 696 11	-	-	-	-
DMX-SP 4000	3200	-	-	-	-	6 702 60	6 702 62	6 702 70	6 702 72	6 702 65	6 702 67	6 702 75	6 702 77
	4000	-	-	-	-	6 702 61	6 702 63	6 702 71	6 702 73	6 702 66	6 702 68	6 702 76	6 702 78
	BASE	-	-	-	-	-	-	6 696 12	6 696 13	-	-	6 696 12	6 696 13

		Fixed		Drawn-out	
In (A)		3P	4P	3P	4P
DMX-SP-I 2500	630	6 702 80	6 702 85	6 702 90	6 702 95
	800	6 702 81	6 702 86	6 702 91	6 702 96
	1000	6 702 82	6 702 87	6 702 92	6 702 97
	1250	6 702 83	6 702 88	6 702 93	6 702 98
	1600	6 702 84	6 702 89	6 702 94	6 702 99
	2000	6 702 28	6 702 58	6 702 64	6 702 74
	2500	6 702 29	6 702 59	6 702 69	6 702 79
	BASE	-	-	6 696 10	6 696 11
DMX-SP-I 4000	3200	6 696 80	6 696 82	6 696 84	6 696 86
	4000	6 696 81	6 696 83	6 696 85	6 696 87
	BASE	-	-	6 696 12	6 696 13

DMX-SP air circuit breakers are available in 3 breaking capacities (42 kA, 50 kA for the 2500 size and 50 kA, 65 kA for the 4000 size), 9 rated currents (from 630 A to 2500 A for the 2500 size and from 3200 A to 4000 A for the 4000 size), and in fixed and Draw-out versions.

- DMX-SP 42 kA
- DMX-SP 50 kA
- DMX-SP 65 kA

In	Rated current
Icw (1 s)	Short time withstand current
Ics	Rated short-circuit service breaking capacity
Uimp	Rated impulse withstand voltage
Ui	Rated insulation voltage
IEC/EN 60947-2	Normative compliance
Cat. B	Category of use

- Example of a label with a breaking capacity of 50 kA

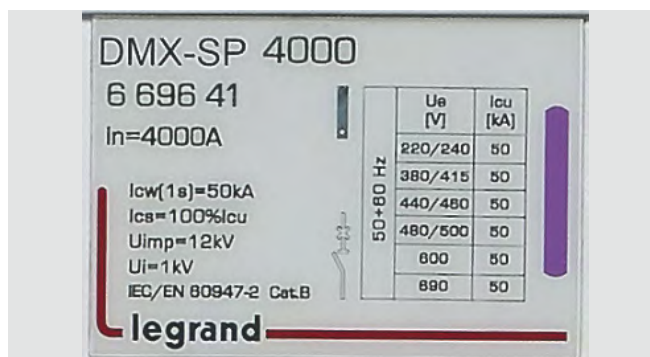
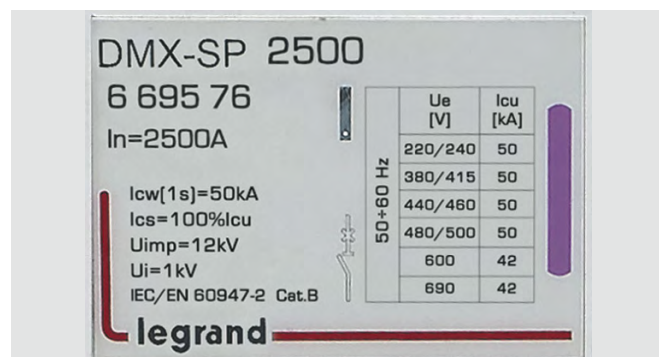

Breaking capacities & rated currents									
	630 A	800 A	1000 A	1250 A	1600 A	2000 A	2500 A	3200 A	4000 A
DMX-SP	42 kA fixed and drawn-out							-	-
	50 kA fixed and drawn-out								
	-	-	-	-	-	-	-	65 kA fixed and drawn-out	
DMX-SP-I	Fixed and drawn-out								

DMX-SP 2500

FRONT VIEW

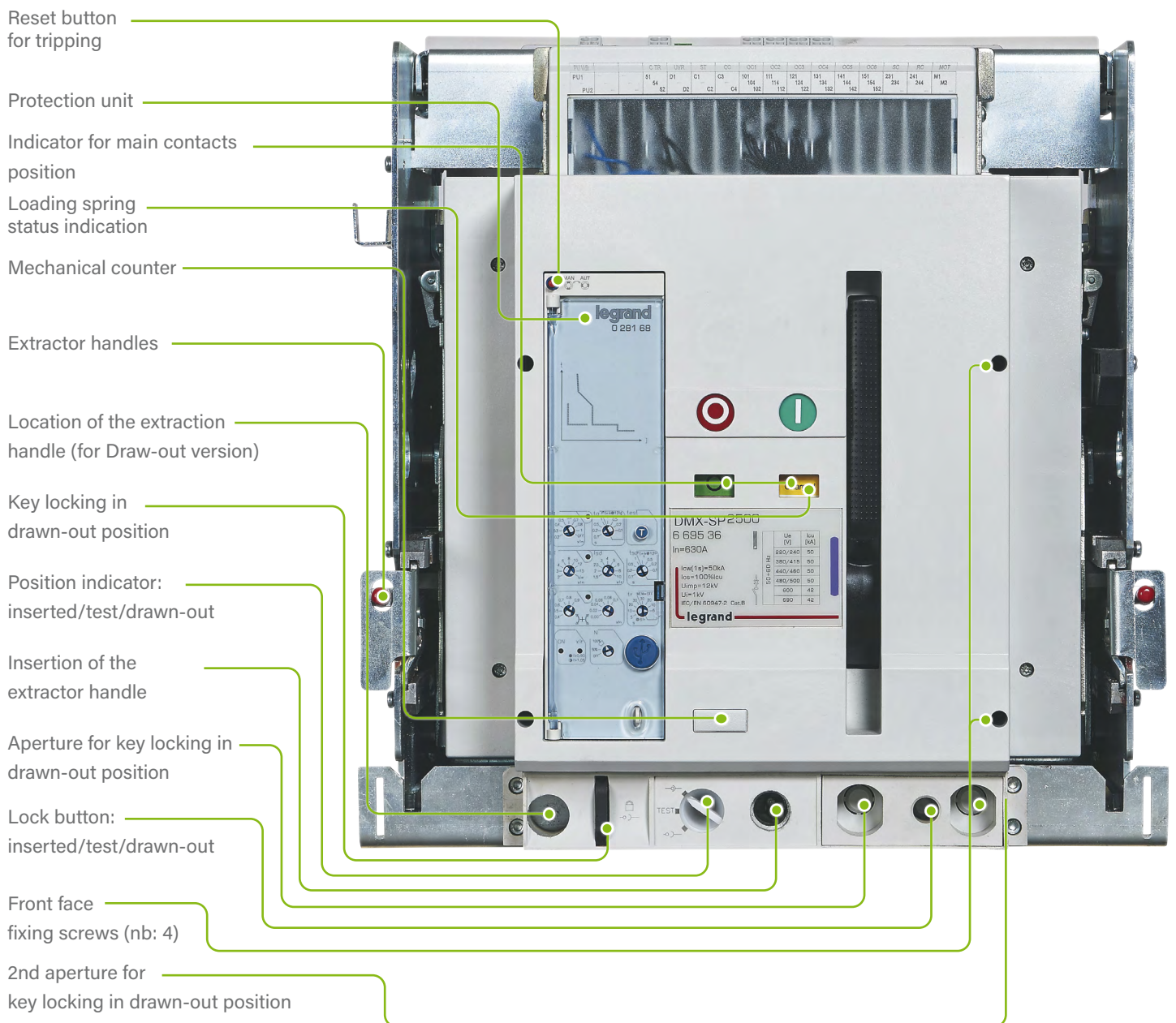

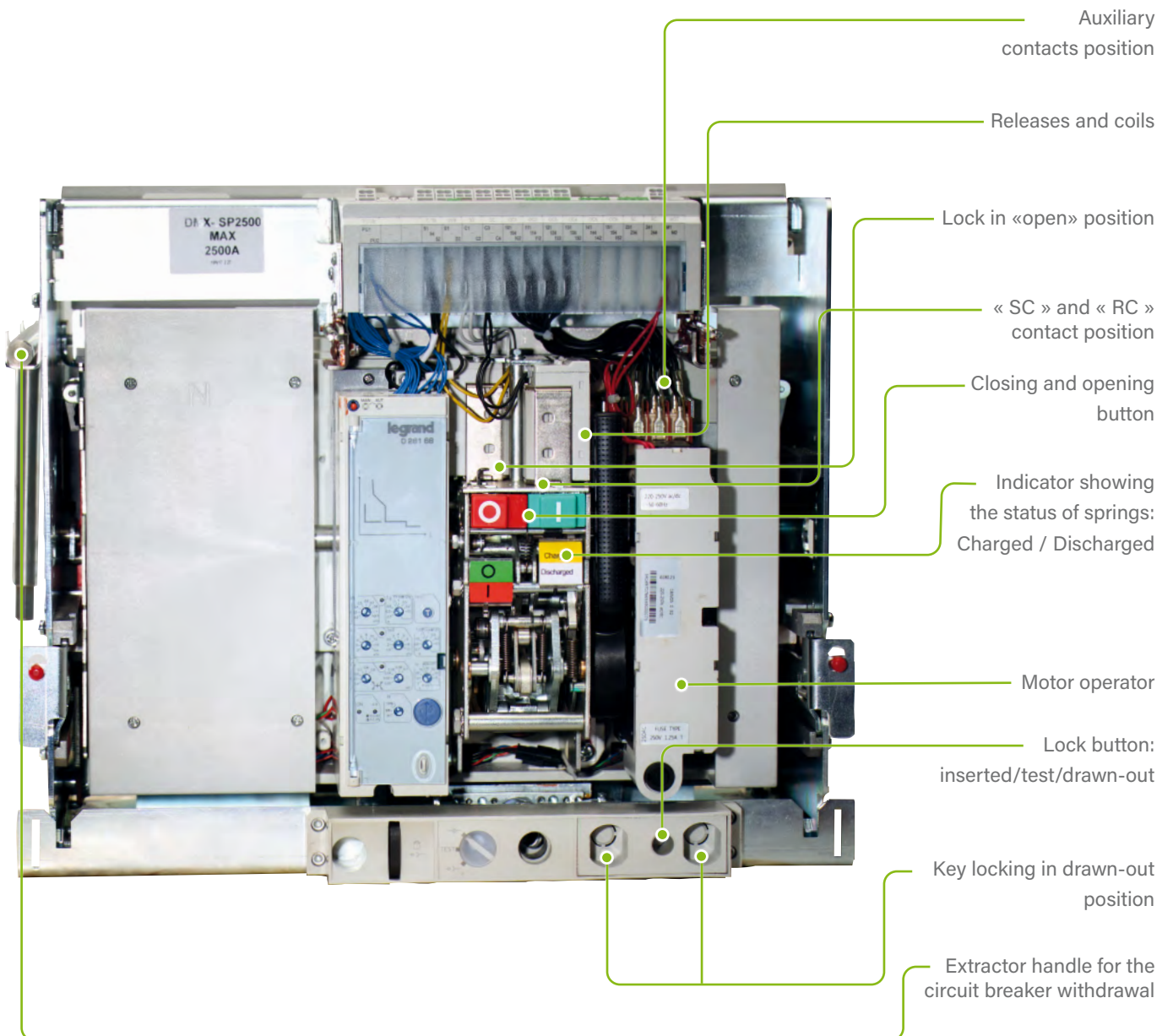

DMX-SP 4000

FRONT VIEW

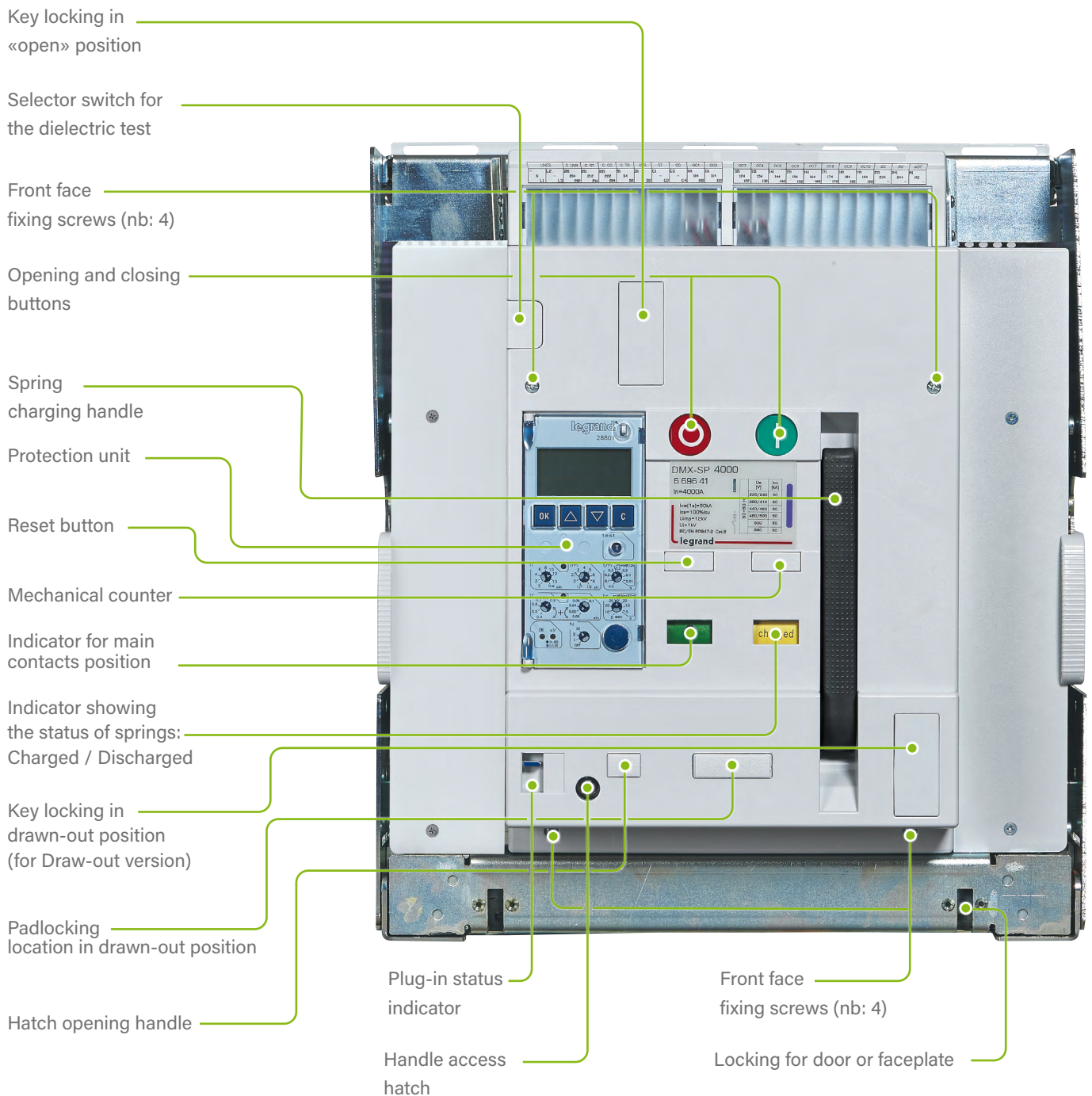

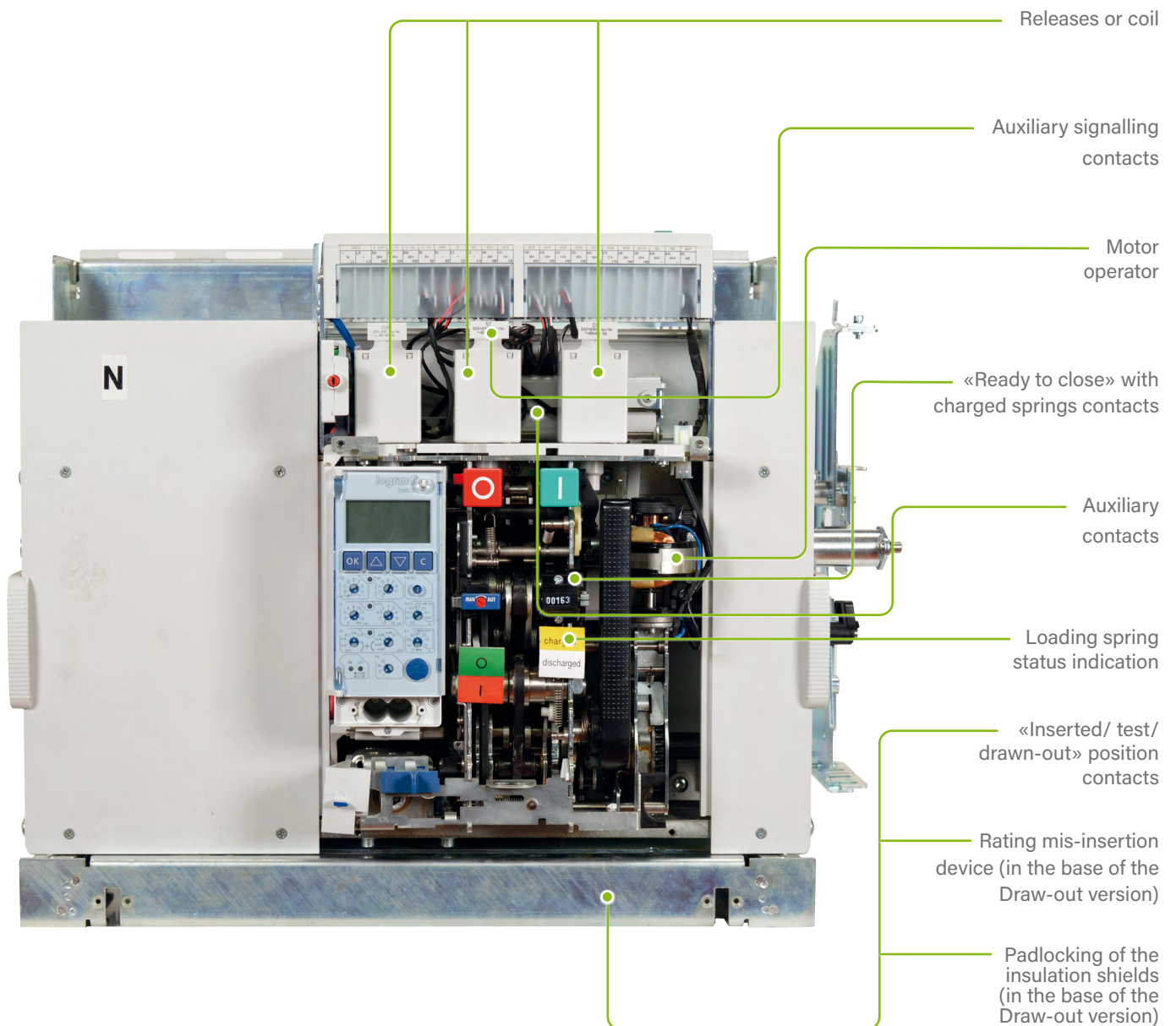

ELECTRICAL ACCESSORIES

DMX-SP 2500

1. Shunt trip (Cat.No 0 281 31/32/33/34/35).
2. Undervoltage release (Cat.No 0 281 36/37/38/39/40)
3. Closing coil (Cat.No 0 281 26/27/28/29/30)
4. Time-lag module for undervoltage release (Cat.No 0 288 62/63)
5. Motor operator (Cat.No 0 281 20/21/22/23/24)
6. Signalling contact for inserted/test/drawn-out position (Cat.No 0 281 73)
7. Contact «ready to close» and «charged spring» (Cat.No 0 281 74)
8. Module with 6 auxiliary contacts (Cat.No 0 281 75)
Module with 4 auxiliary contacts (Cat.No 0 281 76)
9. External neutral (Cat.No 6 696 05)
10. Power supply module EMS CX3 (Cat.Nos 4 149 45)
11. Terminal block layout and accessory location
12. Wiring diagrams

1 -Shunt trip (Cat.Nos 0 281 31/32/33/34/35)

i ST: Shunt Trip
UVR: Undervoltage Release
CC: Closing Coil



The current shunt trip allows instantaneous opening of the DMX-SP by energising the coil : negative safety.

The electrical signal is given by a NO external contact (for example an emergency stop) and not by the protection unit.

The shunt trip comes with a connector (male + female) to be inserted into C1 and C2 slots on the DMX-SP terminal block.

The shunt trip can be permanently energised.



The DMX-SP can be equipped with two shunt trips: the first is placed in the slot marked «ST» and the second is placed in the slot for the undervoltage release marked «UVR». In this case, the second shunt trip will be connected to terminals D1 and D2.

MOUNTING



Before any intervention, check that the DMX-SP is in the «OFF» position (contacts open), drawn-out position (if necessary) and the discharged spring.



After an opening command, it is necessary to allow a period of 50 ms before issuing a closing command.

Remove the 4 screws (Phillips head n°1) and the front panel.

Cat.Nos	Operating voltage
0 281 31	24 V ~/ \equiv
0 281 32	48 V ~/ \equiv
0 281 33	110 - 130 V ~/ \equiv
0 281 34	220 - 250 V ~/ \equiv
0 281 35	415 - 440 V ~

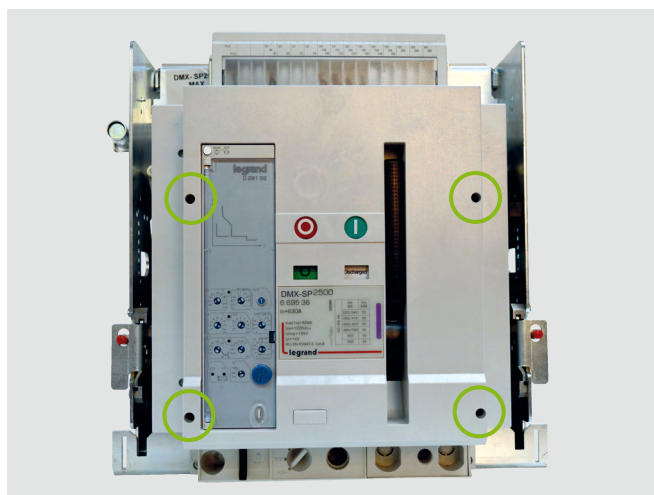

TECHNICAL CHARACTERISTICS

Rated voltage (Uc)	AC : 24 V ; 48 V ; 110 V to 130 V ; 220 V to 250 V ; 415 V to 440 V DC : 24 V ; 48 V ; 110 V to 130 V ; 220 V to 250 V
Operating voltage range (%Uc)	70 to 110
Pick-up consumption (W/VA)	400/400
Response time (ms)	300
Hold consumption (W/VA)	5/5
Opening time (ms)	50
Insulation voltage (kV)	2.5

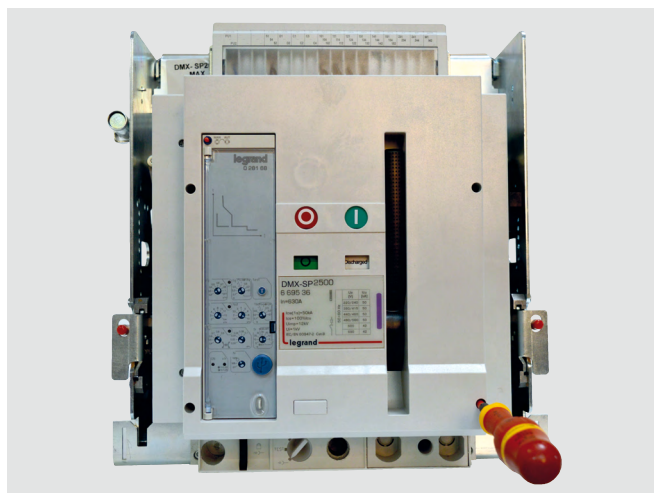

DMX-SP 2500 ELECTRICAL ACCESSORIES

Remove the plastic cover from the terminal block.



Remove the screw (Phillips head n°2) from the shunt trip support plate and remove the plate.

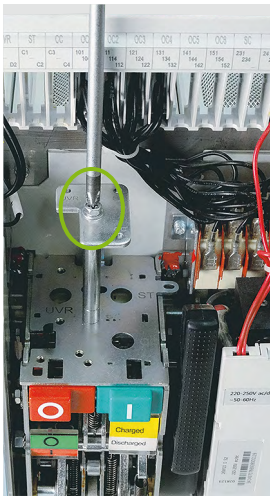

Top view of the coil support plate.

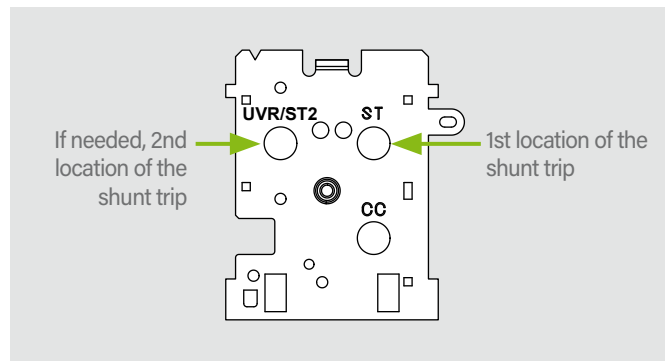

Insert the metal pins of the shunt trip correctly into the holes of the DMX-SP.

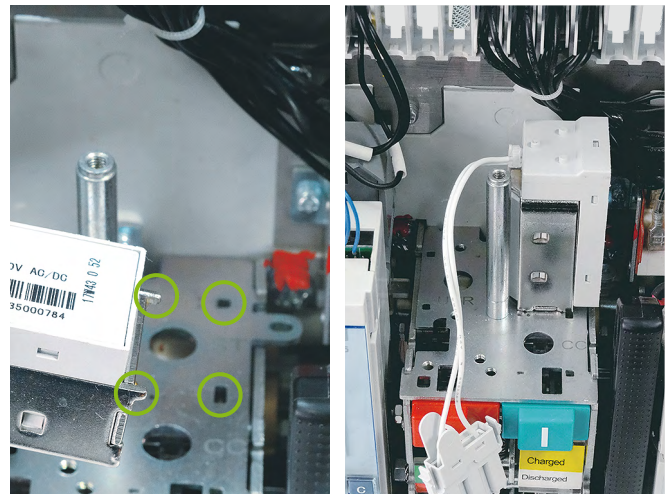

Replace and screw the support plate (Phillips head n°2, tightening torque 3 Nm).

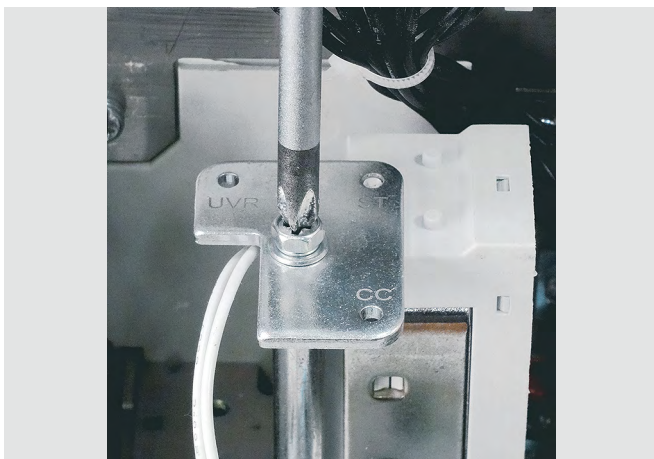

Clip the connector and terminal block into the dedicated slots: here ST (Shunt Trip).

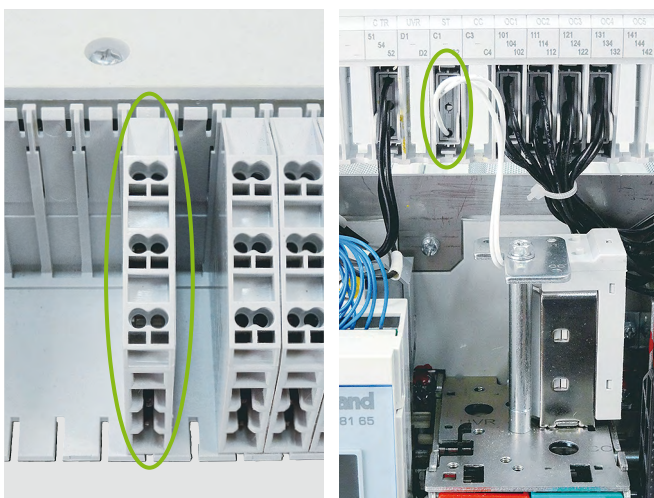

! For a fixed version, it is necessary to remove the OC1 and OC2 terminal blocks in order to access the hole provided for the screwdriver passage (in order to fix the support plate).

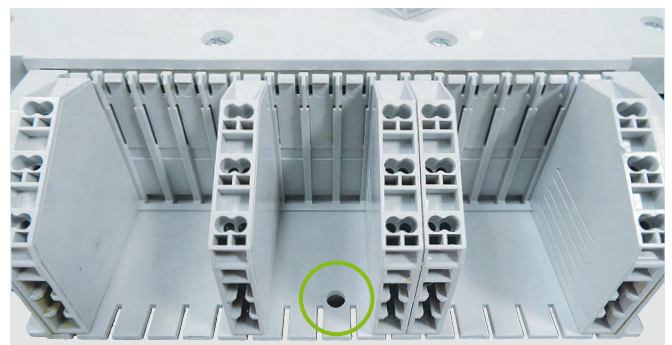

Replace the plastic cover of the terminal block, then the front panel using the 4 screws (Phillips head n°1, tightening torque 1 Nm), then the screw caps.

Re-insert the DMX-SP if necessary.



Cables are visually marked according to the type of tripping unit:

- White: Shunt Trip (ST):



2 - Undervoltage release (Cat.Nos 0 281 36/37/38/39/40)

- i** ST: Shunt Trip
- UVR: Undervoltage Release
- CC: Closing Coil

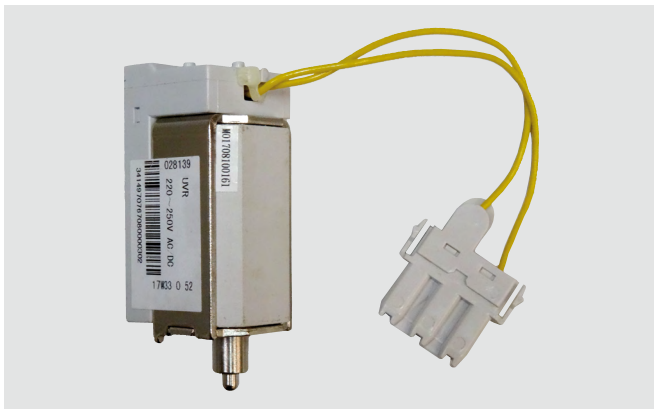

The undervoltage release allows instantaneous opening of the DMX-SP by powering off the coil: positive safety.

The electrical signal is given by a NC external contact (for example an emergency stop) and not by the protection unit.

The undervoltage release comes with a connector (male + female) to be inserted into slots D1 and D2 on the DMX-SP terminal block.

The DMX-SP can take only one undervoltage release.

The latter must be in the slot marked «UVR».

Cat.Nos	Operating voltage
0 281 36	24 V ~/=
0 281 37	48 V ~/=
0 281 38	110 - 130 V ~/=
0 281 39	220 - 250 V ~/=
0 281 40	415 - 440 V ~

TECHNICAL CHARACTERISTICS

Rated voltage (Uc)	AC: 24 V ; 48 V ; 110 V to 130 V ; 220 V to 250 V ; 415 V to 440 V DC: 24 V ; 48 V ; 110 V to 130 V ; 220 V to 250 V
Operating voltage range (%Uc)	85 to 110
Pick-up consumption (W/VA)	400/400
Response time (ms)	300
Hold consumption (W/VA)	5/5
Opening time (ms)	60
Insulation voltage (kV)	2.5

MOUNTING



Before any intervention, check that the DMX-SP is in the «OFF» position (contacts open), drawn-out position (if necessary) and the discharged spring.



Cables are visually marked according to the type of trip unit:

- Yellow: Undervoltage Release (UVR)

Top view of the coil support plate

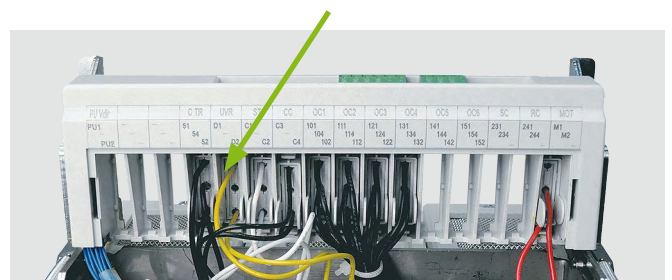
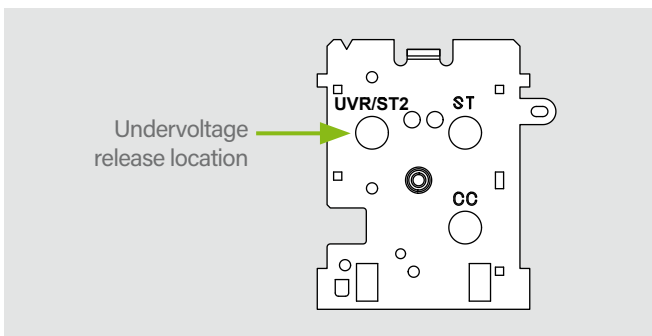

The assembly operations are identical for both shunt trip and undervoltage release as well as for the closing coil. However, be sure to respect the dedicated slots and the specific installation requirements depending on the version (drawn-out or fixed).

3 - Closing coil (Cat.Nos 0 281 26/27/28/29/30)

- i** ST: Shunt Trip
- UVR: Undervoltage Release
- CC: Closing Coil



This accessory allows the closure of the DMX-SP by powering the coil (provided that all conditions are met: spring loaded, key lock in the correct position, etc.).

The electrical signal is given by a NO external contact (for example a PLC output) and not by the protection unit.

The closing coil comes with a connector (male + female) to be inserted into slots C3 and C4 on the DMX-SP terminal block. Only one closing coil can be installed per device. The latter must be placed in the 3rd slot marked «CC».

The closing coil can be under permanent voltage.

Cat.Nos	Operating voltage
0 281 26	24 V~/=
0 281 27	48 V~/=
0 281 28	110-130 V~/=
0 281 29	220-250 V~/=
0 281 30	415-440 V~

TECHNICAL CHARACTERISTICS

Rated voltage (Uc)	AC: 24 V ; 48 V ; 110 V to 130 V ; 220 V to 250 V ; 415 V to 440 V DC: 24 V ; 48 V ; 110 V to 130 V ; 220 V to 250 V
Operating voltage range (%Uc)	85 to 110
Pick-up consumption (W/VA)	400/400
Response time (ms)	300
Hold consumption (W/VA)	50/50
Opening time (ms) 50	50
Insulation voltage (kV)	2.5

MOUNTING

! Before any intervention, check that the DMX-SP is in the «OFF» position (contacts open), drawn-out position (if necessary) and the discharged spring.

Top view of the coil support plate

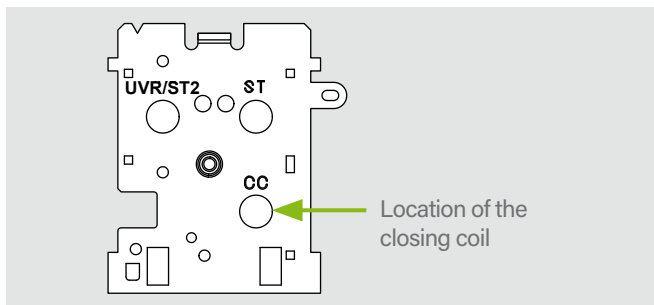

Cables are visually marked according to the type of trip unit:

- Black: Closing Coil (CC)



The assembly operations are identical for both shunt trip and undervoltage release as well as for the closing coil. However, be sure to respect the dedicated slots and the specific installation requirements depending on the version (drawn-out or fixed).

4 - Time-lag module for undervoltage release (Cat.Nos 0 288 62/63)

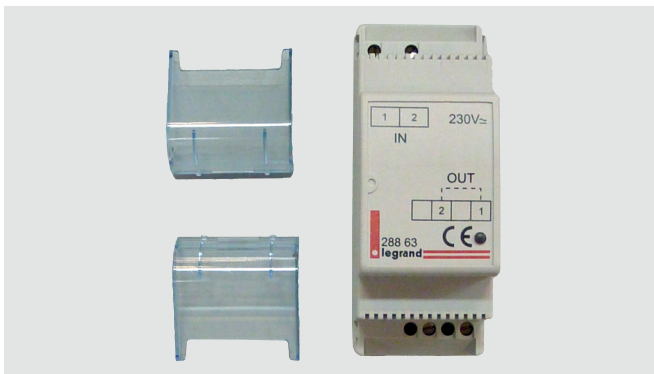

These modules are used to delay the intervention of an undervoltage release installed in a DMX-SP, up to three seconds during a micro-break. These delay modules work with standard undervoltage releases Cat.No 0 281 38 (110 V) and Cat. No 0 281 39 (230 V).

A single module is used to obtain a delay of one second. Connecting three modules in series obtains a maximum delay of three seconds.

When using an emergency stop, it must be of NC type, and it should be placed between the output of the last time-lag module and the undervoltage release.

Before turning on the time-lag module, you must ensure that the undervoltage release is properly connected. Power the module for at least one second to obtain its full operating capacity. Multiply this time by the number of modules installed.

Before working on downstream the wiring of the time-lag module, wait a minute after switching off the power supply to avoid any electric shocks.

The protection of this delay module must be placed upstream of the DMX-SP where the undervoltage release will be installed.

Cat.Nos	Operating voltage
0 288 62	110 V ~ / ∞
0 288 63	230 V ~ / ∞

TECHNICAL CHARACTERISTICS

Rated voltage (Uc)	AC : 110 V/230 V DC : 110 V/230 V
Operating voltage range(%Uc)	85 to 110
Pick-up consumption (W/VA)	16.5 (to 110 V)/34.5 (to 230 V)
Delay (s) to Uc	1 ⁽¹⁾
Hold consumption (W/VA)	5 (to 110 V)/10 (to 230 V)
Opening operating threshold	0.35 to 0.7 Un
Closing operating threshold	0.85 Un
Operating temperature (°C)	- 10 to + 55

(1) up to 3 modules -1s delay for each module installed

MOUNTING

Example with Cat.No 0 288 63 (identical mounting for Cat.No 0 288 62):

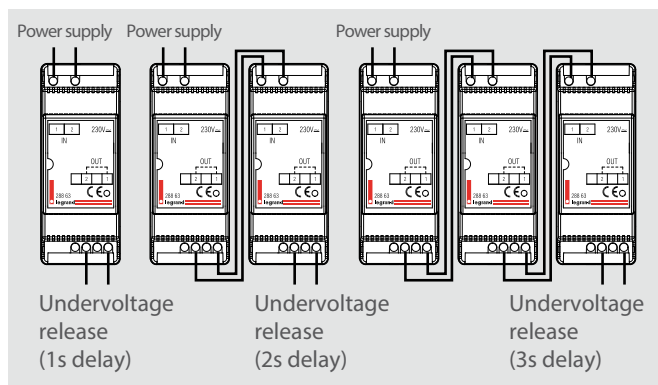

5 - Motor operator (Cat.Nos 0 281 20/21/22/23/24)



The motor operator is used to automatically reset the closing spring. Its starting and stopping are automatic if voltage is present at its terminals.

It is preferable to have a constant voltage at the terminals so that the DMX-SP can operate quickly.

The motor operator comes with a connector (male + female) to be inserted into M1 and M2 slots on the DMX-SP terminal block.

In parallel with its installation, it is possible to add a control auxiliary (undervoltage release or shunt trip) and a closing coil. If there is no longer any voltage at the terminals of the motor operator, it is always possible to manually recharge the spring.

Cat.Nos	Operating voltage
0 281 20	24 V ~/≡
0 281 21	48 V ~/≡
0 281 22	110 - 130 V ~/≡
0 281 23	220 - 250 V ~/≡
0 281 24	415 - 440 V ~

TECHNICAL CHARACTERISTICS

Rated voltage (Uc)	AC : 24 V ; 48 V ; 110 V to 130 V ; 220 V to 250 V ; 415 V to 440 V DC : 24 V ; 48 V ; 110 V to 130 V ; 220 V to 250 V
Operating voltage range (%Uc)	85 to 110
Max. dissipated power (W/VA)	240/240
Max. Current for 80ms	(2 to 3) x In
Charging time (s)	5
Operating frequency (cycles/min)	2

• Fuse type integrated in the motor operator

Motor operator	Fuse type
0 281 20	250 V - 10 A T - 5 x 20 mm
0 281 21	250 V - 5 A T - 5 x 20 mm
0 281 22	250 V - 2,5 A T - 5 x 20 mm
0 281 23	250 V - 1,25 A T - 5 x 20 mm
0 281 24	250 V - 0,8 A T - 6,3 x 20 mm

MOUNTING



Before any intervention, check that the DMX-SP is in the «OFF» position (contacts open), drawn-out position (if necessary) and the discharged spring.

Remove the 4 screws (Phillips head n°1) and the front panel.

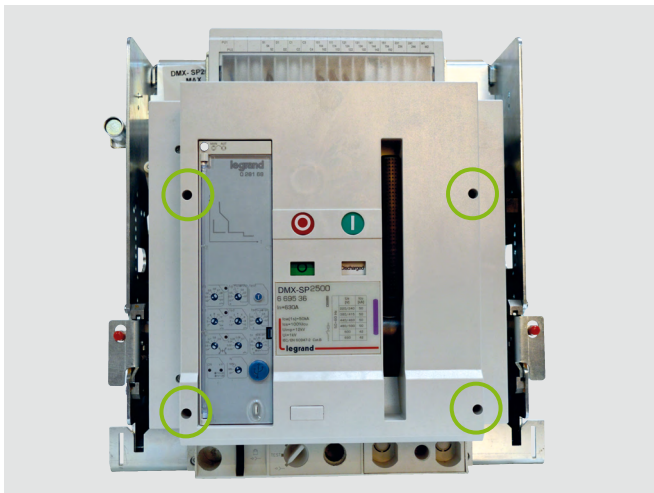

Insert the motor operator by aligning the spline of the axis with the keyway of the motor operator.

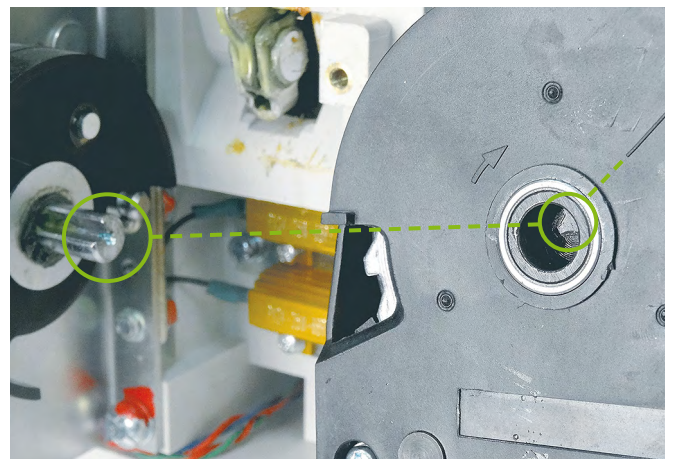

Insert the metal plate correctly and secure it with the screw and washer provided (Phillips head n°2, tightening torque 3 Nm).

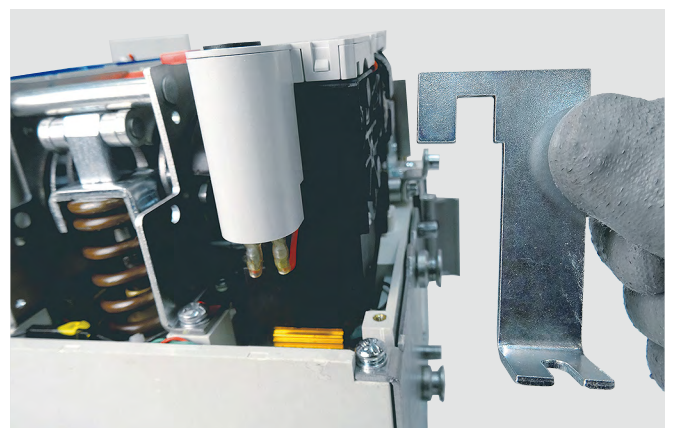
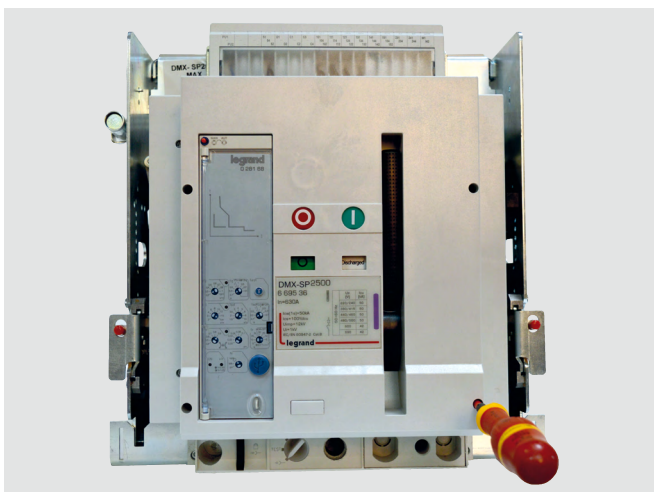

DMX-SP 2500 ELECTRICAL ACCESSORIES

Bottom view.



Fix the 2nd motor operator holding screw (Phillips head n°2, tightening torque 3 Nm).

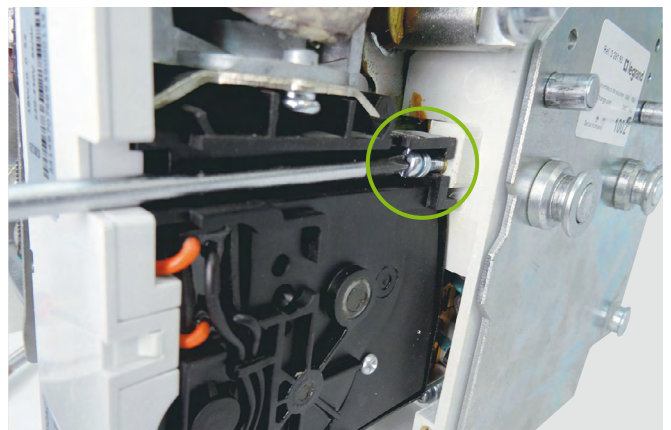

Screw location.

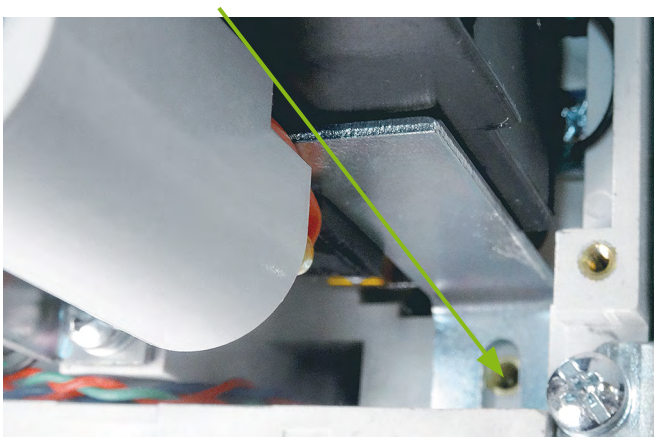

Clip the connector and terminal block into the dedicated slots: here MOT (M1/M2).

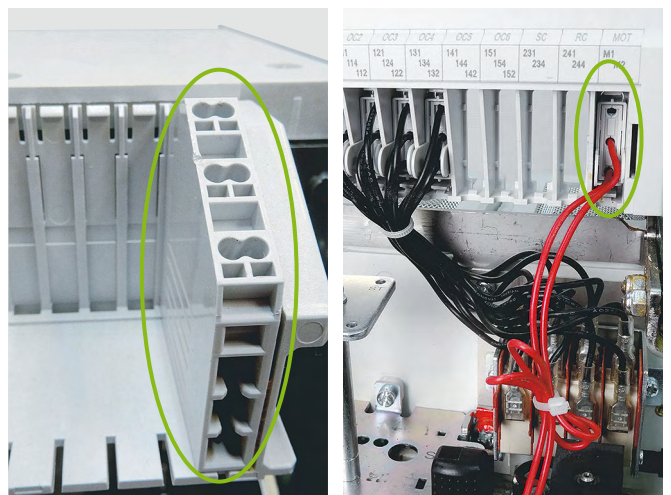

Replace the plastic cover of the terminal block, then the front panel using the 4 screws (Phillips head n°1, tightening torque 1 Nm), then the screw caps.

Re-insert the DMX-SP if necessary and carry out 2 operating tests.

6 - Signalling contact for inserted/test/drawn-out position (Cat.No 0 281 73)



These contacts allow you to remotely report the position of a Draw-out version DMX-SP in its base: «inserted», «test» or «drawn-out».

Each contact has a specific function that cannot be modified.

The block has 3 contacts: 1 for the presence of DMX-SP in the base («inserted»), 1 for the «test» position and 1 for the «drawnout » position.

These contacts are of the changeover type (NO-NF) with dry contact (potential-free). It is possible to install a maximum of 2 contact blocks per DMX-SP (Draw-out version): therefore 2 contacts maximum per position.

The wiring at the contacts is already done, the cable ends can be connected to an external terminal block.



The length of the cables coming out of the base is 1400 mm. Their cross-section is 0.5 mm².



If the base is equipped with a locking button Cat. No 0 281 87, it is not possible to install a 2nd contact Cat No 0 281 73 on the right side of the base (front view).

TECHNICAL CHARACTERISTICS

Rated voltage (Uc)	DC	125 V 0,6 A 250 V 0,3 A
	AC	125 V 5 A 250 V 5 A

Layout and wiring principle

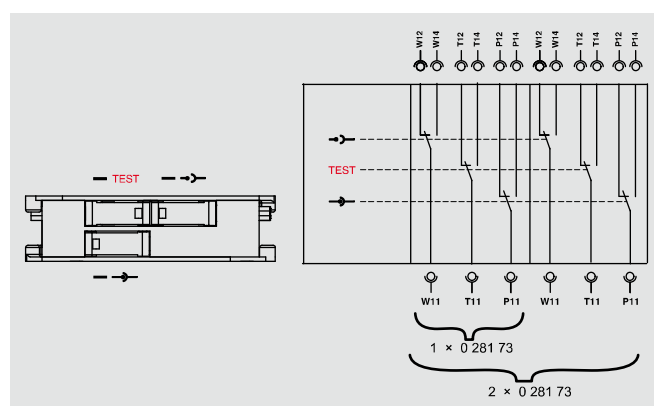

DMX-SP 2500 ELECTRICAL ACCESSORIES

MOUNTING



Before any intervention, check that the DMX-SP is in the «OFF» position (contacts open), drawn-out position (if necessary) and the discharged spring.

Mounting is identical on the right or on the left side, respecting the mounting direction described in the installation instructions.

Mounting example on the left

Install the plastic bracket in the position shown below and secure it with the screw provided (Phillips head n°2, tightening torque 3 Nm).

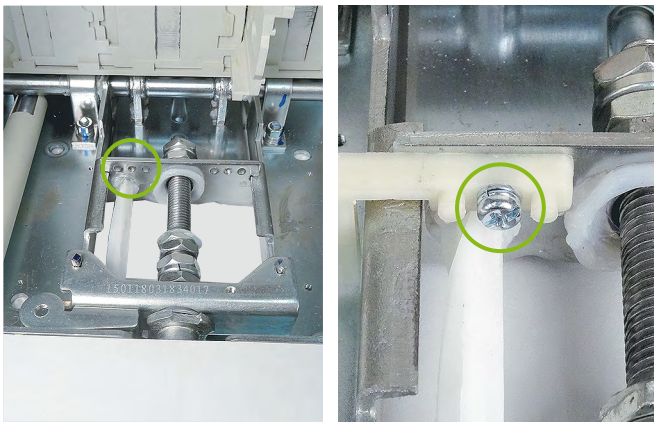

Run the contact wires through the back of the base:



Back of the base

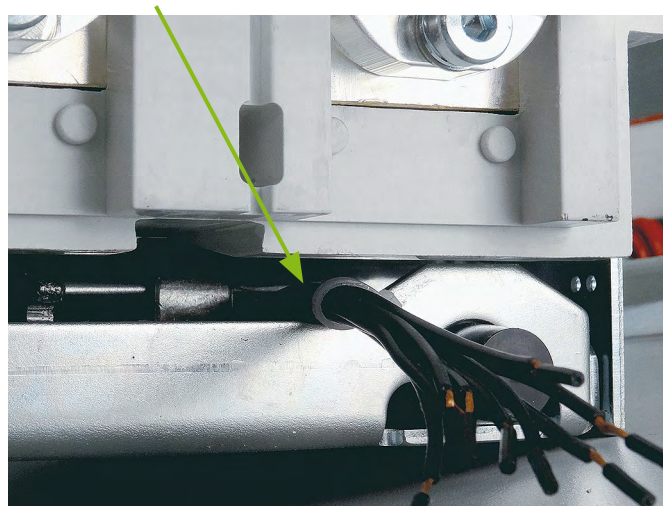

Fix the contact block with the 2 screws provided (Phillips head n°1, tightening torque 1 Nm).



Re-insert the DMX-SP and perform a mechanical and electrical operating test by trying all positions (inserted/test/drawn-out).

7 - Contact « ready to close» and «charged springs» (Cat.No 0 281 74)



This contact block provides remote feedback of two distinct types of information:

- Device ready to close (RC): the contact is closed when the spring is charged, as long as there is no fault detected on the circuit breaker and all safety systems allowing closure are inactive.
- Spring charged (SC): the contact is closed when the spring is fully charged (electrically or manually).

These contacts are volt-free changeover (NO) contacts.

On the DMX-SP terminal block, the «ready to close» contact is connected to slot «RC» at terminals 241/244 and the «spring charged» contact to slot «SC» at terminals 231/234.

TECHNICAL CHARACTERISTICS

Rated operating voltage (Vn)	AC	125 V/3 A 250 V/0,5 A
	DC	30 V/3 A

MOUNTING



Before any intervention, check that the DMX-SP is in the «OFF» position (contacts open), drawn-out position and the discharged spring.

Remove the 4 screws from the front panel (Phillips head n°1) and the front panel.

If there is a motor operator, dismantle it beforehand.

Position the contact, insert and tighten the fixing screw (Phillips head n°1, tightening torque 1 Nm).

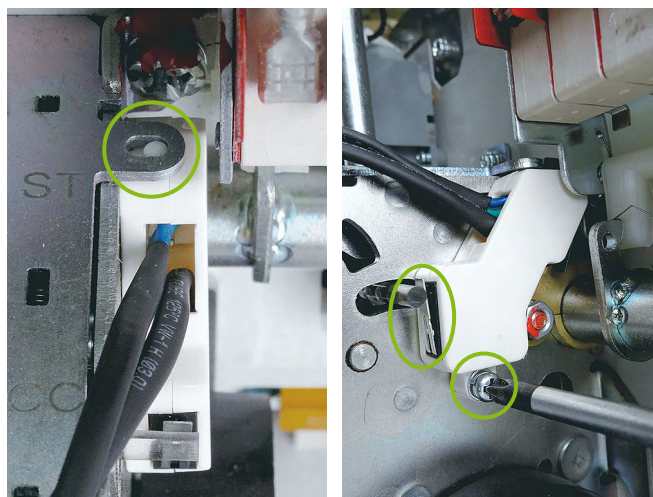

DMX-SP 2500 ELECTRICAL ACCESSORIES

Clip the 2 connectors at the specific points according to the identified marking.

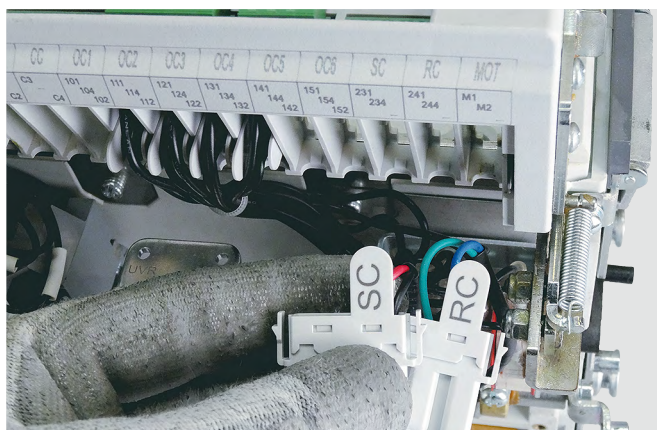

Replace the plastic cover of the terminal block, then the front panel using the 4 screws (Phillips head n°1, tightening torque 1 Nm), then the screw caps.

Re-insert the DMX-SP if necessary and carry out 2 operating tests.

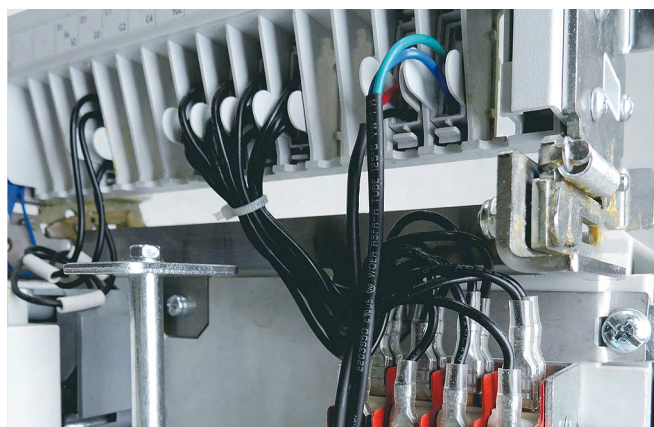

8 - Module with 4 (Cat.No 0 281 76) or 6 auxiliary contacts (Cat.No 0 281 75)

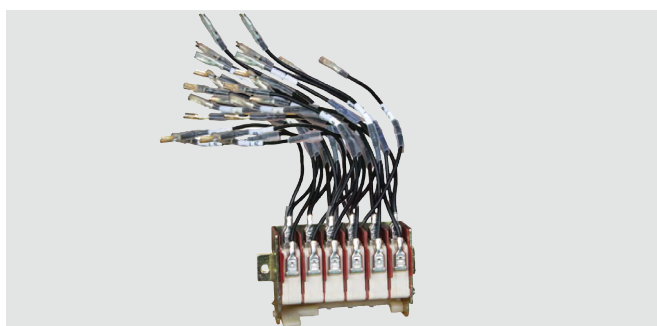

The auxiliary contacts are used to remotely signal the position of the main DMX-SP contacts.

These contacts are volt-free changeover (NO/NC) contacts.

When the DMX-SP terminals are open, the contact is made between terminals 1x1 and 1x2.

All DMX-SP and DMX-SP-I are delivered with a block of 1 auxiliary contact already installed. This must be dismantled when installing the new block of 4 or 6 contacts.

These contacts are delivered with their male connector (4 or 6) and 3 or 5 female connectors (the 4 original female connectors are kept).

See wiring layout paragraph 12 (page 40).

TECHNICAL CHARACTERISTICS

Rated operating voltage (Vn)	DC	250 V 0.3 A
	AC	250 V 16 A

9 - External Neutral (Cat.No. 6 696 20)



The current sensor is factory-assembled only on the 150 mm bar. The external neutral can only be used with 3-pole circuit breakers (fixed or Draw-out version) and is installed in the following cases:

- Neutral protection with all protection unit versions
- Earth fault protection with protection units including activated Ig

It must be installed at the same level as the DMX-SP and its cable must be as far away as possible from disturbing electromagnetic sources (transformers, etc...) and power lines.

DIMENSIONS

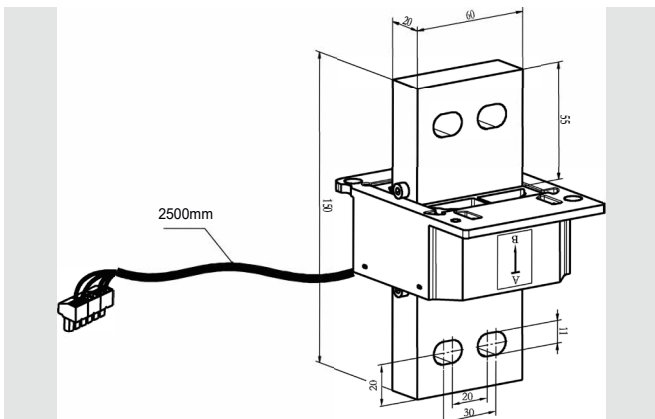

i The arrow indicates the direction of the current (to be respected).

MOUNTING

! Before any intervention, check that the DMX-SP is in the «OFF» position (contacts open), drawn-out position and the discharged spring.

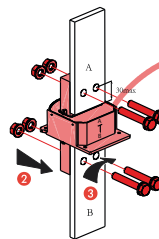

- Fix the bars on the external neutral (respecting the maximum distance between the axis of the holes and the end of the bars, see illustration above) using 4 sets of screws/nuts: the type of screws, nuts and the tightening torque are to be defined by the installer.
- Then insert the connector in the dedicated slot on the terminal block provided. See the installation of the protection unit terminal blocks (page 36).
- Stick the information label on the front panel.



! Do not close the DMX-SP without first inserting the connector into the terminal block.
Do not remove the connector without first opening the DMX-SP.

10 - Power supply module EMS CX³

The power supply Cat.No 4 149 45 integrate the modular system EMS CX³ for the energy monitoring within the electric boards. It is mandatory to use this supply, dedicated to the EMS CX³.

This module distributes power via the rail and/or the communicating cables.

TECHNICAL CHARACTERISTICS

- Display: none
- Power supply: primary 95 to 250 Vac secondary 12Vcc 0.5A
- Settings: none
- Addressing: none
- Connexion:
 - power supply via screw terminals;
 - power distribution via rail or specific cables.
- Mounting: on DIN rail
- Dimensions: 1 module
- Supplied with a white cable for galvanic separation.



For more information, see technical sheet.

The number of power supply 4 149 45 in an EMS CX³ system depends on the power required for the proper operation of the module. A power supply module can supply up to **500 mA**. If the installation requires more power, a new power supply module must be planned. The same BUS EMS CX must not exceed 1.5 A: i.e. **3 power supply modules maximum**.

The total power supply modules allowed under a power supply depends on the sum of their consumption.



The length of all cables of the EMS system must not exceed 3m.

1 EMS CX³ system
1 power supply module

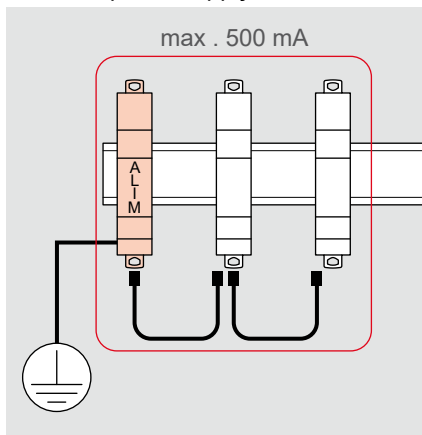

1 EMS CX³ system
2 power supply modules

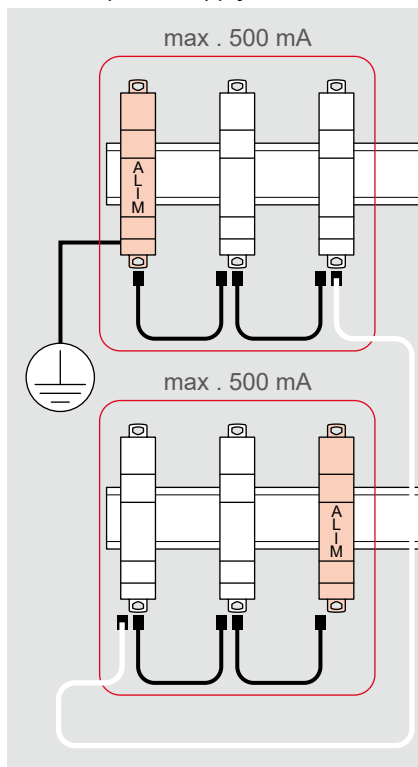

1 EMS CX³ system
3 power supply modules

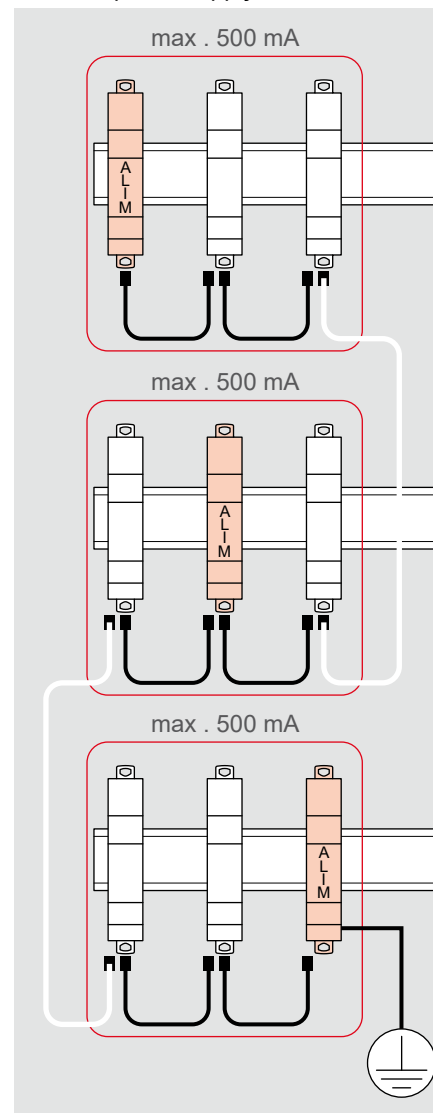

i In the case of 1 or 2 power supplies, they must be installed to each end of the EMS CX³ system.

In the case 3 power supplies, 2 must be installed to each end of the EMS CX³ system, and the 3rd in the middle.

Beware, each set must be linked by a white cordon.

i 2 power supplies cannot be installed on the same communicating rail.

! Each set composed of «one power supply module and its EMS CX³ modules » must be separated by a special link including mandatorily a white cable (delivered with each power supply module).

! In case of many power supply modules in the same system, only one power supply module must be earthed.

CONNECTION

- Power supply of the module:

Screw connection at the bottom of the module.



i To protect the power supply module, see indications on the product technical sheet, available on the e-catalog.

- Le BUS EMS CX³:

2 solutions are possible for the connection to the BUS:



By the back of the modules via communicating rails Cat.Nos 4 149 01/02/03

! The modules cannot slide on the rail once they are in place.

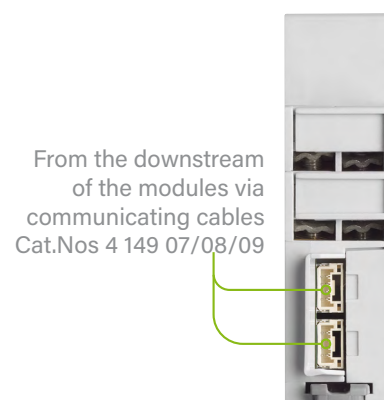

From the downstream of the modules via communicating cables Cat.Nos 4 149 07/08/09

i The EMS CX³ bus connection specifications are common to all EMS CX³ products.
 For more details, and to know the consumer of all the modules EMS CX³, see the technical sheet, available on the e-catalog.

DMX-SP 2500 ELECTRICAL ACCESSORIES

Protection units can be connected to EMS CX³ system with connection cables Cat.No 4 149 07/08/09 and connector Cat.No 4 149 10.

- 4 149 07: EMS connection cable 250 mm length
- 4 149 08: EMS connection cable 500 mm length
- 4 149 09: EMS connection cable 1000 mm length

 The length of all cables of the EMS system must not exceed 3m.

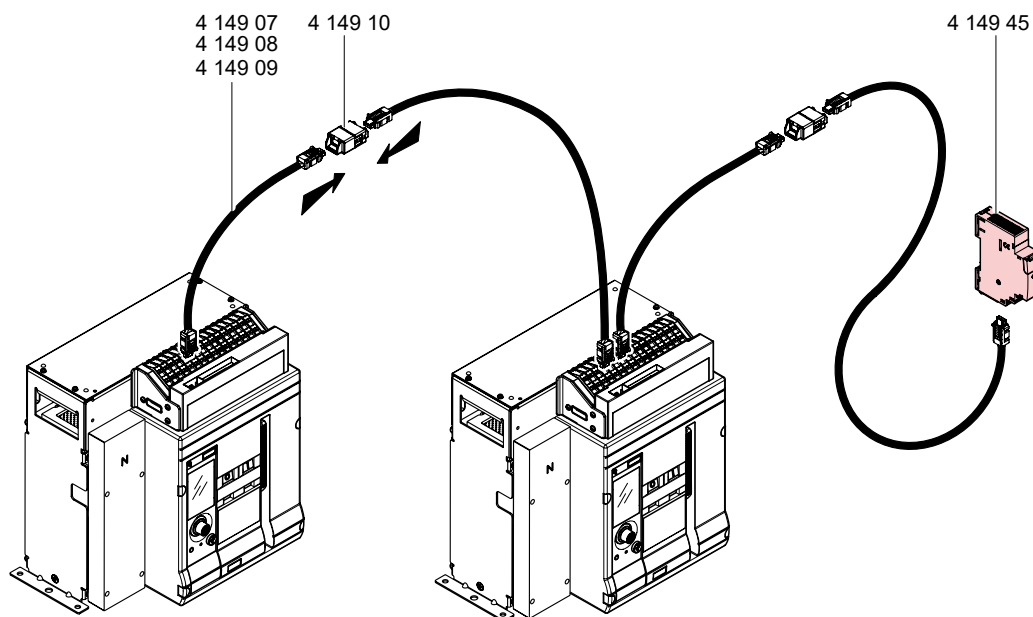

 A power supply module can supply up to 500 mA. A calculation of the consumption must be carried out to ensure proper operation of the system.

TABLE OF CONSUMPTIONS

Cat.Nos	Designation	Maximum consumption
0 283 00	MP2.10 protection unit without measure	55 mA
0 283 01	MP2.10 protection unit with measure	69 mA
0 283 02	MP4.10 protection unit without measure	62,5 mA
0 283 03	MP4.10 protection unit with measure	80 mA

11 - Terminal block layout and accessory location

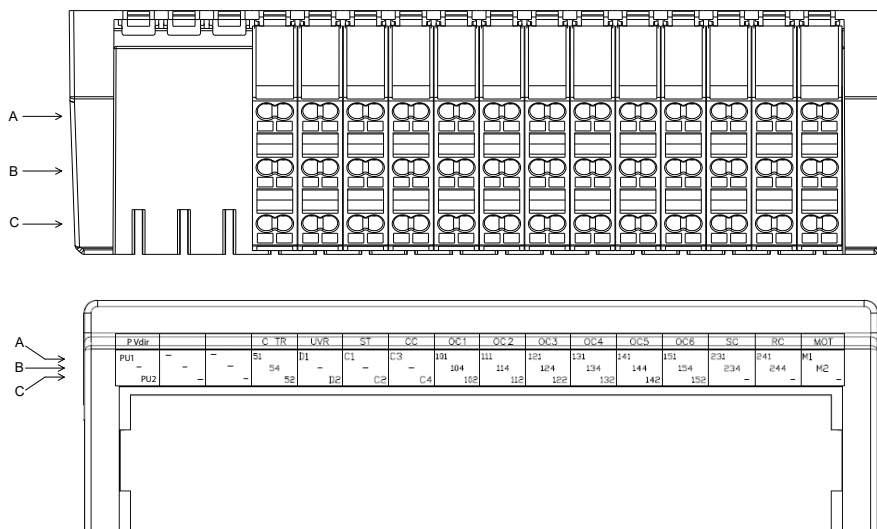

- Automatic spring-cage terminals
 - Insert a flat screwdriver (3 mm): the spring opens.
 - Insert the cable.
 - Remove the screwdriver: the spring automatically blocks the cable.

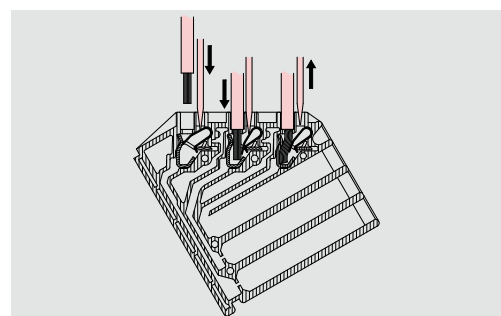

A spring-cage terminal accepts a maximum cross-section of 2,5 mm²/ cable and a maximum number of 2 cables. It is also possible to insert 2 cables of different sections while respecting the tolerances detailed below.

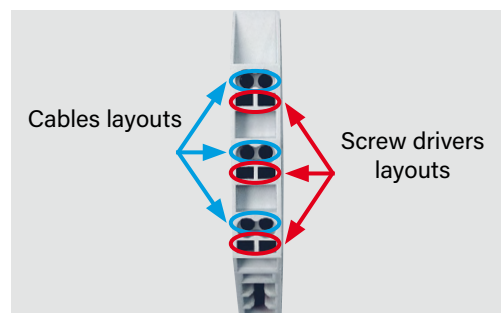

• Recommended cross-sections

Rigid cable		1 to 2,5 mm ²
Flexible cable without ferrule		1 to 2,5 mm ²
Flexible cable with flanged end cap		1 to 1,5 mm ²
Flexible cable with collarless endcap		2,5 mm ²

• Recommended stripping length (optimal: 11 mm)

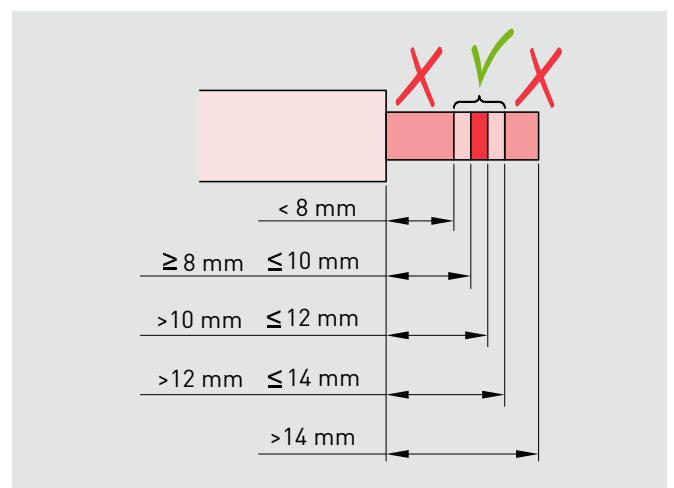

• Terminals concerning the protection unit

Draw-out version: wire the circuit breaker in the fully withdrawable position

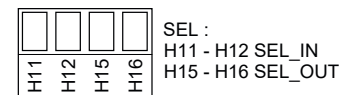
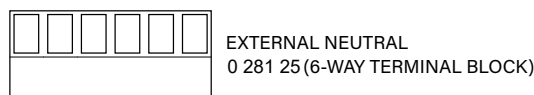
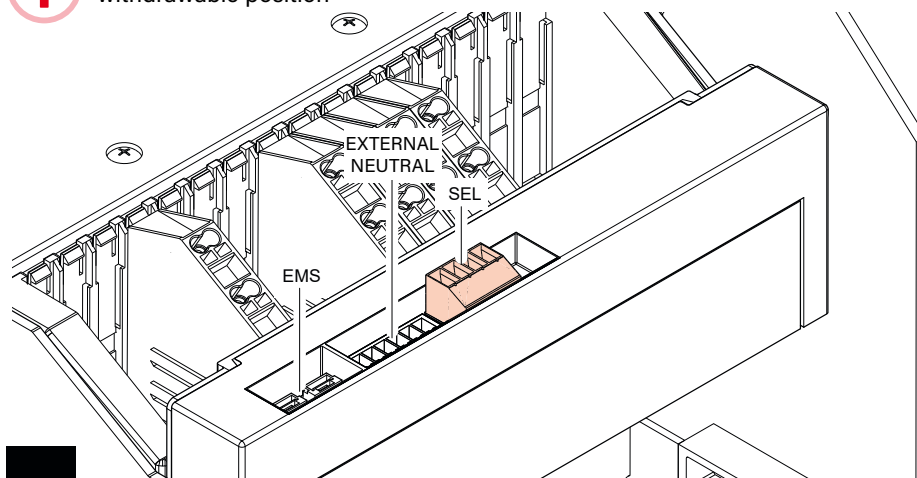

12 - Wiring diagrams

3P CIRCUIT BREAKER WITH MEASURE AND 3P+N EXTERNAL WITH ENERGY METER

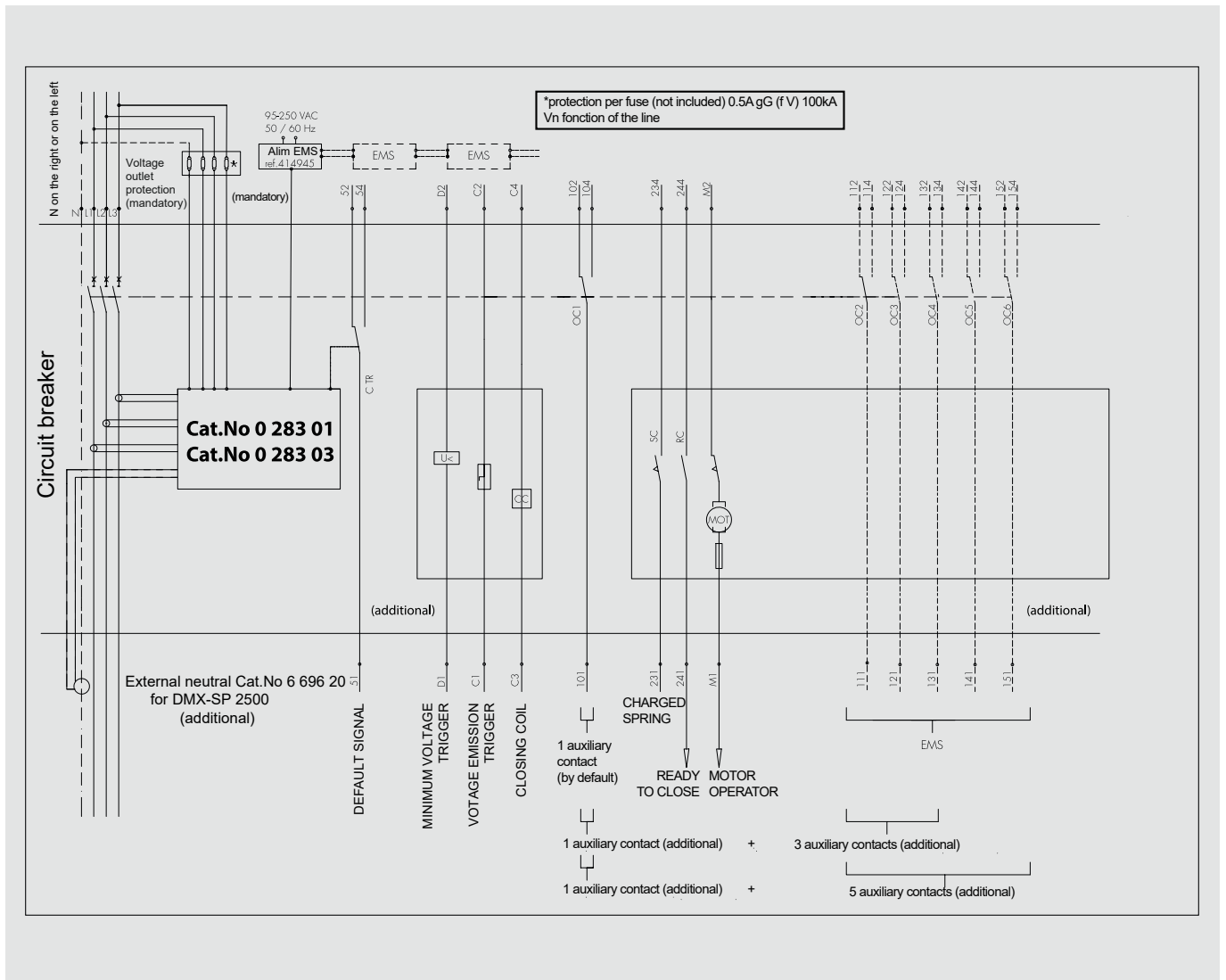

4P CIRCUIT BREAKER WITH MEASURE

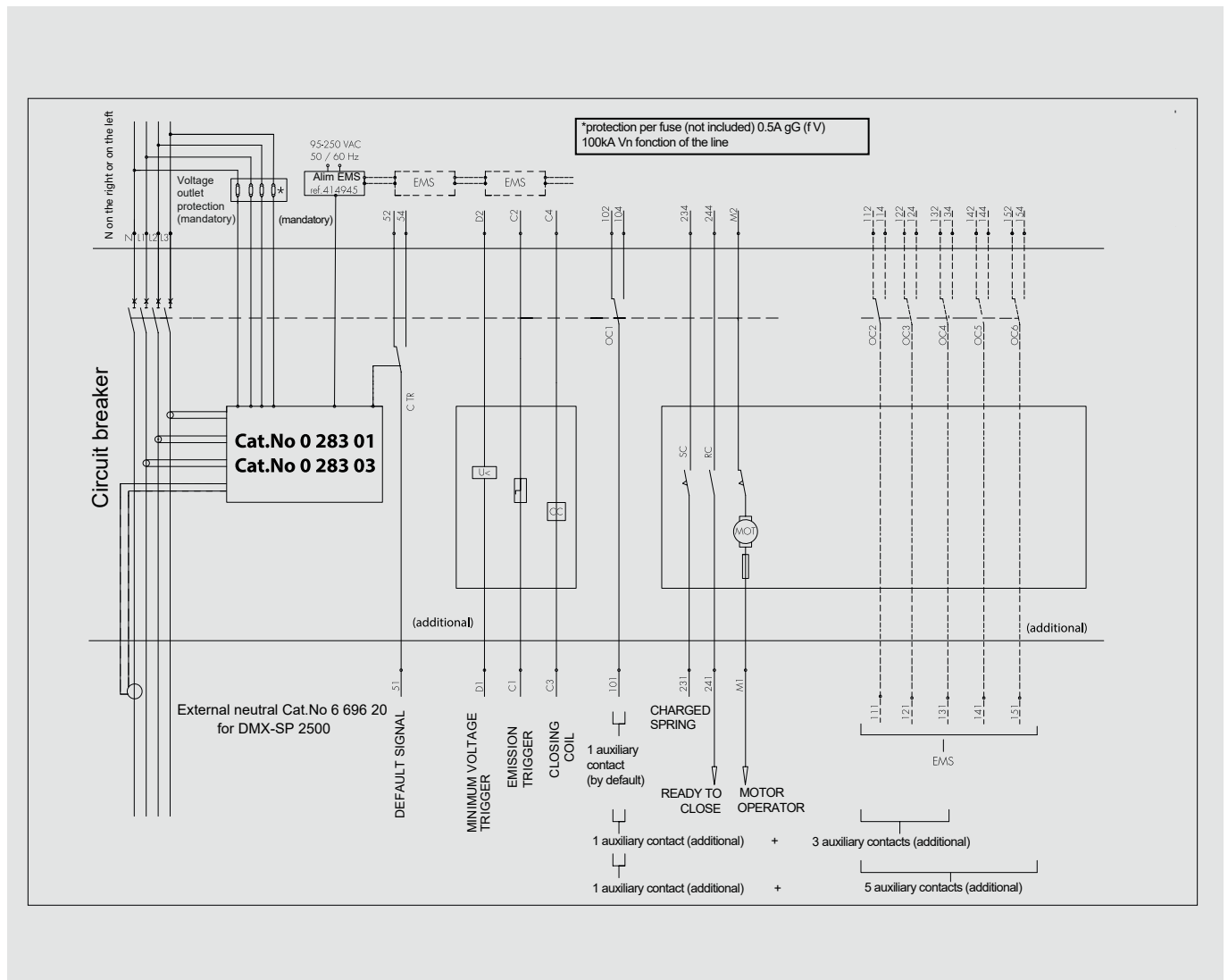

DMX-SP 2500 ELECTRICAL ACCESSORIES

3P CIRCUIT BREAKER AND 3P+N EXTERNAL

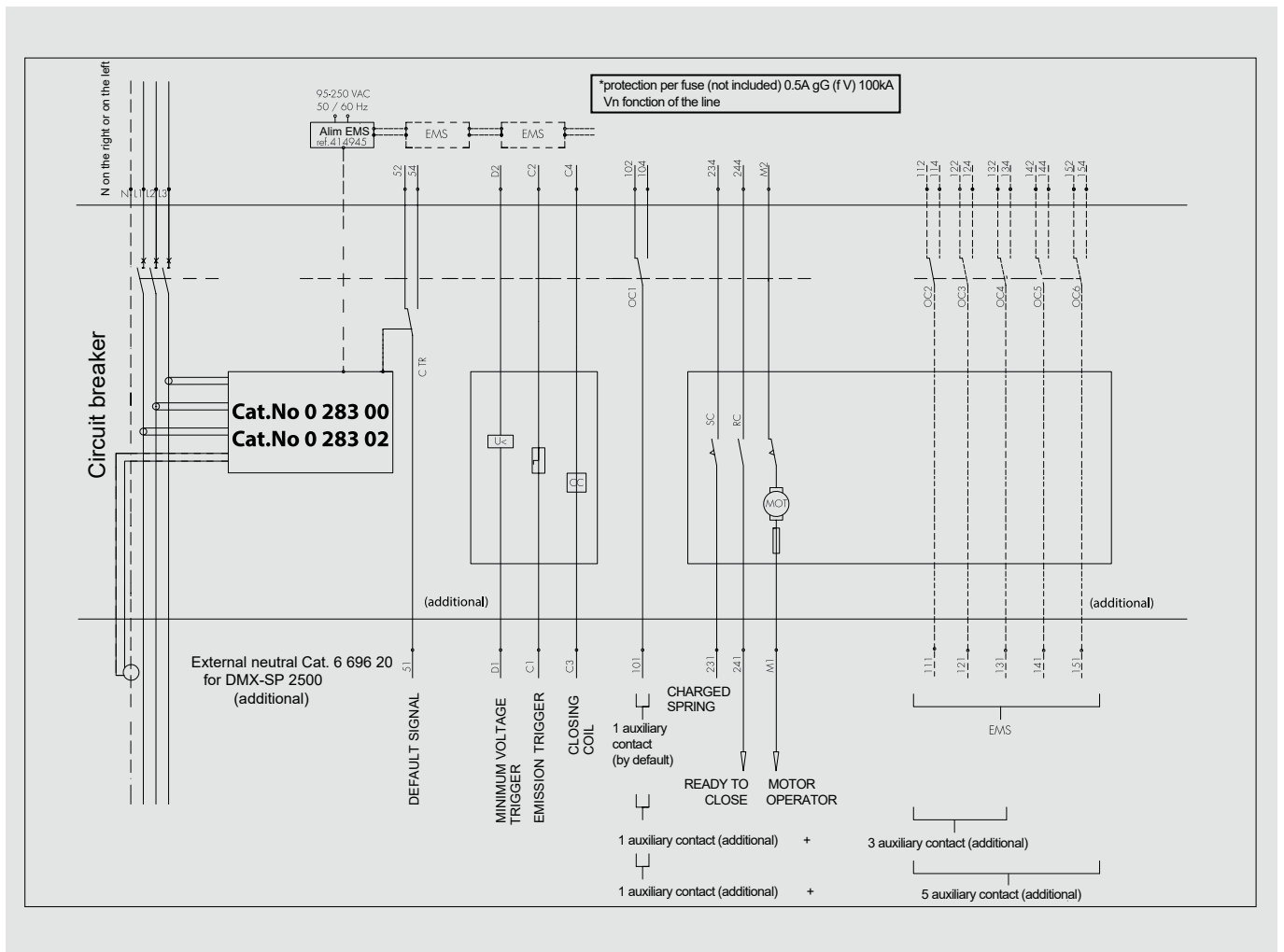

4P CIRCUIT BREAKER

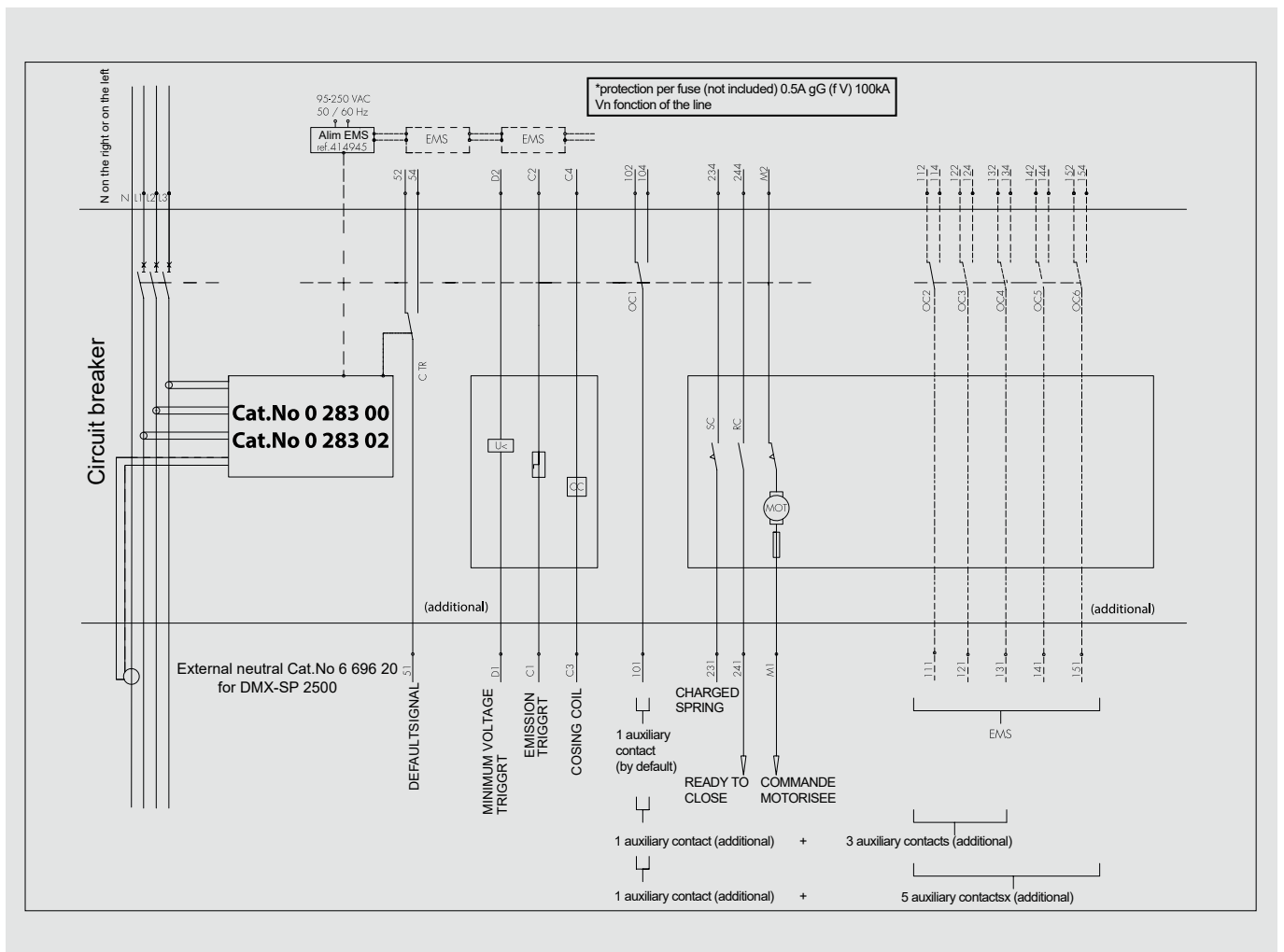

3P TRIP FREE SWITCH

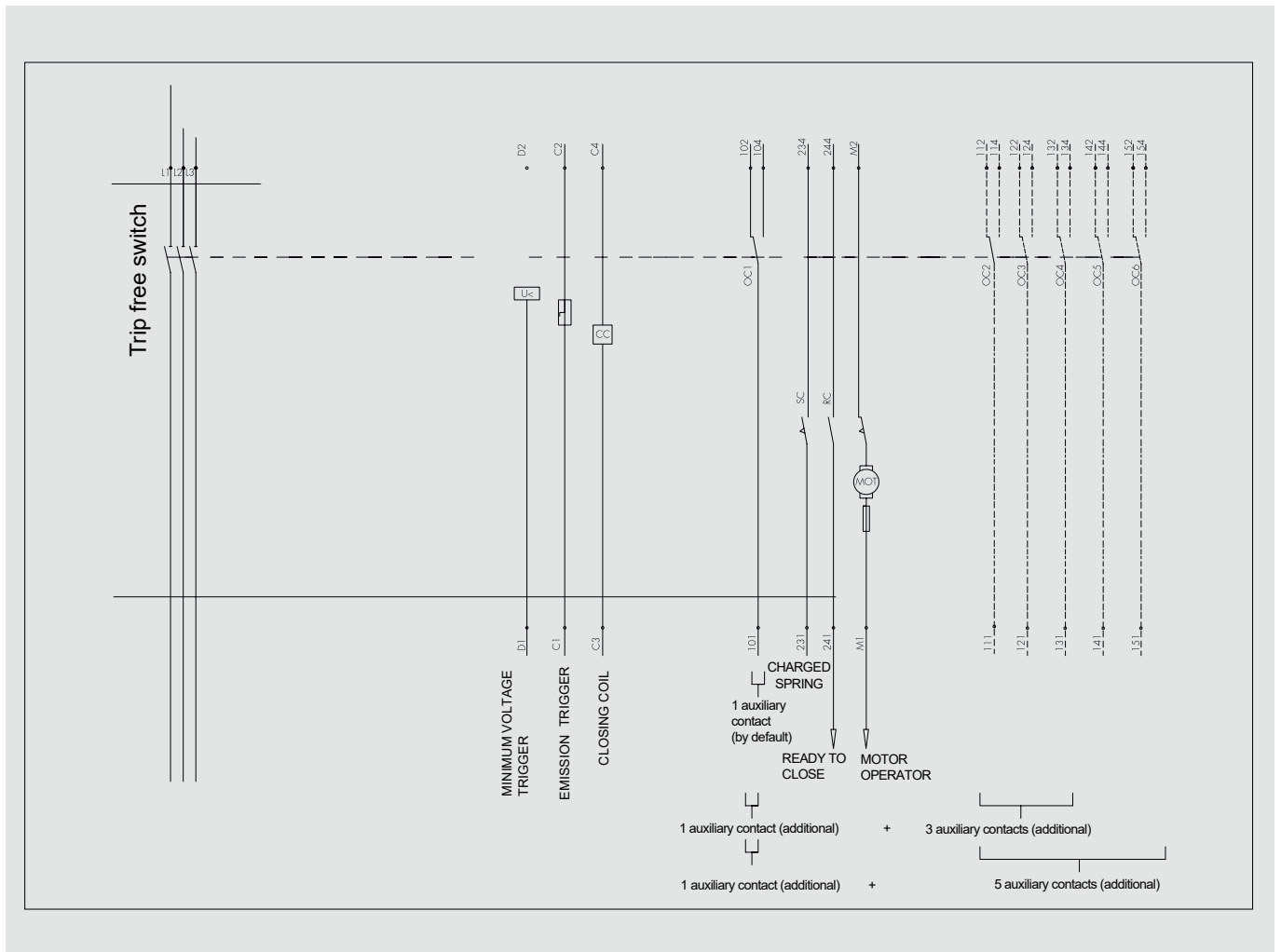

4P TRIP FREE SWITCH

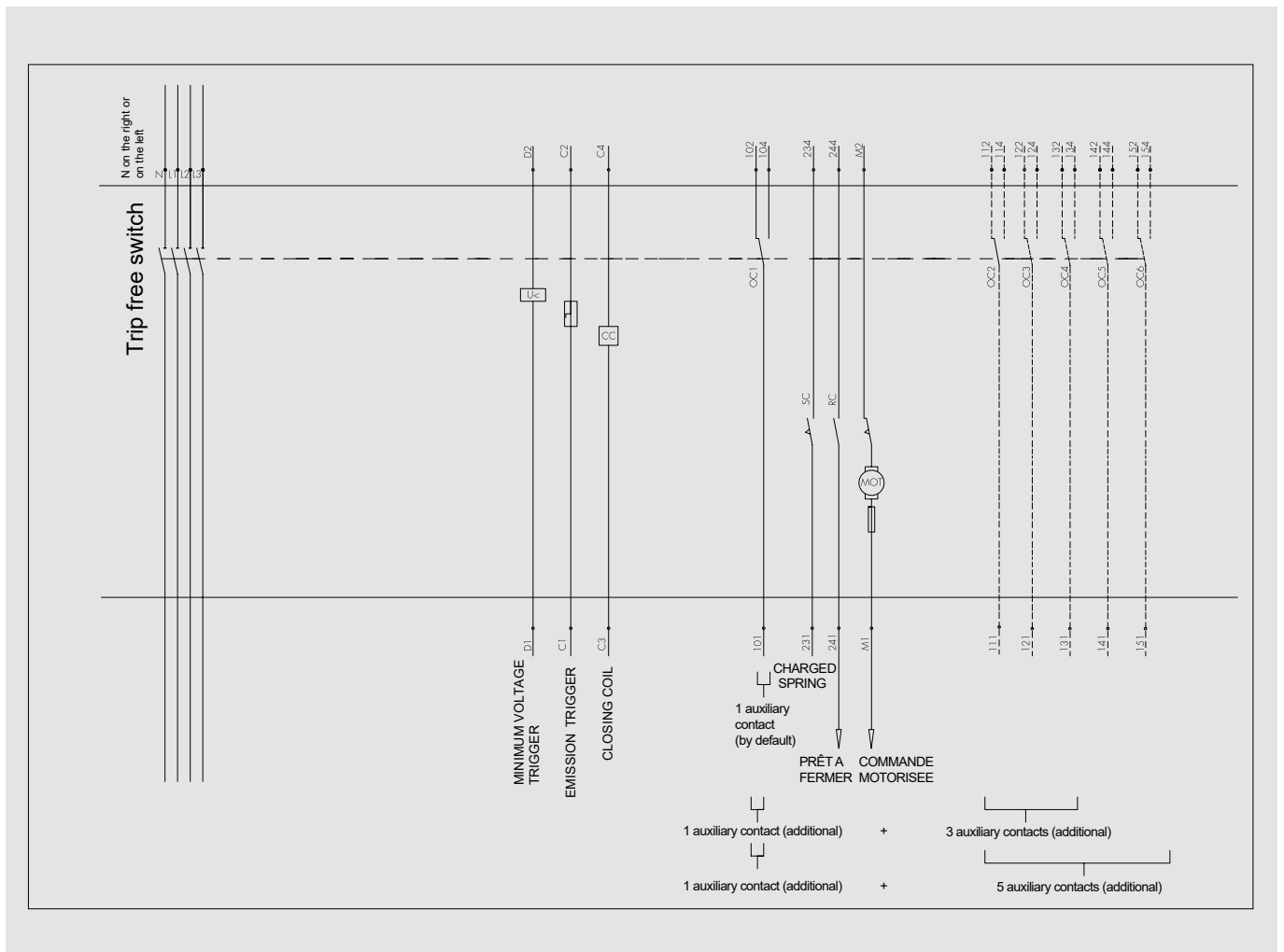

ELECTRICAL ACCESSORIES

DMX-SP 4000

1. Current release shunt trip (Cat.Nos 0 288 48/49/50/51/52)
2. Undervoltage release (Cat.Nos 0 288 55/56/57/58/59)
3. Closing coil (Cat.Nos 0 288 41/42/43/44/45)
4. Time-lag module for undervoltage release (Cat.Nos 0 288 62/63)
5. Motor operator (Cat.Nos 0 288 34/35/36/37/38/40)
6. Signalling contact for inserted/test/drawn-out position (Cat.No 0 288 13)
7. Contact «ready to close» and «charged spring» (Cat.No 0 288 14)
8. Auxiliary contact module (Cat.No 0 288 15)
9. Contact for signalling trip or coils status (Cat.No 0 288 16)
10. Power Supply module EMS CX³ (Cat.No 4 149 45)
11. Default contact (pre-installed on the circuit breaker)
12. External neutral (Cat.No 0 281 98)
13. Installation of the terminal block and location of the accessories
14. Wiring diagrams

1 - Current release shunt trip (Cat. Nos 0 288 48/49/50/51/52)



ST: Shunt Trip
UVR: Undervoltage Release
CC: Closing Coil



The current shunt trip allows instantaneous opening of the DMX-SP by energising the coil : negative safety.

The electrical signal is given by a NO external contact (for example an emergency stop) and not by the protection unit.

The shunt trip comes with a connector (male + female) to be inserted into C1 and C2 slots on the DMX-SP terminal block.

The shunt trip can support being energised permanently.



It is possible to equip a DMX-SP with two shunt trips: the first is placed in the slot identified as «ST», the second is placed in the slot of the undervoltage release identified as «UVR». In this case, this second shunt trip will be connected to terminals D1 and D2.

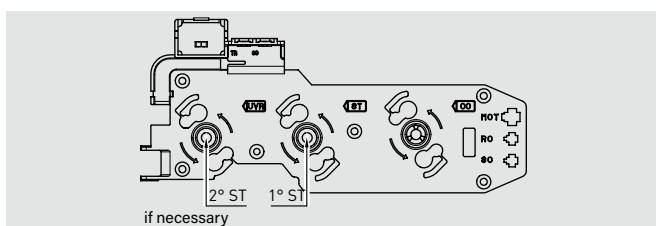

After an opening order, it is necessary to leave at least 50 ms before giving a closing order.

Cat.Nos	Operating voltage (Uc)
0 288 48	24 V ~/ \equiv
0 288 49	48 V ~/ \equiv
0 288 50	110 - 130 V ~/ \equiv
0 288 51	220 - 250 V ~/ \equiv
0 288 52	415 - 440 V ~

TECHNICAL CHARACTERISTICS

Rated voltage (Uc)	AC : 24 V ; 48 V ; 110 V to 130 V ; 220 V to 250 V ; 415 V to 440 V DC : 24 V ; 48 V ; 110 V to 130 V ; 220 V to 250 V
Operating voltage range (%Uc)	70 to 110
Pick-up consumption (W/VA)	500/500
Response time (ms)	180
Hold consumption (W/VA)	5/5
Opening time (ms)	30
Insulation voltage (kV)	2.5

MOUNTING



Before any intervention, check that the DMX-SP is in the «OFF» position (contacts open), drawn-out position (if necessary) and the discharged spring.

Remove the 4 screws (Phillips head n°1) and the front panel.



ELECTRICAL ACCESSORIES **DMX-SP 4000**

i The mounting operations are identical for the 2 control auxiliaries (shunt trip and undervoltage release) as well as for the closing coil. However, be sure to respect the specific slots as well as the mounting specifications according to the version (drawn-out or fixed).

Insert the 2 lugs into the slots and turn:

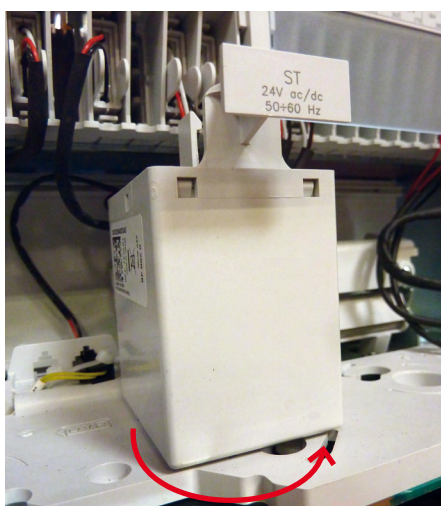
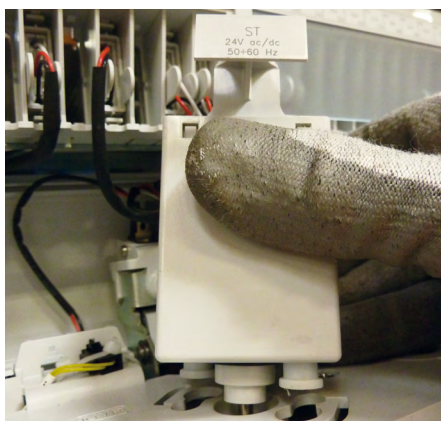

Clip the terminal block and the connector to the specific slots:

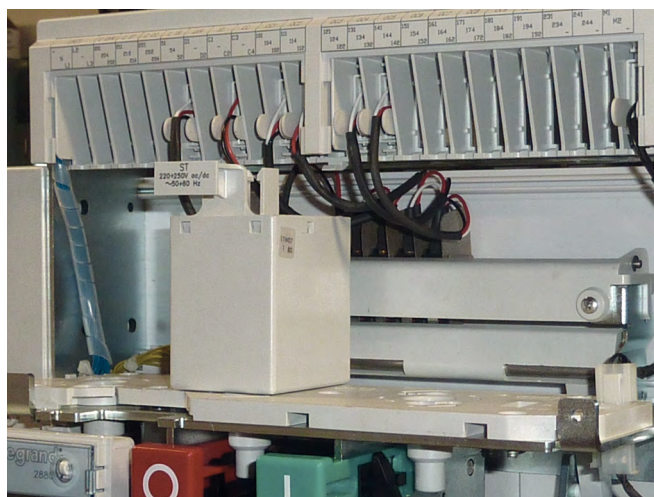

2 - Undervoltage release (Cat.Nos 0 288 55/56/57/58/59)



ST: Shunt Trip
UVR: Undervoltage Release
CC: Closing Coil



The undervoltage release allows instantaneous opening of the DMX-SP by powering off the coil : positive safety.

The electrical signal is given by a NC external contact (for example an emergency stop) and not by the protection unit.

The undervoltage release comes with a connector (male + female) to be inserted into D1 and D2 slots on the DMX-SP terminal block.

The DMX-SP can take only one undervoltage release.

The latter must be in the slot marked «UVR».

Cat.Nos	Operating voltage (Uc)
0 288 55	24 V ~/≡
0 288 56	48 V ~/≡
0 288 57	110-130 V ~/≡
0 288 58	220-250 V ~/≡
0 288 59	415-440 V ~

TECHNICAL CHARACTERISTICS

Rated voltage (Uc)	AC : 24 V ; 48 V ; 110 V to 130 V ; 220 V to 250 V ; 415 V to 440 V DC : 24 V ; 48 V ; 110 V to 130 V ; 220 V to 250 V
Operating voltage range (%Uc)	85 to 110
Pick-up consumption (W/VA)	500/500
Response time (ms)	180
Hold consumption (W/VA)	5/5
Opening time (ms)	60
Insulation voltage (kV)	2.5

ELECTRICAL ACCESSORIES DMX-SP 4000

MOUNTING



Before any intervention, check that the DMX-SP is in the «OFF» position (contacts open), drawn-out position (if necessary) and the discharged spring.

Remove the 4 screws (Phillips head n°1) and the front panel.



The mounting operations are identical for the 2 control auxiliaries (shunt trip and undervoltage release) as well as for the closing coil (see page 52). However, be sure to respect the specific slots as well as the mounting specifications according to the version (drawn-out or fixed).

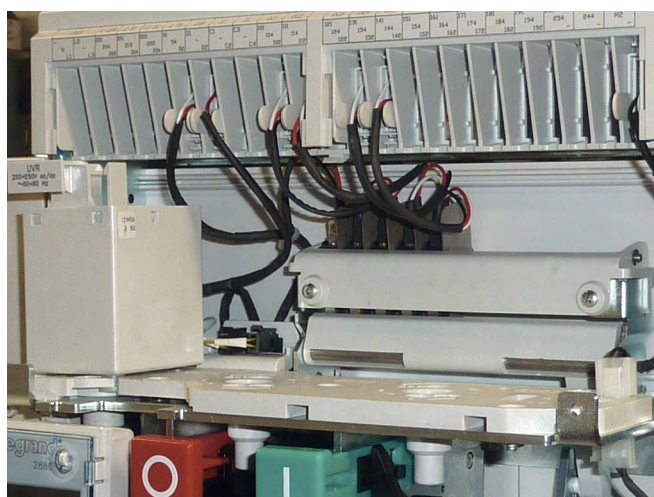

3 - Closing coil (Cat.Nos 0 288 41/42/43/44/45)



ST: Shunt Trip
UVR: Undervoltage Release
CC: Closing Coil



This accessory allows to close the contacts of the DMX-SP by powering on the coil. (provided that all conditions are met: charged coil, key lock in correct position, etc.).

The electrical signal is given by a NO external contact (for example a PLC output) and not by the protection unit.

The closing coil comes with a connector (male + female) to be inserted into slots C3 and C4 on the DMX-SP terminal block.

Only one closing coil can be installed per device. The latter must be placed in the 3rd marked slot.

Cat.Nos	Operating voltage (Uc)
0 288 41	24 V ~/≡
0 288 42	48 V ~/≡
0 288 43	110-130 V ~/≡
0 288 44	220-250 V ~/≡
0 288 45	415-440 V ~

TECHNICAL CHARACTERISTICS

Rated voltage (Uc)	AC: 24 V ; 48 V ; 110 V to 130 V ; 220 V to 250 V ; 415 V to 440 V DC: 24 V ; 48 V ; 110 V to 130 V ; 220 V to 250 V
Operating voltage range (%Uc)	85 to 110
Pick-up consumption (W/VA)	500/500
Response time (ms)	180
Hold consumption (W/VA)	5/5
Opening time (ms)	30
Insulation voltage (kV)	2.5

The closing coil is permanently under rated voltage.

MOUNTING

 Before any intervention, check that the DMX-SP is in the «OFF» position (contacts open), drawn-out position (if necessary) and the discharged spring.

Remove the 4 screws (Phillips head n°1) and the front panel.

 The mounting operations are identical for the 2 control auxiliaries (shunt trip and undervoltage release) as well as for the closing coil (see page 38). However, be sure to respect the specific slots as well as the mounting specifications according to the version (drawn-out or fixed).

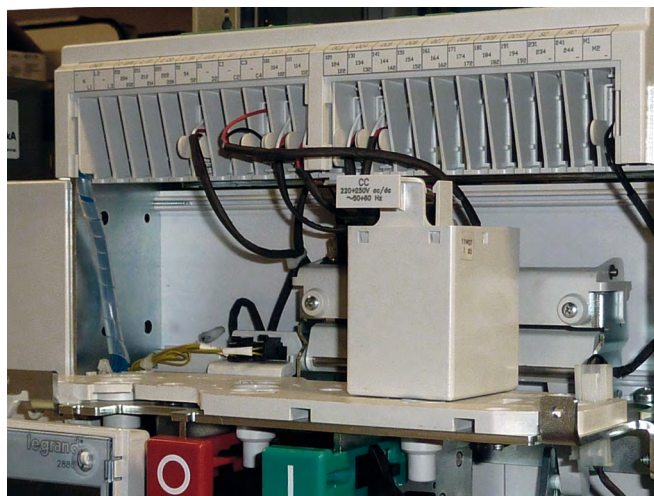

4 - Time-lag module for undervoltage release (Cat.Nos 0 288 62/63)

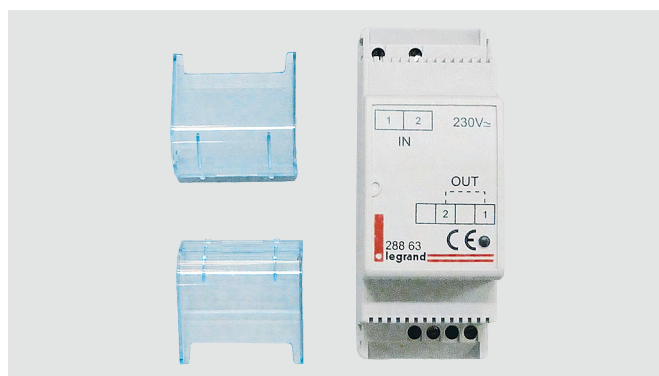

These modules are used to delay the intervention of an undervoltage release installed in a DMX-SP by up to three seconds during a micro-break. These delay modules work with standard undervoltage releases Cat.No 0 281 38 (110 V) and Cat.No 0 281 39 (230 V).

A single module is used to obtain a delay of one second. Connecting three modules in series enables a maximum delay of three seconds.

When using an emergency stop, it must be of NC type, and it should be placed between the output of the last time-lag module and the undervoltage release.

Before turning on the time-lag module, you must ensure that the undervoltage release is connected. Power the module for at least one second to obtain its full operating capacity. Multiply this time by the number of modules installed. Before working on the wiring downstream of the time-lag module, wait a minute after switching off the power supply to avoid any electric shocks.

The protection of this time-lag module must be placed upstream of the DMX-SP where the undervoltage release will be installed.

Cat.Nos	Operating voltage (Uc)
0 288 62	110 V ~ / -
0 288 63	230 V ~ / -

CARACTÉRISTIQUES TECHNIQUES

Rated voltage (Uc)	AC : 110 V / 230 V DC : 110 V / 230 V
Operating voltage range (%Uc)	85 to 110
Pick-up consumption (W/VA)	16,5 (to 110 V)/34,5 (to 230 V)
Delay(s) Uc	1 ⁽¹⁾
Hold consumption (W/VA)	5 (to 110 V)/10 (to 230 V)
Opening operating threshold	0.35 to 0.7 Un
Closing operating threshold	0.85 Un
Operating temperature (°C)	- 10 to + 55

(1) up to 3 modules -1s delay for each module installed

MOUNTING

Example with Cat.No 0 288 63 (identical mounting for Cat.No 0 28862):

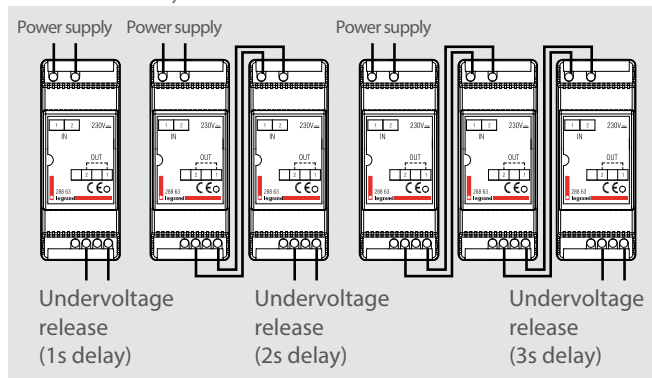

5 - Motor operator (Cat.Nos 0 288 34/35/36/37/38/40)



The motor operator is used to reset the closing spring automatically. Its starting and stopping are automatic if voltage is present at its terminals.

It is preferable to have a constant voltage at the terminals so that the DMX-SP can operate quickly.

The motor operator has an internal protection per fuse. For security matters, the replacement of that fuse must be operated power off.

The motor operator comes with a connector (male + female) to be inserted into M1 and M2 slots on the DMX-SP terminal block.

In parallel with its installation, it is possible to add a control auxiliary (undervoltage release or shunt trip) and a closing coil.

If there is no longer any voltage at the terminals of the motor operator, it is always possible to recharge the spring manually.

Mounting the motor in the circuit breaker :

Cat.Nos	Operating voltage	Fuse type
0 288 34	24 V ~/≡	250 V - 10A T - 5 x 20 mm
0 288 35	48 V ~/≡	250 V - 8A T - 5 x 20 mm
0 288 36	110 - 130 V ~/≡	250 V - 4A T - 5 x 20 mm
0 288 37	220 - 250 V ~/≡	250 V - 2A T - 5 x 20 mm
0 288 38	415 - 440 V ~	500 V - 1A T - 6.3 x 32 mm
0 288 40	480 V ~/≡	500 V - 0,63A T - 6.3 x 32 mm

TECHNICAL CHARACTERISTICS

Rated voltage (Uc)	AC: 24 V ; 48 V ; 110 V to 130 V ; 220 V to 250 V ; 415 V to 440 V DC: 24 V ; 48 V ; 110 V to 130 V ; 220 V to 250 V
Operating voltage range (%Uc)	85 to 110
Max. dissipated power (W/VA)	240/240
Max. current for 80ms	(2 ÷ 3) x I _n
Charging time (s)	7
Maximum operating frequency (cycles/min)	1

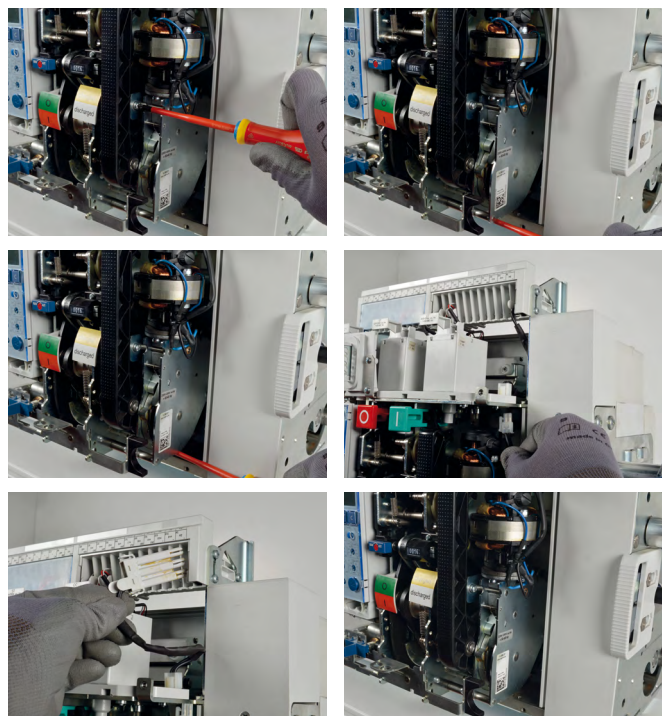

6 - Signalling contact for «inserted/test/drawn-out» position (Cat.No 0 288 13)

These contacts allow you to remotely report the position of a draw-out version DMX-SP in its base: «inserted», «test» or «drawn-out».

Each contact has a specific function that cannot be modified. The block has 9 contacts: 3 for the presence of DMX-SP in the base («drawn-out»), 3 for the «test» position and 3 for the «inserted» position.

These contacts are the changeover type (NO-NF) with dry contact (potential-free).

Only one contact block can be installed per DMX-SP draw-out version.

The electrical connection is made with insulated 6.3 mm Faston lugs (the contact block is delivered with 27 insulated lugs).

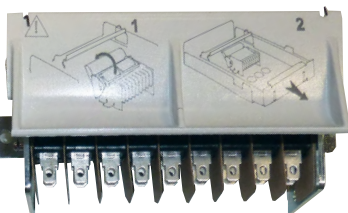

TECHNICAL CHARACTERISTICS

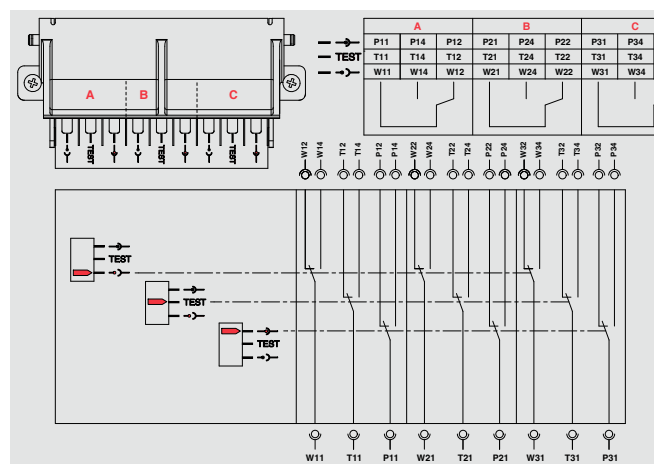

- Max. voltage: 250 Vac/dc
- Rated current:
 - 16 A from 125 Vac to 250 Vac
 - 0.6 A under 125 Vdc
 - 0.3 A under 250 Vdc

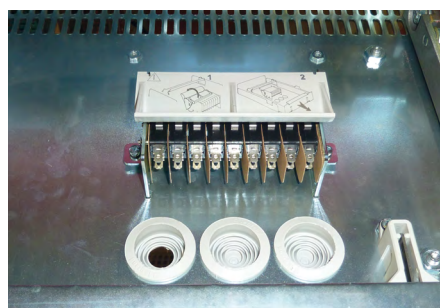

The contact block is mounted on the base

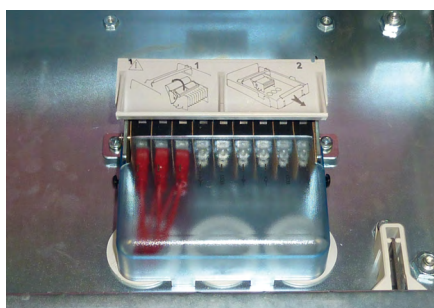

The insulation cover ensures the protection of the terminals



The plate mounted under the DMX-SP activates the contacts during the inserting and drawing-out operations

i When handling the cart without the DMX-SP, it is necessary to tilt the cover of the contact block before any extraction

! When replacing a drawn-out product, do not forget to collect the plastic plate located under the DMX-SP.



7 - «Ready to close» with charged spring (Cat.No 0 288 14)



This contact block provides feedback of two distinct types of information:

- Device ready to close (RC): the contact is closed when the spring is charged, as long as there is no fault detected on the circuit breaker and all safety systems allowing closure are inactive.
- Spring charged (SC): the contact is closed when the spring is fully charged (electrically or manually).

When setting-up this contact block, verify that the two lugs are at the right place.

These contacts are volt-free changeover (NO) contacts.

On the DMX-SP terminal block, the «ready to close» contact is connected to slot «RC» at terminals 241/244 and the «spring charged» contact to slot «SC» at terminals 231/234.

TECHNICAL CHARACTERISTICS

- Max. voltage: 250 Vac/dc
- Rated current:
 - 16 A from 125 Vac to 250 Vac
 - 0.6 A under 125 Vdc
 - 0.3 A under 250 Vdc

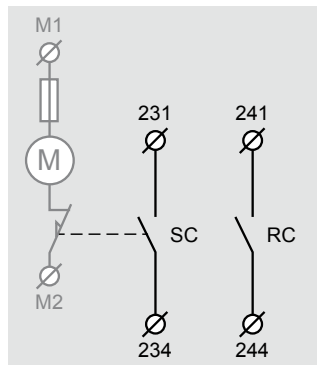

RC = « Ready to Close »
SC = « Springs Charged »

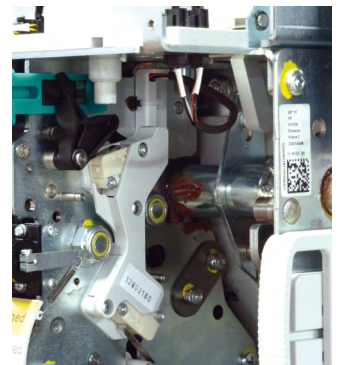

Contact block mounted inside the DMX-SP

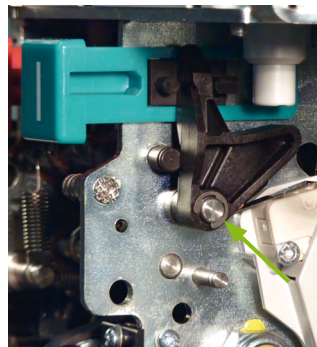

RC contact lug

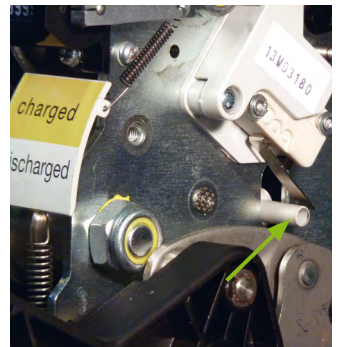

SC contact lug

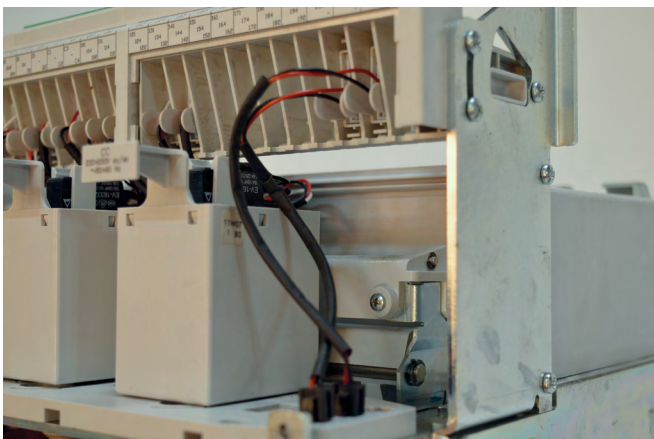
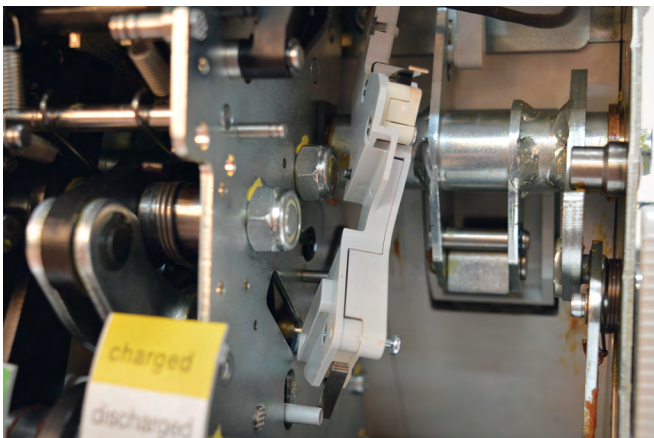

8 - Auxiliary contact module (Cat.Nos 0 288 15)

The auxiliary contacts are used to signal the position of the main DMX-SP contacts.

These contacts are changeover (NO/NC) dry contacts (free potential). When the DMX-SP terminals are open, the contact is made between terminals 1x1 and 1x2.

All DMX-SP and DMX-SP-I are delivered with four pre-installed auxiliary contacts. It is possible to add six additional contacts for a total of ten auxiliary contacts. These contacts are delivered with their connector (male + female) and a lateral shield for better insulation.

These auxiliary contacts are mounted on the contact block supplied with the circuit breakers. It is located behind the coils. Before dismantling the contact block, it is necessary to disconnect the OC contact located on the left side of the block as well as the 4 other contacts. After unscrewing the block and removing the Truarc ring, the additional contact is inserted by sliding it onto the 2 axis.

CONTACTS		POSITION ON THE DMX-SP TERMINAL BLOCK	TERMINALS
Pre-installed	1	OC1	101/102/104
	2	OC2	111/112/114
Optionnal	3	OC3	121/122/124
	4	OC4	131/132/134
	5	OC5	141/142/144
	6	OC6	151/152/154
	7	OC7	161/162/164
	8	OC8	171/172/174
	9	OC9	181/182/184
	10	OC10	191/192/194

TECHNICAL CHARACTERISTICS

- Max. voltage: 250 Vac/dc
- Rated current :
 - 16 A from 125 Vac to 250 Vac
 - 0.6 A under 125 Vdc
 - 0.3 A under 250 Vdc

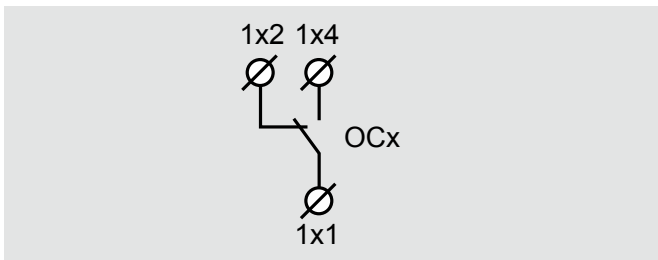

i OC : Open Close → auxiliary contact state

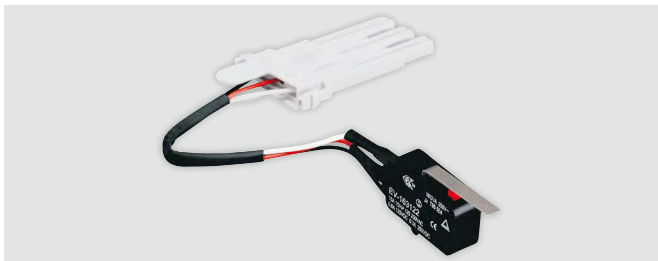

Four pre-installed auxiliary contacts and one optional auxiliary contact.

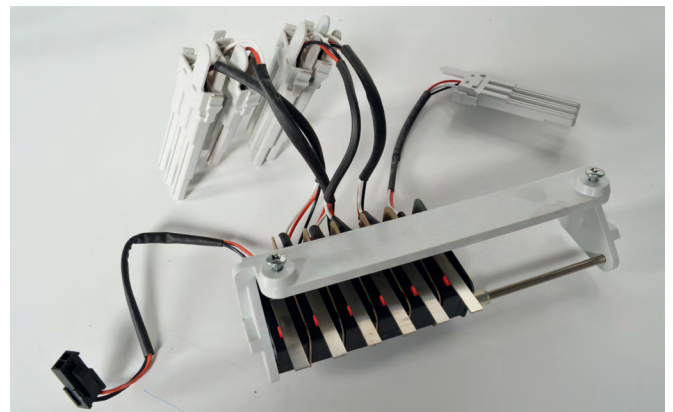
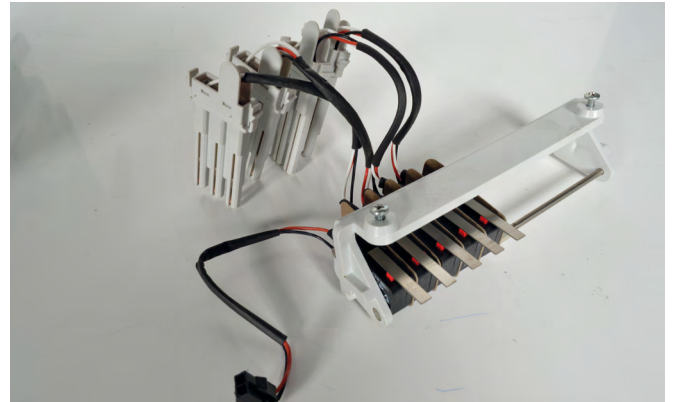
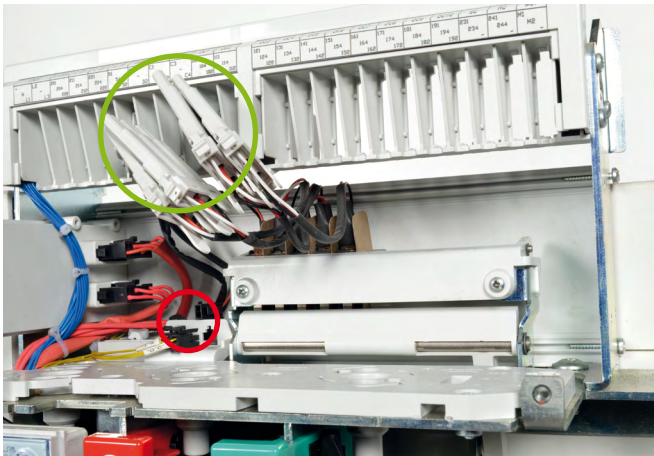
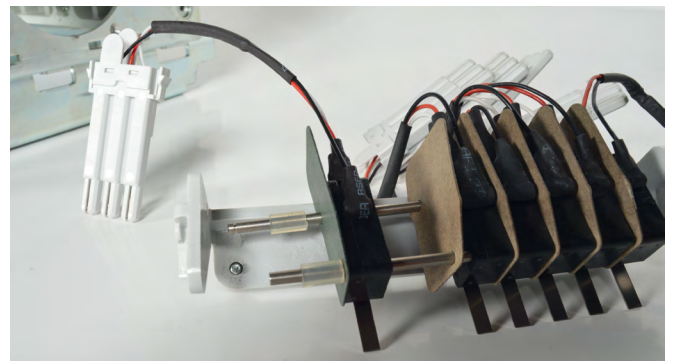

Before and after the installation of a contact.

9 - Contact for signalling trip or coils status (Cat.Nos 0 288 16)

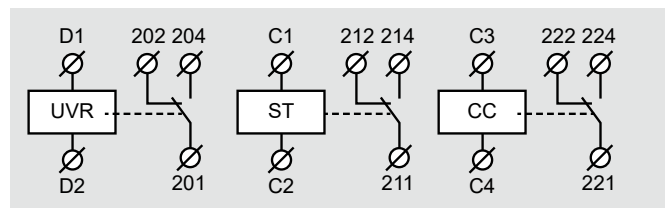
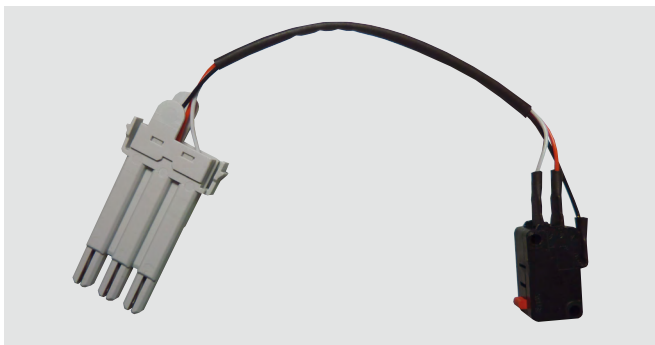

This contact is used to signal the status of the various control auxiliaries and coils (shunt trip, undervoltage release and closing coil) installed in the DMX-SP.

These contacts are changeover (NO/NC) dry contacts (free potential).

Only one contact can be installed per trip unit or coil.

This contact is delivered with its connector (male + female).

Connector on the DMX-SP terminal block:

- C UVR: 201/202/204 for the undervoltage release.
- C ST: 211/212/214 for the shunt trip.
- C CC: 221/222/224 for the closing coil.

TECHNICAL CHARACTERISTICS

- Max. voltage: 250 Vac/dc
- Rated current :
 - 16 A from 125 Vac to 250 Vac
 - 0.6 A under 125 Vdc
 - 0.3 A under 250 Vdc

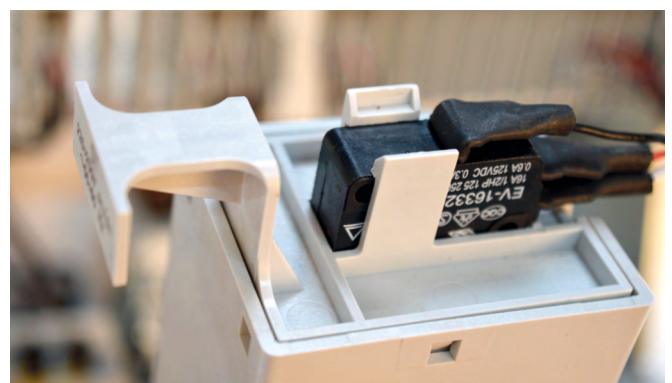
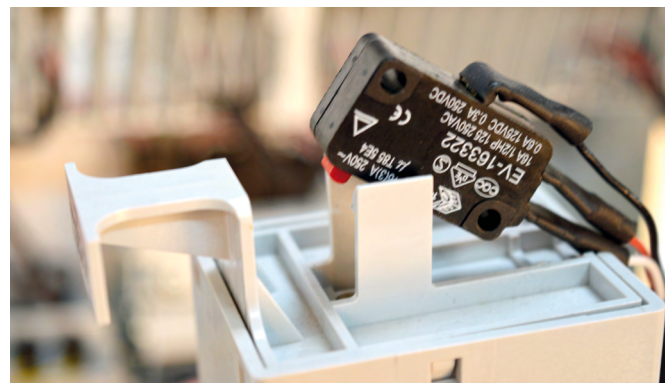

10 - Power supply module EMS CX³

The power supply Cat.No 4 149 45 integrate the modular system EMS CX³ for the energy monitoring within the electric boards. It is mandatory to use this supply, dédié to the EMS CX³. This module distributes power via the rail and/or the communicating cables.

TECHNICAL CHARACTERISTICS

- Display: none
- Power supply: primary 95 to 250 Vac secondary 12Vcc 0.5A
- Settings: none
- Addressing: none
- Connexion:
 - power supply via screw terminals;
 - power distribution via rail or specific cables.
- Mounting: on DIN rail
- Dimensions: 1 module
- Supplied with a white cable for galvanic separation.



For more information, see technical sheet.

The number of power supply 4 149 45 in an EMX CX3 system depends on the power required for the proper operation of the module. A power supply module can supply up to 500 mA. If the installation requires a more power, a new power supply module must be envisaged. The same BUS EMS CX must not exceed 1.5 A: i.e. 3 power supply modules maximum. The total power supply modules allowed under a power supply depends on the sum of their consumption.



The length of all cables of the EMS system must not exceed 3m.

1 EMS CX³ system
1 power supply module

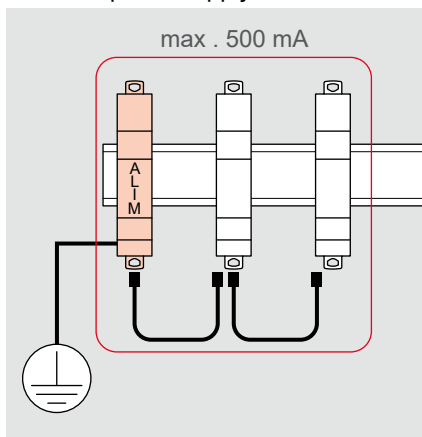

1 EMS CX³ system
2 power supply modules

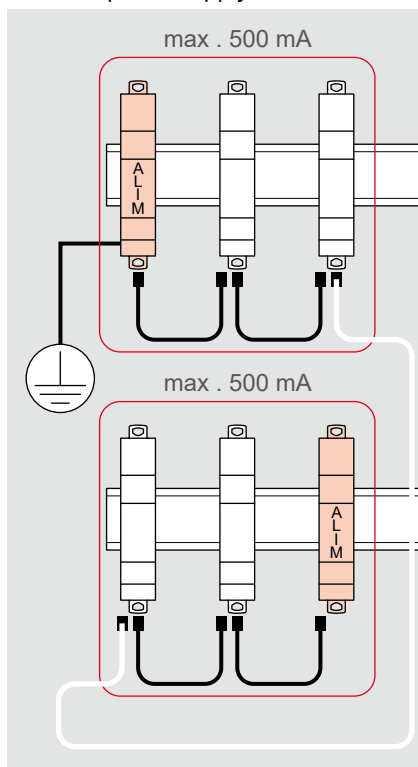

1 EMS CX³ system
3 power supply modules

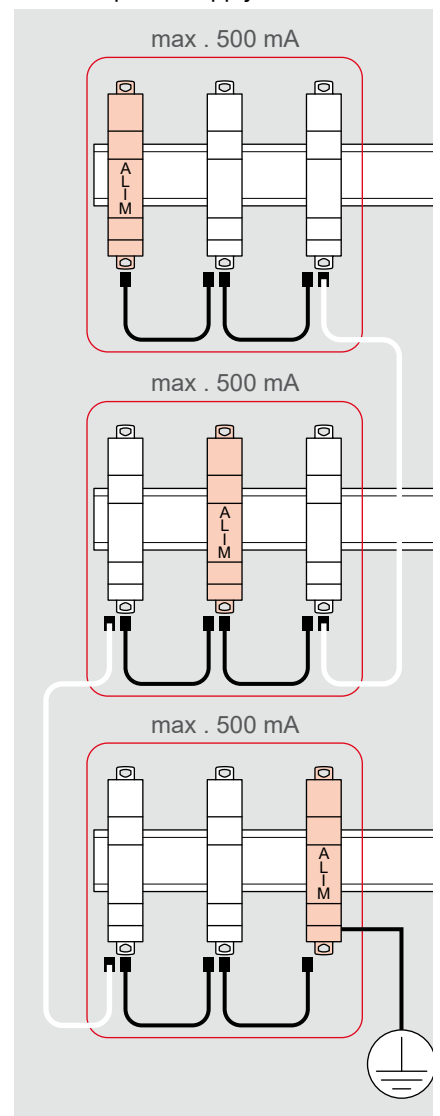

i In the case of 1 or 2 power supplies, they must be installed to each end of the EMS CX³ system.

In the case 3 power supplies, 2 must be installed to each end of the EMS CX³ system, and the 3rd in the middle.

Beware, each set must be linked by a white cable.

i 2 power supplies cannot be installed on the same communicating rail.

! Each set composed of «one power supply module and its EMS CX³ modules» must be separated by a special link including mandatorily a white cable (delivered with each power supply module).

! In case of many power supply modules in the same system, only one power supply module must be earthed.

CONNECTION

- Power supply of the module :

Screw connection at the bottom of the module.



i To protect the power supply module, see indications on the product technical sheet, available on the e-catalog.

- Le BUS EMS CX³ :

2 solutions are possible for the connection to the BUS:



By the back of the modules via communicating rails Cat.Nos 4 149 01/02/03

! The modules cannot slide on the rail once they are in place.

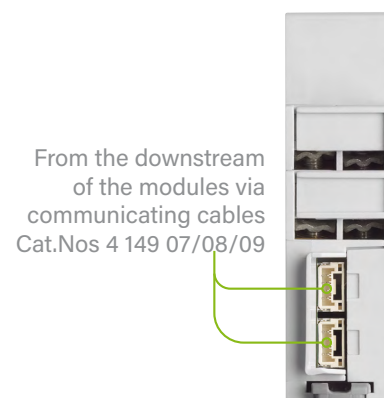

From the downstream of the modules via communicating cables Cat.Nos 4 149 07/08/09

i The EMS CX³ bus connection specifications are common to all EMS CX³ products.
 For more details, and to know the consumer of all the modules EMS CX³, see the technical sheet, available on the e-catalog.

DMX-SP 4000 ELECTRICAL ACCESSORIES

Protection units can be connected to EMS CX³ system with connection cables Cat.No 4 149 07/08/09 and connector Cat.No 4 149 10.

- 4 149 07: EMS connection cable 250 mm length
- 4 149 08: EMS connection cable 500 mm length
- 4 149 09: EMS connection cable 1000 mm length

 The length of all cables of the EMS system must not exceed 3m.

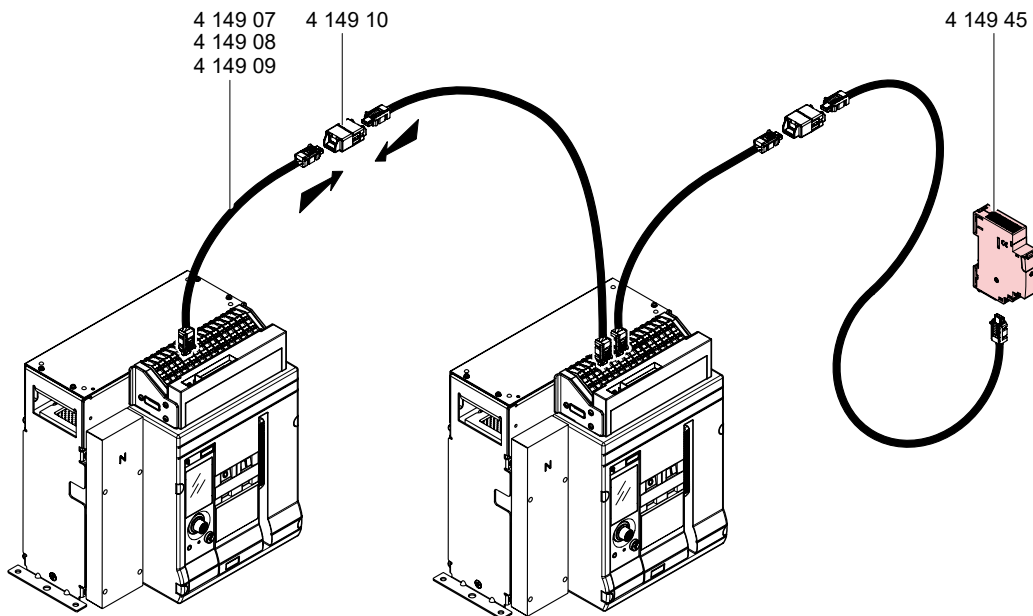

 A power supply module can supply up to 500 mA. A calculation of the consumption must be carried out to ensure proper operation of the system.

TABLE OF CONSUMPTIONS

Cat.Nos	Designation	Maximum consumption
0 283 00	MP2.10 protection unit without measure	55 mA
0 283 01	MP2.10 protection unit with measure	69 mA
0 283 02	MP4.10 protection unit without measure	62,5 mA
0 283 03	MP4.10 protection unit with measure	80 mA

11 - Fault contact (pre-installed on the circuit breaker)

The fault contact allows remote opening of the circuit breaker following an order given by the protection unit (fault or test).

On the DMX-SP 4000, it must be ordered at the same time as the circuit breaker. It cannot be installed by the client, therefore it is factory assembled. It is not physically accessible. On the terminal block this contact is connected to the slot identified as «CTR» on terminals 51/52/54.

There is only one fault contact per DMX-SP circuit breaker.

The fault contact can be rendered non-maintained if the reset button is set to AUTO. If this is the case, the fault contact will switch for a time between 15 and 20 ms.

This contact is changeover (NO/NC) dry contact (free potential).

In a normal, non-tripped state, terminals 51 and 52 are conductive.

TECHNICAL CHARACTERISTICS

- Max. voltage: 250 Vac/dc
- Rated current :
 - 6 A from 125 Vac to 250 Vac
 - 0.6 A under 125 Vdc
 - 0.3 A under 250 Vdc

i DMX-SP-I trip free switches cannot be equipped with a CTR fault contact.

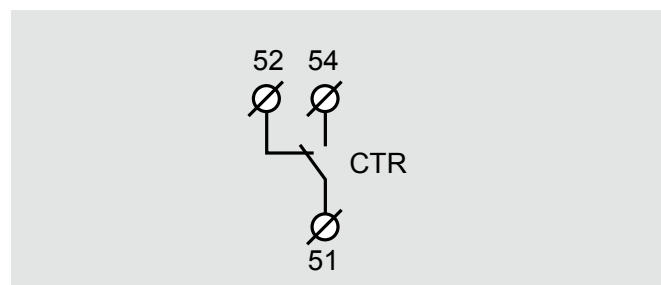

i CTR: Contact Trip → fault contact

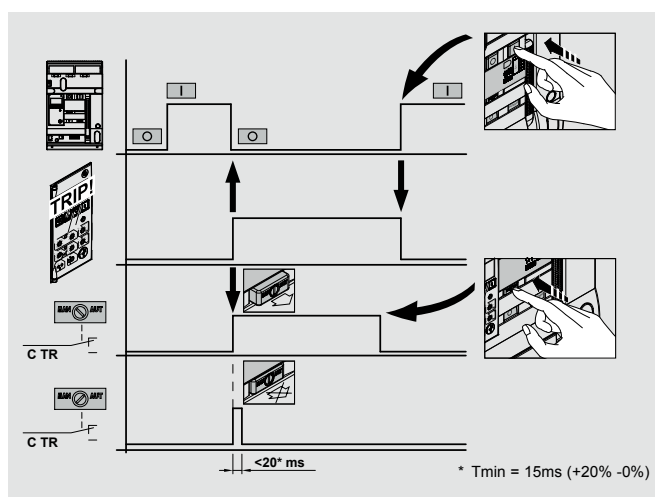
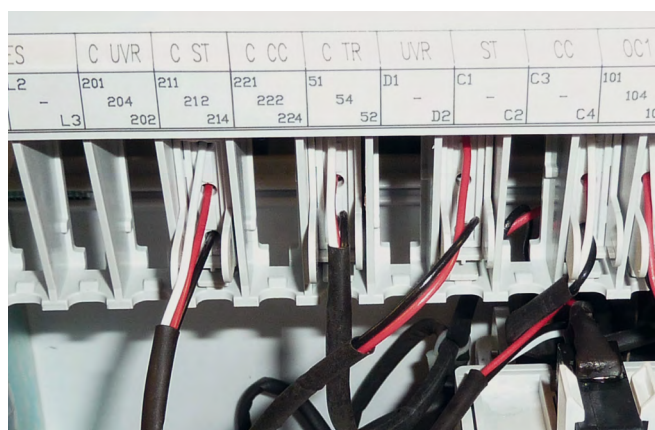

12 - External neutral & earth leakage protection (Cat.Nos 0 281 98)

The use of this accessory requires a special adaptation of the circuit breaker. It must be ordered with this option for factory assembly because it cannot be added afterwards.

This coil allows the following functions :

- Protection against neutral overload when the neutral is not cut by the DMX-SP
- Protection of the earth exclusively with Ig protection units.

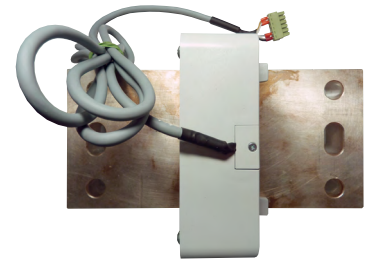

EXTERNAL NEUTRAL PROTECTION

This option is only available with 3-pole devices.

The coil will be connected to the neutral, at the same level as the DMX-SP.

For a protection unit with energy meter, a neutral voltage socket must be connected to the DMX-SP terminal block.

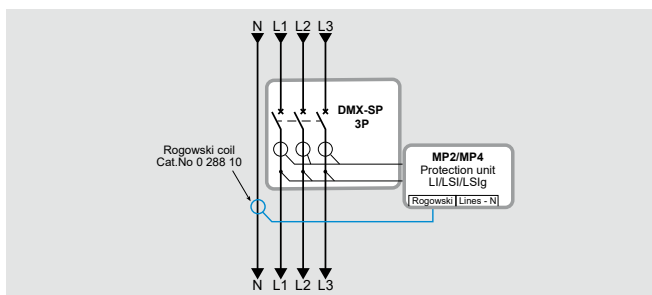

The direction of current flow in the Rogowski coil must be respected (see the installation instructions).

The terminal block supplied with the coil must be connected to the terminal block on the circuit board of the protection unit. The coil cable should be as far away as possible from electromagnetic interference sources (transformers, etc.) and power conductors. Check that the protection unit is correctly set.

EARTH LEAKAGE PROTECTION

The «earth leakage protection» function is different from a «residual current protection».

As a reminder, the minimum setting of the earth leakage protection is $I_g = 0.2 \times I_n$

The principle of this protection is RS (Residual Sensing). The earth fault current is calculated using the vector sum of the currents of the three phases. The SGR (Source Ground Return) and ZS (Zero Sequence) protections are not usable.

This option is available for 3-pole DMX-SP with uncut neutral, equipped with protection units with energy meter.

The Rogowski coil will be connected to the neutral, at the same level as the DMX-SP.

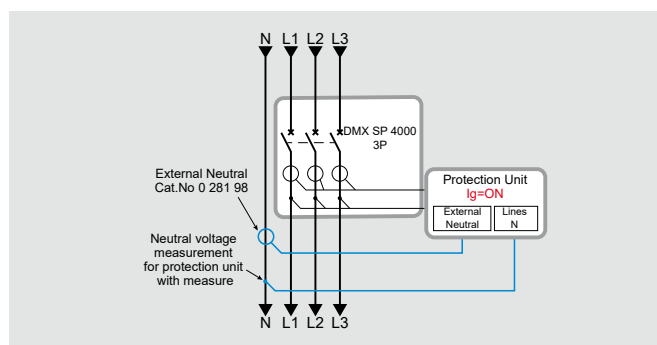

For a protection unit with measure, a neutral voltage socket must be connected to the DMX-SP terminal block.

The external neutral overload protection is activated by default, but can be deactivated later.

The direction of flow in the Rogowski coil must be respected (see the installation instructions).

The terminal block supplied with the coil must be connected to the terminal block on the circuit board of the protection unit. The coil cable should be kept as far away as possible from electromagnetic interference sources (transformers, etc.) and power conductors.

Check that the protection unit is correctly set.



The identification number of external neutral must be identical to the series number of the circuit breaker. If it is not the case, it is not possible to un-plug the DMX-SP, please contact you Legrand interlocutor.

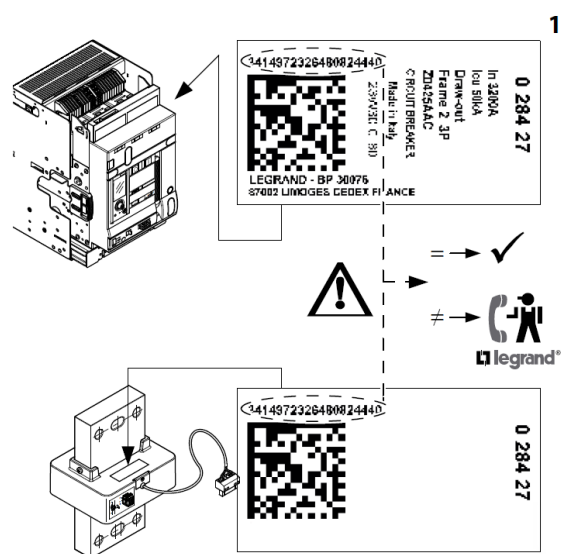

11 - Terminal block layout and accessory location

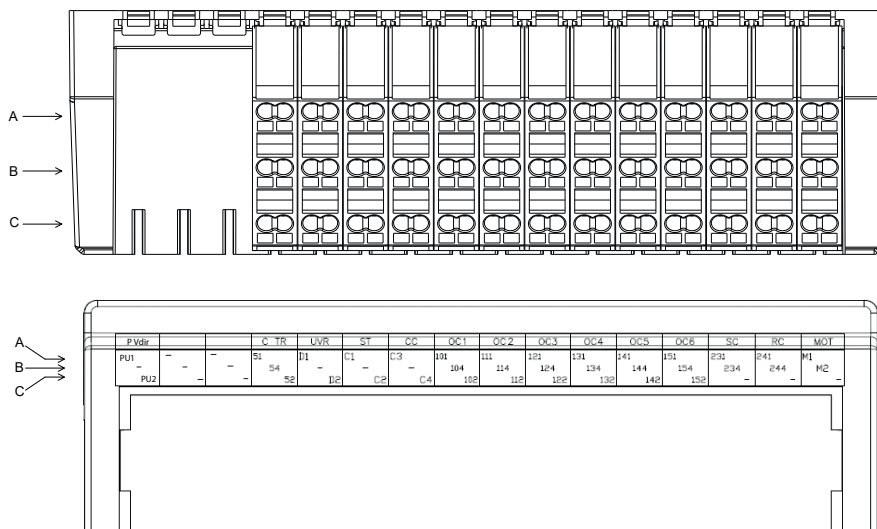

- Automatic spring-cage terminals
 - Insert a flat screwdriver (3 mm): the spring opens.
 - Insert the cable.
 - Remove the screwdriver: the spring automatically blocks the cable.

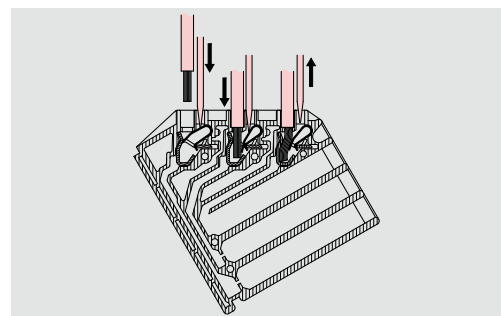

A spring-cage terminal accepts a maximum cross-section of 2,5 mm²/ cable and a maximum number of 2 cables. It is also possible to insert 2 cables of different sections while respecting the tolerances detailed below.

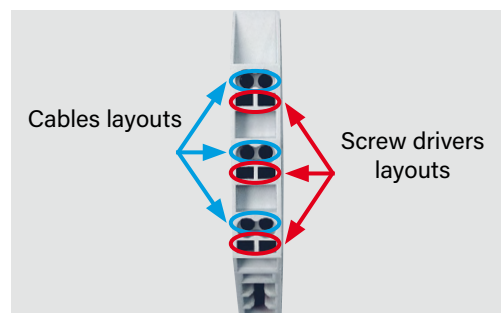

• Recommended cross-sections

Rigid cable		1 to 2,5 mm ²
Flexible cable without ferrule		1 to 2,5 mm ²
Flexible cable with flanged end cap		1 to 1,5 mm ²
Flexible cable with collarless endcap		2,5 mm ²

• Recommended stripping length (optimal: 11 mm)

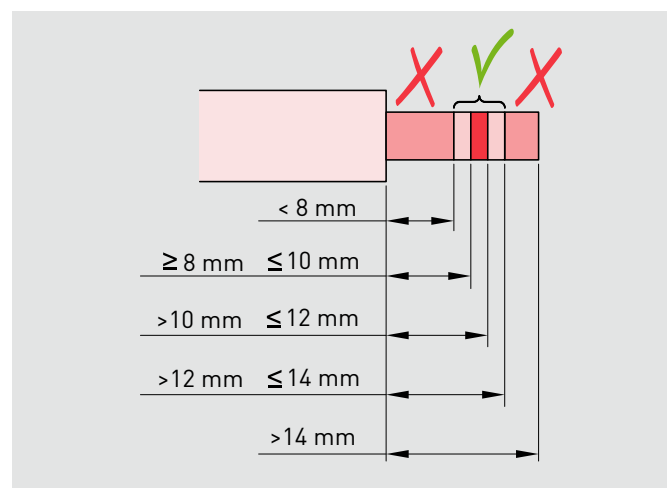

• Terminals concerning the protection unit

Draw-out version: wire the circuit breaker in the fully withdrawable position

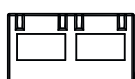
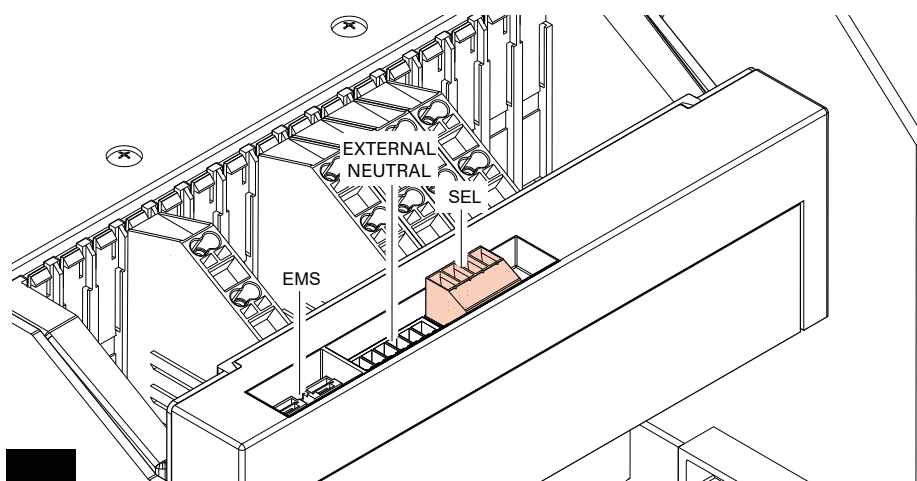

EMS

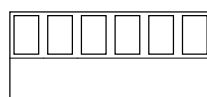

EXTERNAL NEUTRAL
0 281 25 (6-WAY TERMINAL BLOCK)

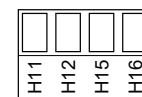

SEL :
H11 - H12 SEL_IN
H15 - H16 SEL_OUT

14 - Wiring diagrams

3P CIRCUIT BREAKER WITH ENERGY METER AND 3P + EXTERNAL NEUTRAL WITH ENERGY METER

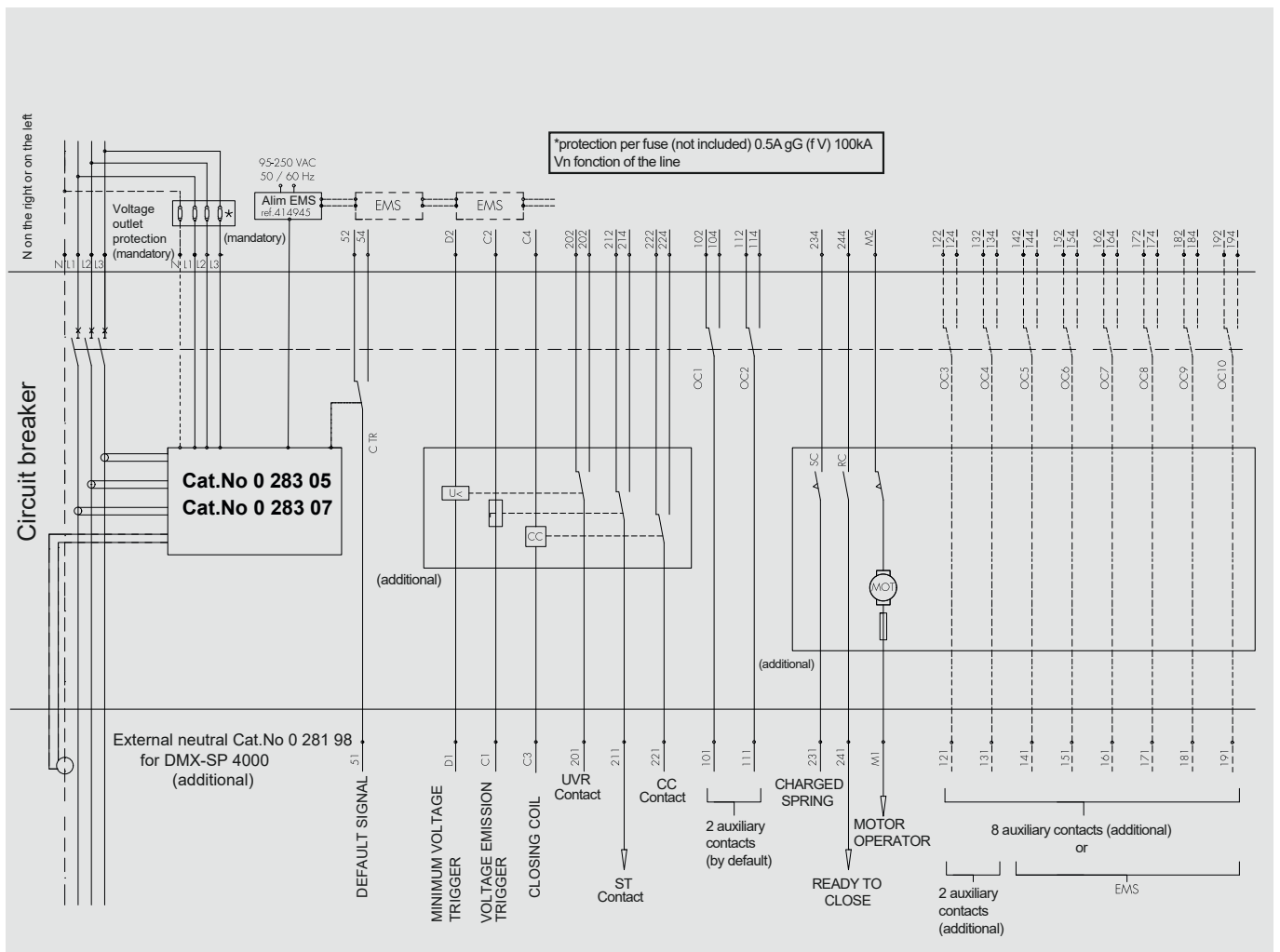

4P CIRCUIT BREAKER WITH ENERGY METER

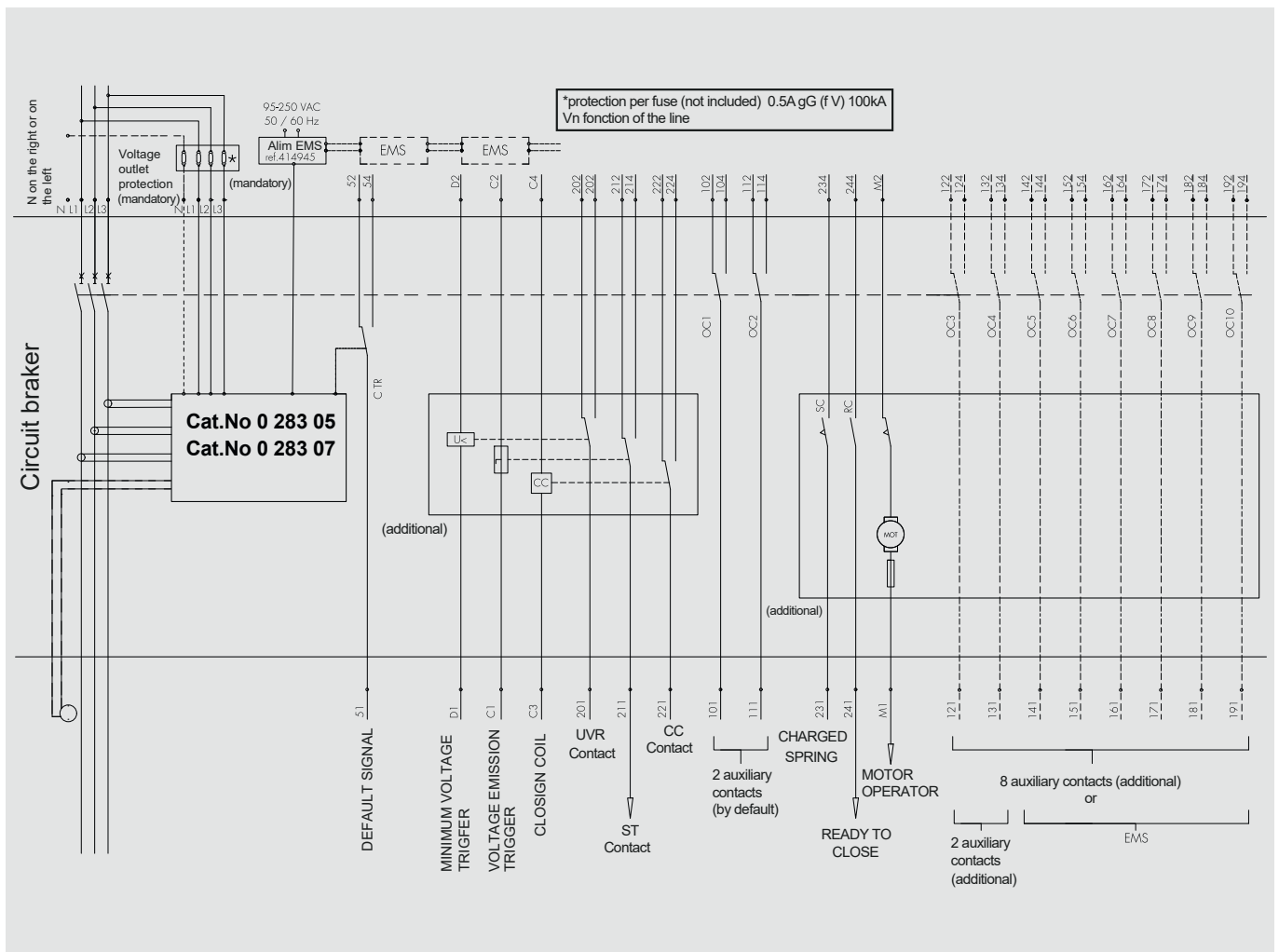

ELECTRICAL ACCESSORIES DMX-SP 4000

3P CIRCUIT BREAKER AND 3P + EXTERNAL NEUTRAL

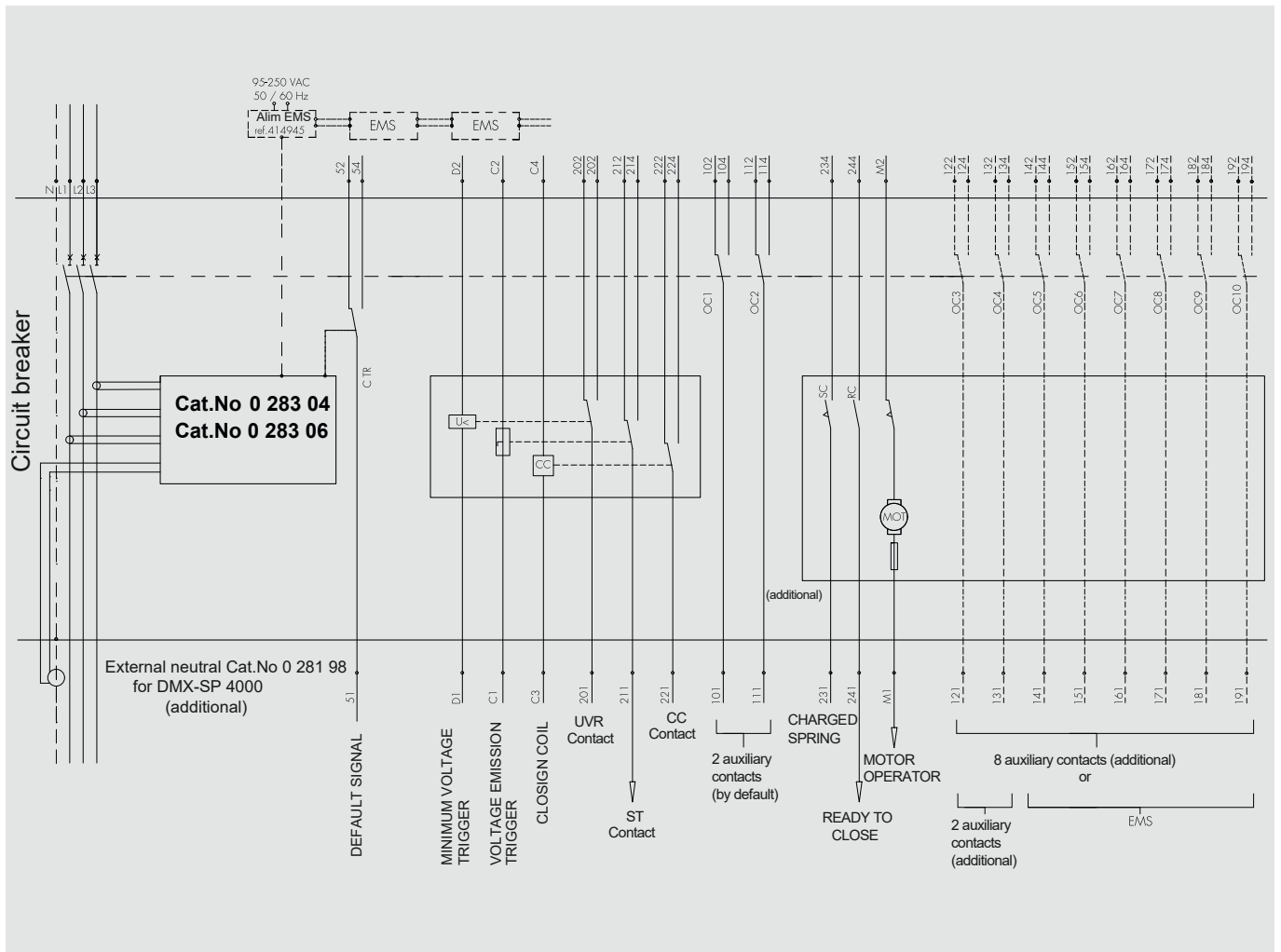

4P CIRCUIT BREAKER

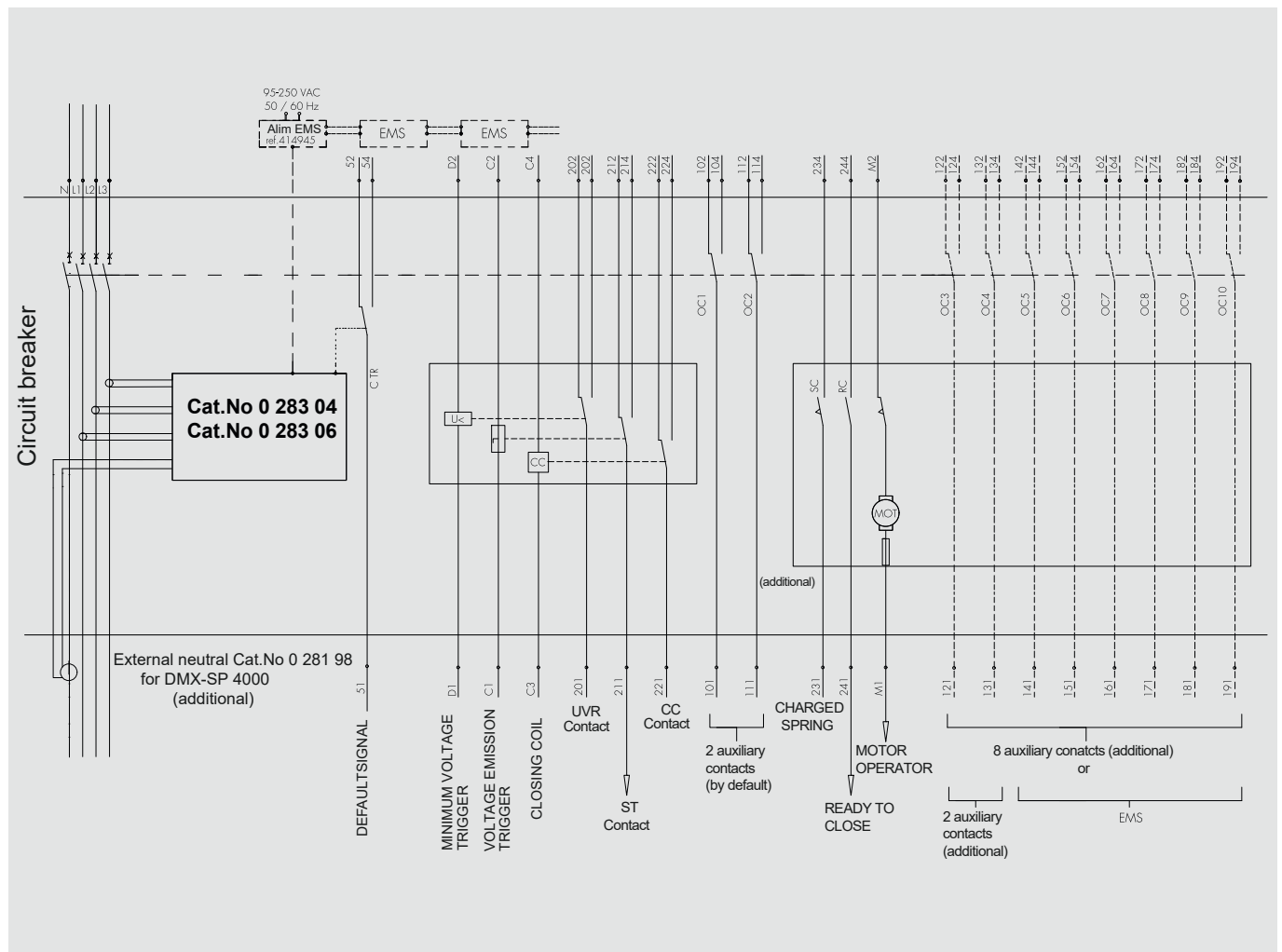

3P TRIP FREE SWITCH

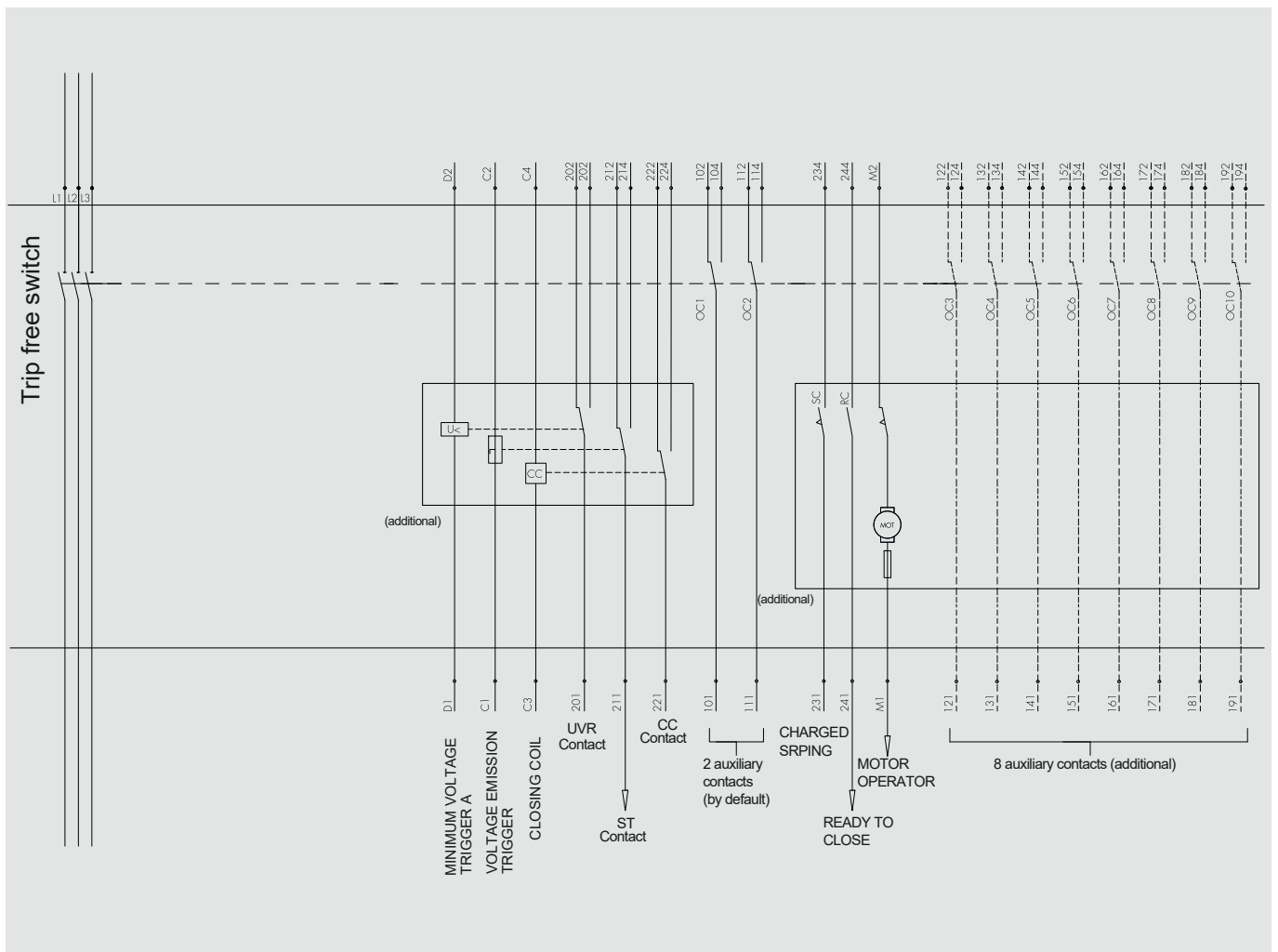

4P TRIP FREE SWITCH SWITCH

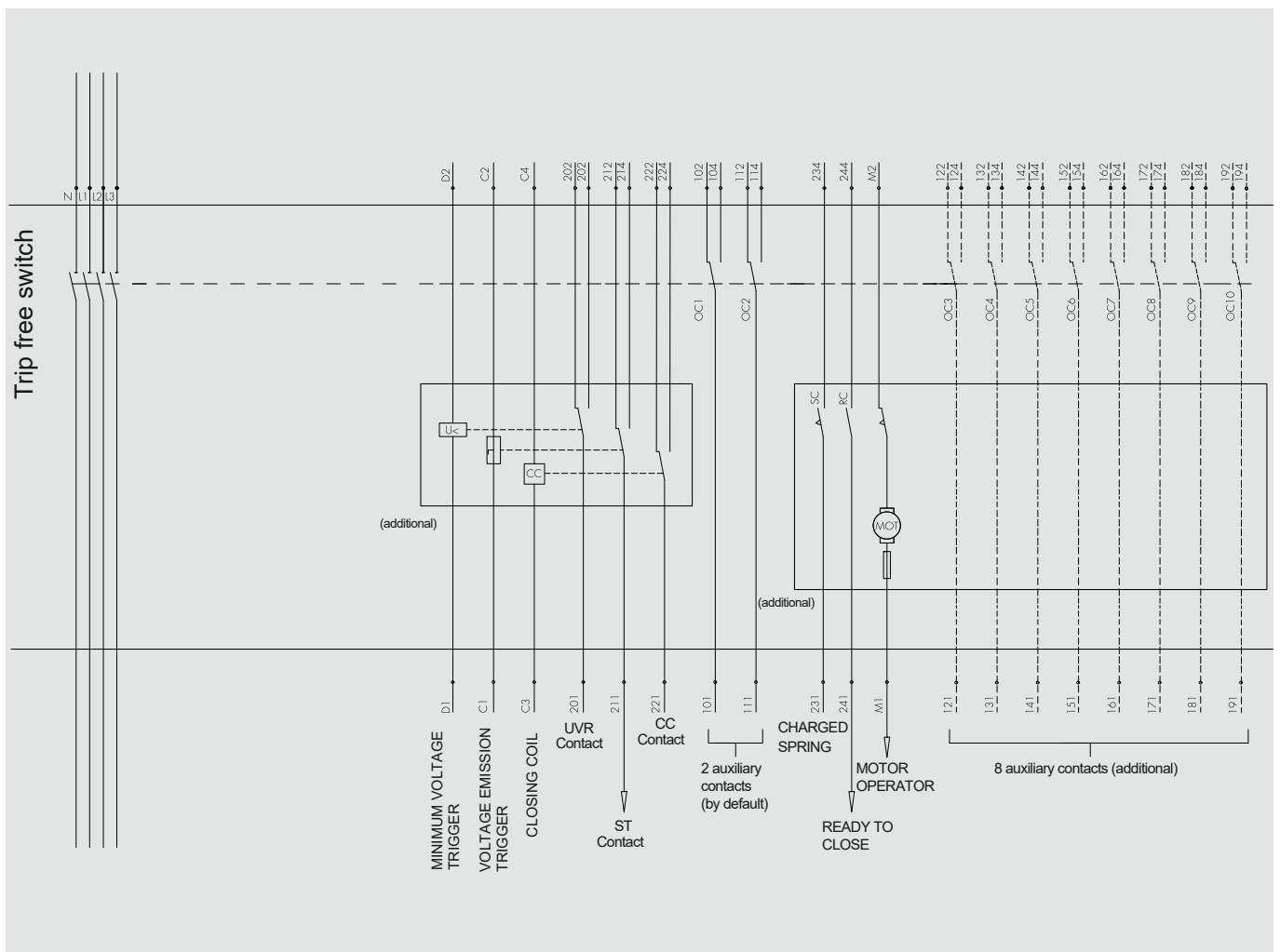

DMX-SP 2500

MECHANICAL ACCESSORIES

1. Key locking in « open » position (Cat.Nos. 4 238 80/81/82/83)
2. Key locking in « drawn-out » position (Cat.Nos 4 238 80/83)
3. Door locking (Cat.No. 0 281 84)
4. Mechanical counter (Cat.No. 0 281 88)
5. Inserted/test/drawn-out lock button (Cat.Nos 6 696 08)
6. Rating mis-insertion device (Cat.No 0 281 89)
7. Base for Draw-out version 3P and 4P (Cat.Nos. 6 696 10/11)
8. Mechanical interlock (Cat.No 0 281 90)
9. Interlocking cables (Cat.Nos. 0 289 17/18/20/21/22/23/24/25)
10. Insulation shields (Cat.Nos 6 696 00/01/02/03)

1 - Key locking in « open » position

The barrels in the following table must be associated with a support Cat.Nos 0 281 91.

Key cylinder and flat key with random marking	4 238 80
Key cylinder and flat key with EL43525 marking	4 238 81
Key cylinder and flat key with EL43363 marking	4 238 82
Key cylinder and star key with random marking	4 238 83

Example Cat.Nos 0 281 91 + 4 238 83



A lock in the “open” position prevents the DMX-SP from closing. It can be installed on fixed or drawn-out devices, circuit breakers or switches.

There are two types of locking: with a flat key (type RONIS) or with a star key (type PROFALUX).

To lock the DMX-SP, simply press the OFF button and turn the key 1/4 turn clockwise.

To unlock the DMX-SP, simply turn the key 1/4 turn counterclockwise and the OFF button will return to its position. In the locked position, the key is free. It is then possible to lock the unit by removing it.

In the unlocked position, the key cannot be removed.

It is possible to order specific barrels or additional keys specifying the barrel number:

- Flat key: ABA90GEL6149
- Star key: HBA90GPS6149.

However, it is necessary to order a keylock support Cat.No 0 281 91 in order to have the different fixing accessories.

MOUNTING

 Before any intervention, check that the DMX-SP is in the «OFF» position (contacts open), drawn-out position (if necessary) and the discharged spring.

Remove the 4 screws (Phillips head n°1) and the front panel.

Remove the lock location on the back of the front panel using a 23 mm drill bit (or other tool).

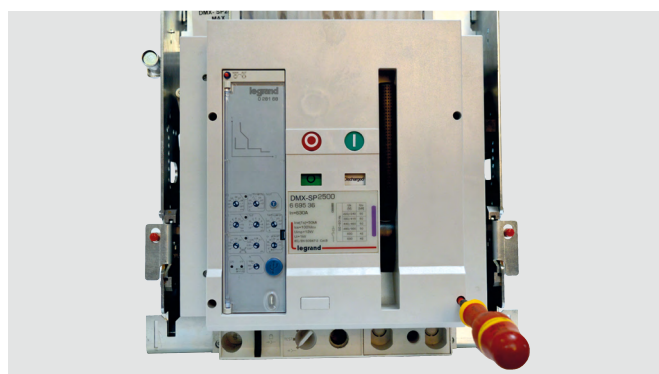

Insert the supplied plastic cam and secure it with the metal nut using a 16 mm flat key.

 Position the key vertically during this process.

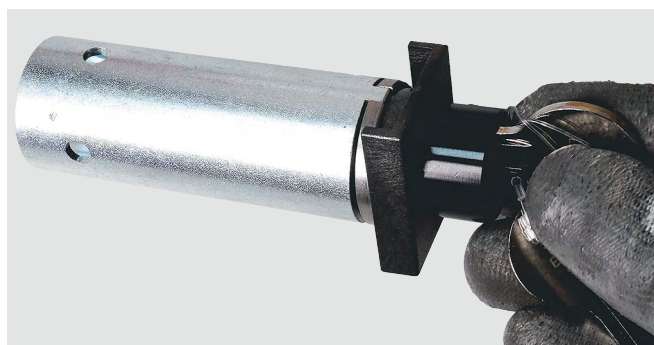

Insert the supplied plastic cam and secure it with the metal nut using a 16 mm flat key (tightening torque 4 Nm).

DMX-SP 2500 MECHANICAL ACCESSORIES

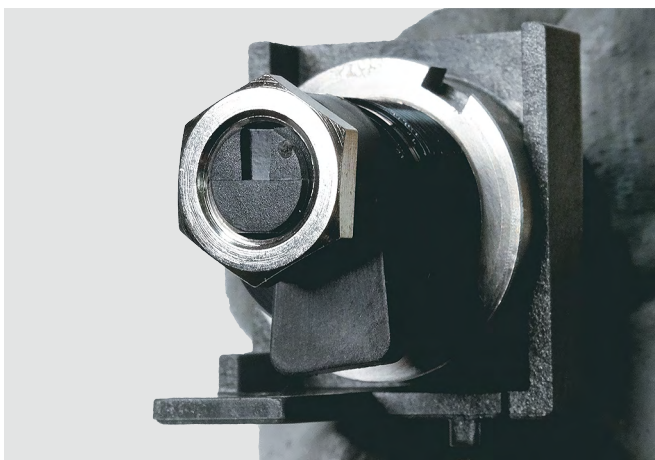

Secure the lock with the supplied screw using a tool with Philipps head n°1 (tightening torque 3 Nm).



Position the lock over the «OFF» button of the DMX-SP in the dedicated slot.

Slot

Fixing hole

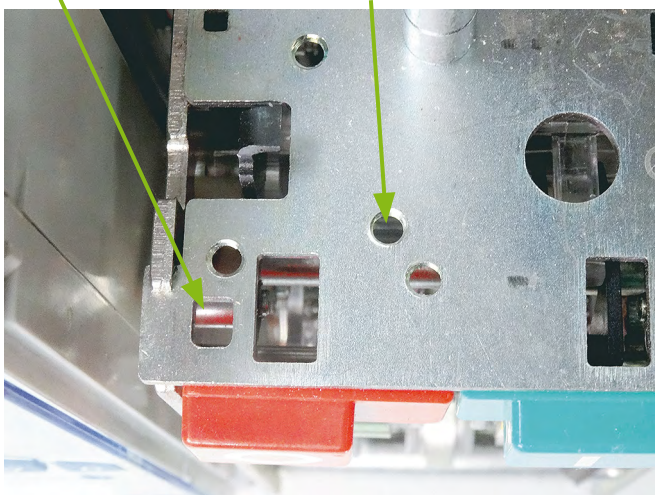

Perform two operating tests:

- Press the «OFF» button.
- Hold this button while turning the key 1/4 turn clockwise.
- Check that the key can be removed and that the «OFF» button remains in the pressed position.
- After recharging the spring, check the correct operation of the accessory by trying to close the circuit breaker (press button I) → impossible



Normal operation (not locked): I cannot remove the key, it is in the horizontal position.

Locked operation: I can remove the key, it is in the vertical position.



Position the key horizontally during this process.

Put back in place the plastic cover of the terminal block, then the front panel using the 4 screws (Phillips head n°1, tightening torque 1 Nm).

Re-insert the DMX-SP if necessary.

2 - Key locking in « drawn-out » position (Cat.Nos 4 238 80/83)

The barrels in the following table must be associated with a support Cat.Nos 0 281 91.

Key cylinder and flat key with random marking	4 238 80
Key cylinder and star key with random marking	4 238 83

Example Cat.Nos 0 281 91 + 4 238 83

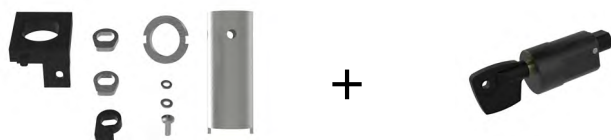

This accessory allows locking in the «drawn-out» position. The design of this accessory prevents locking in the «inserted» position.

To lock the DMX-SP in the «drawn-out» position, turn the key 1/4 turn to the right after making sure that the handle is removed from the plug-in system and that the slot is closed.

In the locked position, the key is free. It is then possible to lock the device by removing it.

To unlock the DMX-SP, so that it can be inserted, simply turn the key 1/4 turn to the left, releasing the locking system for the handle.

There are two types of locks:

- Flat key (RONIS type)
- Star key (type PROFALUX)

It is possible to order specific locks or additional keys by specifying the barrel number

- Flat key: ABA90GEL6149
- Star key: HBA90GPS6149

However, it is necessary to order a locking kit in order to have the different fixing accessories.

MOUNTING



Before any intervention, check that the DMX-SP is in the «OFF» position (contacts open), drawn-out position (if necessary) and the discharged spring.

Remove the 4 screws (Phillips head n°1) and the front panel.

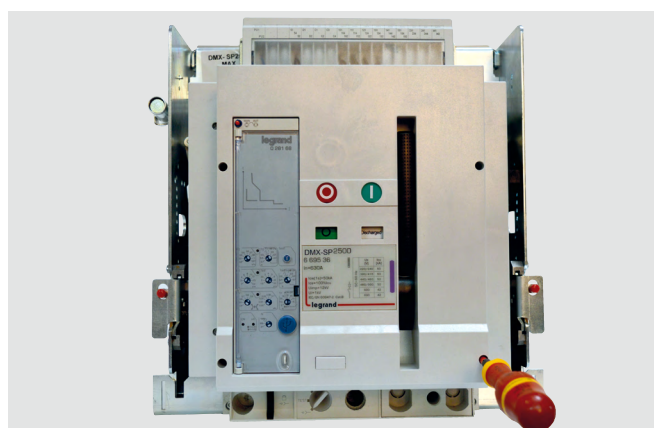

i Two positions are possible: on the left side and on the right side of the frame. Two locks can be installed simultaneously for multiple lockouts.

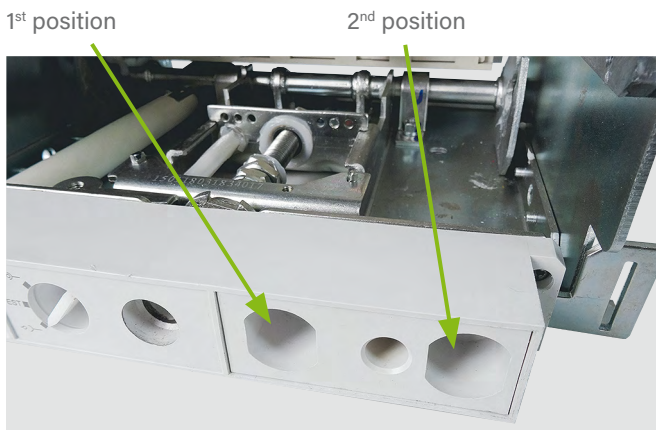

- **Example of installation on the left side of the frame**
Remove the 2 screws holding the plastic frame with a Phillips head n°2 tool.

Remove the frame from the front.

- **Top view**

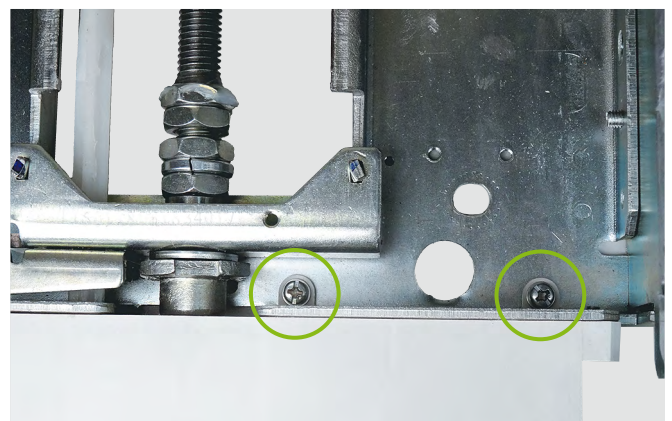

Remove the pre-cut cover with a suitable tool. Insert the barrel into the plastic frame and position the cam correctly at the back.

Fix the accessory with the nut supplied using a 16 mm flat key (tightening torque 4 Nm). Then position the key horizontally

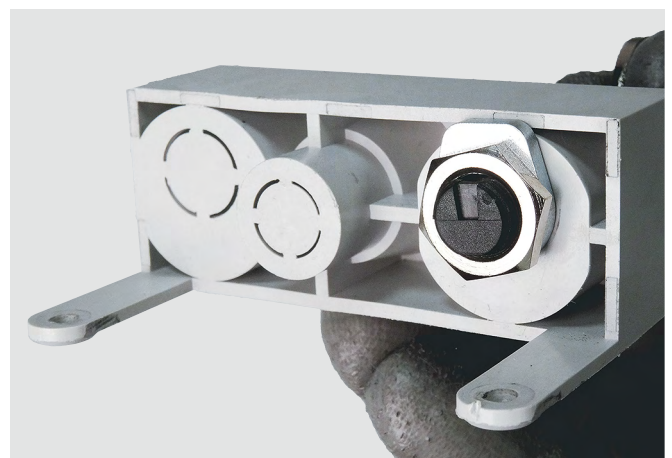

Reinsert the accessory into the base then fix it with the 2 fixing screws using a Phillips screwdriver n°2 (tightening torque 3 Nm).

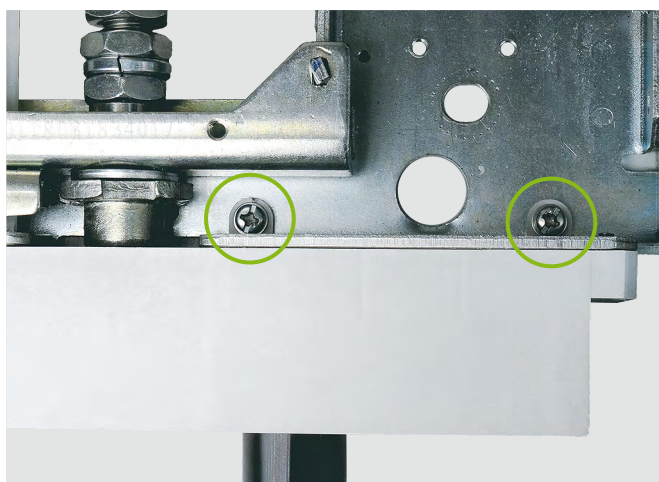

Put the DMX-SP back in its base and perform an operating test:

« Inserted » position:

1. I cannot remove the key (horizontal position).
2. I can insert the drawn-out handle.

« Test » position:

1. I cannot remove the key (horizontal position).
2. I can insert the drawn-out handle.

« Drawn-out » position:

1. I can remove the key (vertical position).
2. I cannot insert the drawn-out handle if the key is removed or is in the vertical position.

3 - Door locking (Cat.No 0 281 84)



Two parts (marked I and L on the installation instructions) are not shown on the picture because they are only used for DMX-SP mounting.

This door locking prevents the faceplate from opening/closing when the DMX-SP is in the «inserted» position. The faceplate can be opened/closed in the «test» or «drawn-out» position only.

The door locking can be installed on the left or right side of the base, respectively for a faceplate with right or left hinges. The catalogue number includes all the necessary accessories for mounting on the DMX-SP as well as on the faceplate.

MOUNTING

 Before any intervention, check that the DMX-SP is in the «OFF» position (contacts open) and the discharged spring.

- Example of a door locking on the left of the base

Use springs adapted to the mounting:

Left side mounting

Right side mounting



Position the spring on the metal lever



Insert the end of the lever into the slot of the DMX-SP and position the accessory correctly on the axis.



Insert the retaining clip then the cam with its screw (Phillips head n°2, tightening torque 3 Nm).



For the installation of the bracket on the faceplate, please see the installation instructions:

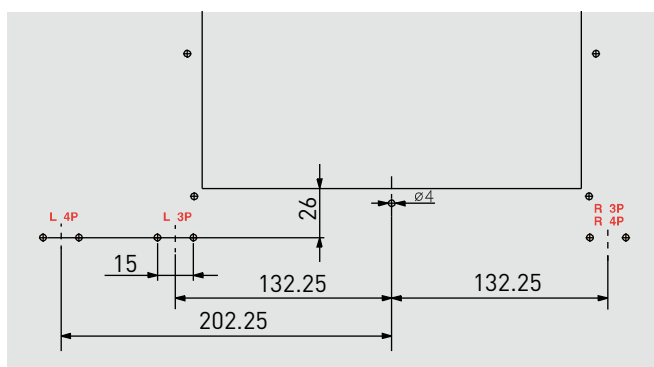

DMX-SP 2500 MECHANICAL ACCESSORIES

Example of bracket installation (on the left) on a DMX-SP faceplate.

Front view

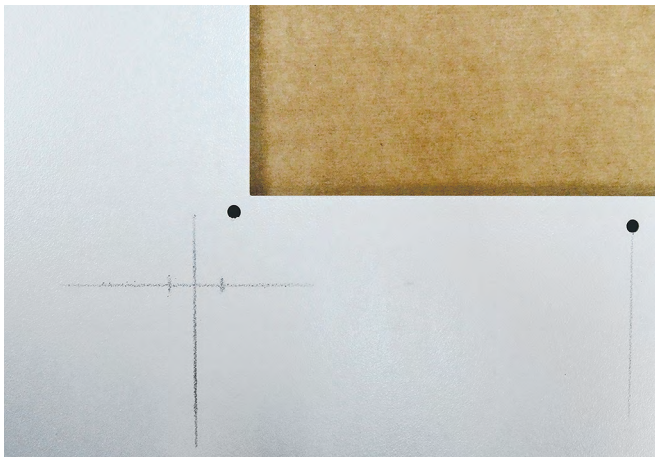

Rear view



Ø of the 2 fixing holes of the bracket : 4,5 mm

Head and tightening torque of the 2 fixing screws:

Phillips head n°2 - 3 Nm

- **Position configuration**

Inserted → impossible to open or close the faceplate

Test and drawn-out → opening and closing of the faceplate possible

4 - Mechanical counter (Cat.No 0 281 88)



The mechanical counter allows to display on the front panel of the DMX-SP the number of «closing/opening/recharged spring» cycles performed by the product.

This counter can be installed on all circuit breakers and trip-free switches of the DMX-SP 2500 range.

It is delivered with the display « 99990 ».

Its manual reset is impossible.

MOUNTING



Before any intervention, check that the DMX-SP is in the «OFF» position (contacts open), drawn-out position (if necessary) and the discharged spring.

Remove the 4 screws (Phillips head n°1) and the front panel.

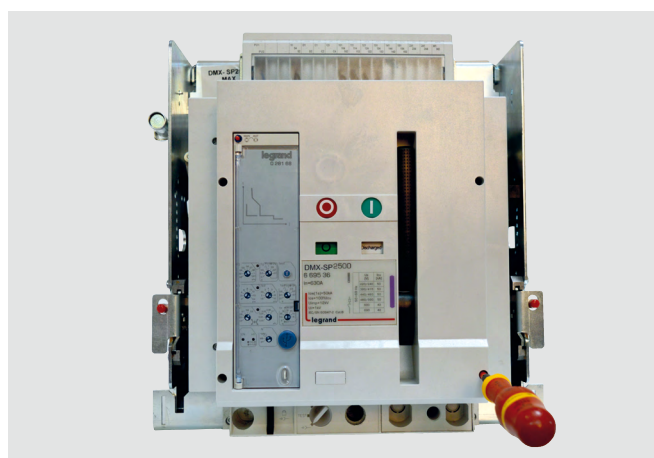
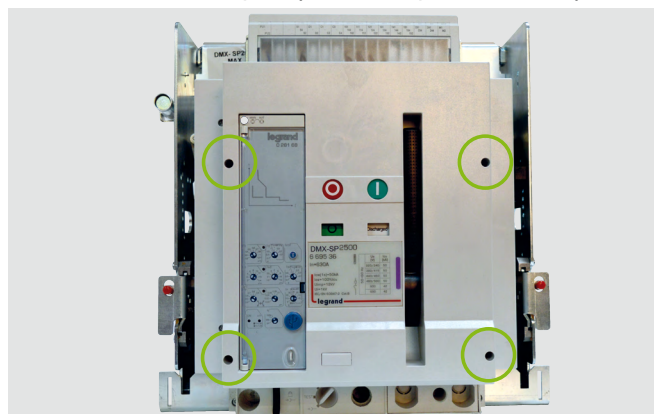

DMX-SP 2500 MECHANICAL ACCESSORIES

Position the counter correctly by engaging the pin in the hole, the metal tab on the axis and the plastic cam on the mechanism.
Pin in the hole:

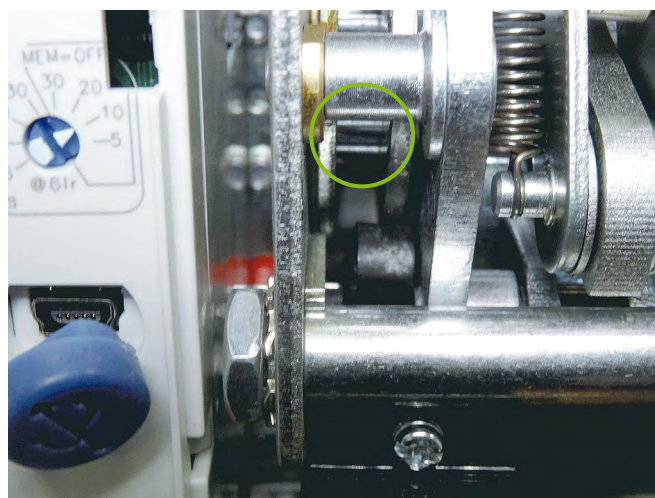
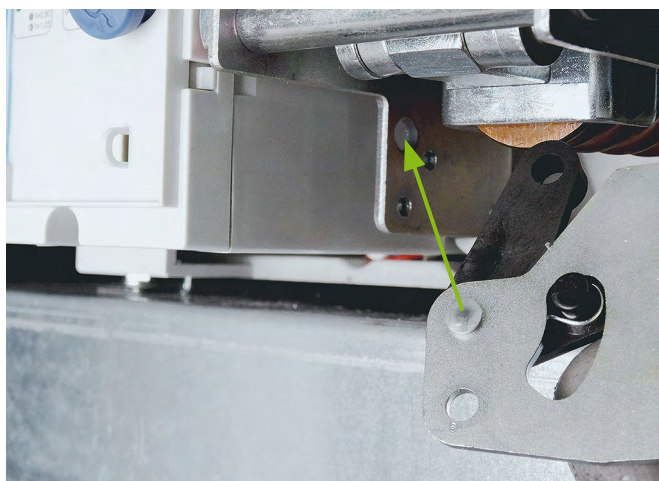

Then fix the counter with the supplied screw (Phillips head n°2, tightening torque 3 Nm).

Mounting hole on the DMX-SP:

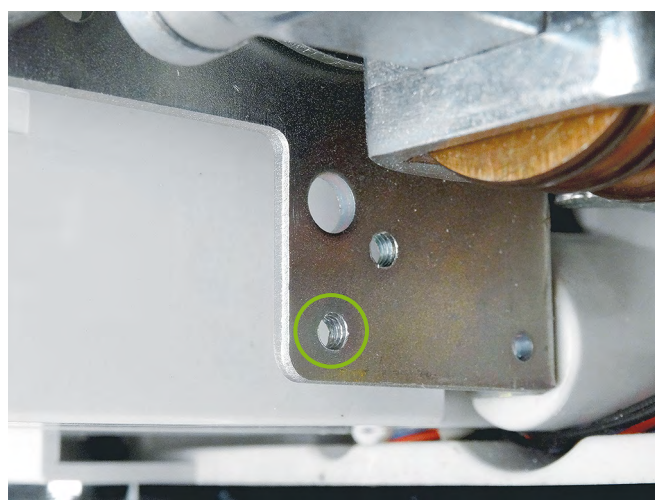
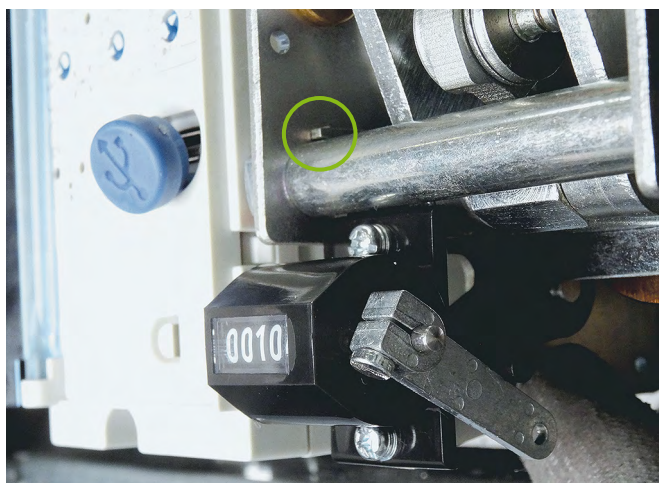

Fixing screws

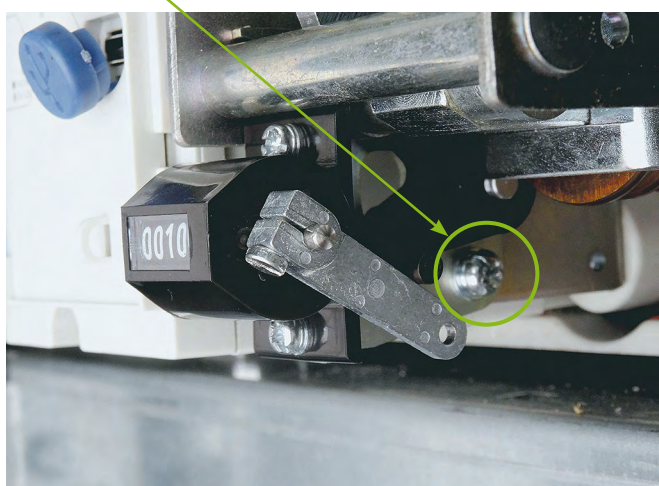

Remove the plastic cover at the back of the front panel with a flat screwdriver.

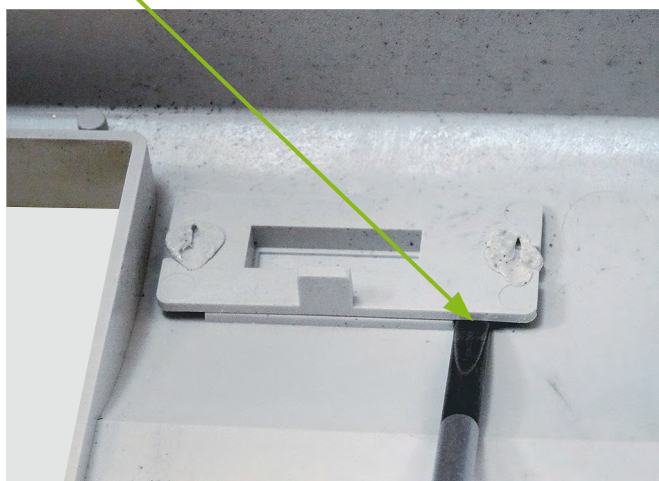

Put back in place the front panel with the 4 screws (Phillips head n°1, tightening torque 1 Nm), then the screw caps.

Re-insert the DMX-SP if necessary. Carry out 10 complete opening/closing cycles to check that the counter is correctly working.



The number of units changes as soon as the spring is fully charged. The counter is delivered with the number « 99990 » displayed. At the 10th complete cycle, it will change to « 00000 ».

5 - Inserted/test/drawn-out lock button (Cat.No 6 696 08)



This accessory allows to ensure the correct position of a DMX-SP 2500 draw-out version. It also avoids potential damages of the components when one is at the end of the inserting or drawing-out stroke.

MOUNTING



Before any intervention, check that the DMX-SP is in the «OFF» position (contacts open), drawn-out position (if necessary) and the discharged spring.

Remove the 4 screws (Phillips head n°1) and the front panel.

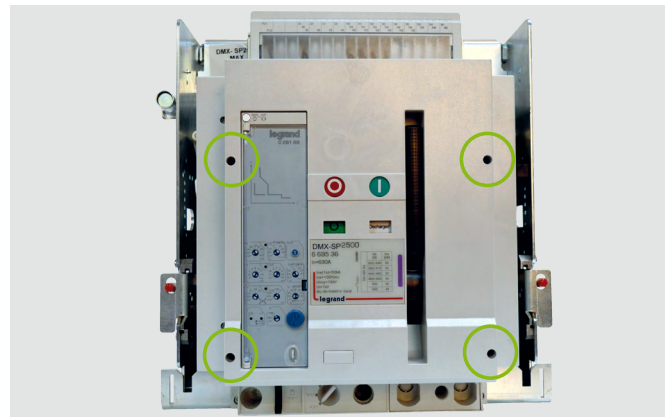

Remove the 2 screws holding the plastic frame with a Phillips head n°2 screwdriver.

Remove the frame from the front.

- Top view

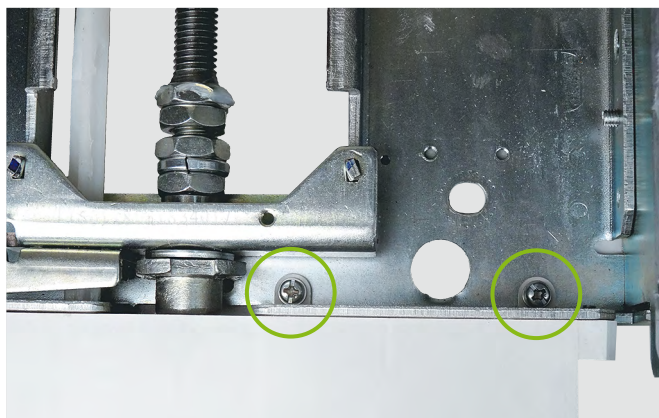

Remove the pre-cut cover with a suitable tool and deburr the contours of the hole with an electrician's knife.



Put the mechanism in place by checking its correct position then insert the 2 fixing screws supplied. Tighten these 2 screws in the base (Phillips head n°2, tightening torque 3 Nm).

Control points for correct positioning in **blue**.

Position of the mechanism's fixing screws in **red**.

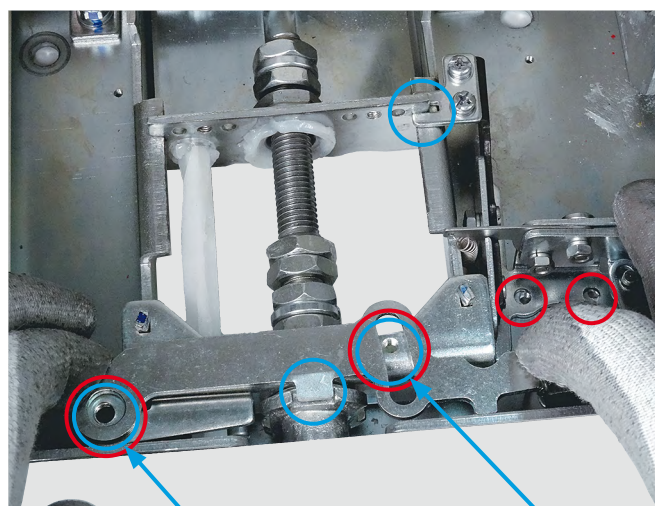

Large washer-head screw position

Small washer-head screw location

Insert the washer-head screw (the larger one) on the left side of the mechanism and tighten it (8 mm flat head, tightening torque 10 Nm).

Insert the washer-head screw (the smallest one) on the central part of the mechanism and tighten it (6.5 mm flat head, tightening torque 3 Nm).

DMX-SP 2500 MECHANICAL ACCESSORIES



Make sure that the 2 washer-head screws are correctly positioned on the mechanism (see photo below).



Re-insert the plastic frame from the front by correctly engaging the button in the previously drilled hole.

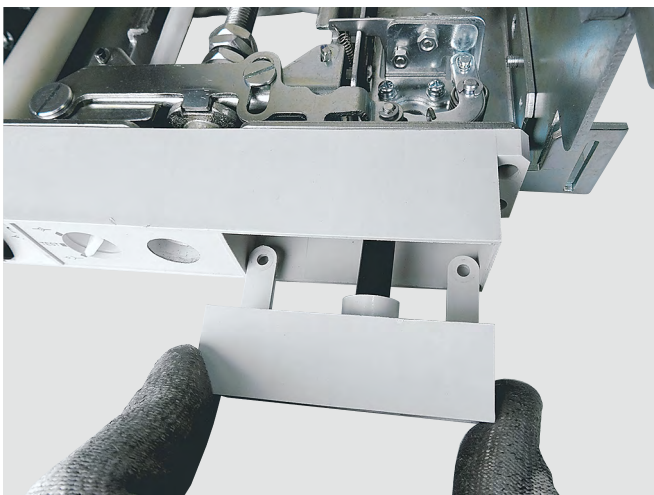

Put the 2 fixing screws back in place and tighten them (Phillips head n° 2, tightening torque 3 Nm).

For better ease of screwing, push back the button before tightening the 2 screws in order to clear the access.

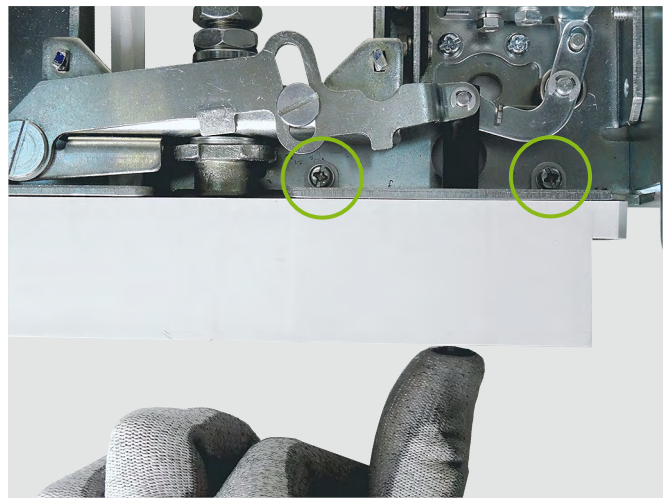

Replace the front panel using the 4 screws (Phillips head n°1, tightening torque 1 Nm), then the screw caps.

Re-insert the DMX-SP and carry out 2 complete operating tests (inserted/test/drawn-out).

OPERATION:

When the DMX-SP is in one of the three positions (inserted/test/drawn-out), the locking button is out, we can insert the inserting/drawing-out handle but not turning it.

To do this, the locking button must be pushed in. The handle can then be turned to the next position.

The same principle of operation applies to the DMX-SP for inserting and drawing-out.

6 - Rating mis-insertion device (Cat.No 0 281 89)



The rating mis-insertion device allows, when several DMX-SP are present in the same enclosure, to avoid putting the wrong DMX-SP in a base. If the size and the number of poles can be identical, the settings, the wear, the identification, the accessorization can be different.

There is one combination per rated current, i.e. 7 combinations. If there are several DMX-SP with the same rated current, several other combinations are possible. However, be careful not to put an identical one in place at another amperage.

Here is an overview of the combinations according to the rated current:

In		
630 A		
800 A		
1000 A		
1250 A		
1600 A		
2000 A		
2500 A		

DMX-SP 2500 MECHANICAL ACCESSORIES

MOUNTING



Before any intervention, check that the DMX-SP is in the «OFF» position (contacts open), drawn-out position (if necessary) and the discharged spring.

Example of a mounting on a DMX-SP 2500 In=1250A

Fix one of the 2 plates on the left side of the base with 2 countersunk screws (Phillips head n°1, tightening torque 3 Nm). The chamfered holes in the plate must be positioned on the outside of the DMX-SP.



Place the screw/washer in the plate (3 on the bottom in our example) and tighten → Allen head type 3 mm, tightening torque 3 Nm.

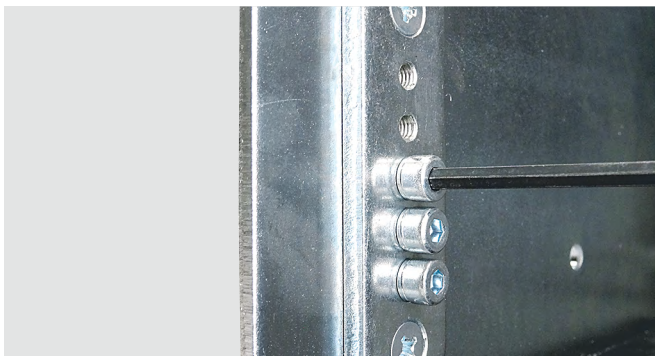

In the same way, fix the remaining plate on the left side of the DMX-SP with the 2 remaining countersunk screws (Phillips head n°1, tightening torque 3 Nm). The chamfered holes in the plate must be positioned on the outside of the DMX-SP.

Place the screws/washers in the plate (2 on the top in our example) and tighten.

→ Allen head type 3 mm, tightening torque 3 Nm.



Check the correct operation by verifying that the DMX-SP can be re-inserted without any constraints.

7 - Base for Draw-out version

The empty bases are delivered without accessories and without the auxiliary terminal block support

Example of the base Cat.No 6 696 10:



Cat.Nos	Type
6 696 10	3P
6 696 11	4P

8 - Mechanical interlock (Cat.No 0 281 90)

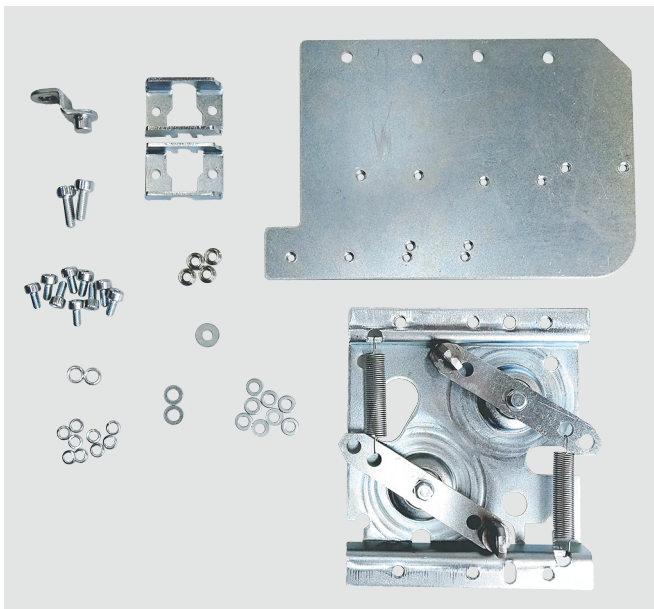

Remove the 4 screws (Phillips head n°1) and the front panel.

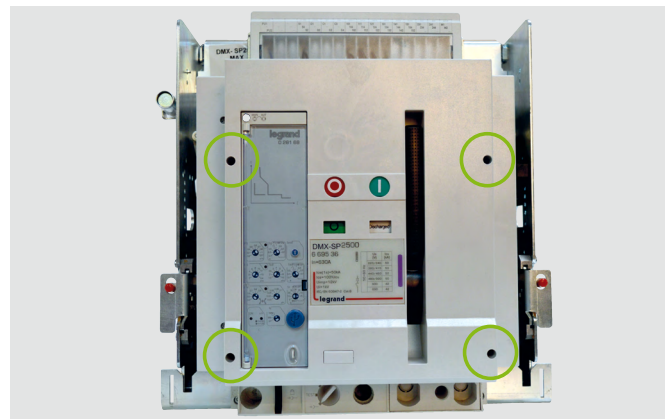

The mechanical interlock of the devices is carried out by using cables and allows to obtain a 2-device supply inverter, in vertical or horizontal configuration. It is mounted on the right side of the devices or bases.

Only Legrand interlocking cables, dedicated to DMX-SP 2500 (see page 80) must be mounted on the mechanical interlocks.

MOUNTING FOR A DRAW-OUT VERSION



Before any intervention, check that the DMX-SP is in the «OFF» position (contacts open), drawn-out position (if necessary) and the discharged spring.

Remove one part (Draw-out version) or 2 parts (fixed version) of the right side of the front panel using pliers.

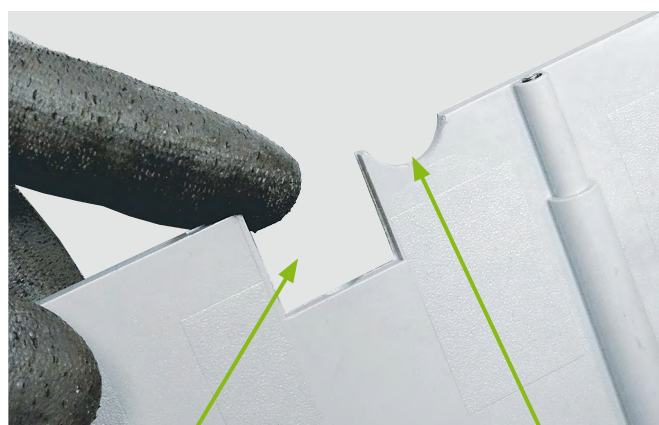

Part to remove in both versions

Part to remove for the fixed version

Install the metal bracket using the screw and washers supplied: 3 mm Allen head type, tightening torque 2 Nm.



Fix the plate with the 2 levers on the right side of the base using the 4 screws and washers supplied: 3 mm Allen head type, tightening torque 2 Nm.

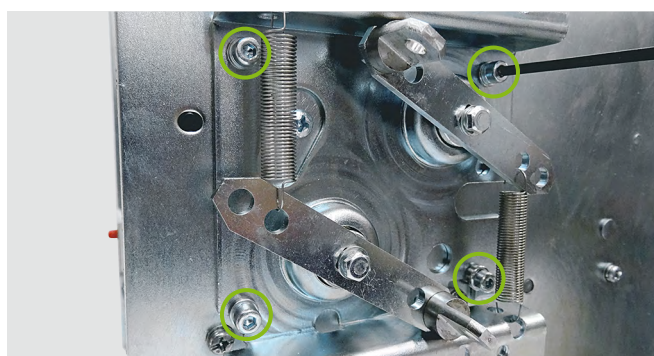

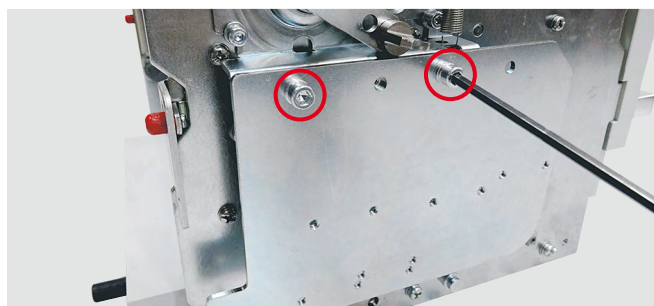

Fix the metal support on the plate with the 2 levers using the 2 screws and washers supplied: 4 mm Allen head type, tightening torque 3 Nm.



DMX-SP 2500 MECHANICAL ACCESSORIES

Fix the interlocking cables in the direction described in the installation instructions, then fix the locking flanges using the 4 screws and washers supplied: 3 mm Allen head type, tightening torque 2 Nm.

 For the choice of cables, refer to paragraph 9.

 Please respect the mounting direction of the cable flanges. Ensure that the thread length poking out from the nuts is between 0 mm and 1 mm.

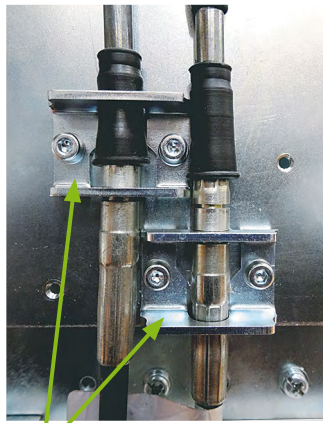

Locking flanges

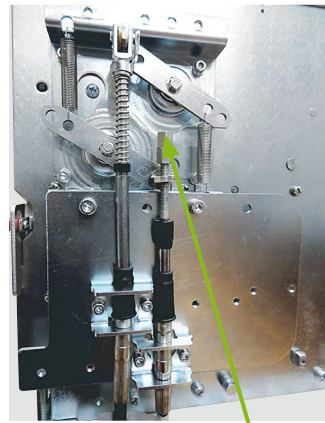

Gap between 0 mm and 1 mm

Perform the same operations described above on the 2nd product.

Re-insert the 2 DMX-SP back into their base and charge the 2 springs.

Close 1 of the 2 products.

Adjust the distance between the lever and the 1st nut on the closed DMX-SP. It must be between 3 mm and 4 mm. Also check that the 2nd cable is not flanged.

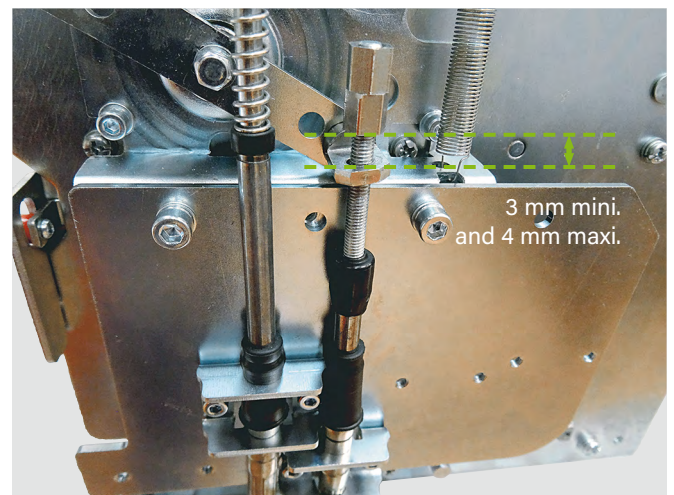

Then tighten the locknut with a 10 mm connector (tightening torque 3 Nm).

Open this DMX-SP and recharge its spring.

Close the 2nd product (not set) and make the same adjustment of the distance of the nut (between 3 mm and 4 mm). Check that the other cable is not flanged.

Then tighten the locknut using a 10 mm connector (tightening torque 3 Nm).

Check that each DMX-SP are correctly operating as well as the truth table.

i In case of malfunctioning, repeat the adjustment steps after checking that the cables are not damaged, that their length is appropriate for the configuration and that the minimum bending radius of 100 mm is respected.

Truth table :

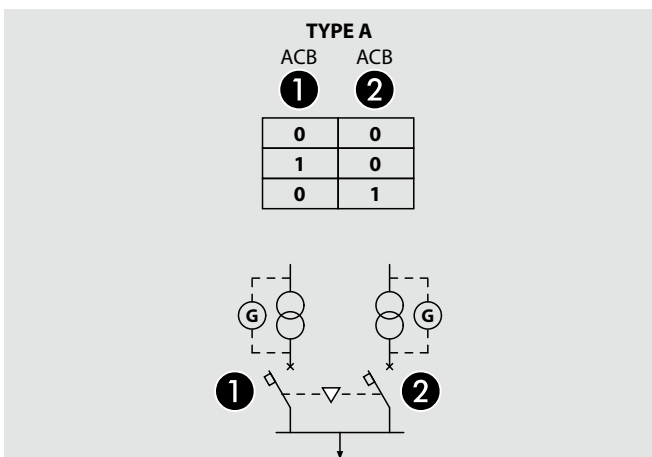

9 - Interlocking cables



The interlocking cables allow 2 DMX-SP to be mechanically connected via the mechanical interlock (see above).

The length must be chosen according to the position of the DMX-SP in the enclosure. It is important to respect the minimum bending radius of 100 mm, and to make sure that it is fixed to the enclosure structure after the mechanical system setup.

For installation, see previous pages.



For more details on cable management and wiring diagrams, please refer to the installation instructions of the mechanical interlock.

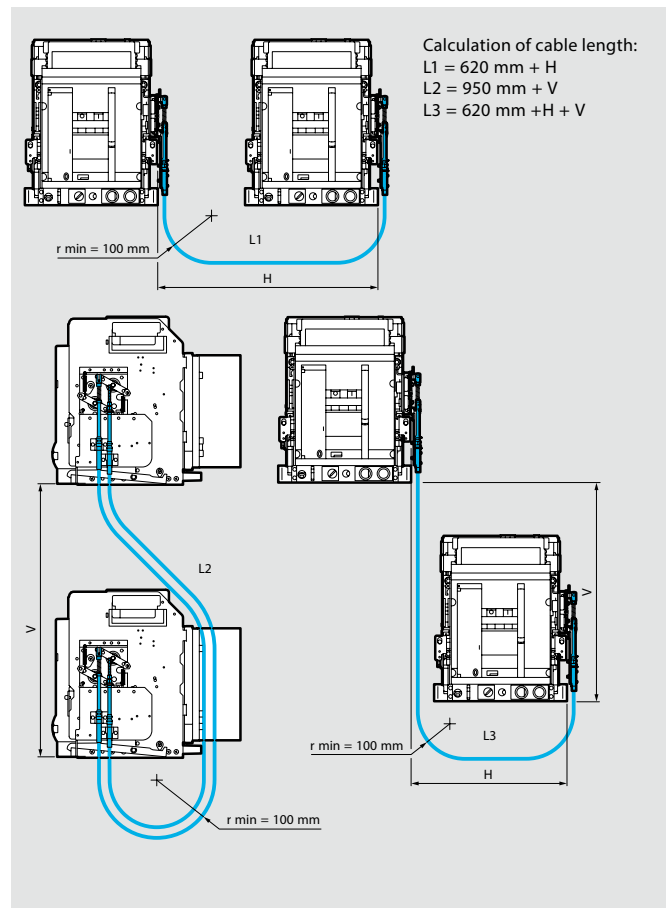

CABLE SELECTION

Cat.Nos	Length
0 289 17	1000 mm
0 289 18	1500 mm
0 289 20	2600 mm
0 289 21	3000 mm
0 289 22	3600 mm
0 289 23	4000 mm
0 289 24	4600 mm
0 289 25	5600 mm

10 - Insulation shields

Cat.Nos	Type
6 696 00	Fixed version 3P
6 696 01	Fixed version 4P
6 696 02	Draw-out version 3P
6 696 03	Draw-out version 4P

DMX-SP 4000

MECHANICAL ACCESSORIES

1. Lifting handles (Cat.No 0 288 79).
2. Key locking in « open » position (Cat.Nos 0 4 238 80/81/82/83).
3. Padlocks in « open » position (Cat.No 0 288 21).
4. Key locking in the inserted/test/drawn-out position (Cat.Nos 4 238 80/83).
5. Rating mis-insertion device (Cat.Nos 0 288 25).
6. Mechanical counter (Cat.Nos 0 288 23).
7. Padlocks in « drawn-out » position (Cat.No 0 288 26).
8. Door locking (faceplate) (Cat.No 0 288 20).
9. Mechanical interlock (Cat.No 0 288 65) and cables (Cat.Nos 0 289 17/18/20/21/22/23/24/25).
10. Insulation shields (Cat.Nos 0 288 18/19/98/99).

1 - Lifting handles (Cat.No 0 288 79)

The handles are sold in pairs. They are used to lift the devices to extract a DMX-SP from its base or to install a fixed DMX-SP in an enclosure.

For safe use, it is necessary to ensure that both lifting plates are correctly positioned, and to use the correct lifting equipment. These plates are used exclusively for handling DMX-SP.



INSTALLATION OF THE LIFTING PLATES



NOT CORRECT



CORRECT

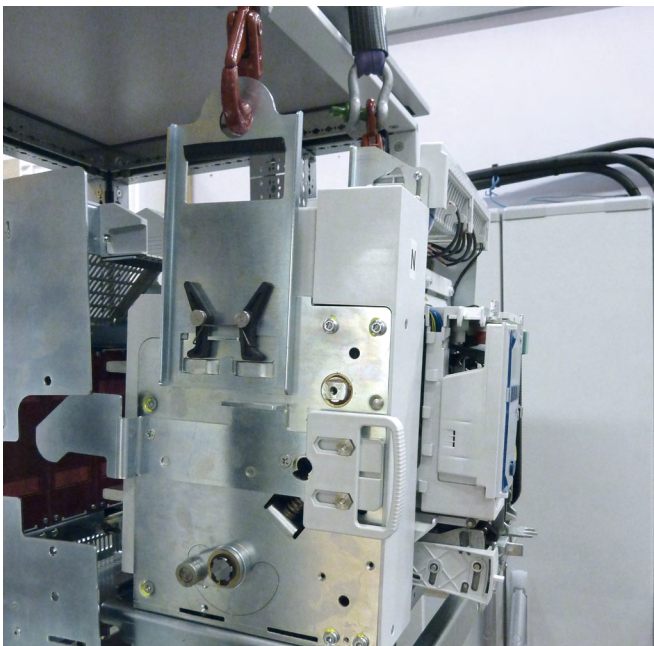

Installation of a DMX-SP draw-out version in its base.



Installation of a fixed DMX-SP.

2 - Key locking in « open » position (Cat.Nos 4 238 80/81/82/83)

The barrels in the following table must be associated with a support Cat.No 0 288 28.

Key cylinder and flat key with random marking	4 238 80
Key cylinder and flat key with EL43525 marking	4 238 81
Key cylinder and flat key with EL43363 marking	4 238 82
Key cylinder and star key with random marking	4 238 83

To lock the DMX-SP, simply press the OFF button and turn the key 1/4 turn clockwise.

To unlock the DMX-SP, simply turn the key 1/4 turn counterclockwise and the OFF button will return to its position.

In the locked position, the key is free. It is then possible to lock the unit by removing it.

In the unlocked position, the key cannot be removed.

The locking accessory has two locations. It is possible to install either a single barrel (with a flat or star key) in either of the two locations, or two identical or mixed barrels.

In the latter case, only one of the two keys is needed to lock the DMX-SP.

It is possible to order specific barrels or additional keys specifying the barrel number:

- Flat key: ABA90GEL6149
- Star key: HBA90GPS6149

However, it is necessary to order a keylock support Cat.No 0 281 91 in order to have the different fixing accessories.

Example Cat.Nos 0 288 28 + 4 238 83

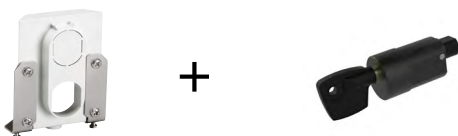

A lock in the "open" position prevents the DMX-SP from closing. It can be installed on fixed or draw-out devices, circuit breakers or trip free switches.

There are two types of locking :

- with a flat key (type RONIS);
- with a star key (type PROFALUX).

 Before any intervention, check that the DMX-SP is in the «OFF» position (contacts open), drawn-out position (if necessary) and the discharged spring.

To lock the DMX-SP, simply press the OFF button and turn the key 1/4 turn clockwise.

To unlock the DMX-SP, simply turn the key 1/4 turn counterclockwise and the OFF button will return to its position.

In the locked position, the key is free. It is then possible to lock the unit by removing it.



 Normal operation (not locked): I cannot remove the key, it is in the horizontal position.

Locked operation: I can remove the key, it is in the vertical position.

The two available slots on the key locks ensure the same locking

3 - Padlocks in « open » position (Cat.No 0 288 21)

The padlock in the «open» position prevents the DMX-SP from closing.

It can be installed on fixed or draw-out devices.

This accessory is installed in the position of the key locking in open position, so it is impossible to have a key locking in open position and a padlock in open position on the same device.

Up to three padlocks with a diameter between 6 and 8 mm can be installed. However, only one padlock can be installed to ensure locking.





Before any intervention, check that the DMX-SP is in the «OFF» position (contacts open), drawn-out position (if necessary) and the discharged spring.

Remove the 4 screws (Phillips head n°1) and the front panel.

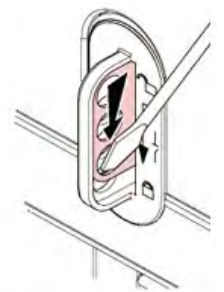

To padlock the DMX-SP, it is necessary to press and hold the OFF button and push down the metal part as shown in the illustration below.



 The Legrand offer includes a security padlock:
Cat.No 0 227 97 (6 mm diameter).



- After recharging the spring, check the correct operation of the accessory by trying to close the circuit breaker (button I).
→ impossible

4 - Key locking in the « inserted/test/ drawn-out » position (Cat.Nos 4 238 80/83)

The barrels in the following table must be associated with a support Cat.Nos 0 281 94.

Key barrel and flat key with random marking	4 238 80
Key barrel and star key with random marking	4 238 83

Example Cat.Nos 0 281 94 + 4 238 83



This accessory allows the locking in the « inserted, test and drawn-out » positions. A part supplied with the kit allows to disable the locking in the «inserted» position. It is recommended to always install this part, and therefore to disable the locking in the «inserted» position, and eventually to remove it afterwards.



Before any intervention, check that the DMX-SP is in the «OFF» position (contacts open), drawn-out position (if necessary) and the discharged spring.

Remove the 4 screws (Phillips head n°1) and the front panel.



To lock the DMX-SP Draw-out version in the «test» position and/or in the «drawn-out» position, turn the key 1/4 turn to the right after making sure that the handle is removed from the drawn-out system and that its slot is closed.

In the «locked» position, the key is free. It is then possible to lock the device by removing it.

To unlock the DMX-SP, so that it can be inserted, simply turn the key 1/4 turn to the left, thus freeing the locking system for the handle. The two available positions ensure the same lock.

There are two types of locks:

- with flat key (type RONIS)
- with star key (type PROFALUX)

It is possible to order specific barrels or additional keys by specifying the barrel number:

- flat key : ABA90GEL6149
- star key: HBA90GPS6149.

However, it is necessary to order a locking kit in order to have the different fixing accessories.

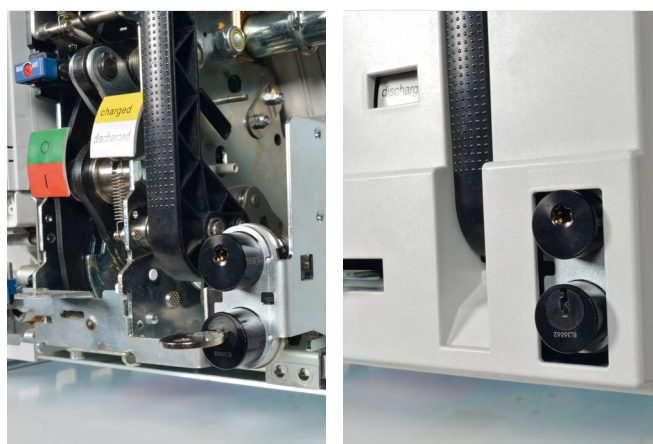

Once the mounting is done, put the DMX-SP back in its base and perform an operating test:

« Inserted » position:

1. I cannot remove the key (horizontal position).
2. I can insert the drawn-out handle.

« Test » position:

1. I cannot remove the key (horizontal position).
2. I can insert the drawn-out handle.

« Drawn-out » position:

1. I can remove the key (vertical position).
2. I cannot insert the drawn-out handle if the key is removed or is in the vertical position.







5 - Rating mis-insertion device (Cat.No. 0 288 25)

The rating mis-insertion device allows, when several DMX-SP draw-out version are installed in the same enclosure, not to change the circuit breaker in relation to its base. If the size and the number of poles can be identical, the settings, the wear, the identification, the accessories can be different.

There are nine possible coding combinations.

To install, first fix the plate supplied, under the circuit breaker, then fix one plate in the fixed base and the other on the plate, under the circuit breaker.

Then, depending on the size of the circuit breaker, insert the rating mis-insertion pins according to the attached table.

In		
3200 A		
4000 A		

6 - Mechanical counter (Cat.No. 0 288 23)



The mechanical counter allows to display on the front panel of the DMX-SP, the number of «closing/opening/recharged spring» cycles performed by the product.

This counter can be installed on all the circuit breakers of the DMX-SP range.

Its manual reset is impossible.



Before any intervention, check that the DMX-SP is in the «OFF» position (contacts open), drawn-out position (if necessary) and the discharged spring.

Remove the 4 screws (Phillips head n°1) and the front panel.



DMX-SP 4000 MECHANICAL ACCESSORIES

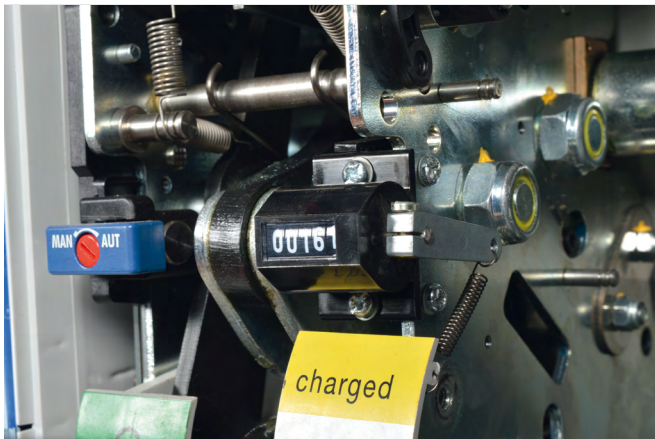
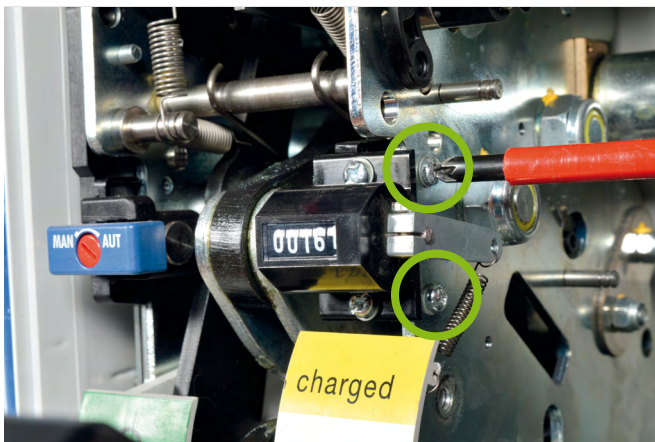

Perform 10 complete opening cycles to verify correct operation of the counter.



The number of units changes as soon as the spring is fully charged. The counter is delivered with the number « 9999 » displayed. At the 10th complete cycle, it will change to « 0000 ».

7 - Padlocks in « drawn-out » position (Cat.No 0 288 26)

This safety accessory can be equipped with two padlocks with a diameter between 5 and 8 mm. When at least one of the padlocks is installed, it stops the insulation shields from opening and, when a device is inserted, it blocks it in the «drawn-out» position by a physical stop. It is positioned at the bottom of the fixed base by simply clipping it onto the base. Once it is in the base, the DMX-SP cannot be put in «test» position.

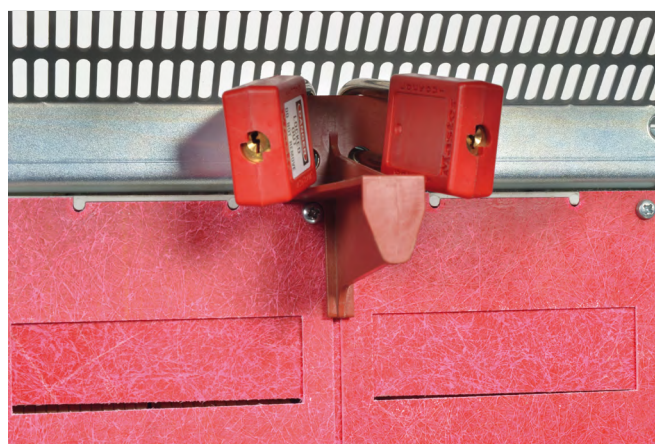

8 - Door locking (faceplate) (Cat.No 0 288 20)



This door locking prevents the hinged faceplate or door from being opened when the DMX-SP is in the «inserted» position. The faceplate can be opened in the «drawn-out» position.

Closing the faceplate remains possible in all three positions, with the DMX-SP closed or open.

The door locking can be installed on the left or right side, respectively for a faceplate with right or left hinges. The catalogue number includes all the necessary accessories for mounting the fixed part on the DMX-SP, and the removable part on the door or faceplate.

9 - Mechanical interlock and cables (Cat.No 0 288 65)



The mechanical interlock allows several DMX-SP devices to be mechanically interlocked. It is used to create a supply inverter with two or three devices (type A, B, C or D - see the next pages). There is a catalogue number for the DMX-SP 4000 (0 288 65).

Only Legrand interlocking cables, dedicated for DMX-SP (see next page) must be mounted on the mechanical interlocks.

The interlocking cables allow DMX-SP to be connected mechanically via the mechanical interlocks.

They are available in 8 standard lengths.

The length must be chosen according to the position of the DMX-SP in the enclosure. It is important to respect the minimum bending radius of 65 mm, and to make sure that over its entire length, it is fixed to the enclosure structure after the mechanical adjustment of the system.

CABLE SELECTION

Cat.Nos	Length
0 289 17	1000 mm
0 289 18	1500 mm
0 289 20	2600 mm
0 289 21	3000 mm
0 289 22	3600 mm
0 289 23	4000 mm
0 289 24	4600 mm
0 289 25	5600 mm

All DMX-SP devices can be equipped with an interlocking kit that guarantees a «mechanical safety» in case of use as a transfer switch. The connections between DMX-SP are ensured by a cable system and mechanisms fixed on each device.

This system is compatible with the entire DMX-SP range (3 and 4 pole circuit breaker, in fixed or Draw-out version, 50 kA and 65 kA) with a possible combination of the products in the range.

The mechanical interlock allows to obtain transfer switches up to three devices.

DMX-SP 4000 MECHANICAL ACCESSORIES

There are four types of possible interlocking.

• **Type A**

Possibility of locking only one of the two devices. Two interlocking cables needed.

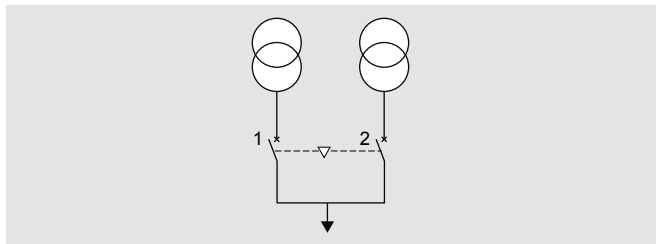

DMX-SP N°1	DMX-SP N°2
0	0
0	1
1	0

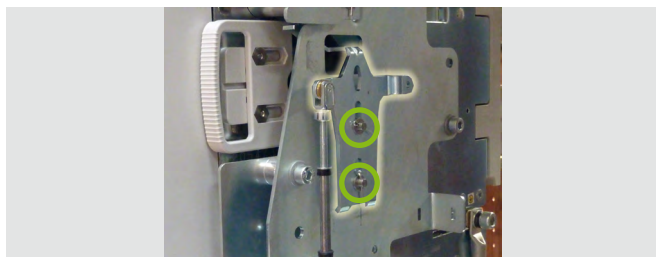

The Z parts of both devices must be installed in transverse direction, as shown in the picture.

• **Type B**

Possibility of closing only one of the three devices. Six interlocking cables needed.

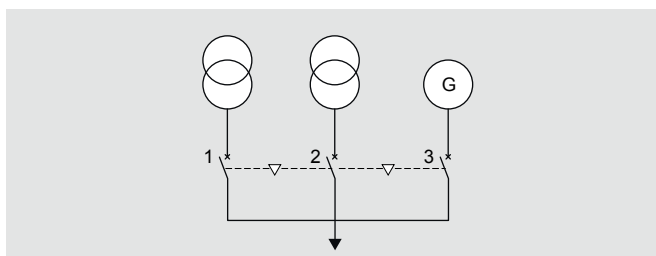

DMX-SP 4000 N°1	DMX-SP 4000 N°2	DMX-SP 4000 N°3
0	0	0
1	0	0
0	1	0
0	0	1

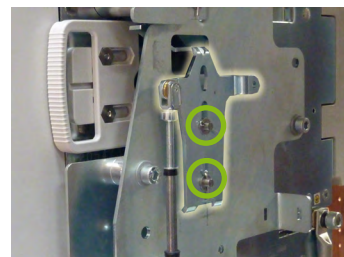

The Z parts of the three devices must be installed in transverse direction, as shown in the picture.

• **Type C**

Possibility of closing one of the three devices.

Possibility of closing two of the three devices, without the possibility of closing the third device.

Six interlocking cables needed.

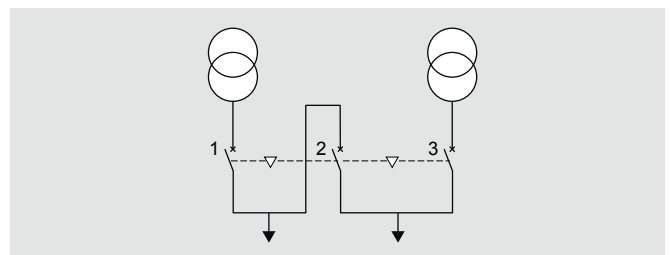

DMX-SP 4000 N°1	DMX-SP 4000 N°2	DMX-SP 4000 N°3
0	0	0
1	0	0
0	1	0
0	0	1
0	1	1
1	0	1
1	1	0



The Z parts, of the three devices, should be installed in rotation, as shown in the picture.

• Type D

Possibility of closing only one of the three devices available.

Possibility of closing two pre-determined devices (e.g. n°1 and n°2) without the possibility of closing the third (e.g. n°3)

Possibility of closing only one specific device (e.g. n°3) without the possibility of closing the other two (e.g. n°1 and n°2)

Four interlocking cables needed.

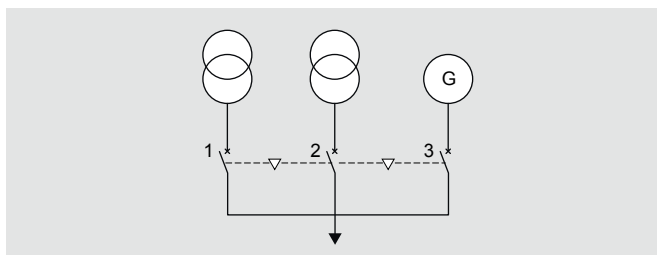

DMX-SP 4000 N°1	DMX-SP 4000 N°2	DMX-SP 4000 N°3
0	0	0
1	0	0
0	1	0
0	0	1
1	1	0

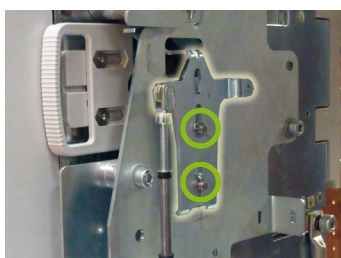

The Z parts, of the three devices, must be installed in a transverse direction, as shown in the picture.

INSTALLATION OF THE TRANSFER SWITCHES

Due to the use of flexible connections for mechanical interlocking, a transfer switch made with DMX-SP devices must be installed in the same enclosure, or in a set of adjacent enclosures.

It is possible to install up to 2 DMX-SP vertically in the same rack of an XL³S 4000 enclosure in 36 modules.

On the same horizontal level, two DMX-SP, equipped with a transfer switch, can be spaced at a maximum of 4 meters.

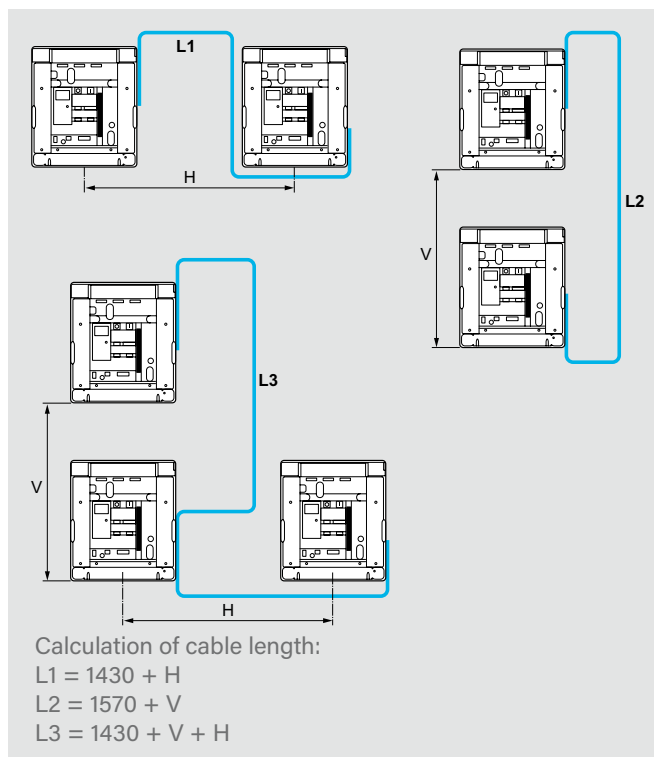

For more details on cable management and wiring diagrams, please refer to the installation instructions of the mechanical interlock.

DMX-SP 4000 MECHANICAL ACCESSORIES

A AND C TYPE TRANSFER SWITCHES WITH DMX-SP

The management automation of a two DMX-SP transfer switch can be provided by the Automatic transfer switch control units Cat.Nos 4 226 80/82/83 for the A type and Cat.No 4 226 83 for the C type, as long as both devices are equipped with at least one opening coil, one closing coil and a motor operator.

MOUNTING OF THE TRANSFER SWITCHES ON THE CIRCUIT BREAKER

Be sure to choose the right type of interlock according to the truth tables detailed in the previous pages. The number of cables will depend on the type chosen.

The weight of the circuit breakers must also be taken into account when choosing the support plate if it is not part of the Legrand offer. These weights are indicated on the installation instructions of the mechanical interlock.

To start the mounting, you must first remove the other accessories present in the circuit breaker (the RC/SC contact, the locking in the «drawn-out» position, the motor). For a fixed circuit breaker, all the parts of the interlock are mounted on it. For a draw-out version circuit breaker, some of the parts are mounted on the fixed base and some on the circuit breaker.

Below is the mounting of an interlock on a Draw-out version circuit breaker:





Before any intervention, check that the DMX-SP is in the «OFF» position (contacts open), drawn-out position (if necessary) and the discharged spring.

Remove the 4 screws (Phillips head n°1) and the front panel.

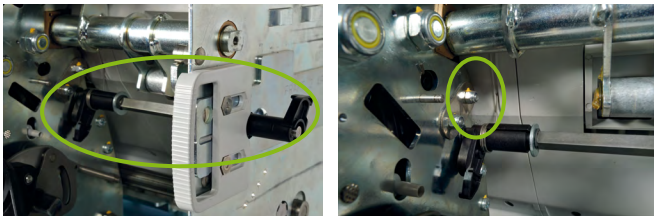

- Install the operating axis and the part that locks the closing operation of the circuit breaker



 When putting the axis in position, take care to insert the spring in its location.

- Then the part that seals the closing operation of the circuit breaker and the trip pin

Installation of the trip pin (8 Nm)



Installation of the part and its spring

- Mounting on the fixed base of the circuit breaker

The cable supports must be fixed to the plate (tighten the pins to a torque of 5 Nm to avoid any deformation). Then install the plate on the base with the appropriate wedges, fixing holes and screws.

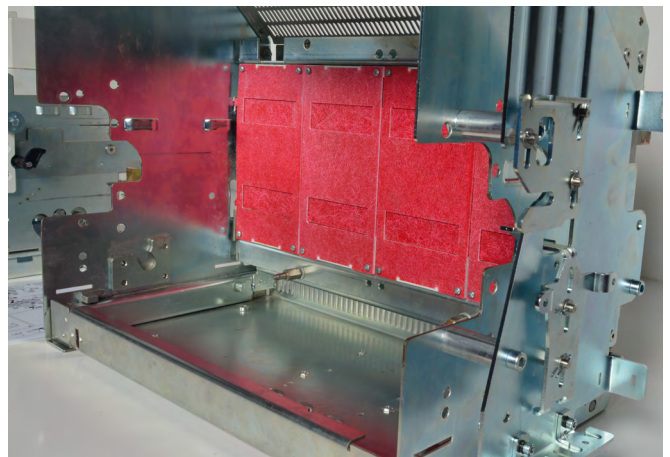
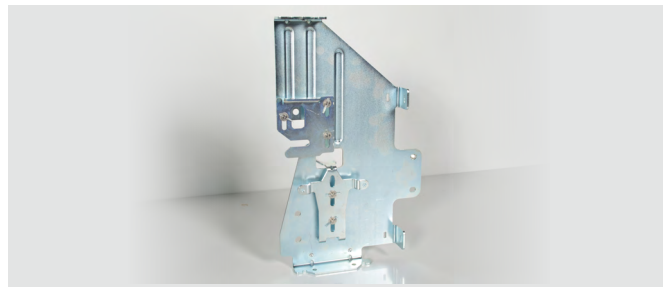

DMX-SP 4000 MECHANICAL ACCESSORIES

- Cable installation

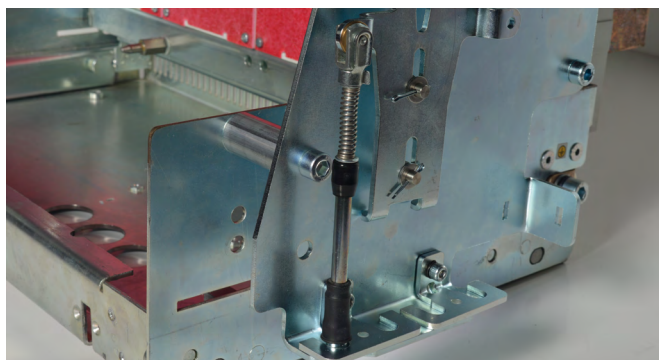

After installing the interlocks on the 2 or 3 circuit-breakers, an adjustment must be made on each of them following the instructions in the installation instructions according to the type chosen (A, B, C or D) by inserting a wedge stop. After each adjustment, perform 3 operations of opening / charging the spring / closing the circuit breaker.

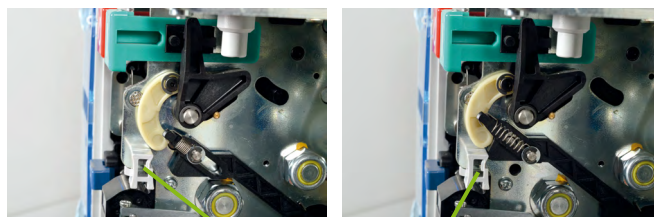

Wedge stop

10 - Insulation shields

Cat.Nos	Type
0 288 98	Fixed version 3P
0 288 99	Fixed version 4P
0 288 18	Draw-out version 3P
0 288 19	Draw-out version 4P

The mounting of the insulation shields on a fixed version circuit breaker is done by simply clipping them between the terminals of the circuit breaker.

They are high enough to isolate the upstream and downstream terminals.

POWER AND EARTH CONNECTION ACCESSORIES

The various connection accessories offer a wide range of possibilities for the entire DMX-SP range, which can easily be adapted to the desired configurations.

The screws necessary for the mounting of the different connection accessories are supplied with each product. The tightening torques to be applied are indicated in the instructions provided with the products.

The screws used for fixing the bars to the connection accessories are not supplied and are therefore the responsibility of the panel builder.

The tightening torques of the busbar fixing screws depend on their diameter and quality. It is therefore necessary to contact the manufacturer of the screws used.

Because of the wide variety of shapes and construction conditions that can affect the behavior of the device, the solution chosen must always be checked. If the distance between the poles is less than 20 mm, it is recommended to use phase insulators or insulated bars.

CATALOGUE NUMBERS TABLE FOR DMX-SP 2500:

Cat.Nos	Type	Version	Tightening torque on DMX-SP
0 288 82	Rear terminals 3P vertical connection	Fixed	25 Nm
0 288 83	Rear terminals 4P vertical connection	Fixed	25 Nm
0 288 84	Rear terminals 3P flat connection	Fixed	36 Nm
0 288 85	Rear terminals 4P flat connection	Fixed	36 Nm
0 288 86	Spreaders 3P flat connection	Fixed	36 Nm*
0 288 87	Spreaders 4P flat connection	Fixed	36 Nm*
0 288 88	Spreaders 3P vertical connection	Fixed	36 Nm*
0 288 89	Spreaders 3P vertical connection	Fixed	36 Nm*
0 288 90	Spreaders 3P horizontal connection	Fixed	36 Nm*
0 288 91	Spreaders 4P horizontal connection	Fixed	36 Nm*
0 288 96	Rear terminals 3P	Draw-out	25 Nm
0 288 97	Rear terminals 4P	Draw-out	25 Nm
6 696 18	Rear terminals 3P aluminium, In = 1600 A max.	Fixed/Draw-out	10 Nm
6 696 19	Rear terminals 4P aluminium, In = 1600 A max.	Fixed/Draw-out	10 Nm

*Spreaders are fixed on the rear terminals with the screws, washers and nuts provided.

CATALOGUE NUMBERS TABLE FOR DMX-SP 4000

Cat.Nos	Type	Version	Tightening torque on DMX-SP
0 288 94	Rear terminals 3P vertical & horizontal connection	Fixed and draw-out	36 Nm
0 288 95	Rear terminals 4P vertical & horizontal connection	Fixed and draw-out	36 Nm
6 696 14	Rear terminals 3P flat connection	Fixed	36 Nm
6 696 15	Rear terminals 4P flat connection	Fixed	36 Nm

DMX-SP FIXED VERSION

- Size 2500: six possible configurations of rear terminals, horizontal, vertical, flat, horizontal spreaders, vertical spreaders and flat spreaders
- Size 4000: three possible configurations of rear terminals, horizontal, vertical and flat.

The 3P and 4P insulation shields for fixed and draw-out versions are for the DMX-SP 4000 sizes.

• Horizontal connection

The fixed DMX-SP are equipped with rear terminals with horizontal connection with bars. It is possible to directly connect copper or aluminum bars.

• Flat connection

The flat connection accessories are directly fixed on the horizontal connection terminals integrated to the DMX³ fixed version.

Copper or aluminum bars are directly bolted to the flat connection ranges, e.g. vertical bar ends upstream. The flat connection kit is required for the use of DMX-SP/ SCP/XCP connection kits.

It is possible to install insulation shields between the poles. The shields are high enough to insulate both the upstream and downstream terminals equipped with the flat connection accessories.

• Vertical connection

For DMX-SP 2500 et 4000, the vertical connection kit is fixed. It is mounted on the flat connection kit.

The copper or aluminum bars are directly bolted to the vertical ranges, e.g. connections to a transfer busbar. It is possible to install insulation shields between the poles. The shields are high enough to insulate both the upstream and downstream terminals equipped with the vertical connection kits.

• Connection with flat, vertical and horizontal spreaders

Only the fixed DMX-SP 2500 can be equipped with spreaders. The new center distance is then increased from 85 mm to 116.5 mm (3P) or 106 mm (4P).

It is not possible to install insulation shields when the DMX-SP is equipped with spreaders.

The copper or aluminum bars are directly connected to the spreaders.

DMX-SP DRAW-OUT VERSION

The rear terminals and connection accessories of the DMX-SP draw-out versions allow 3 connection configurations: flat, horizontal and vertical. Insulation shields can be installed between each pole on all drawn-out devices. The shields are high enough to insulate both the upstream and downstream terminals.

• Flat connection

The draw-out DMX-SP is originally, without other accessories, equipped with flat connection terminals (see next page). It is possible to directly connect copper or aluminum bars.

• Horizontal/vertical connection

For DMX-SP 2500 and 4000 the rear terminals can be oriented horizontally or vertically.

It is possible to directly attach copper or aluminum bars to it, such as connections to a transfer busbar system.

Drawings of the connection accessories for DMX-SP 2500

- Drawings Cat.Nos 0 288 82/83

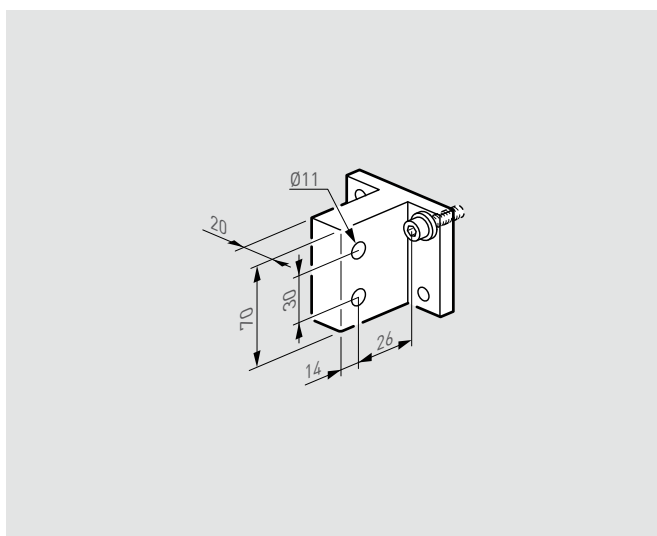

- Drawings Cat.Nos 0 288 84/85

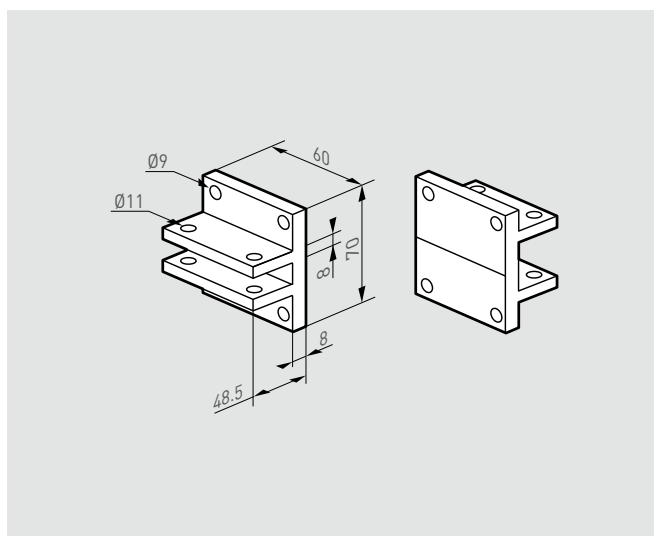

- Drawings Cat.Nos 0 288 86/87

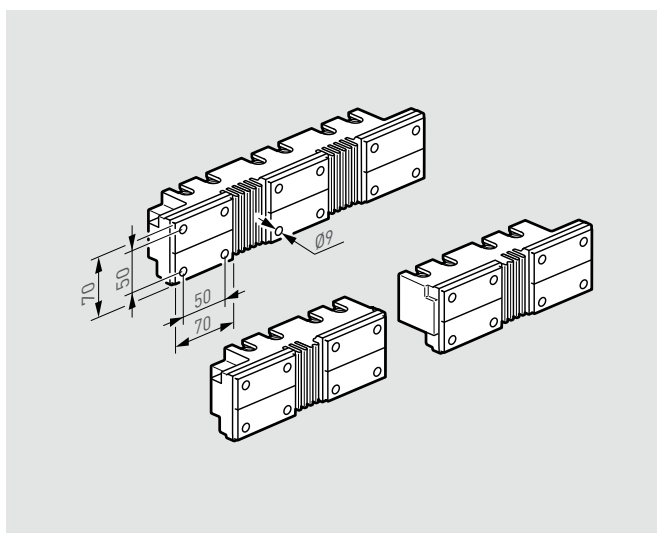

- Drawings Cat.Nos 0 288 88/89

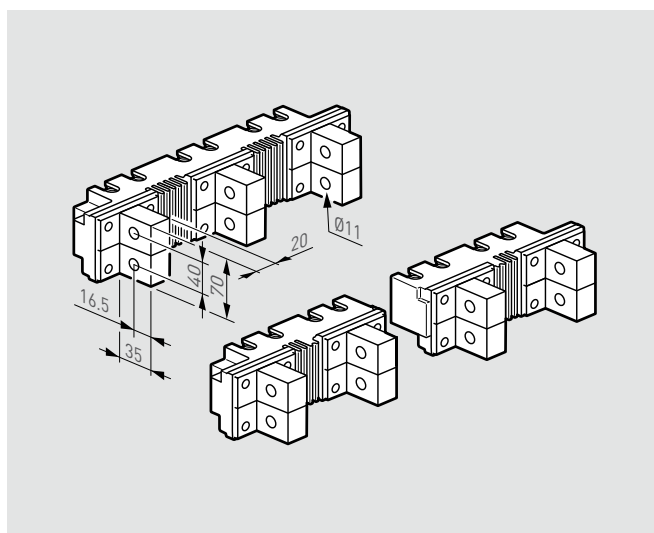

• Drawings Cat.Nos 0 288 90/91

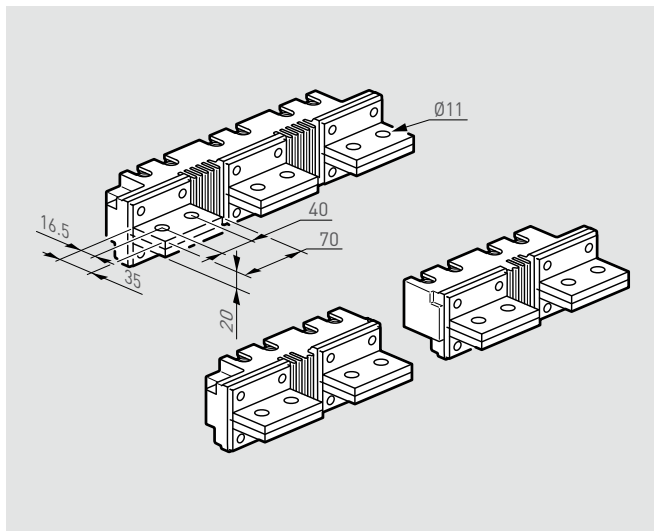

• Drawings Cat.Nos 0 288 96/97

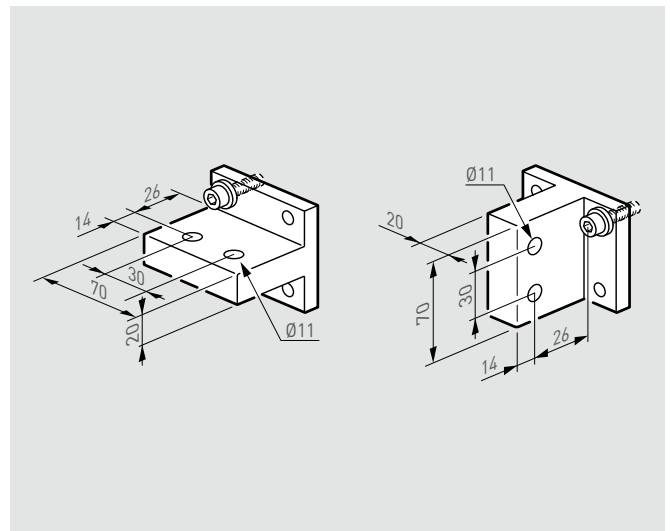

POWER AND EARTH CONNECTION ACCESSORIES

FIXED VERSION

Overall depth of a fixed DMX-SP 2500 3P-4P with rear terminals.

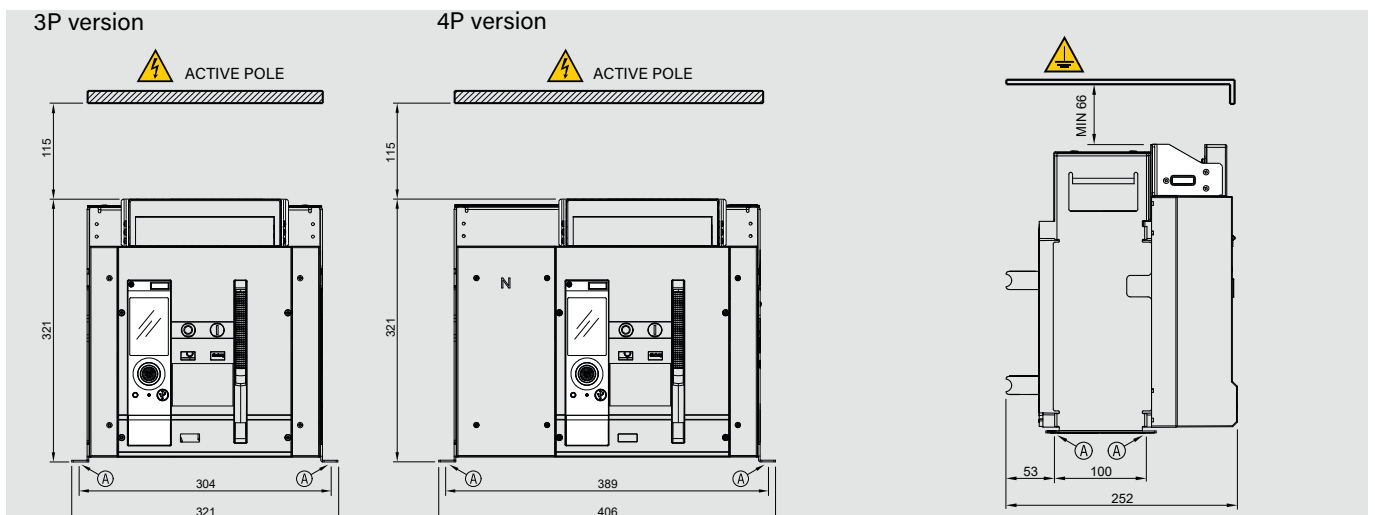

Ⓐ: Fixing points on the plate

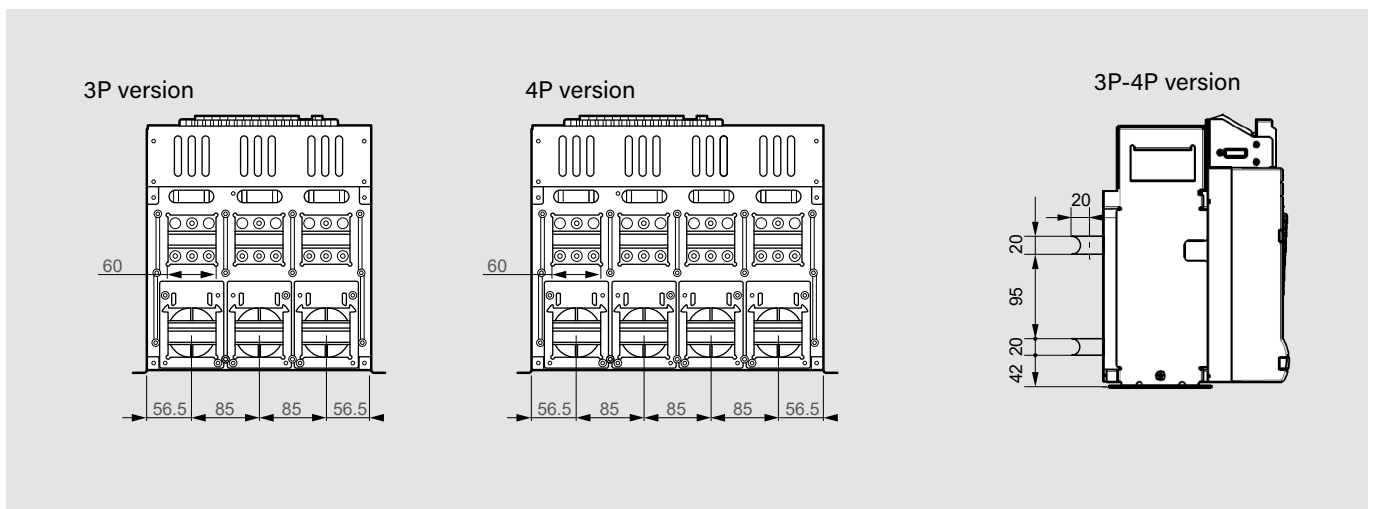

DRAW-OUT VERSION

Overall depth of a 3P-4P draw-out DMX-SP 2500 with rear terminals:

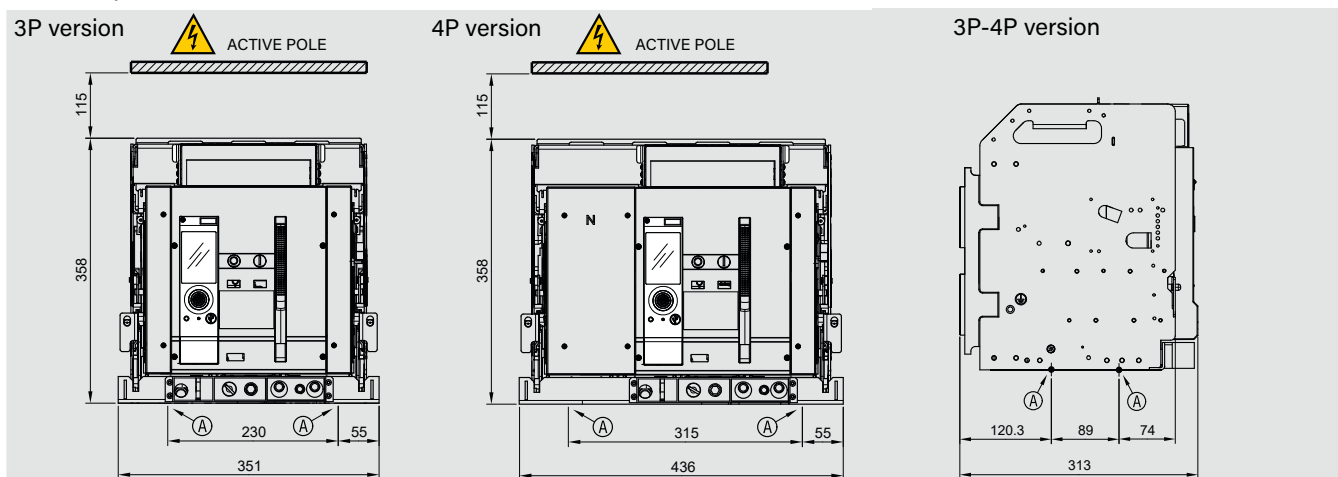

Ⓐ: Fixing points on the plate

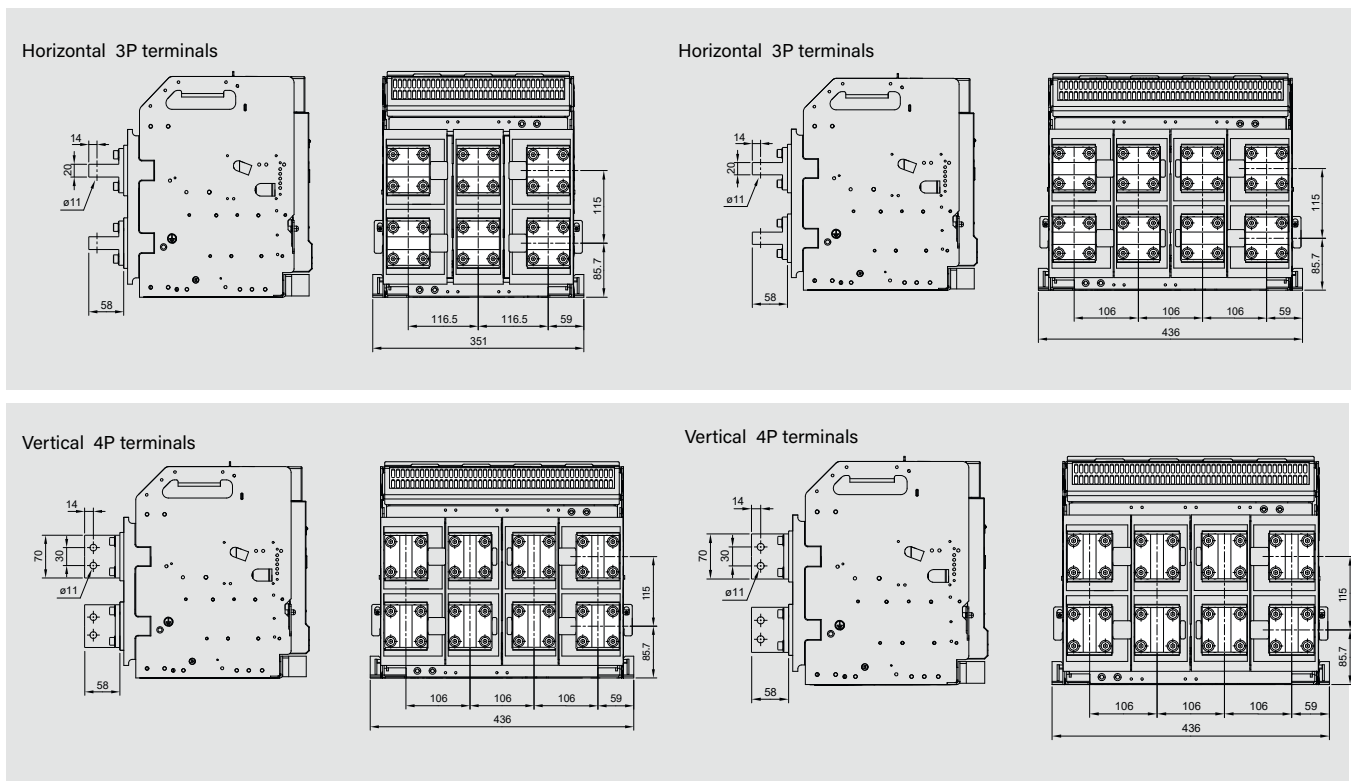

POWER AND EARTH CONNECTION ACCESSORIES

Flat terminals
3P

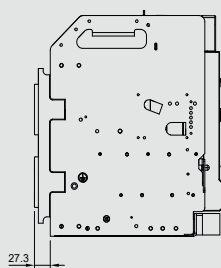

Flat terminals 4P

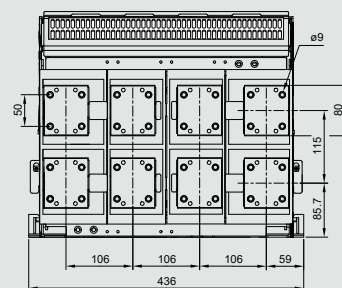
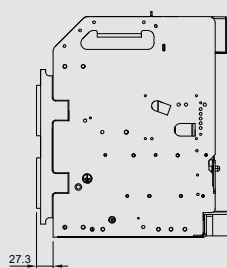
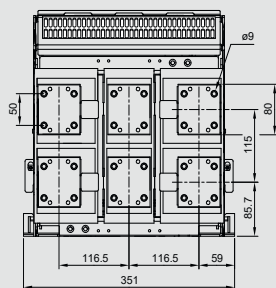

Drawings of the connection accessories for DMX-SP 4000

- Drawings Cat.Nos 0 288 94/95

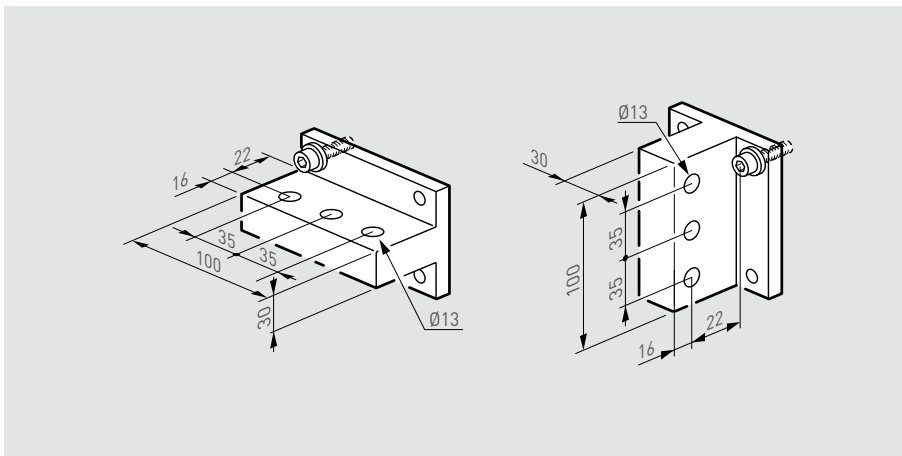

- Drawings Cat.Nos 6 696 14/15

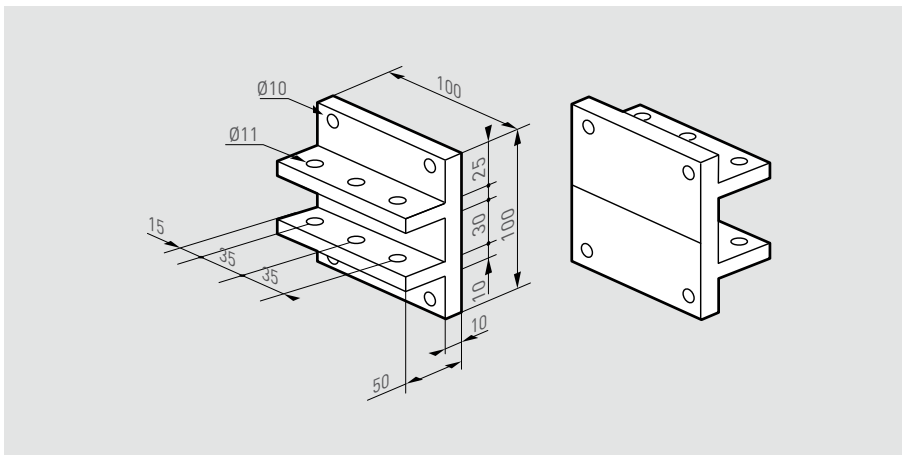

POWER AND EARTH CONNECTION ACCESSORIES

FIXED VERSION

Overall depth of a 3P-4P fixed DMX-SP 4000 with rear terminals

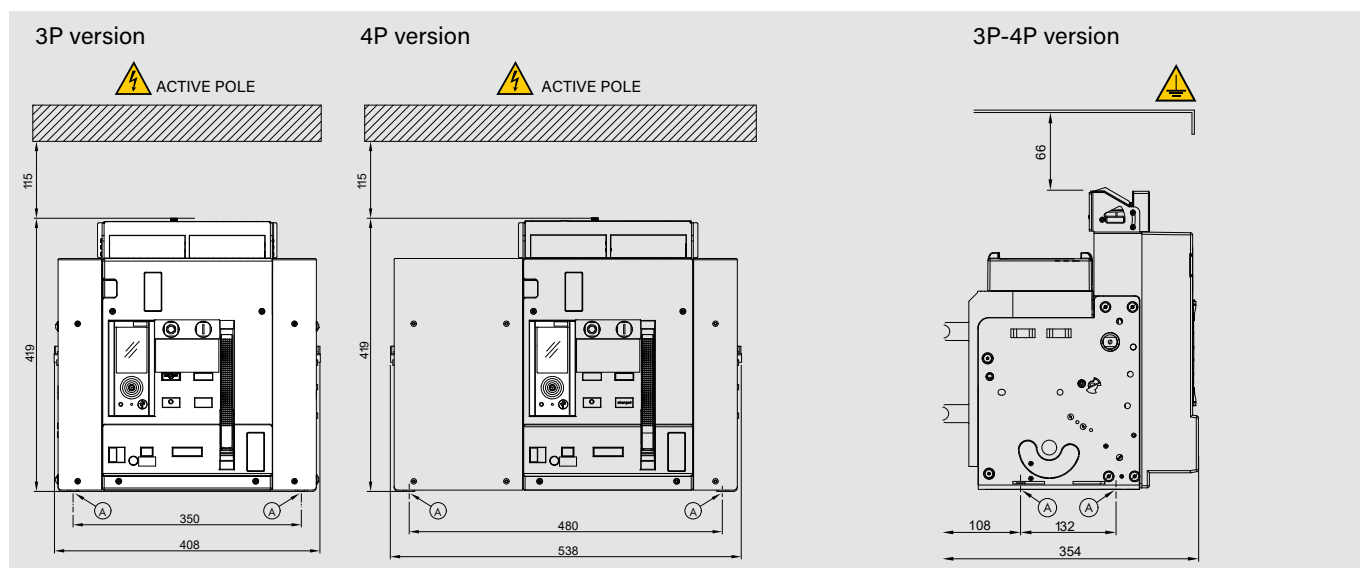

Ⓐ: Fixing points on the plate

Rear terminals for horizontal connections with busbar

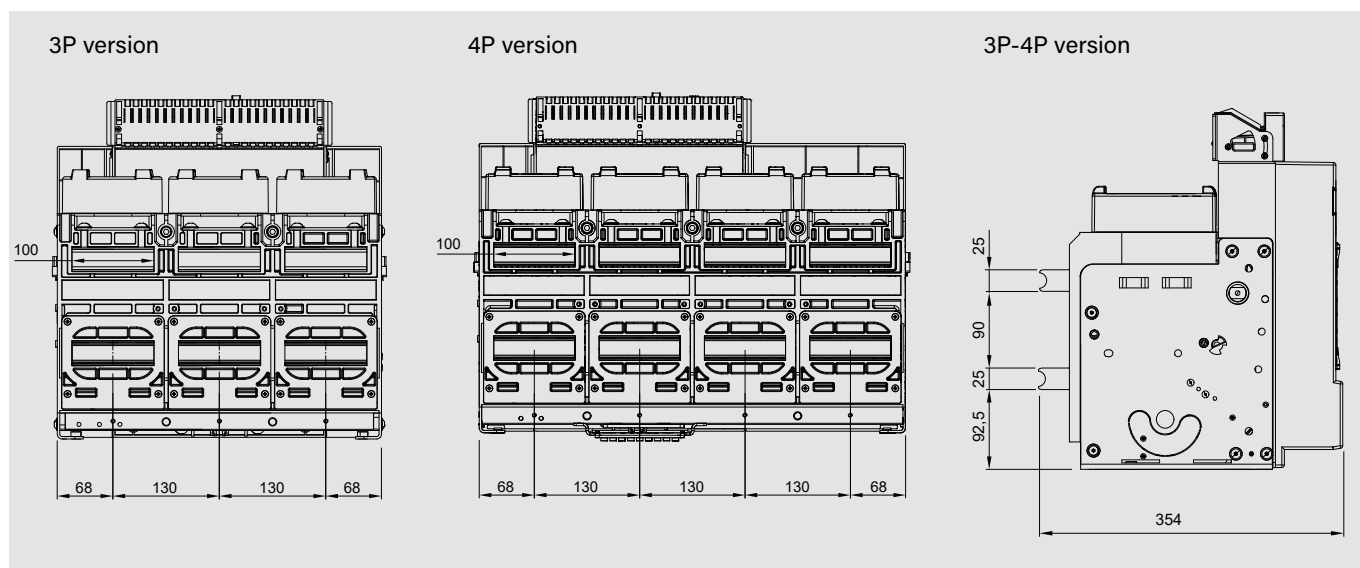

DRAW-OUT VERSION

Overall depth of a 3P-4P drawn-out DMX-SP 4000 with rear terminals

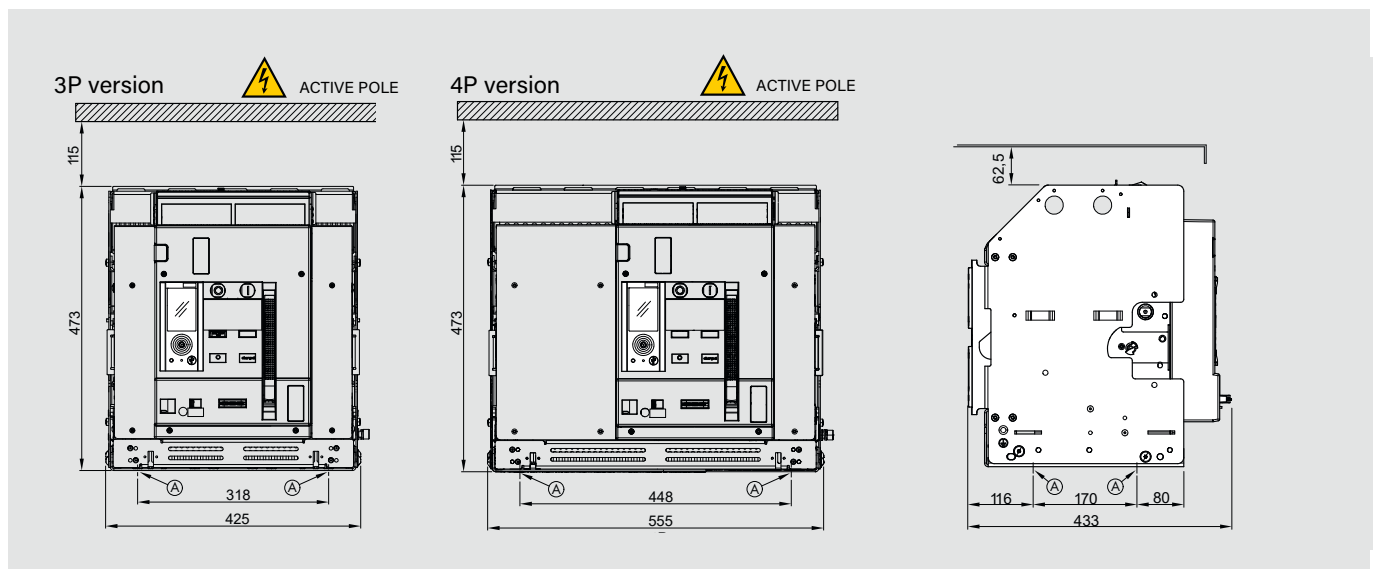

Ⓐ: Fixing points on the plate

Rear terminals for flat connections with busbar

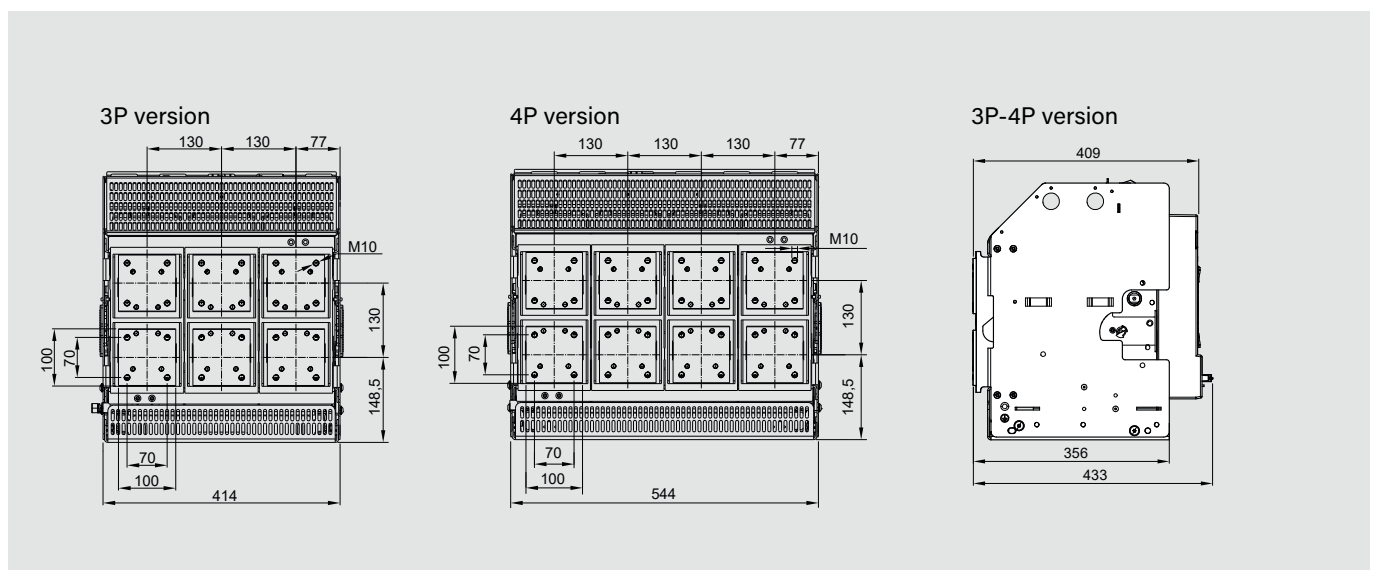

POWER AND EARTH CONNECTION ACCESSORIES

Rear terminals for horizontal connections with busbar

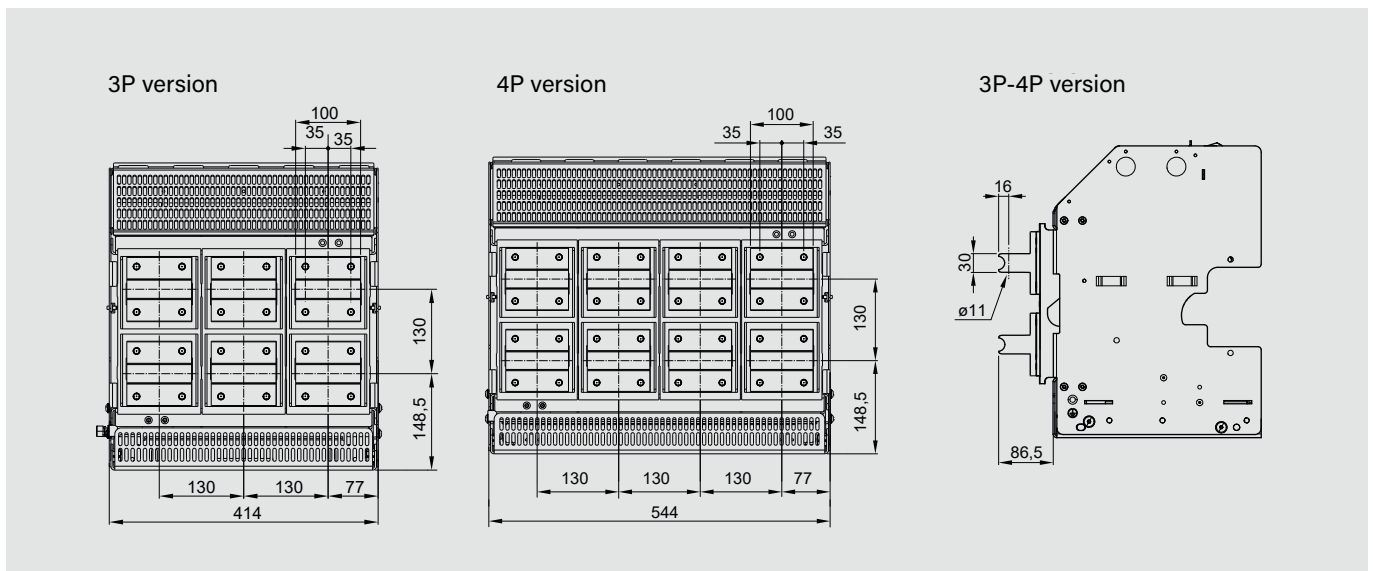

Rear terminals for vertical connections with busbar

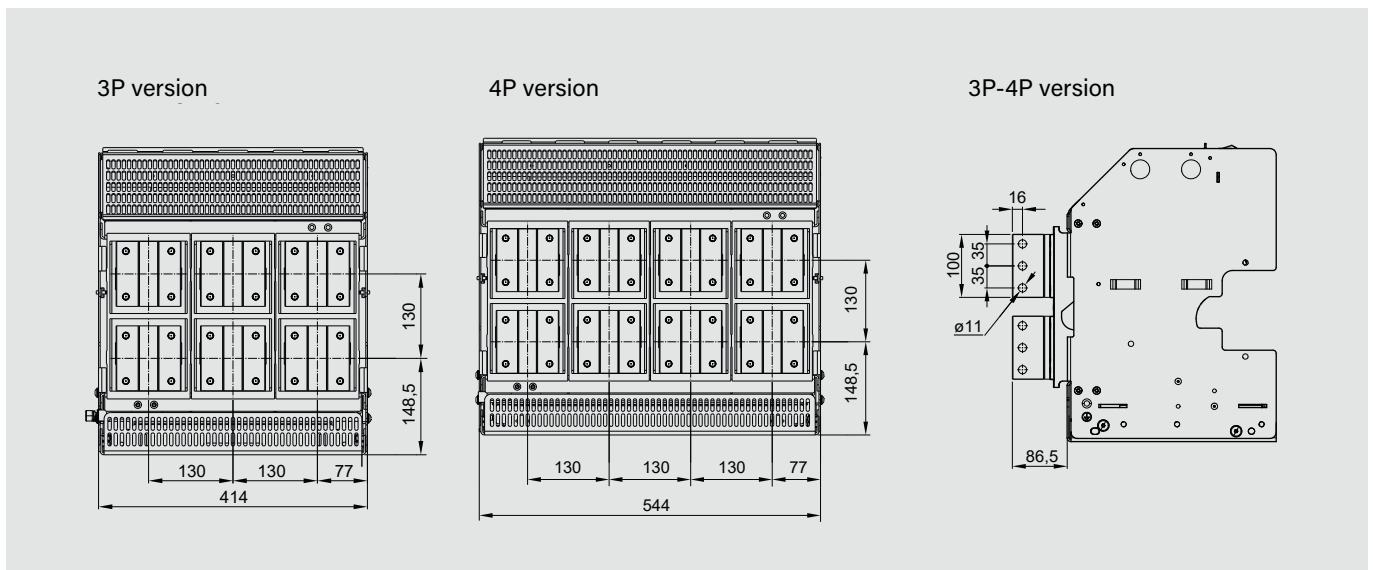

Horizontal rear outlets combined with a busbar system

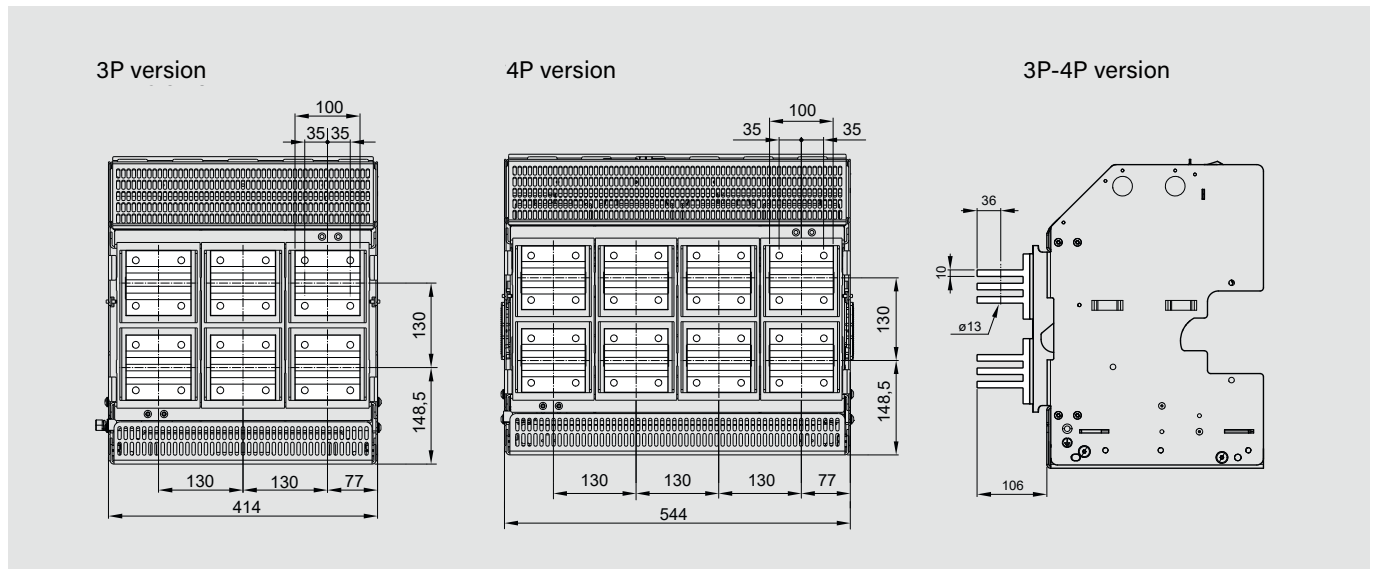

Vertical rear outlets combined with a busbar system

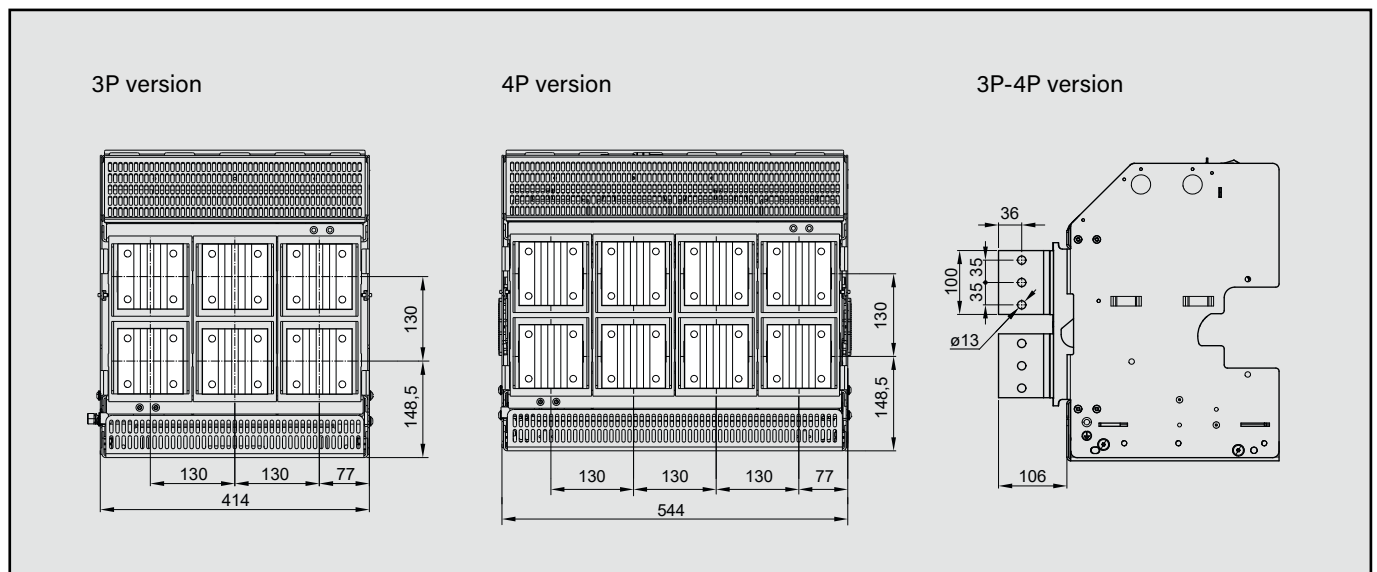

POWER AND EARTH CONNECTION ACCESSORIES

ELECTRICAL CONNECTIONS FOR DMX-SP 2500 CIRCUIT BREAKERS

- Minimum cross-section of COPPER bars per pole

Fixed version

In (A)	Vertical bars (mm)	Horizontal bars (mm)
630	2 bars 40 x 5	2 bars 40 x 5
800	2 bars 50 x 5	2 bars 30 x 10
1000	1 bar 60 x 10 / 2 bars 60 x 5	1 bar 60 x 10 / 2 bars 60 x 5
1250	1 bar 80 x 10 / 2 bars 80 x 5	1 bar 80 x 10 / 2 bars 80 x 5
1600	2 bars 50 x 10	2 bars 50 x 10
2000	3 bars 50 x 10	3 bars 50 x 10
2500	3 bars 80 x 10	4 bars 80 x 10 / 5 bars 60 x 10

Draw-out version

In (A)	Vertical bars (mm)	Horizontal bars (mm)
630	2 bars 40 x 5	2 bars 40 x 5
800	2 bars 50 x 5	2 bars 30 x 10
1000	2 bars 60 x 10	2 bars 30 x 10
1250	2 bars 80 x 10	2 bars 40 x 10
1600	2 bars 50 x 10	2 bars 50 x 10
2000	3 bars 50 x 10	3 bars 50 x 10
2500	3 bars 80 x 10	4 bars 80 x 10

- Minimum cross-section of ALUMINUM bars per pole

Fixed version

In (A)	Vertical bars (mm)	Horizontal bars (mm)
630	2 bars 50 x 8	2 bars 50 x 10
800	2 bars 50 x 10	2 bars 50 x 10
1000	2 bars 60 x 10	4 bars 30 x 10
1250	2 bars 60 x 10	4 bars 50 x 10
1600	4 bars 50 x 10	5 bars 50 x 10
2000	4 bars 60 x 10	4 bars 80 x 10
2500	4 bars 100 x 10	5 bars 100 x 10

Draw-out version

In (A)	Vertical bars (mm)	Horizontal bars (mm)
630	2 bars 50 x 8	2 bars 50 x 10
800	2 bars 50 x 10	2 bars 50 x 10
1000	2 bars 60 x 10	4 bars 30 x 10
1250	2 bars 60 x 10	4 bars 50 x 10
1600	4 bars 50 x 10	5 bars 50 x 10
2000	4 bars 60 x 10	4 bars 80 x 10
2500	4 bars 100 x 10	5 bars 100 x 10

ELECTRICAL CONNECTIONS FOR DMX-SP 4000 CIRCUIT BREAKERS

- Minimum cross-section of COPPER bars per pole

Fixed and draw-out version

In (A)	Vertical bars (mm)	Horizontal bars (mm)
3200	3 bars 100 x 10	4 bars 80 x 10
4000	4 bars 100 x 10	5 bars 100 x 10

- Minimum cross-section of ALUMINUM bars per pole

Fixed and draw-out version

In (A)	Vertical bars (mm)	Horizontal bars (mm)
3200	4 bars 150 x 10	5 bars 150 x 10
4000	5 bars 150 x 10	6 bars 150 x 10

EARTH CONNECTION:

- For DMX-SP 2500

To make the earth connection, use the hole provided and fix the cable lug (fixing kit included in the draw-out version, not included in the fixed version) with an M8 bolt.

Fixed version

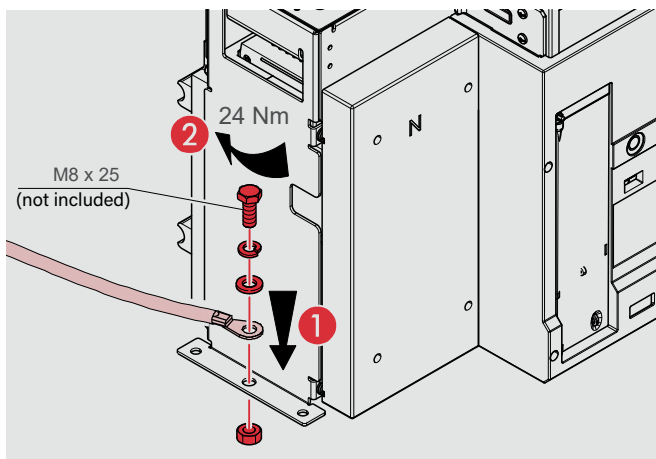

Draw-out version

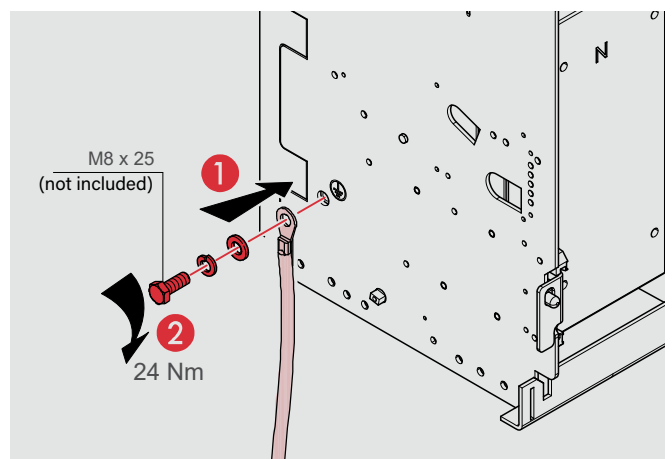

 Do not use the DMX-SP fixing points as connection points.

- For DMX-SP 4000:

To make the earth connection, use the dedicated hole and fix the cable lug (fixing kit included in the draw-out version, not included in the fixed version) with an M10 bolt.

Fixed version

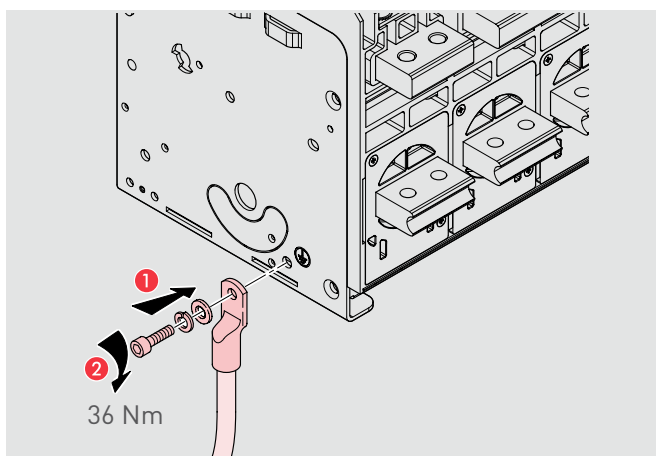

Draw-out version

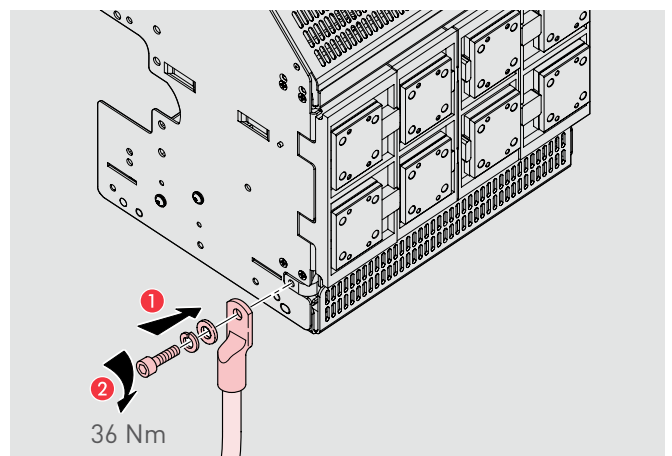

DMX-SP

CABINET INSTALLATION

XL³ S enclosure

The XL³ S 4000 cabinets are equipped with components specifically designed for the installation of DMX-SP (see table below). The setup is facilitated by using the XL Pro³ software.

The DMX-SP 4000 can only be mounted in a width of 36 modules.

The front plates for XL³ S 4000 cabinets are pre-drilled to secure the IP40 frames.

DMX-SP or DMX-SP-I 2500 mounting		
24 mod.	36 mod.	Device for fixe and draw-out version
3 392 22		For 1 DMX-SP or DMX-SP-I 2500
	3 392 25	For 1 DMX-SP or DMX-SP-I 2500
Metal faceplates for DMX-SP or DMX-SP-I 2500		
24 mod.	36 mod.	Faceplates for fixed version
3 392 33	3 392 35	For 1 DMX-SP or DMX-SP-I 2500
		Faceplates for draw-out version
3 392 43	3 392 45	For 1 DMX-SP or DMX-SP-I 2500
DMX-SP or DMX-SP-I 4000 mounting		
24 mod.	36 mod.	Device for fixe and draw-out version
	3 391 85	Pour 1 DMX-SP ou DMX-SP-I 4000
Metal faceplates for DMX-SP or DMX-SP-I 4000		
24 mod.	36 mod.	Faceplates for fixed version
	3 392 05	Pour 1 DMX-SP ou DMX-SP-I 4000



It is impossible to install two DMX-SP side by side on the 24 and 36 module plates.

Enclosure other than XL³ S

It is also possible to install the DMX-SP in 'manufacturer' or locally made cabinets. In this case, it is the responsibility of the panel builder to adapt accessories for the proper implementation of the DMX-SP, taking into account the significant weight of these products.

For cabinets other than XL³ S, it is necessary to respect the installation position of the DMX-SP in depth relative to its front panel. Ensure that the space between the DMX-SP and the front panel is sufficient, and that the front face of the DMX-SP slightly protrudes to allow the installation of the IP40 frame (see the drilling plans for the front panels on page 100 according to the type of device).



The metal structure of the DMX-SP 2500 must be connected to the ground of the enclosure. The mounting points should not be considered as connection points.

- Cutting and drilling of the XL³ S 4000 24 modules faceplate for the fixed version of the DMX-SP 2500 (for the 36-module faceplate, use the same position according to the center for cutting and drilling).

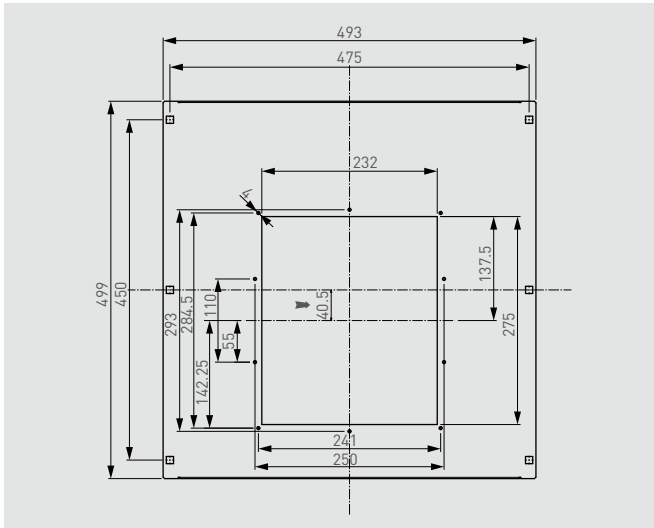

- Cutting and drilling of the XL³ S 4000 24 modules faceplate for the draw-out version of the DMX-SP 2500

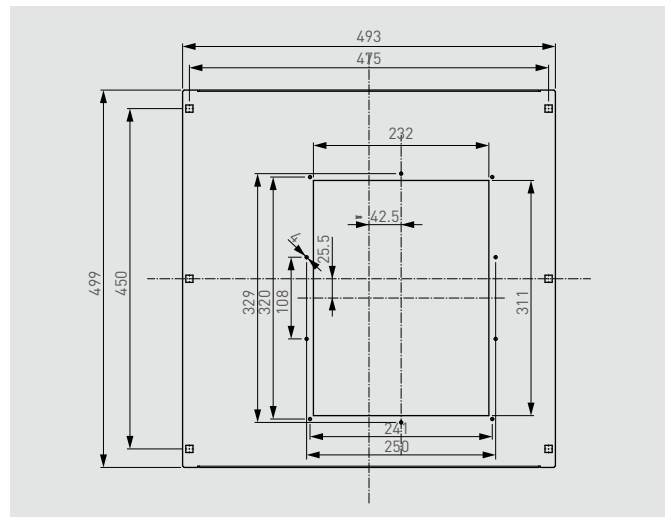

- Cutting and drilling of the XL³ S 4000 36 modules faceplate for the draw-out version of the DMX-SP 2500

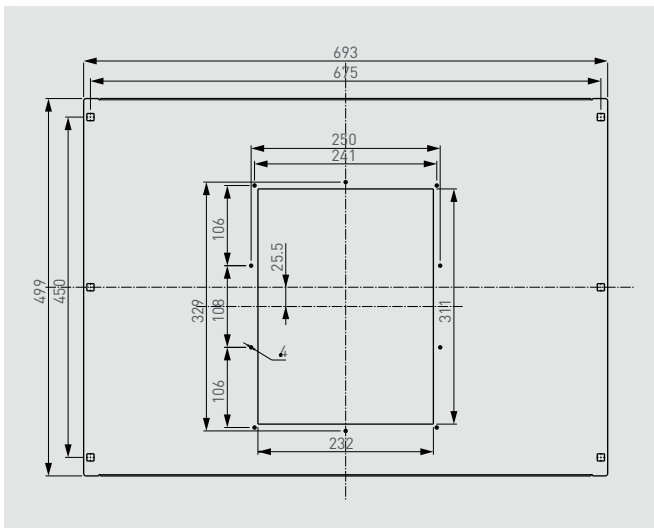

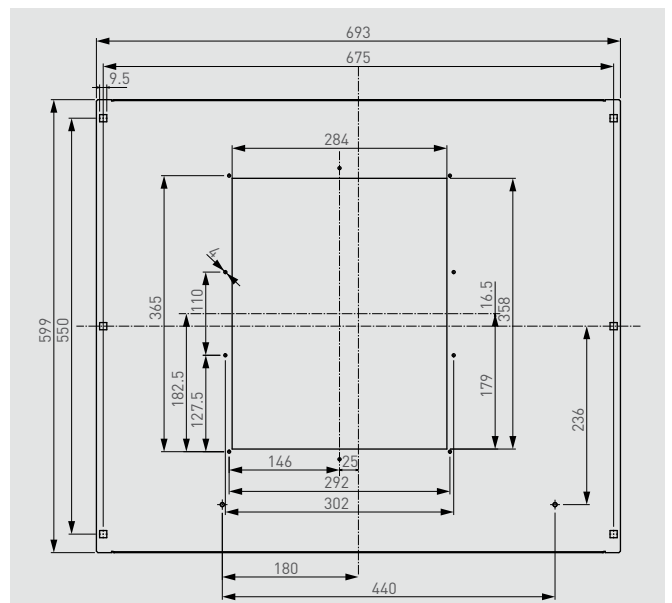

- Cutting and drilling of the XL³ S 4000 36 modules faceplate for the fixed or draw-out version of the DMX-SP 2500



DMX-SP 2500

PROTECTION UNITS

The protection units are inseparable from the circuit breakers. It is not possible to order a circuit breaker alone without its protection unit, and vice-versa. They are factory configured depending on the circuit breaker on which they are installed. Therefore, it is impossible to switch two protection units.

Protection units	Without measure	With measure
MP2.10	 Cat.No 0 283 00	 Cat.No 0 283 01
MP4.10	 Cat.No 0 283 02	 Cat.No 0 283 03

Protection units have integrated current transformers, allowing the self-supply, the setting and the viewing of the off-load circuit breaker datas.

A battery kit (4 CR2 3V lithium batteries) is integrated to the MP4.10 protection unit.



The battery compartment, under the electronic protection unit, is accessible from the front face.

The protection units can as well be supplied with:

- an EMS Cat.No 4 149 45 power supply module (mandatory for protection units with energy meter).
- a USB port (PC, Power Bank, Dongle BLE Cat.No 0 283 10).

 Above 95°C, the protection unit is activated (the temperature measured is that of the protection unit and not of the power contacts).

 For further information on how to operate the LED EMS, please refer to the manual available in the online catalog.

PROTECTION LED STATUS	PROTECTION STATUS
LED off	Inactive
Steady green LED	Active if all the settings are under the levels of pre-alarm required
Steady red LED	Active with overload warning : load at 90% and 105% of Ir set for long delay
Flashing red LED	Active with overload alarm: load exceeds 105% of Ir, defined for long delay protection
Alternating flashing green and red LED	Active with overheat alarm limit ($T > 90\text{ }^{\circ}\text{C}$)

Any other behavior of these LEDs would indicate a malfunction of the protection unit, you should then contact the Professional Relations Service at 0810 48 48 48

SETTING PARAMETERS

Values	Settings	Information
I_r	0,2 to 1 x I_n with 1 A notches	Protection : ON/OFF
t_r	40 ms to 30 s (@6Ir) with 40 ms notches	Thermal memory : ON/OFF
I_{sd}	1,5 to 10 x I_r with 1 A notches	Protection : ON/OFF
t_{sd}	40 ms to 1 s with 40 ms ($t = k$ et $I^2t = k$) notches	-
I_g	0,2 to 1 x I_n with 1 A notches	Protection : ON/OFF
t_g	80 ms to 1 s with 40 ms ($t = k$ et $I^2t = k$) notches	-
I_i	2 to 15 x I_n or I_{cw} with 1 A notches	Protection : ON/OFF
Neutre	Off - 50 % - 100 % - 200 %	-
I_f	fixed (not adjustable)	-

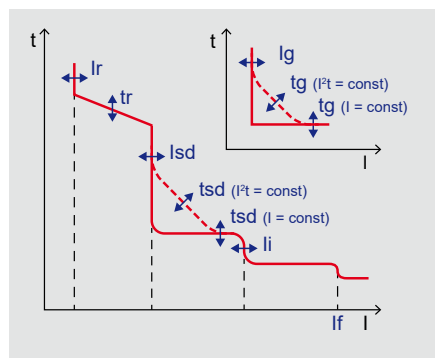

PROTECTION UNIT MP2.10 WITH LED SCREEN

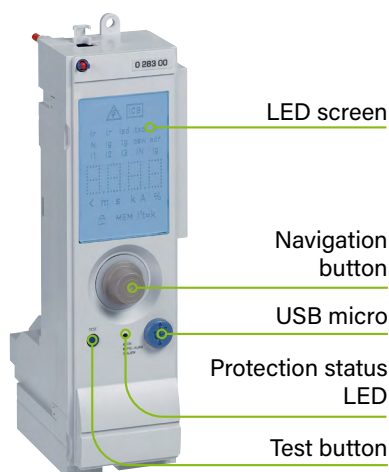

The front face of the protection unit MP2.10 is identical for the 2 references. Once the protection unit activated, the LED screen is visible.

The navigation to view the protection parameters and the setting is operated by turning the navigation button.

The modification of the secondary pages parameters are operated by pushing and turning the button. The confirmation is validated by a new push and insertion of the 5 numbers password (by default «99999», 4 visible numbers).

i For further information, please refer to the manual available in the online catalog.

+ The protection unit MP2.10 is particularly adapted to extreme conditions:

- temperatures between - 50 °C and + 70 °C, tropical climates and saline environments.

PROTECTION UNIT MP4.10 WITH LCD SCREEN

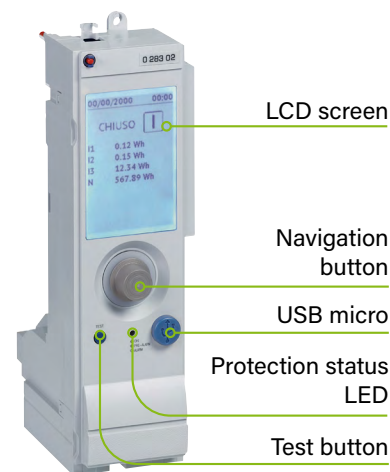

The front face of the protection unit MP4.10 is identical for the 2 references. When powered by batteries only, it is necessary to press the navigation button to turn it on. In other cases, the protection unit automatically turns on.

The navigation through the menu pages is done by turning the button.

The access to the main menu and submenu is possible by pushing the button, the modification of the parameters by pushing and turning the button, and the confirmation of the modifications by pushing again.

i For further information, please refer to the manual available in the online catalog.

+ The protection unit MP4.10 allows an intuitive use thanks to its LCD screen.

Equipped with batteries, the parameters display and the data saving is possible in case of power outage or if the circuit breaker is open or disconnected.

DMX-SP 4000

PROTECTION UNITS

The protection units are inseparable from the circuit breakers. It is not possible to order a circuit breaker alone without its protection unit, and vice-versa. They are factory configured depending on the circuit breaker on which they are installed. Therefore, it is impossible to switch two protection units.

Protection units	Without measure	With measure
MP2.10	 Cat.No 0 283 04	 Cat.No 0 283 05
MP4.10	 Cat.No 0 283 06	 Cat.No 0 283 07

Protection units have integrated current transformers, allowing the self-supply, the setting and the viewing of the off-load circuit breaker datas.

A battery kit (4 CR2 3V lithium batteries) is integrated to the MP4.10 protection unit.



The battery compartment, under the electronic protection unit, is accessible from the front face.

The protection units can as well be supplied with:

- an EMS Cat.No 4 149 45 power supply module (mandatory for protection units with energy meter).
- a USB port (PC, Power Bank, Dongle BLE Cat.No 0 283 10)

PROTECTION LED STATUS	PROTECTION STATUS
LED off	Inactive
Steady green LED	Active if all the settings are under the levels of pre-alarm required
Steady red LED	Active with overload warning : load at 90% and 105% of I_r set for long delay
Flashing red LED	Active with overload alarm: load exceeds 105% of I_r , defined for long delay protection
Alternating flashing green and red LED	Active with overheat alarm limit ($T > 90^\circ\text{C}$)

Any other behavior of these LEDs would indicate a malfunction of the protection unit, you should then contact the Professional Relations Service at 0810 48 48 48

 Above 95°C , the protection unit is activated (the temperature measured is that of the protection unit and not of the power contacts).

 For further information on how to operate the LED EMS, please refer to the manual available in the online catalog.

SETTING PARAMETERS

Values	Settings	Information
I_r	0,2 to 1 x I_n with 1 A notches	Protection : ON/OFF
t_r	40 ms to 30 s (@6Ir) with 40 ms notches	Thermal memory: ON/OFF
I_{sd}	1,5 to 10 x I_r with 1 A notches	Protection : ON/OFF
t_{sd}	40 ms to 1 s a with 40 ms ($t = k$ et $I^2t = k$) notches	
I_g	0,2 to 1 x I_n with 1 A notches	Protection : ON/OFF
t_g	80 ms to 1 s with 40 ms ($t = k$ et $I^2t = k$) notches	
I_i	2 to 15 x I_n or I_{cw} with 1 A notches	Protection : ON/OFF
Neutre	Off - 50 % - 100 % - 200 %	
I_f	fixed (not ajustable)	

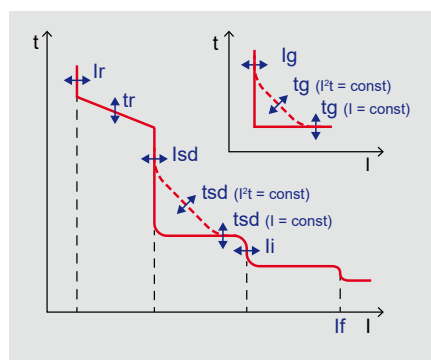

PROTECTION UNIT MP2.10 WITH LED SCREEN

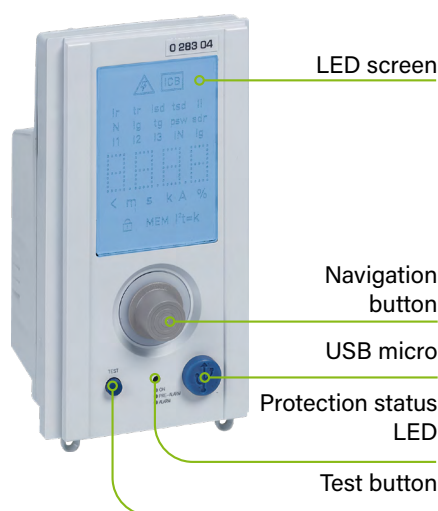

The front face of the protection unit MP2.10 is identical for the 2 references. Once the protection unit activated, the LED screen is visible.

The navigation to view the protection parameters and the setting is operated by turning the navigation button.

The modification of the secondary pages parameters are operated by pushing and turning the button. The confirmation is validated by a new push and insertion of the 5 numbers password (by default «99999», 4 visible numbers).



For further information, please refer to the manual available in the online catalog.



The protection unit MP2.10 is particularly adapted to extreme conditions:

- temperatures between - 50 °C and + 70 °C, tropical climates and saline environments.

PROTECTION UNIT MP4.10 WITH LCD SCREEN



The front face of the protection unit MP4.10 is identical for the 2 references. When powered by batteries only, it is necessary to press the navigation button to turn it on. In other cases, the protection unit automatically turns on.

The navigation through the menu pages is done by turning the button.

The access to the main menu and submenu is possible by pushing the button, the modification of the parameters by pushing and turning the button, and the confirmation of the modifications by pushing again.



For further information, please refer to the manual available in the online catalog.



The protection unit MP4.10 allows an intuitive use thanks to its LCD screen.

Equipped with batteries, the parameters display and the data saving is possible in case of power outage or if the circuit breaker is open or disconnected.

PCS SOFTWARE AND APPLICATION

The protection units can be managed:

- directly on the product (with the rotary selector)
- on a laptop pre-equipped with the software Power Control Station or on a tablet or a smartphone via the project application EnerUp+ with a Bluetooth dongle Cat.No 0 283 10.

The software Power Control Station for laptop or the application EnerUp + Project for smartphone/tablet can be used to exchange datas with the protection unit of the DMX-SP.

The software or the application can be used to:

- monitor the circuit breaker status;
- display information (device and firmware versions, alarms, measures, settings, defects historic, parameters);
- set up the different protections(1)
- update the protection unit firmware(2)
- generate reports based on the datas stocked and read by the protection unit(1);
- operate diagnostic test;
- download the datas related to your profile and to your installation (only with application EnerUp+Project) on the Cloud.

CONFIGURATION ON A LAPTOP (WITH THE SOFTWARE POWER CONTROL STATION):

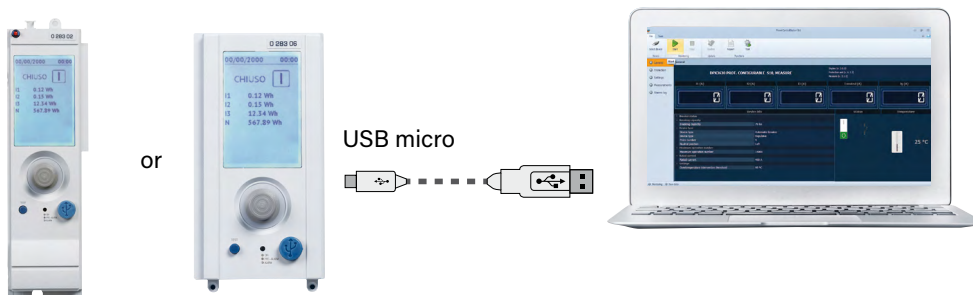

Example of startup screen

This menu displays the values of I1, I2, I3, IN and Ig, the type and state of the circuit breaker, the breaking capacity, the number of poles, the neutral position, the temperature and overhear intervention limit.

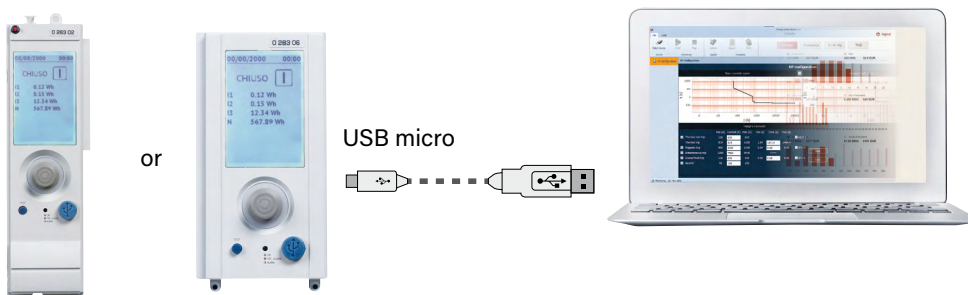

Example of configuration menu

This menu allows the setting of different parameters of the circuit breaker depending on the trigger curves (time/ current and ground default).

(1) Only with the software Power Control Station (version 5.0 minimum)

(2) Only done by the technical assistance Legrand via the software Power Control Station

MANAGEMENT ON A SMARTPHONE/TABLET (APPLICATION ENERUP + PROJECT AVAILABLE ON THE APPLE STORE AND GOOGLE PLAY):



or

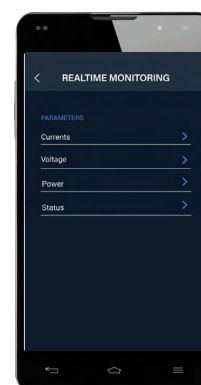
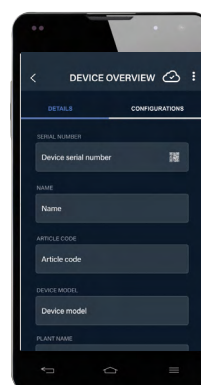

Any design within the MP2.10/MP4.10 range.

BLE S10 dongle
Cat.No 0 283 10 for
MP2.10/MP4.10

Start Menu
The Start Menu provides access to various options such as: overview of connected devices, real-time monitoring, device testing, etc.

Device presentation menu
This menu displays essential information related to the circuit breaker, such as: name, serial number, location, status, settings.

Real time monitoring menu
This menu displays the values for current, voltage, power, and the status of the circuit breaker.

DMX-SP 2500

FIRST COMMISSIONING

Before proceeding with the first mechanical tests and the first powering up of the DMX-SP, for the safety of people and equipment, it is necessary to make sure that the rules and the recommended installation conditions are respected, and that only trained and authorized persons intervene. These persons must also ensure that there are no errors due to negligence and that there are no foreign objects inside the enclosure according to the applicable standards.

There are two types of commissioning checks:

- Power-off checks
- Power-on checks

POWER-OFF CHECKS

- Check the physical integrity of the device. If a part is missing or damaged, it must be replaced. For a draw-out device, check that it is possible to draw-out and re-insert the product without difficulty, with particular care for the inserting terminals of the electrical auxiliaries.
- Make sure that there are no metal parts, tools or work waste near the device.
- Check that the electrical accessories (coils, motors and protection unit) installed correspond to the electrical diagram of the assembly and to the instructions for the products installed.
- Check that the terminal tightening torque is respected:

▪ Draw-out DMX³

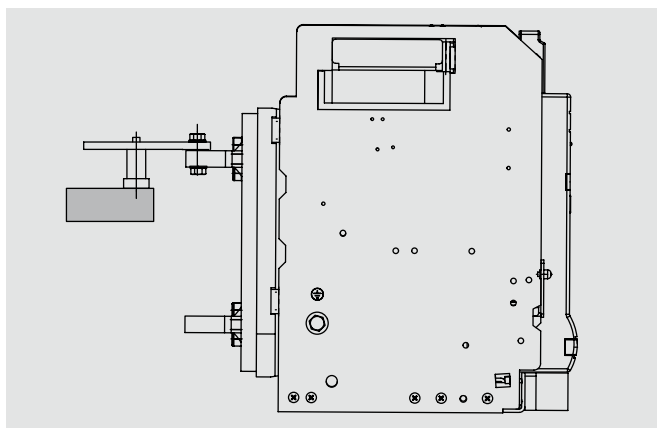

▪ Fixed DMX³

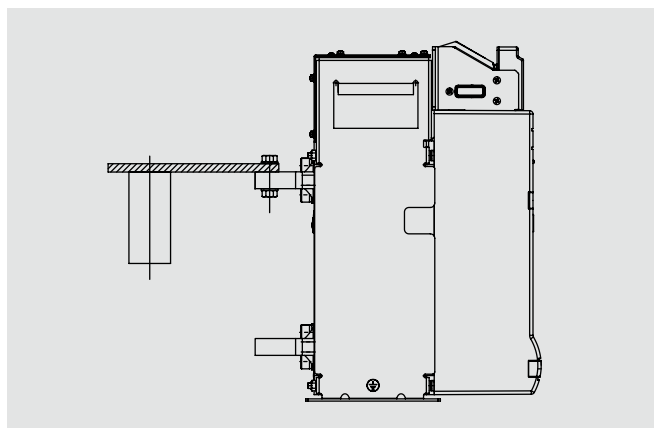

Ø rated : 10 mm (screw M10)

Ø hole : 11 mm

Tightening torque with flat or slit washer: 37,5 Nm

Tightening torque with contact washer: 50 Nm

- For circuit breakers, check the correct operation of the protection unit:
 - Power up the protection unit via an external auxiliary power supply (Cat.No 0 281 72) or a protected direct power supply (See paragraph 9 of the electrical accessories pages 27 and 28).
 - Set the Reset selector on « MAN » position (vertical position, power off) then set the protection unit.
 - Close the circuit breaker and press the test button «T» on the protection unit for at least two seconds.
 - Ensure that all the indicators light up for about 1 second (the “ON” indicator in green and the other indicators in red), and that the Reset selector pops out of its housing.
 - The circuit breaker should trip, and the indicators should turn off.
 - Remember to clear the fault by pressing the Reset selector.

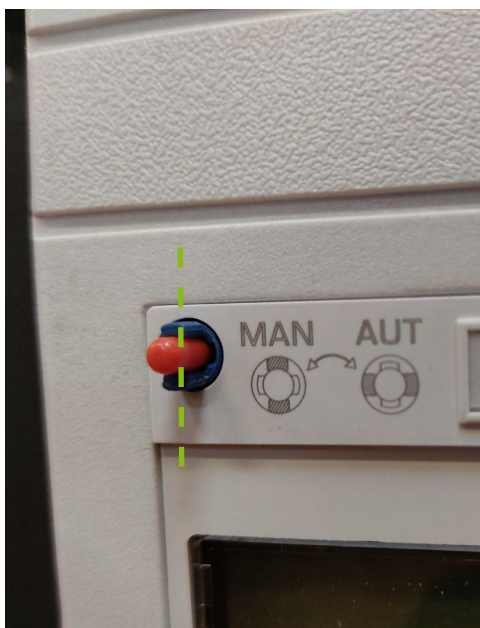

- Make two opening/closing cycles of the DMX-SP, always with the power off, specifically checking the indications on the front of the DMX-SP.

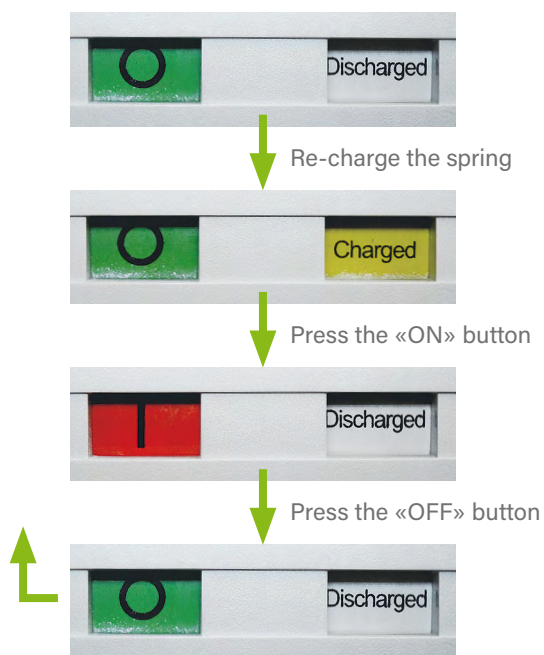

- When using DMX-SP as a transfer switch, it is necessary to check that the operating logic (truth table) complies with the requirements of the interlocking scheme.
- If locking accessories are installed on the DMX-SP (open position, drawn-out position, etc ...), it must be ensured that the function of each is assured.

POWER-ON CHECKS

- Dielectric test**

Before testing under rated current, it is necessary to perform the dielectric test. This standard test must be carried out under certain conditions in order not to damage the DMX-SP protection unit. First of all, isolate all the electronic components of the line to be tested and then disconnect the direct or external power supply. It is recommended to take all the necessary safety measures (sealing, lockout, blocking, marking, etc.) during the test operations in order to avoid possible material and/or physical accidents..

DMX-SP 2500 RESET BUTTON

The circuit breaker can be closed locally or remotely after ensuring that the system and device conditions comply with safety procedures.

- « MAN » position (manual)**

The DMX-SP is delivered with the button in this position. When the product is tripped by the protection unit, it is necessary to press the red RESET button before the closing operation can be carried out.

« MAN » position (blue selector in vertical position) and red RESET button pushed in:



i To change from the « MAN » position to the « AU » position, it is necessary to perform the following operations:

1. Press the red RESET button until the end of the stroke.
2. Keep it pressed and turn the blue selector 90° to the right to place it in the «AUT» position.

• **AUT» position (automatic)**

This position is usually used in supervision systems. Unlike the « MAN » position, it is possible to close the circuit breaker after a trip caused by the protection unit (the RESET button remains pushed in). Before performing this operation, it is necessary to have analyzed (and corrected) the fault that caused the product opening.

Position « AUT » (blue selector switch in horizontal position) and red RESET button pushed in :

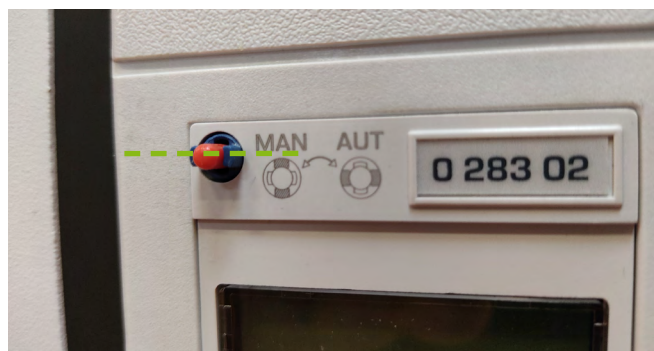

DMX-SP 4000

FIRST COMMISSIONING

Before proceeding with the first mechanical tests and the first powering up of the DMX-SP, for the safety of people and equipment, it is necessary to make sure that the rules and the recommended installation conditions are respected, and that only trained and authorized persons intervene.



The default password is "99999"

POWER-OFF CHECKS

- Check the physical integrity of the device. If a part is missing or damaged, it must be replaced.
- For a draw-out device, check that it is possible to draw-out and re-insert the product without difficulty, with particular care for the inserting terminals of the electrical auxiliaries.
- Check that the electrical accessories (coils, motors and protection unit) installed correspond to the electrical diagram of the assembly and to the instructions for the products installed.

- For circuit breakers, check the correct operation of the protection unit. It is necessary to install the batteries in their slots (for the MP4.10), then proceed to different settings of the protection unit.
- Check the battery charge status (for the MP4.10).
- Turn the “RESET” button of the DMX-SP to the “MAN” position, then power off and close the circuit breaker. Press the test button on the protection unit for at least one second. Confirm the choice by pressing the navigation button for the MP2.10 or by validating on the next screen for the MP4.10.
- The circuit breaker should open, the “ON” indicator turns orange, and the others turn red.
- The “RESET” button should be released from its position.



- Perform two open-close cycles of the DMX-SP, always with the power off, while specifically checking the indications on the front panel of the DMX-SP.
- If using the DMX-SP as a source inverter, it is necessary to ensure that the truth table is respected.
- If there are locking accessories installed on the DMX-SP, you must ensure that each one's function is maintained.

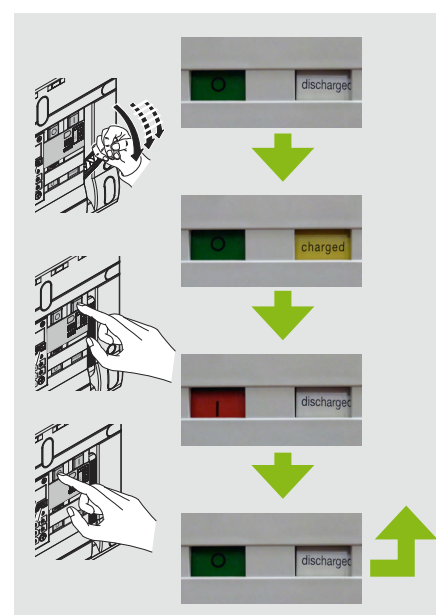

DMX-SP 2500

MAINTENANCE

! We strongly recommend keeping a maintenance log for each product, indicating all verification and maintenance operations performed. The use of a mechanical operation counter is suggested to facilitate the planning and scheduling of periodic maintenance.

! Before working on a DMX-SP or DMX-SP-I, ensure that it is powered off (both power and auxiliary terminals). Only an authorized, trained, and qualified person may intervene, securing and marking the area if necessary.

For a fixed product, it is preferable to cut off its power supply upstream and downstream; otherwise, ensure that the live parts are inaccessible to the technician performing the intervention.

For a draw-out product, it must be locked in the “drawn-out” position.

The spring must be discharged for both types of products.

PREVENTIVE MAINTENANCE

DMX-SP are given for a number of cycles⁽¹⁾. That endurance can be increased if the DMX-SP is subject to regular preventive maintenance.

It is important to do the maintenance in order to :

- ensure the electrical and mechanical performance of the product;
- identify worn or damaged parts or accessories;
- prevent breakdowns.

One maintenance and one periodic checking are recommended on the following parts:

- the mechanism ;
- the mechanical interlocking ;
- the lockings ;
- the loading spring ;
- the arc chambers and arc chutes ;
- the main power contacts ;
- the draw-out base ;
- the terminal block for the connection of electrical auxiliaries ;
- the electrical auxiliaries ;
- the mechanical accessories ;
- the electrical accessories ;
- the protection unit

⁽¹⁾ See next page

i For each demand, you will be asked the series numbers and the manufacturing dates of the DMX-SP and its components.

The manufacturing date is coded «year W week» (example: 19W31, 31st week of 2019).



Every time the product is used/installed in different conditions according to IEC standards, it is recommended to plan and schedule a periodic maintenance to:

- Check the product quality.
- Identify damaged pieces and/or accessories.
- Organize preventive actions to avoid emergencies.

There are two types of maintenance (level 1 and level 2). The following table details the level 1 maintenance actions, and the recommended frequency. They must be operated by trained, qualified technician, knowing the security standards requirements for the distribution systems circuit breakers.

For level 2 actions (every 4 years) please contact your Legrand interlocutor.

Level 1			
Operations	Periodicity ⁽¹⁾	Number of cycles ⁽¹⁾	
		At rated intensity	Power off
1 - Mechanism			
Lubrication and operation	Annual	3000	5000
Joints checking	Annual	3000	5000
2 - Arc chambers			
Annual	Annual	3000	5000
3 - Main contacts			
Visual	Annual	3000	5000
4 - Draw-out system			
Proper operation checking	Annual	3000	5000
Isolation shutter	Every 2 years	3000	5000
Main front/rear contacts of the base	Every 2 years	3000	5000
Terminal block contacts	Every 2 years	3000	5000
Lubrication of the draw-out chassis	Every 2 years	3000	5000
Verification of the operation of the drawn-out mechanism	Every 2 years	3000	5000
5 - Connexion terminal blocks			
Annual	Annual	3000	5000
6 - Auxiliaries			
Visual verifications	Annual	3000	5000
Functionnal test	Every 2 years	3000	5000
7 - Coils and trip units			
Functionnal test	Annual	3000	5000
Loading motor lubrication	Every 2 years	3000	5000
8 - Mechanical accessories			
Locking in «open» position	Annual	-	-
Locking in «drawn-out» position	Annual	-	-
9 - Interlocking mechanism			
Every 2 years	Every 2 years	-	-
10 - Protection unit			
Annual	Annual	-	-

(1) Under normal operating conditions. For more details, please refer to the maintenance guide.



DMX-SP 4000

MAINTENANCE



Before working on a DMX-SP or DMX-SP-I, ensure that it is powered off at both upstream and downstream terminals.

Only an authorized, trained, and qualified person may intervene, securing and marking the area if necessary.

For a fixed product, it is preferable to cut off its power supply upstream and downstream; otherwise, ensure that the live parts are inaccessible to the technician performing the intervention.

For a drawn-out product, it must be locked in the "drawn-out" position.

PREVENTIVE MAINTENANCE

DMX-SP are given for a number of cycles⁽¹⁾. That endurance can be increased if the DMX-SP is subject to regular preventive maintenance.

It is important to do the maintenance in order to :

- ensure the electrical and mechanical performance of the product;
- identify worn or damaged parts or accessories;
- prevent breakdowns

⁽¹⁾ For more details about the frequency and the content of the maintenance procedure, please refer to the maintenance guide available on the online catalog.



For more information about the maintenance and the retrofitting of DMX-SP, please contact your Legrand interlocutor.

One maintenance and one periodic checking are recommended on the following parts:

- the mechanism;
- the mechanical interlocking;
- the lockings;
- the spring;
- the arc chambers and arc chutes;
- the main power contacts;
- the draw-out base;
- the terminal block for the connection of electrical auxiliaries;
- the electrical auxiliaries;
- the mechanical accessories;
- the electrical accessories;
- the protection unit.



For each demand, you will be asked the series numbers and the manufacturing dates of the DMX-SP and its components.

The manufacturing date is coded «year W week» (example: 23W10, 10th week of 2023).



On the right side of the DMX-SP, the end of the serial number is engraved on the metal structure and is fully displayed, along with the manufacturing date on a sticker.









On all the accessories, the manufacturing date is indicated on a small sticker, and on the packaging label.

SPARE PARTS & ACCESSORIES

Spare parts for DMX-SP 2500/4000 are meant to be used and mounted directly by trained and qualified persons. Every spare parts are delivered with a notice that describes the mounting and the reassembly of the faulty part.





PIÈCES DÉTACHÉES POUR LES DMX-SP 2500





CAT.NOS	DESCRIPTION	CONTENT	INFORMATION	NUMBER OF POLES
9 815 00	Door joint	<ul style="list-style-type: none"> - Door joint - Door frame - Mounting screws - Notice 	 Kit for 1 fixed DMX-SP 2500 or 1 fixed DMX-SP-I 2500	3P and 4P
9 815 01	Door joint	<ul style="list-style-type: none"> - Door joint - Door frame - Mounting screws - Notice 	 Kit for «draw-out» 1 DMX-SP 2500 or 1 «draw-out» DMX-SP-I 2500	3P and 4P
4 210 95	Sealing kit	<ul style="list-style-type: none"> - Sealing - Sealing thread - Base + cap (only for DPX/DPX-IS) - Base + cap (only for DPX³) - Sealing accessory for terminal cover (only for DPX³) 	 x 4	3P and 4P
9 815 20	Arc chamber	<ul style="list-style-type: none"> - Arc chamber - Mounting screws - Notice 	 Kit for 1 pole	3P and 4P
9 815 07	Terminal blocks support	<ul style="list-style-type: none"> - Terminal blocks support x 1 - Mounting screw kit - Notice 	 Components for 1 DMX-SP 2500	3P and 4P
9 815 10	Spring charging lever	<ul style="list-style-type: none"> - Circuit breaker lever (black) - Switch lever (grey) - Spring charging mechanism - Benzing ring - Seiger ring - Spring - Notice 	 Kit for 1 DMX-SP 2500 or 1 DMX-SP-I 2500	3P and 4P

CAT.NOS	DESCRIPTION	CONTENT		INFORMATION	NUMBER OF POLES
9 815 11	Extraction crank.	- Crank x1 - Notice		1 crank for a draw-out DMX-SP 2500	3P and 4P
9 815 31	Connection clamps	- Connection clamp x1 - Screw and washer - Notice		Kit for 1 pole of a DMX-SP 2500 draw-out base	3P and 4P
0 290 33	Isolation shutter	- Movable shutter - Fixed shutter - Springs - Screws - Notice		Kit for 1 draw-out DMX-SP 2500	3P
0 290 34	Isolation shutter	- Movable shutter - Fixed shutter - Springs - Screws - Notice		Kit for 1 draw-out DMX-SP 2500	4P
9 815 26	Secondary front panel	- Secondary front panel - Screw kit - Notice		Required components for 1 DMX-SP 2500	3P
9 815 27	Secondary front panel	- Secondary front panel - Screw kit - Notice		Required components for 1 DMX-SP 2500	4P
9 815 16	Front cover blanking kit for draw-out base	- Front cover - Locking cover - Padlock closure - Front shutter - Springs - Screws + washers		Kit for 1 DMX-SP 2500 draw-out base	3P and 4P
0 290 52	Fixed terminal block for connection.	- Fixed terminal block for connection x 10 - Notice		Required kit for 10 electrical auxiliaries	3P and 4P
Contact Legrand	Mechanical grease	- Mechanical grease		0,5 Kg pot: allows the greasing of 10 DMX-SP 2500	3P and 4P

LES PIÈCES DÉTACHÉES

PIÈCES DÉTACHÉES POUR LES DMX-SP 4000

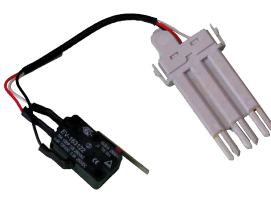
CAT.NOS	DESCRIPTION	CONTENT	INFORMATION	NUMBER OF POLES	
0 288 22	Door frame	<ul style="list-style-type: none"> - Joint x 1 - Frame x 1 - Screw x 10 - Notice 		Kit for 1 DMX-SP 4000 or 1 DMX-SP-I 4000 fixed or draw-out version	3P and 4P
4 210 95	Sealing kit	<ul style="list-style-type: none"> - Sealing - Sealing thread - Base + cap (only for DPX/DPX-IS) - Base + cap (only for DPX³) - Sealing accessory for terminal cover (only for DPX³) 		x 4	3P and 4P
0 290 12	Terminal blocks support	<ul style="list-style-type: none"> - Terminal blocks support x 1 - Mounting screw kit - Notice 		Required components for 1 DMX-SP 4000	3P and 4P
0 290 17	Secondary front panel	<ul style="list-style-type: none"> - Secondary front panel protection (x 2): - Screws : <ul style="list-style-type: none"> → 3P : x 4 → 4P : x 6 - Notice 		Required kit for 1 DMX-SP 4000	3P
0 290 55					4P
0 290 52	Fixed terminal block for connection.	<ul style="list-style-type: none"> - Fixed terminal block for connection x 10 - Notice 		Required kit for 10 electrical auxiliaries	3P and 4P

CAT.NOS	DESCRIPTION	CONTENT	INFORMATION	NUMBER OF POLES
0 290 08	Spring charging lever	<ul style="list-style-type: none"> - Lever for circuit breaker (black) - Lever for switch (grey) - Spring charging mechanism - Benzing ring - Seiger ring - Springs - Notice 		Required kit for 1 DMX-SP 4000 or 1 DMX-SP-I 4000 3P and 4P
9 815 18	Extraction crank.	<ul style="list-style-type: none"> - Crank x 2 - Notice 		Required kit for 2 draw-out DMX-SP 4000 3P and 4P
0 290 69	Contact and connector replacement kit.	<ul style="list-style-type: none"> - Electrical auxiliaries reparation kit - Notice 		<ul style="list-style-type: none"> - Auxiliary contact and connector x 2 - Motor connector x 1 - Replacement connector x 3 3P and 4P
0 290 40	Tool for inspecting connection clamps.	<ul style="list-style-type: none"> - Left tool - Right tool - Notice 		Tool required for the manual opening of isolation shutters 3P and 4P
Contact Legrand	Mechanical Grease	<ul style="list-style-type: none"> - Mechanical Grease 		0,5 Kg pot: allows the greasing of 10 DMX-SP 4000 3P and 4P



FOLLOW US ALSO ON

- @ legrand.com
-  youtube.com/user/legrand
-  facebook.com/Legrand
-  twitter.com/Legrand
-  pinterest.com/legrandgroup
-  instagram.com/legrandnews



Head office
and International Department
87045 Limoges Cedex - France
Tel: + 33 (0) 5 55 06 87 87
Fax: + 33 (0) 5 55 06 74 55