

# Incara™ Flip up

## technische kenmerken

### Afmetingen (mm)

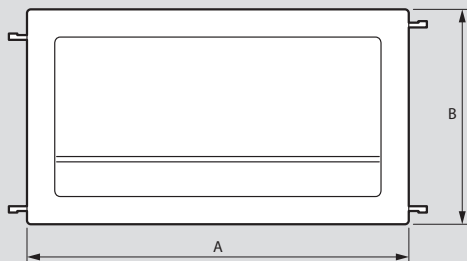
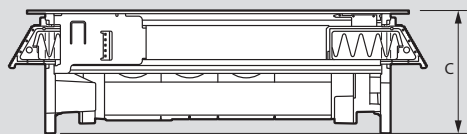

Referenties	A	B	C
654850/51	303	170,5	97,5
654852/53	303		

### Installatie op een werkblad

Boormaten en maximale snijradius in de hoeken

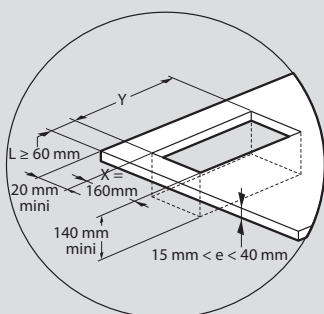

Referenties	Y ± 1 mm
654850/51/54/55 654958/59/60/61/62/63	286
654752/53/56/57 654964/65/66/67/68/69	376

**Opmerking:** Andere boormaten: zie het technische gegevensblad dat online beschikbaar is

### Gebruik

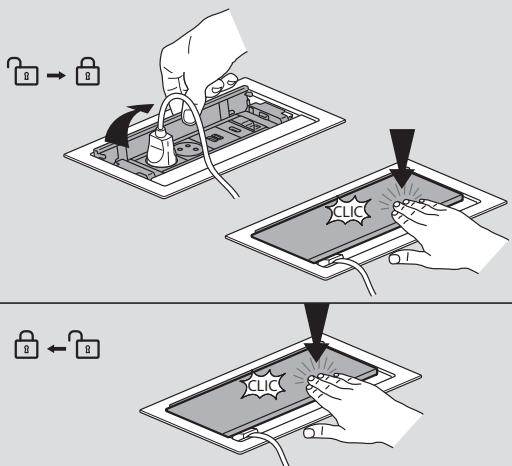

### Inwerking en bevestiging

