

# Incara™ Pop up

## caractéristiques techniques

### ■ Dimensions

#### 4 modules

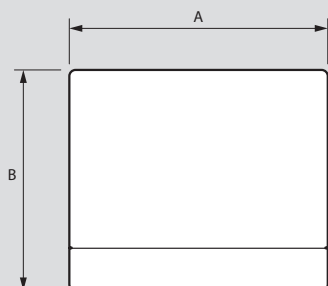

Références	A	B
654800/01/02/03/16/17/27	146	125

#### 8 modules

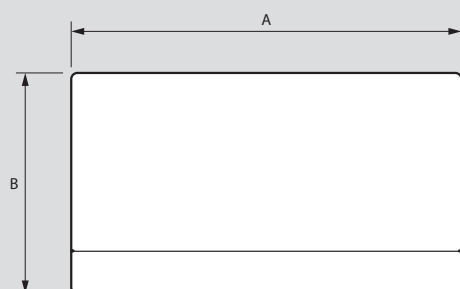

Références	A	B
654808/09/10/11/20	236	125

#### Ouvert sur la table

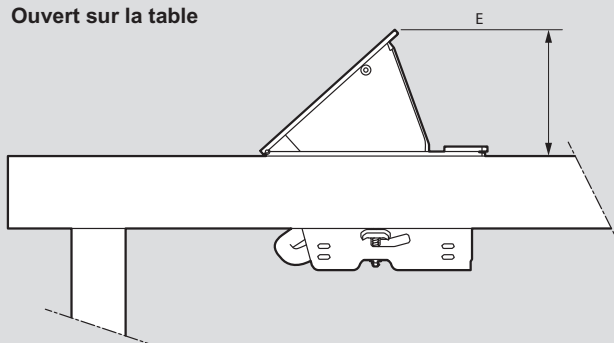

Références	E
654800/01/02/03/08/09/10/11/16/17/20/27	70

#### Fermé sur la table

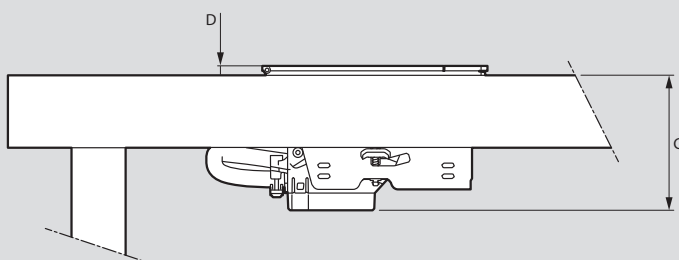

Références	C	D
654800/01/02/03/08/09/10/11/16/17/20/27	75	5.2

### ■ Cotes de perçage

#### Découpe en usinage angles vifs

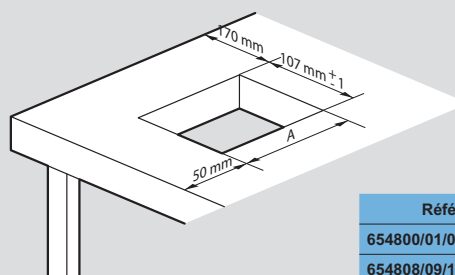

Références	A
654800/01/02/03/16/17/27	129 mm ± 1
654808/09/10/11/20	219 mm ± 1



Nota : Autres découpes : voir la fiche technique disponible en ligne

### ■ Cotes d'encombrement sous le plan de travail

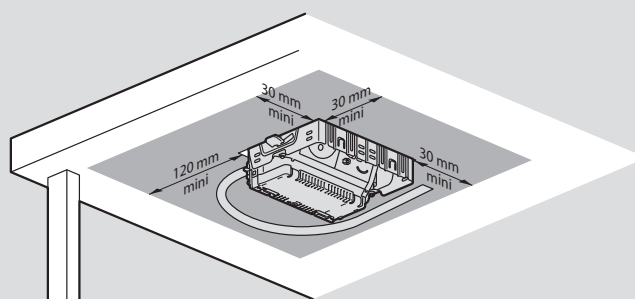

### ■ Introduction

