

ID	Description	Date	By	Appr.

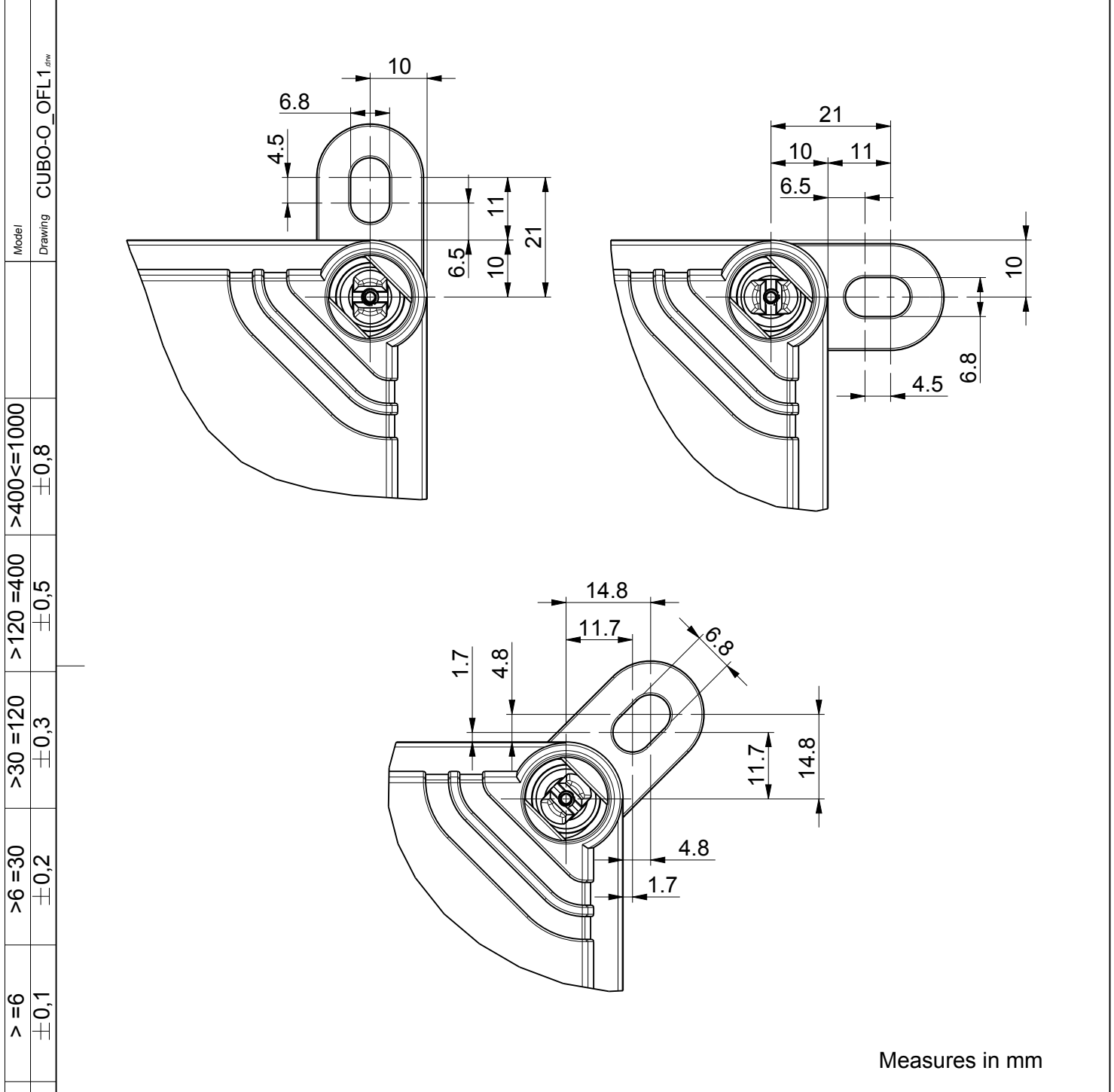

Measures in mm

Tolerance ISO 2768-m	2	Code	Enclosure	1	2259
	1	OFL1/4	Fastening lug set, (PMR1825 + PLP80)	3	6
	Part	Code	Description	Pcs	Weight [g]/pcs
	Supplier:	Tool No:	Volume	Weight [g]	0
Material:			Ensto Mat:		
 Ensto Finland Oy Ensto Electrification				Replaces: Replaced: Drw No: Ref: Code:	
Scale 1:1		Date 4.11.2016			
A4		By KA			
Sheet No: 1 (1)		Checked			
		Ctrl		Fastening lug OFL1 on Cubo O enclosure	